

Informix Product Family
Informix
Version 11.70

IBM Informix Administrator's Reference



Informix Product Family
Informix
Version 11.70

IBM Informix Administrator's Reference



Note

Before using this information and the product it supports, read the information in "Notices" on page H-1.

Edition

This edition replaces SC27-3530-03.

This document contains proprietary information of IBM. It is provided under a license agreement and is protected by copyright law. The information contained in this publication does not include any product warranties, and any statements provided in this manual should not be interpreted as such.

When you send information to IBM, you grant IBM a nonexclusive right to use or distribute the information in any way it believes appropriate without incurring any obligation to you.

© Copyright IBM Corporation 1996, 2012.

US Government Users Restricted Rights – Use, duplication or disclosure restricted by GSA ADP Schedule Contract with IBM Corp.

Contents

Introduction	xxiii
About This Publication	xxiii
Types of Users.	xxiii
Software Dependencies	xxiii
Assumptions about your locale	xxiii
Demonstration databases	xxiv
What's New in Administrator's Reference for Informix database server, Version 11.70	xxiv
Example code conventions	xxxiv
Additional documentation	xxxiv
Compliance with industry standards	xxxv
Syntax diagrams	xxxv
How to read a command-line syntax diagram	xxxvi
Keywords and punctuation	xxxvii
Identifiers and names.	xxxvii
How to provide documentation feedback	xxxviii

Part 1. Configuring and monitoring Informix

Chapter 1. Database configuration parameters	1-1
onconfig File Conventions	1-1
Creating the onconfig File	1-2
Displaying the Settings in the onconfig File	1-2
onconfig Portal: Configuration parameters by functional category	1-3
ADMIN_MODE_USERS configuration parameter	1-24
ADMIN_USER_MODE_WITH_DBSA Configuration Parameter	1-25
ALARMPROGRAM configuration parameter	1-26
ALLOW_NEWLINE Configuration Parameter	1-27
ALRM_ALL_EVENTS configuration parameter	1-28
AUTO_AIOVPS Configuration Parameter.	1-28
AUTO_CKPTS configuration parameter	1-29
AUTO_LRU_TUNING configuration parameter.	1-29
AUTO_READAHEAD configuration parameter.	1-30
AUTO_REPREPARE configuration parameter	1-31
AUTO_STAT_MODE configuration parameter	1-32
BATCHEDREAD_INDEX configuration parameter.	1-33
BATCHEDREAD_TABLE configuration parameter.	1-33
BLOCKTIMEOUT configuration parameter	1-34
BTSCANNER Configuration Parameter	1-34
BUFFERPOOL configuration parameter	1-36
CHECKALLDOMAINSFORUSER configuration parameter	1-39
CKPTINTVL configuration parameter	1-40
CLEANERS Configuration Parameter	1-41
CONSOLE configuration parameter.	1-41
CONVERSION_GUARD configuration parameter	1-41
DATASKIP Configuration Parameter	1-42
DBCREATE_PERMISSION Configuration Parameter	1-43
DB_LIBRARY_PATH Configuration Parameter	1-44
DBSERVERALIASES configuration parameter	1-44
DBSERVERNAME configuration parameter	1-46
DBSPACETEMP configuration parameter	1-47
Use Hash Join Overflow and DBSPACETEMP	1-49
DD_HASHMAX configuration parameter.	1-50
DD_HASHSIZE Configuration Parameter.	1-50
DEADLOCK_TIMEOUT configuration parameter	1-50
DEF_TABLE_LOCKMODE configuration parameter	1-51

DEFAULTESCCHAR configuration parameter	1-52
DELAY_APPLY Configuration Parameter	1-53
DIRECT_IO Configuration Parameter (UNIX)	1-53
DIRECTIVES configuration parameter	1-55
DISABLE_B162428_XA_FIX Configuration Parameter	1-55
DRDA_COMMBUFFSIZE Configuration Parameter	1-56
DRAUTO configuration parameter	1-57
DRIDXAUTO Configuration Parameter	1-58
DRINTERVAL configuration parameter	1-58
DRLOSTFOUND Configuration Parameter	1-59
DRTIMEOUT configuration parameter.	1-59
DS_HASHSIZE Configuration Parameter	1-60
DS_MAX_QUERIES configuration parameter	1-61
DS_MAX_SCANS configuration parameter	1-62
DS_NONPDQ_QUERY_MEM configuration parameter	1-63
DS_POOLSIZ Configuration Parameter	1-64
DS_TOTAL_MEMORY configuration parameter.	1-64
Algorithm for DS_TOTAL_MEMORY	1-66
DUMPCNT configuration parameter (UNIX).	1-66
DUMPCORE Configuration Parameter (UNIX)	1-67
DUMPDIR Configuration Parameter	1-67
DUMPGCORE Configuration Parameter (UNIX)	1-67
DUMPSHMEM configuration parameter (UNIX)	1-68
DYNAMIC_LOGS configuration parameter	1-69
EILSEQ_COMPAT_MODE configuration parameter	1-70
ENABLE_SNAPSHOT_COPY configuration parameter	1-71
ENCRYPT_CIPHERS Configuration Parameter	1-71
ENCRYPT_HDR Configuration Parameter	1-73
ENCRYPT_MAC Configuration Parameter	1-73
ENCRYPT_MACFILE configuration parameter	1-74
ENCRYPT_SMX Configuration Parameter	1-75
ENCRYPT_SWITCH configuration parameter	1-76
EXPLAIN_STAT Configuration Parameter	1-76
EXT_DIRECTIVES Configuration Parameter	1-77
EXTSHMADD configuration parameter	1-78
FAILOVER_CALLBACK Configuration Parameter	1-79
FAILOVER_TX_TIMEOUT configuration parameter	1-79
FASTPOLL Configuration Parameter	1-80
FILLFACTOR configuration parameter.	1-81
FULL_DISK_INIT Configuration Parameter	1-81
GSKIT_VERSION configuration parameter	1-82
HA_ALIAS configuration parameter	1-82
HETERO_COMMIT Configuration Parameter	1-83
IFX_EXTEND_ROLE configuration parameter	1-83
IFX_FOLDVIEW configuration parameter.	1-84
LIMITNUMSESSIONS configuration parameter.	1-85
LISTEN_TIMEOUT configuration parameter.	1-86
LOCKS Configuration Parameter	1-86
LOGBUFF configuration parameter.	1-87
LOGFILES configuration parameter.	1-88
LOG_INDEX_BUILDS Configuration Parameter	1-89
LOG_STAGING_DIR configuration parameter	1-90
LOGSIZE configuration parameter	1-90
LOW_MEMORY_MGR configuration parameter	1-91
LOW_MEMORY_RESERVE configuration parameter	1-92
LTXEHWM configuration parameter	1-93
LTXHWM configuration parameter	1-94
MAX_FILL_DATA_PAGES Configuration Parameter	1-95
MAX_INCOMPLETE_CONNECTIONS configuration parameter	1-96
MAX_PDQPRIORITY configuration parameter	1-96
MIRROR Configuration Parameter	1-98

MIRROROFFSET Configuration Parameter	1-98
MIRRORPATH configuration parameter	1-98
MSG_DATE configuration parameter	1-99
MSGPATH configuration parameter	1-100
MULTIPROCESSOR Configuration Parameter	1-100
NET_IO_TIMEOUT_ALARM configuration parameter	1-101
NETTYPE Configuration Parameter	1-101
NS_CACHE configuration parameter	1-104
NUMFDSERVERS configuration parameter	1-106
OFF_RECVRY_THREADS configuration parameter	1-107
ON_RECVRY_THREADS Configuration Parameter	1-107
ONDBSPACEDOWN configuration parameter	1-108
Database Server Behavior When ONDBSPACEDOWN Does Not Apply	1-108
ONLIDX_MAXMEM configuration parameter	1-109
OPCACHEMAX Configuration Parameter (UNIX)	1-109
OPTCOMPIND configuration parameter	1-110
OPT_GOAL Configuration Parameter	1-111
PC_HASHSIZE Configuration Parameter	1-112
PC_POOLSIZE Configuration Parameter	1-112
PHYSBUFF Configuration Parameter	1-113
PHYSFILE Configuration Parameter	1-113
PLOG_OVERFLOW_PATH Configuration Parameter	1-114
PN_STAGEBLOB_THRESHOLD configuration parameter	1-114
PRELOAD_DLL_FILE Configuration Parameter	1-115
QSTATS Configuration Parameter	1-116
RA_PAGES configuration parameter	1-116
REMOTE_SERVER_CFG configuration parameter	1-117
REMOTE_USERS_CFG configuration parameter	1-118
RESIDENT configuration parameter	1-119
RESTARTABLE_RESTORE Configuration Parameter	1-120
RESTORE_POINT_DIR configuration parameter	1-121
ROOTNAME Configuration Parameter	1-122
ROOTOFFSET Configuration Parameter	1-122
ROOTPATH Configuration Parameter	1-122
ROOTSIZE configuration parameter	1-123
RSS_FLOW_CONTROL Configuration Parameter	1-123
RTO_SERVER_RESTART configuration parameter	1-125
S6_USE_REMOTE_SERVER_CFG configuration parameter	1-125
SB_CHECK_FOR_TEMP configuration parameter	1-126
SBSPACENAME configuration parameter	1-127
SBSPACETEMP configuration parameter	1-128
SDS_ENABLE Configuration Parameter	1-129
SDS_LOGCHECK configuration parameter	1-130
SDS_PAGING Configuration Parameter	1-131
SDS_TEMPDBS Configuration Parameter	1-131
SDS_TIMEOUT configuration parameter	1-133
SECURITY_LOCALCONNECTION Configuration Parameter	1-133
SEQ_CACHE_SIZE configuration parameter	1-134
SERVERNUM configuration parameter	1-134
SHMADD configuration parameter	1-135
SHMBASE Configuration Parameter	1-136
SHMNOACCESS Configuration Parameter	1-136
SHMTOTAL configuration parameter	1-137
SHMVIRT_ALLOCSEG configuration parameter	1-138
SHMVIRTSIZE configuration parameter	1-139
SINGLE_CPU_VP configuration parameter	1-141
VPCLASS Values and the SINGLE_CPU_VP Configuration Parameter	1-141
SMX_COMPRESS configuration parameter	1-142
SP_AUTOEXPAND configuration parameter	1-143
SP_THRESHOLD configuration parameter	1-143
SP_WAITTIME configuration parameter	1-144

SQL_LOGICAL_CHAR configuration parameter	1-145
SQLTRACE Configuration Parameter	1-147
SSL_KEYSTORE_LABEL configuration parameter.	1-148
STACKSIZE configuration parameter	1-149
STAGEBLOB Configuration Parameter	1-150
STATCHANGE configuration parameter.	1-150
STMT_CACHE Configuration Parameter	1-151
STMT_CACHE_HITS Configuration Parameter	1-152
STMT_CACHE_NOLIMIT Configuration Parameter	1-152
STMT_CACHE_NUMPOOL Configuration Parameter	1-153
STMT_CACHE_SIZE Configuration Parameter	1-153
STOP_APPLY configuration parameter	1-154
STORAGE_FULL_ALARM Configuration Parameter.	1-155
SYSALARMPROGRAM configuration parameter	1-156
SYSSBSPACENAME configuration parameter	1-157
TBLSPACE_STATS configuration parameter	1-158
TBLTBLFIRST configuration parameter	1-159
TBLTBLNEXT configuration parameter	1-159
TEMPTAB_NOLOG configuration parameter	1-160
TXTIMEOUT configuration parameter	1-161
UNSECURE_ONSTAT Configuration Parameter	1-161
UPDATABLE_SECONDARY Configuration Parameter	1-162
USELASTCOMMITTED configuration parameter	1-162
USEOSTIME Configuration Parameter	1-164
USERMAPPING configuration parameter (UNIX, Linux)	1-165
USTLOW_SAMPLE configuration parameter	1-166
VP_MEMORY_CACHE_KB configuration parameter	1-166
VPCLASS configuration parameter	1-167
WSTATS configuration parameter	1-170

Chapter 2. The sysmaster database 2-1

The sysmaster Database	2-1
The buildsmi Script	2-1
The bldutil.sh Script	2-2
The System-Monitoring Interface	2-2
Understanding the SMI Tables	2-2
Accessing SMI tables	2-3
The System-Monitoring Interface Tables.	2-4
The sysutils Tables.	2-6
sysadinfo	2-7
sysaudit	2-7
syschkio	2-8
syscheckpoint	2-8
syschunks	2-9
sysckptinfo	2-10
syscluster	2-11
syscsm.	2-12
syscsmmsla	2-13
syscsmstab.	2-13
syscompdicts_full.	2-13
sysconfig	2-15
sysdatabases	2-15
sysdbslocale	2-16
sysdbspaces	2-16
sysdri.	2-17
sysdual	2-18
sysenv	2-18
sysenvses	2-18
sysextents	2-18
sysextspaces	2-19
sysfeatures	2-19

syssha_lagtime Table	2-20
syssha_type	2-21
syssha_workload	2-21
sysipl.	2-22
syslocks	2-22
syslogs	2-23
syslogfil table	2-24
sysmgminfo	2-24
sysnetclienttype	2-25
sysnetglobal	2-25
sysnetworkio table	2-26
sysonlinelog	2-26
sysprofile	2-27
sysproxyagents	2-28
sysproxydistributors	2-29
sysproxysessions table	2-29
sysproxytxnops table	2-30
sysproxytxns table	2-30
sysptprof table.	2-31
sysrepevtreg table	2-31
sysrepstats table	2-32
sysrsslog.	2-35
sysscblst	2-35
sysseappinfo	2-35
sysseprof	2-36
syssessions	2-36
sysmx	2-38
sysmxses	2-38
syssexplain table	2-38
sysqltrace	2-39
sysqltrace_info	2-41
sysqltrace_iter	2-41
sysrcrss	2-41
sysrcsds	2-42
systabnames	2-42
systhreads	2-43
systrgrss	2-43
systrgsds	2-44
sysvpprof	2-44
The SMI Tables Map.	2-45
Information from onstat in the SMI Tables	2-46
Chapter 3. The sysadmin Database	3-1
The Scheduler Tables	3-1
The ph_task Table	3-2
The ph_run Table	3-4
The ph_group Table	3-5
The ph_alert Table	3-5
The ph_threshold Table	3-7
Results Tables	3-8
The command_history table.	3-8
The storagepool table	3-9
Chapter 4. Disk Structures and Storage	4-1
Dbospace Structure and Storage.	4-1
Structure of the Root Dbospace	4-1
Reserved Pages	4-2
Structure of a Regular Dbospace	4-2
Structure of the Chunk Free-List Page	4-4
Structure of the Tblspace Tblspace	4-4

Structure of the Database Tblspace	4-7
Structure and Allocation of an Extent	4-7
Structure and Storage of a Dbspace Page	4-12
Structure of Fragmented Tables	4-15
Structure of B-Tree Index Pages	4-16
Structure of R-Tree Index Pages	4-21
Storage of Simple Large Objects	4-21
Structure of a Blobpage	4-21
Structure of a Dbspace Blobpage.	4-22
Simple-Large-Object Storage and the Descriptor	4-22
Blobpage Page Types	4-23
Structure of a Blobpage Blobpage	4-23
Sbspace Structure.	4-24
Structure of the metadata area	4-25
Sbpage Structure	4-26
Multiple Chunk Sbspace	4-26
Time Stamps	4-27
Database and Table Creation: What Happens on Disk.	4-27
Database Creation	4-27
Table Creation	4-28

Chapter 5. Interpreting Logical-Log Records 5-1

About Logical-Log Records	5-1
Transactions That Drop a Table or Index	5-1
Transactions That Are Rolled Back	5-1
Checkpoints with Active Transactions	5-2
Distributed Transactions	5-2
Logical-Log Record Structure	5-2
Logical-Log Record Header	5-2
Logical-Log Record Types and Additional Columns.	5-3
Log Record Types for Smart Large Objects	5-14

Part 2. Administrative Utilities

Chapter 6. Overview of Utilities 6-1

Obtaining Utility Version Information	6-1
IBM Informix Server Administrator	6-2

Chapter 7. The finderr utility 7-1

Chapter 8. The genoncfg Utility 8-1

Chapter 9. The oncheck Utility 9-1

oncheck Check-and-Repair	9-1
What Does Each Option Do?	9-1
Using the -y Option to Perform Repairs.	9-2
Repairing Indexes in Sbspaces and External Spaces	9-3
Locking and oncheck	9-3
oncheck syntax	9-3
oncheck -cc and -pc: Check system catalog tables.	9-8
oncheck -cd and oncheck -cD commands: Check pages	9-8
oncheck -ce, -pe: Check the chunk-free list	9-10
oncheck -ci and -cI : Check index node links.	9-10
oncheck -cr and -cR: Check reserved pages	9-12
oncheck -cs, -cS, -ps, -pS: Check and display sbspaces	9-13
oncheck -pB: Display blobpage statistics	9-13
oncheck -pd and pD: Display rows in hexadecimal format	9-13
oncheck -pk, -pK, -pl, -pL: Display index information.	9-15
oncheck -pp and -pP: Display the contents of a logical page	9-16

oncheck -pr and pR: Display reserved-page information	9-18
oncheck -pt and -pT: Display tablespaces for a Table or Fragment	9-19
Turn On Locking with -x	9-21
Send Special Arguments to the Access Method with -u	9-22
Return Codes on Exit	9-22
Chapter 10. The onclean Utility	10-1
The onshutdown script	10-2
Chapter 11. The oncmsm utility	11-1
Service Level Agreement Examples	11-12
Failover Configuration Examples	11-16
Proxy Mode and Redirect Mode	11-17
Chapter 12. The ondblog Utility	12-1
ondblog: Change Logging Mode.	12-1
ondblog Syntax	12-1
Chapter 13. The oninit utility	13-1
Return codes for the oninit utility	13-4
Chapter 14. The onlog Utility	14-1
Chapter 15. The onmode utility	15-1
onmode Syntax	15-1
onmode -a: Add a shared-memory segment	15-2
onmode -BC: Allow large chunk mode.	15-3
onmode -c: Force a checkpoint	15-4
onmode -C: Control the B-tree scanner.	15-5
onmode -cache surrogates: Cache the allowed.surrogates file	15-6
onmode -d: Set data-replication types	15-7
Using the -d standard Option.	15-8
Using the -d primary dbservername Option	15-8
Using the -d secondary dbservername option	15-8
onmode -d: Set High Availability server characteristics	15-9
onmode -d command: Replicate an index with data-replication	15-11
onmode -D, -M, -Q, -S: Change decision-support parameters	15-12
onmode -e: Change usage of the SQL statement cache	15-14
onmode -F: Free unused memory segments.	15-14
onmode -I: Control diagnostics collection	15-15
onmode -k, -m, -s, -u, -j: Change database server mode.	15-16
Taking the Database Server to Offline Mode with the -k Option	15-17
Bringing the Database Server Online with the -m Option	15-17
Shutting Down the Database Server Gracefully with the -s Option	15-17
Shutting Down the Database Server Immediately with the -u Option	15-17
Changing the Database Server to Administration Mode with the -j Option	15-18
Changing Database Server Mode with ON-Monitor (UNIX)	15-18
onmode -l: Switch the logical-log file	15-19
onmode -n, -r: Change shared-memory residency.	15-19
onmode -O: Override ONDBSPACEDOWN WAIT mode	15-20
onmode -p: Add or remove virtual processors.	15-20
Adding and Dropping Virtual Processors	15-22
Dropping Virtual Processors Automatically	15-22
Monitoring poll threads with the onstat utility.	15-23
onmode -P: Start, stop, or restart a listen thread dynamically.	15-23
onmode -R: Regenerate .infos File	15-24
onmode -W: Change settings for the SQL statement cache	15-25
SQL statement cache examples	15-25
onmode -wf, -wm: Dynamically change certain configuration parameters.	15-26

onmode -wm: Change LRU tuning status	15-28
onmode -Y: Dynamically change SET EXPLAIN	15-29
onmode -z: Kill a database server session	15-30
onmode -Z: Kill a distributed transaction	15-31

Chapter 16. The ON-Monitor Utility 16-1

Using ON-Monitor (UNIX)	16-1
Navigating ON-Monitor and Using Help	16-1
Executing Shell Commands Within ON-Monitor	16-2
ON-Monitor Screen Options	16-2

Chapter 17. The onparams Utility 17-1

onparams Syntax	17-1
onparams -a -d <i>dbspace</i> : Add a logical-log file	17-2
onparams -d -l <i>lognum</i> : Drop a logical-log file	17-2
onparams -p : Change physical-log parameters	17-3
Backing Up After You Change the Physical-Log Size or Location	17-4
Changing the Size of the Physical Log and Using Non-Default Page Sizes	17-4
onparams -b: Add a new buffer pool	17-4
Examples of onparams Commands	17-6

Chapter 18. The onpassword utility. 18-1

Configuring secure connections using a password file	18-3
--	------

Chapter 19. The ifxclone utility 19-1

Chapter 20. The onspaces utility 20-1

onspaces Syntax	20-1
onspaces -a: Add a chunk to a dbspace or blobspace	20-2
onspaces -a: Add a chunk to an sbspace	20-3
onspaces -c -b: Create a blobspace	20-5
onspaces -c -d: Create a dbspace.	20-7
Creating a temporary dbspace with the onspaces -t command	20-10
Specifying first and next extent sizes	20-10
Specifying a Non-Default Page Size with the Same Size as the Buffer Pool	20-10
onspaces -c -S: Create an sbspace	20-11
Creating a Temporary Sbspace with the -t Option	20-13
Creating an Sbspace with the -Df option.	20-13
Changing the -Df Settings	20-16
Using the onspaces -g option	20-16
onspaces -c -x: Create an extspace	20-16
onspaces -ch: Change sbspace default specifications	20-17
onspaces -cl: Clean up stray smart large objects in sbspaces	20-18
onspaces -d: Drop a chunk in a dbspace, blobspace, or sbspace	20-19
onspaces -d: Drop a blobspace, dbspace, extspace, or sbspace.	20-20
onspaces -f: Specify DATASKIP parameter	20-21
onspaces -m: Start mirroring.	20-22
Using a File to Specify Chunk-Location Information with the -f Option	20-24
onspaces -r: Stop mirroring	20-24
onspaces -ren: Rename a dbspace, blobspace, sbspace, or extspace	20-25
Renaming a dbspace, blobspace, sbspace, or extspace when Enterprise Replication is active	20-26
Performing an Archive after Renaming a Space	20-26
onspaces -s: Change status of a mirrored chunk	20-26
Avoid overwriting a chunk	20-28

Chapter 21. The onstat utility 21-1

onstat Portal: onstat Utility Commands Sorted by Functional Category	21-2
Monitor the database server status.	21-18
onstat Command Syntax	21-19

onstat command: Equivalent to the onstat -pu command	21-23
onstat - command: Print output header	21-23
onstat - command: Print onstat options and functions	21-24
Running onstat Commands on a Shared Memory Dump File	21-24
onstat -a command: Print overall status of the database server	21-25
onstat -b command: Print buffer information for buffers in use	21-25
onstat -B command: Prints information about used buffers	21-26
onstat -c command: Print ONCONFIG file contents	21-28
onstat -C command: Print B-tree scanner information	21-29
onstat -d command: Print chunk information	21-34
onstat -D command: Print page-read and page-write information	21-39
onstat -f command: Print dbspace information affected by dataskip	21-40
onstat -F command: Print counts	21-40
onstat -g monitoring options	21-42
onstat -g act command: Print active threads	21-48
onstat -g afr command: Print allocated memory fragments	21-48
onstat -g all command: Print diagnostic information.	21-49
onstat -g aqt command: Print data mart and accelerated query table information	21-49
onstat -g arc command: Print archive status	21-52
onstat -g ath command: Print information about all threads	21-54
onstat -g buf command: Print buffer pool profile information	21-55
onstat -g cat command: Print ER global catalog information	21-57
onstat -g cdr command: Print ER statistics	21-58
onstat -g cdr config command: Print ER settings	21-59
onstat -g ckp command: Print checkpoint history and configuration recommendations	21-61
onstat -g cluster command: Print high-availability cluster information.	21-65
onstat -g cmsm command: Print Connection Manager information	21-69
onstat -g con command: Print condition and thread information.	21-71
onstat -g cpu : Print runtime statistics.	21-71
onstat -g dbc command: Print dbScheduler and dbWorker thread statistics	21-73
onstat -g ddr command: Print ER database log reader status	21-74
onstat -g defragment command: Print defragment partition extents	21-75
onstat -g dic command: Print table information	21-76
onstat -g dis command: Print database server information.	21-77
onstat -g dsk command: Print the progress of the currently running compression operation	21-78
onstat -g dll command: Print dynamic link library file list.	21-79
onstat -g dmp command: Print raw memory	21-80
onstat -g dri command: Print high-availability data replication information	21-81
onstat -g dsc command: Print distribution cache information.	21-83
onstat -g dss command: Print ER environment data	21-84
onstat -g dtc command: Print delete table cleaner statistics	21-85
onstat -g env command: Print environment variable values	21-86
onstat -g ffr command: Print free fragments	21-88
onstat -g glo command: Print global multithreading information	21-89
onstat -g grp command: Print ER grouper statistics	21-91
onstat -g his command: Print SQL trace information.	21-97
onstat -g ioa command: Print combined onstat -g information	21-102
onstat -g iob command: Print big buffer use summary	21-103
onstat -g iof command: Print asynchronous I/O statistics	21-104
onstat -g iog command: Print AIO global information.	21-105
onstat -g ioq command: Print I/O queue information	21-105
onstat -g ipl command: Print index page logging status information	21-107
onstat -g iov command: Print AIO VP statistics	21-107
onstat -g lap command: Print light appends status information.	21-109
onstat -g laq command: Print secondary server queues	21-109
onstat -g lmm command: Print low memory management information	21-111
onstat -g lmx command: Print all locked mutexes	21-113
onstat -g lsc command: Print active light scan status (deprecated)	21-114
onstat -g mem command: Print pool memory statistics	21-114
onstat -g mgm command: Print MGM resource information	21-116
onstat -g nbm command: Print a block bit map	21-119

onstat -g nif command: Print statistics about the network interface	21-120
onstat -g nsc command: Print current shared memory connection information.	21-121
onstat -g nsd command: Print poll threads shared-memory data	21-124
onstat -g nss command: Print shared memory network connections status	21-124
onstat -g ntd command: Print network statistics.	21-125
onstat -g ntm command: Print network mail statistics	21-126
onstat -g ntt command: Print network user times	21-126
onstat -g ntu command: Print network user statistics	21-127
onstat -g opn command: Print open partitions	21-127
onstat -g osi : Print operating system information	21-129
onstat -g pos command: Print file values	21-130
onstat -g ppd command: Print partition compression dictionary information	21-131
onstat -g ppf command: Print partition profiles	21-132
onstat -g pqs command: Print operators for all SQL queries	21-133
onstat -g prc command: Print sessions using UDR or SPL routine	21-134
onstat -g proxy command: Print proxy distributor information	21-135
onstat -g que command: Prints ER queue statistics	21-140
onstat -g qst command: Print wait options for mutex and condition queues	21-141
onstat -g rah command: Print read-ahead request statistics	21-142
onstat -g rbm command: Print a block map of shared memory.	21-143
onstat -g rcv command: Print ER receive manager statistics	21-144
onstat -g rea command: Print ready threads	21-147
onstat -g rep command: Print ER schedule manager events	21-148
onstat -g rqm command: Print low-level queue statistics	21-148
onstat -g rss command: Print RS secondary server information.	21-151
onstat -g rwm command: Print read and write mutexes	21-154
onstat -g sch command: Print VP information	21-155
onstat -g scn command: Print scan information	21-155
onstat -g sds command: Print SD secondary server information	21-157
onstat -g seg command: Print shared memory segment statistics	21-161
onstat -g ses command: Print session-related information	21-162
onstat -g sle command: Print all sleeping threads	21-167
onstat -g smb command: Print sbspaces information	21-167
onstat -g smx command: Print multiplexer group information	21-169
onstat -g spi command: Print spin locks with long spins	21-171
onstat -g sql command: Print SQL-related session information	21-172
onstat -g src command: Patterns in shared memory	21-173
onstat -g ssc command: Print SQL statement occurrences.	21-174
onstat -g stk command: Print thread stack.	21-176
onstat -g stm command: Print SQL statement memory usage	21-176
onstat -g stq command: Print queue information	21-177
onstat -g sts command: Print stack usage for each thread.	21-177
onstat -g sym command: Print symbol table information for the oninit utility.	21-178
onstat -g sync command: Print ER synchronization status	21-179
onstat -g tpf command: Print thread profiles	21-180
onstat -g ufr command: Print memory pool fragments	21-181
onstat -g vpcache command: Print CPU VP memory block cache statistics	21-182
onstat -g wai command: Print wait queue thread list	21-184
onstat -g wmx command: Print all mutexes with waiters	21-184
onstat -g wst command: Print wait statistics for threads	21-185
onstat -G command: Print TP/XA transaction information	21-187
onstat -h command: Print buffer header hash chain information	21-188
onstat -i command: Initiate interactive mode	21-189
onstat -j command: Provide onpload status information	21-190
onstat -k command: Print active lock information	21-192
onstat -l command: Print physical and logical log information	21-193
onstat -L command: Print the number of free locks.	21-196
onstat -m command: Print recent system message log information.	21-197
onstat -o command: Output shared memory contents to a file	21-198
onstat -O command: Print optical subsystem information	21-198
onstat -p command: Print profile counts	21-200

onstat -P command: Print partition information	21-203
onstat -r command: Repeatedly print selected statistics	21-204
onstat -R command: Print LRU, FLRU, and MLRU queue information	21-207
onstat -s command: Print latch information	21-209
onstat -t and onstat -T commands: Print tblspace information	21-211
onstat -u command: Print user activity profile	21-212
onstat -x command: Print database server transaction information.	21-215
Determine the position of a logical-log record	21-217
Determine the mode of a global transaction	21-217
onstat -X command: Print thread information	21-217
onstat -z command: Clear statistics	21-219
Return codes on exiting the onstat utility	21-219

Part 3. SQL Administration API

Chapter 22. SQL Administration API Functions. **22-1**

SQL Administration API Overview	22-1
admin() and task() Function Syntax Behavior	22-1
admin() and task() Argument Size Specifications	22-2
admin() and task() Function Return Codes	22-2
SQL administration API portal: Arguments by functional category	22-4
add bufferpool argument: Add a buffer pool (SQL administration API)	22-13
add chunk argument: Add a new chunk (SQL administration API)	22-14
add log argument: Add a new logical log (SQL administration API)	22-16
add memory argument: Increase shared memory (SQL administration API)	22-17
add mirror argument: Add a mirror chunk (SQL administration API)	22-18
alter chunk argument: Change chunk status to online or offline (SQL administration API)	22-19
alter logmode argument: Change the database logging mode (SQL administration API)	22-20
alter plog argument: Change the physical log (SQL administration API)	22-21
archive fake argument: Perform an unrecorded backup (SQL administration API)	22-21
cdr argument: Administer Enterprise Replication (SQL administration API)	22-22
check data argument: Check data consistency (SQL administration API)	22-23
check extents argument: Check extent consistency (SQL administration API).	22-24
check partition argument: Check partition consistency (SQL administration API)	22-24
checkpoint argument: Force a checkpoint (SQL administration API)	22-25
clean sbspace argument: Release unreferenced smart large objects (SQL administration API)	22-26
create blobspace argument: Create a blobspace (SQL administration API).	22-26
create blobspace from storagepool argument: Create a blobspace from the storage pool (SQL administration API)	22-28
create chunk argument: Create a chunk (SQL administration API)	22-29
create chunk from storagepool argument: Create a chunk from the storage pool (SQL administration API).	22-30
create database argument: Create a database (SQL administration API)	22-31
create dbspace argument: Create a dbspace (SQL administration API)	22-32
create dbspace from storagepool argument: Create a dbspace from the storage pool (SQL administration API)	22-33
create sbspace argument: Create an sbspace (SQL administration API)	22-34
create sbspace from storagepool argument: Create an sbspace from the storage pool (SQL administration API)	22-35
create sbspace with accesstime argument: Create an sbspace that tracks access time (SQL administration API)	22-36
create sbspace with log argument: Create an sbspace with transaction logging (SQL administration API)	22-37
create tempdbspace argument: Create a temporary dbspace (SQL administration API)	22-38
create tempdbspace from storagepool argument: Create a temporary dbspace from the storage pool (SQL administration API).	22-39
create tempdsbspace argument: Create a temporary sbspace (SQL administration API).	22-40
create tempdsbspace from storagepool argument: Create a temporary sbspace from the storage pool (SQL administration API).	22-41
defragment argument: Dynamically defragment partition extents	22-42
drop blobspace argument: Drop a blobspace (SQL administration API)	22-43
drop blobspace to storagepool argument: Return space from an empty blobspace to the storage pool (SQL administration API).	22-44
drop chunk argument: Drop a chunk (SQL administration API)	22-44

drop chunk to storagepool argument: Return space from an empty chunk to the storage pool (SQL administration API).	22-46
drop database argument: Drop a database (SQL administration API)	22-46
drop dbspace argument: Drop a dbspace (SQL administration API).	22-47
drop dbspace to storagepool argument: Return space from an empty dbspace to the storage pool (SQL administration API).	22-47
drop log argument: Drop a logical log (SQL administration API)	22-48
drop sbspace argument: Drop an sbspace (SQL administration API)	22-49
drop sbspace to storagepool argument: Return space from an empty sbspace to the storage pool (SQL administration API).	22-49
drop tempdbspace argument: Drop a temporary dbspace (SQL administration API)	22-50
drop tempdbspace to storagepool argument: Return space from an empty temporary dbspace to the storage pool (SQL administration API)	22-51
drop tempsbspace to storagepool argument: Return space from an empty temporary sbspace to the storage pool (SQL administration API)	22-51
file status argument: Display the status of a message log file (SQL administration API)	22-52
ha make primary argument: Change the mode of a secondary server (SQL administration API)	22-53
ha rss argument: Create an RS secondary server (SQL administration API)	22-54
ha rss add argument: Add an RS secondary server to a primary server (SQL administration API)	22-55
ha rss change argument: Change the password of an RS secondary server (SQL administration API)	22-56
ha rss delete argument: Delete an RS secondary server (SQL administration API)	22-57
ha sds clear argument: Stop shared-disk replication (SQL administration API)	22-57
ha sds primary argument: Convert an SD secondary server to a primary server (SQL administration API).	22-58
ha sds set argument: Create a shared-disk primary server (SQL administration API)	22-59
ha set idxauto argument: Replicate indexes to secondary servers (SQL administration API).	22-60
ha set ipl argument: Log index builds on the primary server (SQL administration API)	22-60
ha set primary argument: Define an HDR primary server (SQL administration API)	22-61
ha set secondary argument: Define an HDR secondary server (SQL administration API).	22-62
ha set standard argument: Convert an HDR server into a standard server (SQL administration API).	22-62
ha set timeout argument: Change SD secondary server timeout (SQL administration API)	22-63
message log delete argument: Delete a message log file (SQL administration API)	22-64
message log rotate argument: Rotate the message log file (SQL administration API)	22-64
message log truncate argument: Delete the contents of a message log file (SQL administration API)	22-65
modify chunk extend argument: Extend the size of a chunk (SQL administration API)	22-66
modify chunk extendable argument: Mark a chunk as extendable (SQL administration API)	22-67
modify chunk extendable off argument: Mark a chunk as not extendable (SQL administration API)	22-68
modify space expand argument: Expand the size of a space (SQL administration API)	22-69
modify space sp_sizes argument: Modify the create or extend size of a storage space (SQL administration API)	22-70
onmode and a arguments: Add a shared-memory segment (SQL administration API).	22-72
onmode and c arguments: Force a checkpoint (SQL administration API)	22-73
onmode and C arguments: Control the B-tree scanner (SQL administration API)	22-74
onmode and d arguments: Set data-replication types (SQL administration API).	22-75
onmode and D arguments: Set PDQ priority (SQL administration API)	22-77
onmode and e arguments: Change usage of the SQL statement cache (SQL administration API)	22-77
onmode and F arguments: Free unused memory segments (SQL administration API).	22-78
onmode and j arguments: Switch the database server to administration mode (SQL administration API)	22-79
onmode and l arguments: Switch to the next logical log (SQL administration API).	22-80
onmode and m arguments: Switch to multi-user mode (SQL administration API)	22-80
onmode and M arguments: Temporarily change decision-support memory (SQL administration API)	22-81
onmode and n arguments: Unlock resident memory (SQL administration API)	22-82
onmode and O arguments: Mark a disabled dbspace as down (SQL administration API)	22-82
onmode and p arguments: Add or remove virtual processors (SQL administration API)	22-83
onmode and Q arguments: Set maximum number for decision-support queries (SQL administration API)	22-84
onmode and r arguments: Force residency of shared memory (SQL administration API).	22-85
onmode and S arguments: Set maximum number of decision-support scans (SQL administration API)	22-86
onmode and W arguments: Reset statement cache attributes (SQL administration API)	22-86
onmode and wf arguments: Permanently update a configuration parameter (SQL administration API)	22-88
onmode and wm arguments: Temporarily update a configuration parameter (SQL administration API).	22-89
onmode, wm, and AUTO_LRU_TUNING arguments: Change LRU tuning status (SQL administration API)	22-90
onmode and Y arguments: Change query plan measurements for a session (SQL administration API)	22-91
onmode and z arguments: Terminate a user session (SQL administration API)	22-92

onmode and Z arguments: Terminate a distributed transaction (SQL administration API)	22-93
onbar argument: Backup the storage spaces (SQL administration API)	22-93
onsmsync argument: Synchronize with the storage manager catalog (SQL administration API)	22-95
ontape archive argument: Backup the data on your database (SQL administration API)	22-96
print error argument: Print an error message (SQL administration API)	22-97
print file info argument: Display directory or file information (SQL administration API)	22-98
print partition argument: Print partition information (SQL administration API)	22-99
rename space argument: Rename a storage space (SQL administration API)	22-99
reset sysadmin argument: Move the sysadmin database (SQL administration API)	22-100
restart listen argument: Stop and start a listen thread dynamically (SQL administration API)	22-101
scheduler argument: Stop or start the scheduler (SQL administration API)	22-102
scheduler lmm enable argument: Specify automatic low memory management settings (SQL administration API)	22-102
scheduler lmm disable argument: Stop automatic low memory management (SQL administration API)	22-105
set chunk argument: Change the status of a chunk (SQL administration API)	22-106
set dataskip argument: Start or stop skipping a dbspace (SQL administration API)	22-107
set index compression argument: Change index page compression (SQL administration API)	22-107
set onconfig memory argument: Temporarily change a configuration parameter (SQL administration API)	22-108
set onconfig permanent argument: Permanently change a configuration parameter (SQL administration API)	22-109
set sbspace accesstime argument: Control access time tracking (SQL administration API)	22-110
set sbspace avg_lo_size argument: Set the average size of smart large objects (SQL administration API)	22-111
set sbspace logging argument: Change the logging of an sbspace (SQL administration API)	22-112
set sql tracing argument: Set global SQL tracing (SQL administration API)	22-112
set sql tracing database argument: Change database tracing (SQL administration API)	22-114
set sql tracing session argument: Control tracing for a session (SQL administration API)	22-115
set sql tracing user argument: Control tracing for users (SQL administration API)	22-116
set sql user tracing argument: Set global SQL tracing for a user session (SQL administration API)	22-116
start listen argument: Start a listen thread dynamically (SQL administration API)	22-117
start mirroring argument: Starts storage space mirroring (SQL administration API)	22-118
stop listen argument: Stop a listen thread dynamically (SQL administration API)	22-118
stop mirroring argument: Stops storage space mirroring (SQL administration API)	22-119
storagepool add argument: Add a storage pool entry (SQL administration API)	22-120
storagepool delete argument: Delete one storage pool entry (SQL administration API)	22-122
storagepool modify argument: Modify a storage pool entry (SQL administration API)	22-123
storagepool purge argument: Delete storage pool entries (SQL administration API)	22-125
Table and fragment compress and uncompress operations (SQL administration API)	22-126
table or fragment arguments: Compress data and optimize storage (SQL administration API)	22-127
Output of the estimate compression operation (SQL administration API)	22-132
purge compression dictionary arguments: Remove compression dictionaries (SQL administration API)	22-133

Part 4. Appendixes

Appendix A. Files That the Database Server Uses. A-1

Database server files	A-1
Descriptions of Files	A-4
af.xxx	A-4
ac_msg.log	A-4
ac_config.std	A-4
bar_act.log	A-4
bldutil.process_id	A-5
buildsmi.out (UNIX) or buildsmi_out (Windows)	A-5
concdr.sh	A-5
.conf.dbservername	A-5
core	A-5
Emergency Boot Files for ON-Bar	A-5
gcore.xxx (UNIX)	A-6
illlsra.xx	A-6
~/informix	A-6
informix.rc (UNIX)	A-6
INFORMIXTMP	A-6

.inf.servicename	A-7
.infos.dbservername	A-7
.infxdirs	A-7
InstallServer.log (Windows)	A-7
ISM catalog	A-7
ISM logs	A-7
ISMversion file.	A-8
JVM_vpid file	A-8
JVPLOG	A-8
.jvpprops.	A-8
Message Log	A-8
onconfig.std.	A-8
The ONCONFIG File.	A-9
onconfig	A-9
oncfg_servername.servernum	A-9
onsnmp.servername.	A-10
onsrvapd.log	A-10
revcdr.sh	A-10
shmem.xxx (UNIX)	A-10
sm_versions.std	A-10
snmpd.log	A-10
sqlhosts	A-10
VP.servername.nnx	A-11
xbsa.messages.	A-11

Appendix B. Troubleshooting errors B-1

Collecting Diagnostics using onmode -I.	B-1
Creating Tracepoints	B-1
Collecting data with the ifxcollect tool	B-1

Appendix C. Event Alarms C-1

Using ALARMPROGRAM to Capture Events.	C-1
Setting ALRM_ALL_EVENTS	C-1
Writing Your Own Alarm Script	C-1
Customizing the ALARMPROGRAM Scripts	C-1
Precautions for Foreground Operations in Alarm Scripts	C-2
Interpreting event alarm messages	C-2
Events in the ph_alert Table	C-3
Event Alarm Parameters.	C-4
Event alarm IDs	C-6
Severity 5 event alarms.	C-53
Connection Manager event alarm IDs	C-57

Appendix D. Discontinued configuration parameters D-1

AFF_NPROCS (Discontinued)	D-2
AFF_SPROC (Discontinued)	D-2
BUFFERS (Discontinued)	D-3
FAST_RESTART_CKPT_FUZZYLOG (Discontinued)	D-4
FAST_RESTART_PHYSLOG (Discontinued)	D-4
JDKVERSION (Discontinued)	D-5
LBU_PRESERVE (Discontinued)	D-5
LOGSMAX (Discontinued)	D-5
LRU_MAX_DIRTY (Discontinued)	D-6
LRU_MIN_DIRTY (Discontinued)	D-6
LRUS (Discontinued).	D-7
NOAGE (Discontinued)	D-7
NUMAIOVPS (Discontinued)	D-8
NUMCPUVPS (Discontinued)	D-8
PHYSDBS (Discontinued)	D-9
RA_THRESHOLD configuration parameter (discontinued)	D-10

Appendix E. Error Messages	E-1
How the Messages Are Ordered in This Chapter	E-1
How to View These Messages	E-1
Message Categories	E-2
Messages: A-B	E-2
Aborting Long Transaction: <i>tx Oxn</i>	E-2
Affinitied VP <i>mm</i> to phys proc <i>nn</i>	E-2
Affinity not enabled for this server.	E-3
Assert Failed: Error from SBSpace cleanup thread.	E-3
Assert Failed: Short description of what failed Who: Description of user/session/thread running at the time Result: State of the affected database server entity Action: What action the database administrator should take See Also: DUMPDIR/af.uniqid containing more diagnostics..	E-3
Begin re-creating indexes deferred during recovery..	E-3
Building 'sysmaster' database requires ~ <i>mm</i> pages of logical log. Currently there are <i>nn</i> pages available. Prepare to back up your logs soon.	E-4
Building 'sysmaster' database...	E-4
Messages: C	E-4
Cannot Allocate Physical-log File, <i>mm</i> wanted, <i>nn</i> available.	E-4
Cannot alter a table which has associated violations table.	E-4
Cannot change to mode..	E-4
Cannot Commit Partially Complete Transactions.	E-5
Cannot create a user-defined VP class with 'SINGLE_CPU_VP' non-zero.	E-5
Cannot create violations/diagnostics table.	E-5
Cannot insert from the violations table to the target table.	E-6
Cannot modify/drop a violations/diagnostics table.	E-6
Cannot Open Dbspace <i>mmm</i>	E-6
Cannot Open Logical Log.	E-7
Cannot Open Mirror Chunk <i>pathname</i> , errno = <i>nn</i>	E-7
Cannot Open Primary Chunk <i>pathname</i> , errno = <i>mmm</i>	E-7
Cannot Open Primary Chunk <i>chunkname</i>	E-7
Cannot open sysams in database <i>name</i> , iserrno <i>number</i>	E-7
Cannot open sysdistrib in database <i>name</i> , iserrno <i>number</i>	E-8
Cannot open <i>system_table</i> in database <i>name</i> , iserrno <i>number</i>	E-8
Cannot open systrigbody in database <i>name</i> , iserrno <i>number</i>	E-8
Cannot open systriggers in database <i>name</i> , iserrno <i>number</i>	E-8
Cannot open sysxtotypes in database <i>name</i> , iserrno <i>number</i>	E-8
Cannot Perform Checkpoint, shut system down..	E-8
Cannot Restore to Checkpoint..	E-9
Cannot Rollback Incomplete Transactions.	E-9
Cannot update pagezero.	E-9
Cannot update syscasts in database <i>name</i> . Iserrno <i>number</i>	E-9
Can't affinity VP <i>mm</i> to phys proc <i>nn</i>	E-10
Changing the sbspace minimum extent value: old value <i>value1</i> , new value <i>value2</i>	E-10
Checkpoint blocked by down space, waiting for override or shutdown.	E-10
Checkpoint Completed: duration was <i>n</i> seconds.	E-10
Checkpoint Page Write Error.	E-10
Checkpoint Record Not Found in Logical Log.	E-11
Chunk <i>chunkname</i> added to space <i>spacename</i>	E-11
Chunk <i>chunkname</i> dropped from space <i>spacename</i>	E-11
Chunk <i>number nn pathname</i> -- Offline.	E-11
Chunk <i>number nn pathname</i> -- Online.	E-11
The chunk <i>pathname</i> must have READ/WRITE permissions for owner and group.	E-12
The chunk <i>pathname</i> must have <i>owner-ID</i> and <i>group-ID</i> set to informix.	E-12
The chunk <i>pathname</i> will not fit in the space specified.	E-12
Cleaning stray LOs in sbspace <i>sbspacename</i>	E-12
Completed re-creating indexes.	E-12
Configuration has been grown to handle up to <i>integer</i> chunks.	E-13
Configuration has been grown to handle up to <i>integer</i> dbslices.	E-13
Configuration has been grown to handle up to <i>integer</i> dbspaces.	E-13
Continuing Long Transaction (for COMMIT): <i>tx Oxn</i>	E-13
Could not disable priority aging: errno = <i>number</i>	E-13

Could not fork a virtual processor: errno = <i>number</i> .	E-14
Create_vp: cannot allocate memory.	E-14
Messages: D-E-F	E-14
Dataskip is OFF for all dbspaces.	E-14
Dataskip is ON for all dbspaces..	E-14
Dataskip is ON for dbspaces: <i>dbspacelist</i> .	E-14
Dataskip will be turned {ON OFF} for <i>dbspacename</i> .	E-15
DBSERVERALIASES exceeded the maximum limit of 32.	E-15
DBSPACETEMP internal list not initialized, using default.	E-15
The DBspace/BLOBspace <i>spacename</i> is now mirrored.	E-15
The DBspace/BLOBspace <i>spacename</i> is no longer mirrored.	E-15
Dbpace <i>dbspacename</i> for Physical-log File not found.	E-16
<i>devname</i> : write failed, file system is full.	E-16
Dropping temporary tblspace <i>0xn</i> , recovering <i>nn</i> pages.	E-16
Dynamically allocated new shared memory segment (size <i>nnnn</i>).	E-16
ERROR: NO "wait for" locks in Critical Section.	E-16
Error building sysmaster database. See <i>outfile</i> .	E-17
Error in dropping system defined type.	E-17
Error in renaming systdist.	E-17
Error removing sysdistrib row for <i>tabid = tabid</i> , <i>colid = colid</i> in database <i>name</i> . <i>iserrno = number</i>	E-17
Error writing <i>pathname</i> errno = <i>number</i> .	E-17
Error writing shmем to file <i>filename</i> (<i>error</i>). Unable to create output file <i>filename</i> errno= <i>mm</i> .Error writing <i>filename</i> errno= <i>nn</i> .	E-18
Fail to extend physical log space.	E-18
Fatal error initializing CWD string. Check permissions on current working directory. Group <i>groupname</i> must have at least execute permission on '..'	E-18
The following tables have outstanding old version data pages due to an In-Place Alter Table. Perform UPDATE <i>tablename</i> SET <i>column = column</i> WHERE 1=1; to clear these pages from the following tables.	E-18
Fragments <i>dbspacename1 dbspacename2</i> of table <i>tablename</i> set to non-resident.	E-19
Forced-resident shared memory not available.	E-19
Freed <i>mm</i> shared-memory segment(s) <i>number</i> bytes.	E-19
Messages: G-H-I	E-19
gcore <i>pid</i> ; mv <i>core.pid</i> dir/ <i>core.pid</i> .ABORT.	E-19
I/O <i>function</i> chunk <i>mm</i> , <i>pagenum nn</i> , <i>pagecnt aa</i> --> <i>errno = bb</i> .	E-20
I/O error, <i>primary/mirror</i> Chunk <i>pathname</i> -- Offline (<i>sanity</i>).	E-20
Informix <i>database_server</i> Initialized - Complete Disk Initialized.	E-20
Informix <i>database_server</i> Initialized - Shared Memory Initialized.	E-20
Informix <i>database_server</i> Stopped.	E-21
ERROR: Insufficient available disk in the root dbspace to increase the entire Configuration save area.	E-21
Insufficient available disk in the root dbspace for the CM save area. Increase the size of the root dbspace in the ONCONFIG file and reinitialize the server.	E-21
Internal overflow of <i>shmids</i> , increase system max shared memory segment size.	E-22
Messages: J-K-L-M	E-22
Listener-thread err = <i>error_number: error_message</i> .	E-22
Lock table overflow - user id <i>mm</i> session id <i>nn</i> .	E-22
Logical-log File not found..	E-22
Logical Log <i>nn</i> Complete.	E-22
Logical logging <i>vbrerror</i> for <i>type:subtype</i> in (<i>failed_system</i>).	E-23
Log Record: log = <i>ll</i> , pos = <i>0xn</i> , type = <i>type:subtype(snum)</i> , trans = <i>xx</i>	E-23
Log record (<i>type:subtype</i>) at log <i>nn</i> , <i>0xn</i> was not undone..	E-23
Log record (<i>type:subtype</i>) failed, partnum <i>pnum</i> row <i>rid</i> <i>iserrno num</i> .	E-24
Log record (<i>type:subtype</i>) in log <i>nn</i> , offset <i>0xn</i> was not rolled back.	E-24
Logical Recovery allocating <i>nn</i> worker threads <i>thread_type</i> .	E-24
Logical Recovery Started.	E-25
Maximum server connections <i>number</i> .	E-25
Memory allocation error.	E-25
Mirror Chunk <i>chunkname</i> added to space <i>spacename</i> . Perform manual recovery.	E-25
Mixed transaction result. (<i>pid=nn</i> user= <i>userid</i>).	E-26
mt_shm_free_pool: pool <i>0xn</i> has blocks still used (id <i>nn</i>).	E-26
mt_shm_init: can't create <i>resident/virtual</i> segment.	E-26
mt_shm_remove: WARNING: may not have removed all/correct segments.	E-26

Messages: N-O-P	E-27
Newly specified value of <i>value</i> for the pagesize in the configuration file does not match older value of <i>value</i> .	
Using the older value.	E-27
Not enough main memory.	E-27
Not enough logical-log files, Increase LOGFILES.	E-27
Not enough physical procs for affinity.	E-27
The number of configured CPU poll threads exceeds NUMCPUVPS.	E-28
onconfig parameter <i>parameter</i> modified from <i>old_value</i> to <i>new_value</i>	E-28
oninit: Cannot have SINGLE_CPU_VP non-zero and number of CPU VPs greater than 1.	E-28
oninit: Cannot have SINGLE_CPU_VP non-zero and user-defined VP classes.	E-28
oninit: Cannot mix VPCLASS cpu and NUMCPUVPS, AFF_SPROC, AFF_NPROCS, or NOAGE parameters.	E-29
oninit: Cannot mix VPCLASS aio and NUMAIOVPS parameters.	E-29
oninit: Fatal error in initializing ASF with 'ASF_INIT_DATA' flags asfcode = '25507'.	E-29
oninit: invalid or missing name for Subsystem Staging Blobspace.	E-29
Cannot alter a table which has associated violations table.	E-30
oninit: Too many VPCLASS parameters specified.	E-30
oninit: VPCLASS <i>classname</i> bad affinity specification.	E-30
oninit: VPCLASS <i>classname</i> duplicate class <i>name</i>	E-30
oninit: VPCLASS <i>classname</i> illegal option.	E-30
oninit: VPCLASS <i>classname</i> maximum number of VPs is out of the range 0-10000.	E-31
oninit: VPCLASS <i>classname</i> name is too long. Maximum length is <i>maxlength</i>	E-31
oninit: VPCLASS <i>classname</i> number of VPs is greater than the maximum specified.	E-31
oninit: VPCLASS <i>classname</i> number of VPs is out of the range 0-10000.	E-31
onmode: VPCLASS <i>classname</i> name is too long. Maximum length is <i>maxlength</i>	E-32
Optical Subsystem is running.	E-32
Optical Subsystem is not running.	E-32
Optical Subsystem STARTUP Error.	E-32
Online Mode.	E-32
onspaces: unable to reset dataskip.	E-33
Open transaction detected when changing log versions.	E-33
Out of message shared memory.	E-33
Out of resident shared memory.	E-33
Out of virtual shared memory.	E-33
PANIC: Attempting to bring system down.	E-34
Participant site <i>database_server</i> heuristically rolled back.	E-34
Physical recovery complete: <i>number</i> pages examined, <i>number</i> pages restored.	E-34
Physical recovery started at page (<i>chunk:offset</i>).	E-34
Portions of partition partnum of table tablename in database dbname were not logged. This partition cannot be rolled forward.	E-35
Possible mixed transaction result.	E-35
Prepared participant site <i>server_name</i> did not respond.	E-35
Prepared participant site <i>server_name</i> not responding.	E-35
Messages: Q-R-S	E-36
Quiescent Mode.	E-36
Read failed. Table <i>name</i> , Database <i>name</i> , iserrno = <i>number</i>	E-36
Recovery Mode.	E-36
Recreating index: ' <i>dbname:"owner".tablename-idxname</i> '.	E-36
Rollforward of log record failed, iserrno = <i>nn</i>	E-37
Root chunk is full and no additional pages could be allocated to chunk descriptor page.	E-37
scan_logundo: subsys <i>ss</i> , type <i>tt</i> , iserrno <i>ee</i>	E-37
Session completed abnormally. Committing <i>tx</i> id <i>0xm</i> , flags <i>0xn</i>	E-37
Session completed abnormally. Rolling back <i>tx</i> id <i>0xm</i> , flags <i>0xn</i>	E-38
semctl: errno = <i>nn</i>	E-38
semget: errno = <i>nn</i>	E-38
shmat: <i>some_string</i> os_errno: <i>os_err_text</i>	E-38
shmctl: errno = <i>nn</i>	E-38
shmdt: errno = <i>nn</i>	E-39
shmenv sent to <i>filename</i>	E-39
shmget: <i>some_str</i> os_errno: key <i>shmkey</i> : <i>some_string</i>	E-39
Shutdown (onmode -k) or override (onmode -O).	E-39
Shutdown Mode.	E-40

Space <i>spacename</i> added.	E-40
Space <i>spacename</i> dropped.	E-40
Space <i>spacename</i> -- Recovery Begins(<i>addr</i>).	E-40
Space <i>spacename</i> -- Recovery Complete(<i>addr</i>).	E-40
Space <i>spacename</i> -- Recovery Failed(<i>addr</i>).	E-41
sysmaster database built successfully.	E-41
Successfully extend physical log space.	E-41
Messages: T-U-V	E-41
This ddl operation is not allowed due to deferred constraints pending on this table and dependent tables.	E-41
This type of space does not accept log files.	E-42
TIMER VP: Could not redirect I/O in initialization, errno = <i>nn</i>	E-42
Too Many Active Transactions.	E-42
Too many violations.	E-42
Transaction Not Found..	E-43
Transaction heuristically rolled back.	E-43
Transaction table overflow - user id <i>nn</i> , process id <i>nn</i>	E-43
Unable to create output file <i>filename</i> errno = <i>nn</i>	E-43
Unable to extend <i>nn</i> reserved pages for <i>purpose</i> in root chunk.	E-43
Unable to initiate communications with the Optical Subsystem.	E-44
Unable to start SQL engine.	E-44
Unable to open tblspace <i>nn</i> , iserrno = <i>nn</i>	E-44
The value of pagesize <i>pagesize</i> specified in the config file is not a valid pagesize. Use 2048, 4096 or 8192 as the value for PAGESIZE in the onconfig file and restart the server.	E-44
Violations table is not started for the target table.	E-45
Violations table reversion test completed successfully.	E-45
Violations table reversion test failed.	E-45
Violations table reversion test start..	E-45
Violations tables still exist..	E-45
Virtual processor limit exceeded.	E-46
VPCLASS <i>classname</i> name is too long. Maximum length is <i>maxlength</i>	E-46
VPCLASS <i>classname</i> duplicate class name.	E-46
VPCLASS <i>classname</i> Not enough physical procs for affinity..	E-46
Messages: W-X-Y-Z	E-47
WARNING: aio_wait: errno = <i>nn</i>	E-47
WARNING: Buffer pool size may cause database server to get into a locked state. Recommended minimum buffer pool size is <i>num</i> times maximum concurrent user threads..	E-47
warning: Chunk time stamps are invalid..	E-47
Warning: <i>name_old</i> is a deprecated onconfig parameter. Use <i>name_new</i> instead. See the release notes and the Informix Administrator's Reference for more information.	E-47
Warning: <i>name_old</i> is a deprecated onconfig parameter. Use <i>name_new</i> instead.	E-48
Warning: Unable to allocate requested big buffer of size <i>nn</i>	E-48
You are turning off smart large object logging.	E-48
Messages: Symbols	E-48
HH:MM:SS Informix database server Version R.VV.PPPPP Software Serial Number RDS#YYYYYYY..	E-48
<i>argument</i> : invalid argument.	E-49
<i>function_name</i> : cannot allocate memory.	E-49
Conversion/Reversion Messages	E-49
Messages: A-C.	E-49
Messages: D-F.	E-52
Messages: I-P	E-54
Messages: R-W	E-58
Conversion and Reversion Messages for Enterprise Replication	E-61
CDR reversion test completed successfully.	E-62
CDR reversion test failed; for details look in \$INFORMIXDIR/etc/revtestcdr.out.	E-62
Enterprise Replication is not ready for conversion. The Control and TRG send queues should be empty for conversion/reversion to proceed.	E-62
Enterprise Replication is not ready for conversion. The syscdr database should NOT contain old-style group definitions for conversion to succeed.	E-63
Enterprise Replication should be in a stopped state for conversion/reversion to proceed..	E-63
Reversion of 'syscdr' failed; for details look in \$INFORMIXDIR/etc/revcdr.out..	E-63
Starting CDR reversion test...	E-63

Starting 'syscdr' conversion...	E-64
Starting 'syscdr' reversion...	E-64
'syscdr' conversion completed successfully.	E-64
'syscdr' conversion failed. For details, look in \$INFORMIXDIR/etc/concdr.out.	E-64
Syscdr should NOT contain new replicate sets for reversion to succeed.	E-65
Syscdr should not contain replicates defined with the --floatieee option for reversion to succeed.	E-65
Dynamic Log Messages.	E-65
Dynamically added log file <i>logid</i> to DBspace <i>dbspace_number</i> .	E-65
Log file <i>logid</i> added to DBspace <i>dbspace_number</i> .	E-65
Log file number <i>logid</i> has been dropped from DBspace <i>dbspace_number</i> .	E-66
Log file <i>logid</i> has been pre-dropped.	E-66
Pre-dropped log file number <i>logid</i> has been deleted from DBspace <i>dbspace_number</i> .	E-66
ALERT: Because the oldest logical log (<i>logid</i>) contains records from an open transaction (<i>transaction_address</i>), the server is attempting to dynamically add a log file. But there is no space available. Please add a DBspace or chunk. Then complete the transaction as soon as possible.	E-66
ALERT: The oldest logical log (<i>logid</i>) contains records from an open transaction (<i>transaction_address</i>). Logical logging will remain blocked until a log file is added. Add the log file with the onparams -a command, using the -i (insert) option, as in: onparams -a -d <i>dbspace</i> -s <i>size</i> -i. Then complete the transaction as soon as possible.	E-67
Log file <i>logid</i> has been pre-dropped. It will be deleted from the log list and its space can be reused once you take level-0 archives of all BLOBspaces, Smart BLOBspaces and non-temporary DBspaces.	E-67
Sbpace Metadata Messages	E-67
Allocated <i>number</i> pages to Metadata from chunk <i>number</i> .	E-67
Allocated <i>number</i> pages to Userdata from chunk <i>number</i> .	E-67
Freeing reserved space from chunk <i>number</i> to Metadata.	E-68
Freeing reserved space from chunk <i>number</i> to Userdata.	E-68
Truncate Table Messages	E-68
The table cannot be truncated if it has an open cursor or dirty readers.	E-68
The table cannot be truncated. It has at least one non-empty child table with referential constraints.	E-68

Appendix F. Limits in Informix F-1

Limitations on UNIX Operating Systems	F-1
System-Level Parameter Limits (UNIX)	F-1
Table-level parameter limits (UNIX)	F-1
Access capabilities (UNIX)	F-2
Informix System Defaults (UNIX)	F-2
ON-Monitor Statistics (UNIX)	F-3
Limitations on Windows Operating Systems	F-3
System-Level Parameter Limits (Windows)	F-3
Table-level parameter limits (Windows)	F-3
Access Capabilities (Windows)	F-4
Informix System Defaults (Windows)	F-5

Appendix G. Accessibility G-1

Accessibility features for IBM Informix products	G-1
Accessibility features	G-1
Keyboard navigation	G-1
Related accessibility information	G-1
IBM and accessibility	G-1
Dotted decimal syntax diagrams	G-1

Notices H-1

Trademarks	H-3
------------	-----

Index X-1

Introduction

This introduction provides an overview of the information in this publication and describes the conventions that this publication uses.

About This Publication

This publication provides reference material for IBM® Informix®. This publication contains comprehensive descriptions of the configuration parameters, the system-monitoring interface (SMI) tables in the **sysmaster** database, the syntax for database server utilities such as **onmode** and **onstat**, logical-log records, disk structures, event alarms, and unnumbered error messages. This publication has two companion volumes, the *IBM Informix Administrator's Guide* and the *IBM Informix Performance Guide*.

This section discusses the intended audience for this publication and the associated software products that you must have to use the administrative utilities.

Types of Users

This publication is written for the following users:

- Database administrators
- System administrators
- Performance engineers

This publication is written with the assumption that you have the following background:

- A working knowledge of your computer, your operating system, and the utilities that your operating system provides
- Some experience working with relational databases or exposure to database concepts
- Some experience with database server administration, operating-system administration, or network administration

You can access the Informix information centers, as well as other technical information such as technotes, white papers, and IBM Redbooks® publications online at <http://www.ibm.com/software/data/sw-library/>.

Software Dependencies

This publication is written with the assumption that you are using IBM Informix or IBM Informix Dynamic Server with J/Foundation, Version 11.70, as your database server.

Assumptions about your locale

IBM Informix products can support many languages, cultures, and code sets. All the information related to character set, collation and representation of numeric data, currency, date, and time that is used by a language within a given territory and encoding is brought together in a single environment, called a Global Language Support (GLS) locale.

The IBM Informix OLE DB Provider follows the ISO string formats for date, time, and money, as defined by the Microsoft OLE DB standards. You can override that default by setting an Informix environment variable or registry entry, such as **DBDATE**.

If you use Simple Network Management Protocol (SNMP) in your Informix environment, note that the protocols (SNMPv1 and SNMPv2) recognize only English code sets. For more information, see the topic about GLS and SNMP in the *IBM Informix SNMP Subagent Guide*.

The examples in this publication are written with the assumption that you are using one of these locales: en_us.8859-1 (ISO 8859-1) on UNIX platforms or en_us.1252 (Microsoft 1252) in Windows environments. These locales support U.S. English format conventions for displaying and entering date, time, number, and currency values. They also support the ISO 8859-1 code set (on UNIX and Linux) or the Microsoft 1252 code set (on Windows), which includes the ASCII code set plus many 8-bit characters such as é, è, and ñ.

You can specify another locale if you plan to use characters from other locales in your data or your SQL identifiers, or if you want to conform to other collation rules for character data.

For instructions about how to specify locales, additional syntax, and other considerations related to GLS locales, see the *IBM Informix GLS User's Guide*.

Demonstration databases

The DB-Access utility, which is provided with your IBM Informix database server products, includes one or more of the following demonstration databases:

- The **stores_demo** database illustrates a relational schema with information about a fictitious wholesale sporting-goods distributor. Many examples in IBM Informix publications are based on the **stores_demo** database.
- The **superstores_demo** database illustrates an object-relational schema. The **superstores_demo** database contains examples of extended data types, type and table inheritance, and user-defined routines.

For information about how to create and populate the demonstration databases, see the *IBM Informix DB-Access User's Guide*. For descriptions of the databases and their contents, see the *IBM Informix Guide to SQL: Reference*.

The scripts that you use to install the demonstration databases are in the `$INFORMIXDIR/bin` directory on UNIX platforms and in the `%INFORMIXDIR%\bin` directory in Windows environments.

What's New in Administrator's Reference for Informix database server, Version 11.70

This publication includes information about new features and changes in existing functionality.

The following changes and enhancements are relevant to this publication. For a complete list of what's new in this release, see the release notes or the information center at http://publib.boulder.ibm.com/infocenter/idshelp/v117/topic/com.ibm.po.doc/new_features.htm.

The following table lists the new features for Version 11.70.xC5.

Table 1. What's New in IBM Informix Administrator's Reference for Version 11.70.xC5

Overview	Reference
Plan responses to medium-severity and low-severity event alarms You can plan responses to severity 3, 2, and 1 event alarms for alarms with documented explanations and user actions.	"Event alarm IDs" on page C-6
You can use the PN_STAGELOB_THRESHOLD configuration parameter to reserve space for BYTE and TEXT data in round-robin fragments.	"PN_STAGELOB_THRESHOLD configuration parameter" on page 1-114

The following table lists the new features for Version 11.70.xC4.

Table 2. What's New in IBM Informix Administrator's Reference for Version 11.70.xC4

Overview	Reference
Use a file to authenticate server connections in a secured network environment You can use the S6_USE_REMOTE_SERVER_CFG configuration parameter with the REMOTE_SERVER_CFG configuration parameter to specify the file that is used to authenticate connections in a secured network environment.	"S6_USE_REMOTE_SERVER_CFG configuration parameter" on page 1-125
Configure secure connections for replication servers You can use the connection security option in the sqlhosts file and create an encrypted password file so that the Connection Manager and the CDR utility can securely connect to networked servers. Use the onpassword utility to encrypt or decrypt a password file.	Chapter 18, "The onpassword utility," on page 18-1
Data sampling for update statistics operations If you have a large index with more than 100 000 leaf pages, you can generate index statistics based on sampling when you run UPDATE STATISTICS statements in LOW mode. Gathering index statistics from sampled data can increase the speed of the update statistics operations. To enable sampling, set the USTLOW_SAMPLE configuration parameter or the USTLOW_SAMPLE option of the SET ENVIRONMENT statement.	"USTLOW_SAMPLE configuration parameter" on page 1-166
SQL administration API command arguments for creating sbspaces Three SQL administration API command arguments were added: create tempsbpace (creates temporary sbspaces), create sbspace with log (creates sbspaces that have transaction logging turned on), create sbspace with accesstime (creates sbspaces that track the time of access for all smart large objects stored in the sbspace).	"create tempsbpace argument: Create a temporary sbspace (SQL administration API)" on page 22-40 "create sbspace with log argument: Create an sbspace with transaction logging (SQL administration API)" on page 22-37 "create sbspace with accesstime argument: Create an sbspace that tracks access time (SQL administration API)" on page 22-36

<p>Dynamically change additional configuration parameters</p> <p>In past releases you could dynamically change some configuration parameters with the onmode -wf or onmode -wm commands. As of this fix pack, you can use those commands to dynamically change these additional configurations parameters: ALARMPROGRAM, AUTO_REPREPARE, BLOCKTIMEOUT, CKPTINTVL, DBSPACETEMP, DEADLOCK_TIMEOUT, DEF_TABLE_LOCKMODE, DIRECTIVES, DRINTERVAL, DRTIMEOUT, FILLFACTOR, LOGSIZE, LTAPEBLK, LTAPEDEV, LTAPESIZE, MSGPATH, ONDBSPACEDOWN, OPTCOMPIND, RA_PAGES, SHMADD, STACKSIZE, SYSALARMPROGRAM, TAPEBLK, TAPEDEV, TAPESIZE, TBLTBLFIRST, TBLTBLNEXT, TXTIMEOUT, and WSTATS.</p>	<p>“onmode -wf, -wm: Dynamically change certain configuration parameters” on page 15-26</p>
<p>Plan responses to high severity event alarms</p> <p>You can plan responses to severity 4 and 5 event alarms based on the documented explanations and user actions.</p>	<p>“Event alarm IDs” on page C-6</p> <p>“Severity 5 event alarms” on page C-53</p>
<p>Monitor client program database usage</p> <p>You can use the onstat -g ses sessionid command to display the full path of the client program that is used in your session. Use the client program information to monitor or stop access to the database.</p>	<p>“onstat -g ses command: Print session-related information” on page 21-162</p>
<p>Progress of compression operations</p> <p>When you run an onstat -g dsk command to display information about currently running compression operations, you can find useful information in two new columns: The Approx Prog column shows the percentage completed of the operation that is in progress, and the Approx Remaining column shows the approximate time remaining that is required to complete the operation.</p>	<p>“onstat -g dsk command: Print the progress of the currently running compression operation” on page 21-78</p>
<p>Prevent failover if the primary server is active</p> <p>Use the SDS_LOGCHECK configuration parameter to prevent a shared-disk (SD) secondary server from taking over the role of the primary server. Failover to the SD secondary server is initiated if the primary server is inactive, and is not allowed if the primary server is active. This configuration parameter is useful if you do not have I/O fencing configured and your system consists of a primary server and one or more SD secondary servers.</p>	<p>“SDS_LOGCHECK configuration parameter” on page 1-130</p>
<p>Global Security Kit (GSKit) support</p> <p>Informix 11.70 now supports GSKit version 7 or later, and ships with GSKit version 8. You can set the GSKIT_VERSION configuration parameter so that the database server uses a version other than GSKit version 8.</p>	<p>“GSKIT_VERSION configuration parameter” on page 1-82</p>

The following table lists the new features for Version 11.70.xC3.

Table 3. What's New in IBM Informix Administrator's Reference for Version 11.70.xC3

Overview	Reference
<p>Automatic read-ahead operations</p> <p>You can enable the database server to use read-ahead operations automatically to improve performance. Most queries can benefit from processing the query while asynchronously retrieving the data required by the query. The database server can automatically use asynchronous operations for data or it can avoid them if the data for the query is already cached. Use the <code>AUTO_READAHEAD</code> configuration parameter to configure automatic read-ahead operations for all queries, and use the <code>SET ENVIRONMENT AUTO_READAHEAD</code> statement to configure automatic read-ahead operations for a particular session.</p> <p>The <code>RA_THRESHOLD</code> configuration parameter is deprecated with this release.</p>	<p>"<code>AUTO_READAHEAD</code> configuration parameter" on page 1-30</p> <p>"<code>onstat -g rah</code> command: Print read-ahead request statistics" on page 21-142</p>
<p>Managing message logs in embedded and enterprise environments</p> <p>You can use Scheduler tasks to reduce the size of message log files by automatically truncating or deleting the log files or by configuring automatic file rotation. Additionally, you can use the related ph_threshold table parameters to specify the maximum number of message log files to retain. These tasks and parameters are useful for embedded applications because they reduce DBA or system administrator requirements for managing the log files.</p> <p>You can also use SQL administration API commands to manage the size of the log files on demand, as necessary.</p>	<p>"message log rotate argument: Rotate the message log file (SQL administration API)" on page 22-64</p> <p>"message log truncate argument: Delete the contents of a message log file (SQL administration API)" on page 22-65</p> <p>"message log delete argument: Delete a message log file (SQL administration API)" on page 22-64</p> <p>"file status argument: Display the status of a message log file (SQL administration API)" on page 22-52</p>
<p>Configuring the server response to low memory</p> <p>You can configure the actions that the server takes to continue processing when memory is critically low. You can specify the criteria for terminating sessions based on idle time, memory usage, and other factors so that the targeted application can continue and avoid out-of-memory problems. Configuring the low memory response is useful for embedded applications that have memory limitations.</p>	<p>"<code>LOW_MEMORY_MGR</code> configuration parameter" on page 1-91</p> <p>"<code>onstat -g lmm</code> command: Print low memory management information" on page 21-111</p> <p>"scheduler lmm enable argument: Specify automatic low memory management settings (SQL administration API)" on page 22-102</p> <p>"scheduler lmm disable argument: Stop automatic low memory management (SQL administration API)" on page 22-105</p>
<p>Reserving memory for critical activities</p> <p>You can enable the server to reserve a specific amount of memory for use when critical activities (such as rollback activities) are needed and the server has limited free memory. If you enable the new <code>LOW_MEMORY_RESERVE</code> configuration parameter by setting it to a specified value in kilobytes, the critical activities can complete even when you get out-of-memory errors. You can also dynamically adjust the value of the <code>LOW_MEMORY_RESERVE</code> configuration parameter with the <code>onmode -wm</code> or <code>-wf</code> command.</p>	<p>"<code>LOW_MEMORY_RESERVE</code> configuration parameter" on page 1-92</p>

Table 3. What's New in IBM Informix Administrator's Reference for Version 11.70.xC3 (continued)

Overview	Reference
<p>Connection Manager enhancements</p> <p>You can configure a single Connection Manager instance to automatically manage client connection requests for a combination of high availability clusters, grids, server sets, and Enterprise Replication (ER) servers.</p> <p>Before version 3.70.xC3 you had to use a separate Connection Manager instance to manage each type of connection unit. For example, you had to use one Connection Manager instance for database servers that were in a grid and another Connection Manager instance for database servers that were in a high-availability cluster.</p> <p>To make configuration easier, most of the command-line options are deprecated and options are set using the configuration file. In addition, the format of the configuration file is more intuitive than before.</p> <p>Because a single Connection Manager instance supports multiple connection units, you should configure backup Connection Manager instances in case the primary instance fails.</p>	<p>Chapter 11, "The oncmsm utility," on page 11-1</p>

The following table lists the new features for Version 11.70.xC2.

Table 4. What's New in IBM Informix Administrator's Reference for Version 11.70.xC2

Overview	Reference
<p>Improve network connection performance and scalability</p> <p>You can improve the performance and scalability of network connections on UNIX operating systems by using the NUMFDSEVERERS configuration parameter. Use the configuration parameter to adjust the maximum number of poll threads for the server to use when migrating TCP/IP connection across virtual processors (VPs). Adjusting the number of poll threads, for example, by increasing the number of poll threads beyond the default number, is useful if the database server has a high rate of new connect and disconnect requests or if you find a high amount of contention between network shared file (NSF) locks. For example, if you have multiple CPU VPs and poll threads and this results in NSF locking, you can increase the value of NUMFDSEVERERS (and you can increase the number of poll threads specified in the NETTYPE configuration parameter) to reduce NSF lock contention.</p>	<p>"NUMFDSEVERERS configuration parameter" on page 1-106</p>

Table 4. What's New in IBM Informix Administrator's Reference for Version 11.70.xC2 (continued)

Overview	Reference
<p>New SQL administration API arguments</p> <p>The following new arguments are available with the SQL admin API task() and admin() functions:</p> <ul style="list-style-type: none"> • create database: This argument creates a database and is equivalent to the CREATE DATABASE statement. • drop database: This argument drops a database and is equivalent to the DROP DATABASE statement. This function deletes the entire database, including all of the system catalog tables, objects, and data. • ontape archive: This argument invokes the ontape utility to create a backup. • onbar: This argument is equivalent to invoking specific options of the onbar utility to create backups. • onsmsync: This argument invokes the onsmsync utility to synchronize the sysutils database, the storage manager, and the emergency boot file. 	<p>“create database argument: Create a database (SQL administration API)” on page 22-31</p> <p>“drop database argument: Drop a database (SQL administration API)” on page 22-46</p> <p>“ontape archive argument: Backup the data on your database (SQL administration API)” on page 22-96</p> <p>“onbar argument: Backup the storage spaces (SQL administration API)” on page 22-93</p> <p>“onsmsync argument: Synchronize with the storage manager catalog (SQL administration API)” on page 22-95</p> <p>“print file info argument: Display directory or file information (SQL administration API)” on page 22-98</p>
<p>New event alarms</p> <p>Event alarm class IDs 81 and 83 were added.</p> <p>Event alarm 81 indicates logical log corruption. Event alarm 83 indicates that a shared disk secondary server could not become the primary server because the primary server was still active.</p>	<p>“Event alarm IDs” on page C-6</p>

The following table lists the new features for Version 11.70.xC1.

Table 5. What's New in IBM Informix Administrator's Reference for Version 11.70.xC1

Overview	Reference
<p>New SQLHOSTS parameter for Connection Manager</p> <p>You can set a new parameter named SQLHOSTS in the Connection Manager configuration file to specify how the Connection Manager searches for server instances that are requested by client connections. The SQLHOSTS option is useful when you want to allow user access or prevent user access to one or more servers in a high-availability cluster.</p>	<p>Chapter 11, “The oncmsm utility,” on page 11-1</p>
<p>Automating application connections to Enterprise Replication servers</p> <p>You can use the Connection Manager to direct application requests to the appropriate Enterprise Replication server. If you have created tables through a grid with replication enabled, you can route client connections to Enterprise Replication servers based on the quality of replicated data and transaction latency.</p>	<p>Chapter 11, “The oncmsm utility,” on page 11-1</p>

Table 5. What's New in IBM Informix Administrator's Reference for Version 11.70.xC1 (continued)

Overview	Reference
<p>Quickly clone a primary server</p> <p>You can now use the ifxclone utility to clone a primary server with minimal setup and configuration. Previously to clone a server it was necessary to create a level-0 backup, transfer the backup to the new system, restore the image, and initialize the instance. The ifxclone utility starts the backup and restore processes simultaneously and there is no need to read or write data to disk or tape. You can use the ifxclone utility to create a standalone server or a remote standalone secondary server. For example, you can quickly, easily, and securely clone a production system to a test system. The ifxclone utility requires the DIRECT_IO configuration parameter to be set to 0 on both the source and target servers.</p>	<p>Chapter 19, "The ifxclone utility," on page 19-1</p>
<p>Add a server to a replication domain by cloning</p> <p>You can add a replication server to an existing replication domain by using the ifxclone utility to clone an existing replication server onto a target database server.</p>	<p>Chapter 19, "The ifxclone utility," on page 19-1</p>
<p>Defragmenting partitions</p> <p>A frequently updated table can become fragmented over time and this fragmentation degrades performance when the table is accessed by the server. You can improve performance by defragmenting partitions to merge noncontiguous extents. Defragmenting a table brings data rows closer together and avoids partition header page overflow problems. Use the SQL administration API task() or admin() function with the defragment argument and specify the table name or partition number that you want to defragment.</p>	<p>"defragment argument: Dynamically defragment partition extents" on page 22-42</p> <p>"onstat -g defragment command: Print defragment partition extents" on page 21-75</p>
<p>Faster C user-defined routines</p> <p>You can improve the performance of C user-defined routines (UDRs) on UNIX, Linux, and Mac OS operating systems by loading the C UDR shared libraries when the database server is started. Otherwise, C UDR shared libraries are loaded when the libraries are first used. To preload a C UDR shared library, set the PRELOAD_DLL_FILE configuration parameter to the library path and file name. You must specify a separate PRELOAD_DLL_FILE configuration parameter for each library that you want to preload.</p>	<p>"PRELOAD_DLL_FILE Configuration Parameter" on page 1-115</p> <p>"onstat -g dll command: Print dynamic link library file list" on page 21-79</p>
<p>Monitoring high-availability servers</p> <p>You can now monitor the status of the primary server and all secondary servers in a high-availability cluster by using one command: onstat -g cluster. This command is an alternative to the individual commands: onstat -g dri, onstat -g sds, and onstat -g rss.</p>	<p>"onstat -g cluster command: Print high-availability cluster information" on page 21-65</p>
<p>Easier event alarm handling</p> <p>Event alarms now have a unique identification number for each specific message. You can write scripts to handle event alarms based on the unique identification number that corresponds to each specific message in an alarm class. Previously, event alarm handling scripts had to combine the class ID and the specific message.</p>	<p>"Event alarm IDs" on page C-6</p> <p>"Event Alarm Parameters" on page C-4</p>

Table 5. What's New in IBM Informix Administrator's Reference for Version 11.70.xC1 (continued)

Overview	Reference
<p>Fragment-level statistics</p> <p>In previous releases, for fragmented tables data distributions were calculated at table level to optimize query plans. This release supports a finer granularity of statistics for fragmented tables. The statistics are calculated and stored at the individual fragment level. Set the new STATLEVEL property of fragmented tables to specify whether TABLE or FRAGMENT is the granularity for data distributions, or set to AUTO to allow the database server to automatically choose the granularity of the distribution statistics for each fragmented table.</p>	<p>"AUTO_STAT_MODE configuration parameter" on page 1-32</p> <p>"STATCHANGE configuration parameter" on page 1-150</p>
<p>Compression functionality automatically enabled</p> <p>You can now compress data in a table or table fragment without first enabling compression. Previously you needed to run an SQL administration API command with the enable compression argument to enable the compression of data in a table or table fragment.</p>	<p>"Table and fragment compress and uncompress operations (SQL administration API)" on page 22-126</p>

Table 5. What's New in IBM Informix Administrator's Reference for Version 11.70.xC1 (continued)

Overview	Reference
<p>Automatic storage provisioning ensures space is available</p> <p>You can configure Informix to automatically expand an existing storage space if the space is full. You can also configure Informix to expand the space before it is full, when its free pages fall below a specified threshold. When you enable and configure automatic storage provisioning, you do not need to manually add storage space to avoid out-of-space errors. Even if you prefer to add space manually, automatic storage provisioning simplifies the process of adding space, because you do not need to determine where to get the space.</p> <p>You enable or disable the automatic expansion of storage spaces by setting the new SP_AUTOEXPAND configuration parameter.</p> <p>You can expand a storage space in one of two ways:</p> <ul style="list-style-type: none"> • Enable chunk extensions by marking specific chunks as extendable, using a new SQL administrative API command. • Enable automatic chunk creation by using another new SQL administrative API command to add valid entries to the Informix storage pool. Valid entries can include available directories, cooked files, and raw devices. <p>In addition, you can use new SQL administrative API commands to:</p> <ul style="list-style-type: none"> • Manually extend a chunk. • Modify the amount by which the data server can automatically expand a particular storage space. • Disable automatic expansion for a storage space. • Manually create storage spaces and chunks from the storage pool. • Return space to the storage pool, while dropping chunks and storage spaces. • Manage the storage pool by adding, modifying, and deleting entries. <p>Automatic storage provisioning is supported in a high-availability cluster. In this environment, any storage pool entry (directory, cooked file, or raw device) on the primary server must also be available through the same path on all secondary servers.</p>	<p>“SP_AUTOEXPAND configuration parameter” on page 1-143</p> <p>“SP_THRESHOLD configuration parameter” on page 1-143</p> <p>“SP_WAITTIME configuration parameter” on page 1-144</p> <p>“Storage Provisioning Arguments” in “SQL administration API portal: Arguments by functional category” on page 22-4</p> <p>“The storagepool table” on page 3-9</p>
<p>Improving performance by reducing buffer reads</p> <p>If you enable the new BATCHEDREAD_INDEX configuration parameter, the optimizer automatically chooses to fetch a set of keys from an index buffer, reducing the number of buffer times a buffer is read.</p>	<p>“BATCHEDREAD_INDEX configuration parameter” on page 1-33</p>

Table 5. What's New in IBM Informix Administrator's Reference for Version 11.70.xC1 (continued)

Overview	Reference
<p>Improve name service connection time</p> <p>You can use the new NS_CACHE configuration parameter to define the maximum retention time for an individual entry in the host name/IP address cache, the service cache, the user cache, and the group cache. If you disable one or more of these caches by setting the retention time to 0, the database server queries the operating system for the host, service, user, or group information. Getting information from the name service cache instead of querying the operating system decreases the amount of time needed to establish connections.</p> <p>The database server also now supports multiple listener threads for one service (port) for the onsoctcp and the onimcsoc protocols.</p>	<p>"NS_CACHE configuration parameter" on page 1-104</p>
<p>Improved return codes for the oninit utility</p> <p>The oninit utility now returns specific codes for failures during server initialization instead of returning a single code regardless of the cause.</p>	<p>"Return codes for the oninit utility" on page 13-4</p>
<p>ifxcollect tool for collecting data for specific problems</p> <p>You can use the new ifxcollect tool to collect diagnostic data if necessary for troubleshooting a specific problem, such as an assertion failure. The ifxcollect tool is in the \$INFORMIXDIR/bin directory. Output files that ifxcollect commands generate are in the \$INFORMIXDIR/isa/data directory.</p>	<p>"Collecting data with the ifxcollect tool" on page B-1</p>
<p>Prevent the accidental disk initialization of your instance or another instance</p> <p>You can use the new FULL_DISK_INIT configuration parameter to prevent the major problems that can occur if you or someone else accidentally initializes your instance or another instance when the first page of the first chunk (page zero) exists at the root path location. Page zero, which is created when Informix is initialized, is the system page that contains general information about the server.</p> <p>The FULL_DISK_INIT configuration parameter specifies whether or not the disk initialization command (oninit -i) can run on your Informix instance when a page zero exists at the root path location. When this configuration parameter is set to 0, the oninit -i command runs only if there is not a page zero at the root path location.</p> <p>If you change the setting of the FULL_DISK_INIT configuration parameter to 1, the oninit -i command runs under all circumstances, but also resets the FULL_DISK_INIT configuration parameter to 0 after the disk initialization.</p>	<p>"FULL_DISK_INIT Configuration Parameter" on page 1-81</p>
<p>New onconfig parameter to specify the default escape character</p> <p>The DEFAULTESCCHAR configuration parameter specifies the default escape character that is used.</p>	<p>"DEFAULTESCCHAR configuration parameter" on page 1-52</p>

Table 5. What's New in IBM Informix Administrator's Reference for Version 11.70.xC1 (continued)

Overview	Reference
<p>New editions and product names</p> <p>IBM Informix Dynamic Server editions were withdrawn and new Informix editions are available. Some products were also renamed. The publications in the Informix library pertain to the following products:</p> <ul style="list-style-type: none"> • IBM Informix database server, formerly known as IBM Informix Dynamic Server (IDS) • IBM OpenAdmin Tool (OAT) for Informix, formerly known as OpenAdmin Tool for Informix Dynamic Server (IDS) • IBM Informix SQL Warehousing Tool, formerly known as Informix Warehouse Feature 	<p>For more information about the Informix product family, go to http://www.ibm.com/software/data/informix/.</p>

Example code conventions

Examples of SQL code occur throughout this publication. Except as noted, the code is not specific to any single IBM Informix application development tool.

If only SQL statements are listed in the example, they are not delimited by semicolons. For instance, you might see the code in the following example:

```
CONNECT TO stores_demo
...

DELETE FROM customer
  WHERE customer_num = 121
...

COMMIT WORK
DISCONNECT CURRENT
```

To use this SQL code for a specific product, you must apply the syntax rules for that product. For example, if you are using an SQL API, you must use EXEC SQL at the start of each statement and a semicolon (or other appropriate delimiter) at the end of the statement. If you are using DB–Access, you must delimit multiple statements with semicolons.

Tip: Ellipsis points in a code example indicate that more code would be added in a full application, but it is not necessary to show it to describe the concept being discussed.

For detailed directions on using SQL statements for a particular application development tool or SQL API, see the documentation for your product.

Additional documentation

Documentation about this release of IBM Informix products is available in various formats.

You can access or install the product documentation from the Quick Start CD that is shipped with Informix products. To get the most current information, see the Informix information centers at [ibm.com](http://www.ibm.com)[®]. You can access the information centers and other Informix technical information such as technotes, white papers, and IBM Redbooks publications online at <http://www.ibm.com/software/data/sw-library/>.

Compliance with industry standards

IBM Informix products are compliant with various standards.

IBM Informix SQL-based products are fully compliant with SQL-92 Entry Level (published as ANSI X3.135-1992), which is identical to ISO 9075:1992. In addition, many features of IBM Informix database servers comply with the SQL-92 Intermediate and Full Level and X/Open SQL Common Applications Environment (CAE) standards.

The IBM Informix Geodetic DataBlade® Module supports a subset of the data types from the *Spatial Data Transfer Standard (SDTS)—Federal Information Processing Standard 173*, as referenced by the document *Content Standard for Geospatial Metadata*, Federal Geographic Data Committee, June 8, 1994 (FGDC Metadata Standard).

Syntax diagrams

Syntax diagrams use special components to describe the syntax for statements and commands.

Table 6. Syntax Diagram Components

Component represented in PDF	Component represented in HTML	Meaning
	>>-----	Statement begins.
	----->	Statement continues on next line.
	>-----	Statement continues from previous line.
	-----<<	Statement ends.
	-----SELECT-----	Required item.
	---+-----+--- '-----LOCAL-----'	Optional item.
	---+-----+--- +--DISTINCT-----+ '---UNIQUE-----'	Required item with choice. Only one item must be present.
	---+-----+--- +--FOR UPDATE-----+ '--FOR READ ONLY--'	Optional items with choice are shown below the main line, one of which you might specify.
	.---NEXT-----. ---+-----+--- +---PRIOR-----+ '---PREVIOUS-----'	The values below the main line are optional, one of which you might specify. If you do not specify an item, the value above the line is used by default.

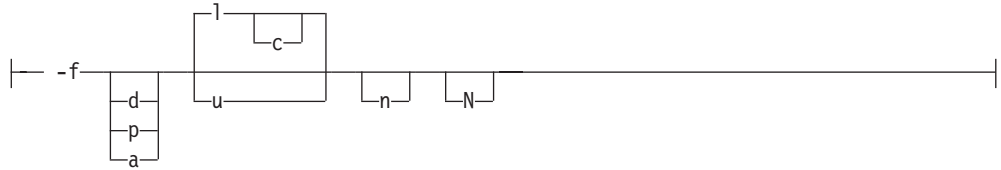

To see how to construct a command correctly, start at the upper left of the main diagram. Follow the diagram to the right, including the elements that you want. The elements in this diagram are case-sensitive because they illustrate utility syntax. Other types of syntax, such as SQL, are not case-sensitive.

The Creating a No-Conversion Job diagram illustrates the following steps:

1. Type **onpladm create job** and then the name of the job.
2. Optionally, type **-p** and then the name of the project.
3. Type the following required elements:
 - **-n**
 - **-d** and the name of the device
 - **-D** and the name of the database
 - **-t** and the name of the table
4. Optionally, you can choose one or more of the following elements and repeat them an arbitrary number of times:
 - **-S** and the server name
 - **-T** and the target server name
 - The run mode. To set the run mode, follow the Setting the Run Mode segment diagram to type **-f**, optionally type **d**, **p**, or **a**, and then optionally type **l** or **u**.
5. Follow the diagram to the terminator.

Keywords and punctuation

Keywords are words reserved for statements and all commands except system-level commands.

When a keyword appears in a syntax diagram, it is shown in uppercase letters. When you use a keyword in a command, you can write it in uppercase or lowercase letters, but you must spell the keyword exactly as it appears in the syntax diagram.

You must also use any punctuation in your statements and commands exactly as shown in the syntax diagrams.

Identifiers and names

Variables serve as placeholders for identifiers and names in the syntax diagrams and examples.

You can replace a variable with an arbitrary name, identifier, or literal, depending on the context. Variables are also used to represent complex syntax elements that are expanded in additional syntax diagrams. When a variable appears in a syntax diagram, an example, or text, it is shown in *lowercase italic*.

The following syntax diagram uses variables to illustrate the general form of a simple SELECT statement.

►—SELECT—*column_name*—FROM—*table_name*—◄

When you write a SELECT statement of this form, you replace the variables *column_name* and *table_name* with the name of a specific column and table.

How to provide documentation feedback

You are encouraged to send your comments about IBM Informix user documentation.

Use one of the following methods:

- Send email to docinf@us.ibm.com.
- In the Informix information center, which is available online at <http://www.ibm.com/software/data/sw-library/>, open the topic that you want to comment on. Click the feedback link at the bottom of the page, fill out the form, and submit your feedback.
- Add comments to topics directly in the information center and read comments that were added by other users. Share information about the product documentation, participate in discussions with other users, rate topics, and more!

Feedback from all methods is monitored by the team that maintains the user documentation. The feedback methods are reserved for reporting errors and omissions in the documentation. For immediate help with a technical problem, contact IBM Technical Support at <http://www.ibm.com/planetwide/>.

We appreciate your suggestions.

Part 1. Configuring and monitoring Informix

Chapter 1. Database configuration parameters

The Informix database server uses a configuration file called ONCONFIG. The ONCONFIG file contains default configuration parameter values. You can modify the parameter values to improve performance and other characteristics of the instance or database.

onconfig File Conventions

The ONCONFIG environment variable specifies the file that contains the configuration parameters. This file is also called the onconfig file. The database server uses the onconfig file during initialization.

In the onconfig file, each parameter is on a separate line. The file can also contain blank lines and comment lines that start with the # symbol. The maximum line limit of the onconfig file is 512 bytes. Lines that exceed this limit are truncated and might cause configuration problems.

The following line shows the syntax for a parameter line:

```
PARAMETER_NAME parameter_value comments
```

Any characters after the parameter value and blank space are interpreted as comments, regardless of whether they are preceded by a # symbol.

The parameter description and the possible values are specified in the comments above their entries in the onconfig.std file.

Parameters and their values in the onconfig file are case sensitive. The parameter names are always uppercase. If the value entry is described with uppercase letters, you must use uppercase (for example, the CPU value of the NETTYPE parameter). You must put white space (tabs, spaces, or both) between the parameter name, parameter value, and optional comment. Do not use any tabs or spaces within a parameter value.

Unrecognized parameters are copied but ignored and no error is given.

Most parameters can have one valid entry. If more than one entry for these parameters exists in the onconfig file, the first entry is used. Some parameter, however, can have multiple entries, such as the DBSERVERALIASES configuration parameter.

Tip: If you use a utility like **grep** on the onconfig.std template file, specify the new line character, `^`, to return just the configuration parameter name and value. Without the new line character, the parameter description is also returned.

For example, the following command returns both the configuration parameter description and the value:

```
grep "MSGPATH" onconfig.std
# MSGPATH      - The path of the IDS message log file
MSGPATH $INFORMIXDIR/tmp/online.log
```

Whereas, the following command returns only the configuration parameter value:

```
grep "^MSGPATH" onconfig.std
MSGPATH $INFORMIXDIR/tmp/online.log
```

Creating the onconfig File

You can use the `onconfig.std` template file to create the configuration file that you need for the database server.

The database server includes a template for a configuration file that contains initial values for many of the `onconfig` parameters.

The IBM Informix includes the `onconfig.std` template file, as a template configuration file that you can copy and tailor to your specific configuration.

Do not modify or delete `onconfig.std` template file. This file is a template and not a functional configuration.

Important: If you omit a parameter value in your copy of the configuration file, the database server either uses default values in `onconfig.std` template file or calculates values based on other parameter values.

To create the `onconfig` file:

1. Copy the `onconfig.std` template file to the proper location for the `onconfig` file on your database server. Use the following table to determine the locations for these files.

File	Location
<code>onconfig.std</code> template file	UNIX: <code>\$INFORMIXDIR/etc/onconfig.std</code> Windows: <code>%INFORMIXDIR%\etc\onconfig.std</code>
<code>onconfig</code> file	UNIX: <code>\$INFORMIXDIR/etc/\$ONCONFIG</code> Windows: <code>%INFORMIXDIR%\etc\%ONCONFIG%</code>

2. Rename the copy that you made of the `onconfig.std` template file.
3. Optional. Print out a copy of the `onconfig.std` file to see the latest default values for the configuration parameters and recommended settings.
4. Open the `onconfig` file and make any changes to the configuration parameters that you need to make. For more details on why you might want to modify the default configuration parameters, see configuring the database server.
5. Set the `ONCONFIG` environment variable to the name of the `onconfig` file. If you do not set the environment variable, the default file name is `onconfig`.

Related reference:

 Initialization process (Administrator's Guide)

Displaying the Settings in the onconfig File

There are several tools that you can use to display the settings in the `onconfig` file.

To display the settings in the `onconfig` file, use one of the following tools:

- A text editor.
- The `onstat -c` command. For more information, see “`onstat -c` command: Print `ONCONFIG` file contents” on page 21-28.

Related reference:

 [ONCONFIG environment variable \(SQL Reference\)](#)

onconfig Portal: Configuration parameters by functional category

The information in this section lists configuration parameters as they are in the `onconfig.std` file.

Category list

To use this section, you first determine the appropriate category from the following list, then follow the link to the configuration parameters for that category. The categories are listed in the same order as they are in the `onconfig.std` file. Parameters that are not in the `onconfig.std` file but that you can add to your `onconfig` file are listed in Table 1-53 on page 1-23.

- “Root dbspace configuration parameters” on page 1-4
- “Physical log configuration parameters” on page 1-5
- “Logical log configuration parameters” on page 1-5
- “Long transaction rollback configuration parameters” on page 1-5
- “Server message file configuration parameters” on page 1-5
- “Tbldspace tblspace in the root dbspace configuration parameters” on page 1-6
- “Temporary dbspace and sbspace configuration parameters” on page 1-6
- “Dbspace and sbspace configuration parameters” on page 1-6
- “Server instance configuration parameters” on page 1-7
- “Network configuration parameters” on page 1-7
- “CPU and virtual processors configuration parameters” on page 1-7
- “AIO and buffer cleaner configuration parameters” on page 1-8
- “Locking configuration parameters” on page 1-8
- “Shared memory configuration parameters” on page 1-8
- “Checkpoint and system block configuration parameters” on page 1-9
- “Conversion guard configuration parameters” on page 1-9
- “Distributed transactions configuration parameters” on page 1-10
- “Tape device configuration parameters” on page 1-10
- “Logical log tape device configuration parameters” on page 1-10
- “Backup and restore configuration parameters” on page 1-11
- “Informix Storage Manager configuration parameters” on page 1-11
- “Data dictionary cache configuration parameters” on page 1-12
- “Data distribution configuration parameters” on page 1-12
- “User defined routine (UDR) configuration parameters” on page 1-12
- “SQL statement cache configuration parameters” on page 1-12
- “Operating system and session configuration parameters” on page 1-13
- “Index configuration parameters” on page 1-13
- “Parallel database queries configuration parameters” on page 1-14
- “Optimizer configuration parameters” on page 1-14
- “Scan configuration parameters” on page 1-15
- “SQL tracing configuration parameters” on page 1-15
- “Security configuration parameters” on page 1-15

- “Label-based access control configuration parameters” on page 1-16
- “Optical Storage subsystem configuration parameters” on page 1-16
- “Built-in character data types configuration parameters” on page 1-17
- “Sequence cache configuration parameters” on page 1-17
- “High-availability and Enterprise Replication security configuration parameters” on page 1-17
- “Enterprise Replication configuration parameters” on page 1-18
- “High-availability cluster configuration parameters” on page 1-18
- “Logical recovery threads configuration parameters” on page 1-20
- “Diagnostic configuration parameters” on page 1-20
- “Alarm program configuration parameters” on page 1-20
- “Technical support configuration parameters” on page 1-21
- “Character processing configuration parameter” on page 1-21
- “Queue and wait statistics configuration parameters” on page 1-21
- “Low memory configuration parameters” on page 1-21
- “Java configuration parameters” on page 1-21
- “Buffer pool and LRU tuning configuration parameters” on page 1-22
- “Storage provisioning configuration parameters” on page 1-22
- “MQ messaging configuration parameters” on page 1-22

Root dbspace configuration parameters

Use the following configuration parameters to configure the root dbspace.

Table 1-1. Root dbspace configuration parameters

Configuration Parameter	Reference
“ROOTNAME Configuration Parameter” on page 1-122	The root dbspace name.
“ROOTPATH Configuration Parameter” on page 1-122	The path for the root dbspace.
“ROOTOFFSET Configuration Parameter” on page 1-122	The offset for the root dbspace.
“ROOTSIZE configuration parameter” on page 1-123	The size of the root dbspace.
“MIRROR Configuration Parameter” on page 1-98	Enables or disables mirroring.
“MIRRORPATH configuration parameter” on page 1-98	The path for the mirrored root dbspace.
“MIRROROFFSET Configuration Parameter” on page 1-98	The offset for the mirrored root dbspace.

Physical log configuration parameters

Use the following configuration parameters to configure physical logs.

Table 1-2. Physical log configuration parameters

Configuration Parameter	Reference
"PHYSFILE Configuration Parameter" on page 1-113	The size of the physical log.
"PLOG_OVERFLOW_PATH Configuration Parameter" on page 1-114	The overflow directory for physical log files.
"PHYSBUFF Configuration Parameter" on page 1-113	The size of the physical log buffer.

Logical log configuration parameters

Use the following configuration parameters to configure logical logs.

Table 1-3. Logical log configuration parameters

Configuration Parameter	Reference
"LOGFILES configuration parameter" on page 1-88	The number of logical log files.
"LOGSIZE configuration parameter" on page 1-90	The size of each logical log file.
"DYNAMIC_LOGS configuration parameter" on page 1-69	The type of dynamic log allocation.
"LOGBUFF configuration parameter" on page 1-87	The size of the logical log buffer.

Long transaction rollback configuration parameters

Use the following configuration parameters to control when long transactions are rolled back.

Table 1-4. Long transaction rollback configuration parameters

Configuration Parameter	Reference
"LTXHWM configuration parameter" on page 1-94	The percentage of the logical log files that can be filled before a long transaction is rolled back.
"LTXEHWM configuration parameter" on page 1-93	The percentage of the logical log files that can be filled before the server suspends other activities so that a long transaction has exclusive use of the logs.

Server message file configuration parameters

Use the following configuration parameters to configure the server message file.

Table 1-5. Server message file configuration parameters

Configuration Parameter	Reference
"MSGPATH configuration parameter" on page 1-100	The path of the message file.

Table 1-5. Server message file configuration parameters (continued)

Configuration Parameter	Reference
“CONSOLE configuration parameter” on page 1-41	The path of the console message file.

Tblspace tblspace in the root dbspace configuration parameters

Use the following configuration parameters to the tblspace **tblspace** in the root dbspace.

Table 1-6. Tblspace tblspace in the root dbspace configuration parameters

Configuration Parameter	Reference
“TBLTBLFIRST configuration parameter” on page 1-159	The first extent size for the tblspace tblspace .
“TBLTBLNEXT configuration parameter” on page 1-159	The next extent size for the tblspace tblspace .
“TBLSPACE_STATS configuration parameter” on page 1-158	Enables or disables tblspace statistics.

Temporary dbspace and sbspace configuration parameters

Use the following configuration parameters to configure the default temporary dbspaces and sbspaces.

Table 1-7. Temporary dbspace and sbspace configuration parameters

Configuration Parameter	Reference
“DBSPACETEMP configuration parameter” on page 1-47	The list of dbspaces for temporary objects.
“SBSPACETEMP configuration parameter” on page 1-128	The list of sbspaces for temporary smart large objects.

Dbspace and sbspace configuration parameters

Use the following configuration parameters to configure the default dbspaces and sbspaces.

Table 1-8. Default dbspaces and sbspaces configuration parameters

Configuration Parameter	Reference
“SBSPACENAME configuration parameter” on page 1-127	The default sbspace to store smart large objects.
“SYSSBSPACENAME configuration parameter” on page 1-157	The default sbspace for system statistics.
“ONDBSPACEDOWN configuration parameter” on page 1-108	Specifies the behavior of the server when a dbspace is down.

Server instance configuration parameters

Use the following configuration parameters to set server instance information.

Table 1-9. Server instance configuration parameters

Configuration Parameter	Reference
“SERVERNUM configuration parameter” on page 1-134	The unique ID for the database server instance.
“DBSERVERNAME configuration parameter” on page 1-46	The name of the default database server.
“DBSERVERALIASES configuration parameter” on page 1-44	List of alternative database server names.
“FULL_DISK_INIT Configuration Parameter” on page 1-81	Prevents an accidental disk reinitialization of an existing server instance.

Network configuration parameters

Use the following configuration parameters to configure the network.

Table 1-10. Network configuration parameters

Configuration Parameter	Reference
“NETTYPE Configuration Parameter” on page 1-101	The configuration of poll threads for a specific protocol.
“LISTEN_TIMEOUT configuration parameter” on page 1-86	The time the database server waits for a connection.
“MAX_INCOMPLETE_CONNECTIONS configuration parameter” on page 1-96	The maximum number of incomplete connections.
“FASTPOLL Configuration Parameter” on page 1-80	Enables or disables fast polling.
“NUMFDSERVERS configuration parameter” on page 1-106	For network connections on UNIX, use the NUMFDSERVERS configuration parameter to specify the maximum number of poll threads to handle network connections that are moving between VPs.
“NS_CACHE configuration parameter” on page 1-104	Defines the maximum retention time for an individual entry in the host name/IP address cache, the service cache, the user cache, and the group cache.

CPU and virtual processors configuration parameters

Use the following configuration parameters to configure CPU virtual processors.

Table 1-11. CPU virtual processors configuration parameters

Configuration Parameter	Reference
“MULTIPROCESSOR Configuration Parameter” on page 1-100	Specifies whether the computer has multiple CPUs.

Table 1-11. CPU virtual processors configuration parameters (continued)

Configuration Parameter	Reference
“VPCLASS configuration parameter” on page 1-167	Configures the CPU virtual processors.
“VP_MEMORY_CACHE_KB configuration parameter” on page 1-166	The amount of private memory blocks for the CPU virtual processors.
“SINGLE_CPU_VP configuration parameter” on page 1-141	Optimizes performance when there is a single CPU virtual processor.

AIO and buffer cleaner configuration parameters

Use the following configuration parameters to configure AIO virtual processors and buffer cleaners.

Table 1-12. AIO and buffer cleaner configuration parameters

Configuration Parameter	Reference
“VPCLASS configuration parameter” on page 1-167	Configures the AIO virtual processors.
“CLEANERS Configuration Parameter” on page 1-41	The number of page cleaner threads.
“AUTO_AIOVPS Configuration Parameter” on page 1-28	Enables or disables automatic management of AIO virtual processors.
“DIRECT_IO Configuration Parameter (UNIX)” on page 1-53	Specifies whether to use direct I/O.

Locking configuration parameters

Use the following configuration parameters to set locking behavior.

Table 1-13. Locking configuration parameters

Configuration Parameter	Reference
“LOCKS Configuration Parameter” on page 1-86	The initial number of locks at startup.
“DEF_TABLE_LOCKMODE configuration parameter” on page 1-51	The default table lock mode.

Shared memory configuration parameters

Use the following configuration parameters to configure shared memory.

Table 1-14. Shared memory configuration parameters

Configuration Parameter	Reference
“RESIDENT configuration parameter” on page 1-119	Controls whether shared memory is resident.

Table 1-14. Shared memory configuration parameters (continued)

Configuration Parameter	Reference
“SHMBASE Configuration Parameter” on page 1-136	The shared memory base address. Do not change this value.
“SHMVIRT_SIZE configuration parameter” on page 1-139	The initial size, in KB, of the virtual segment of shared memory.
“SHMADD configuration parameter” on page 1-135	The size of virtual shared memory segments.
“EXTSHMADD configuration parameter” on page 1-78	The size of each virtual-extension shared memory segment for user-defined routines and DataBlade routines that run in user-defined virtual processors.
“SHMTOTAL configuration parameter” on page 1-137	The maximum amount of shared memory for the database server.
“SHMVIRT_ALLOCSEG configuration parameter” on page 1-138	Controls when to add a memory segment.
“SHMNOACCESS Configuration Parameter” on page 1-136	Lists shared memory addresses that the server cannot access.

Checkpoint and system block configuration parameters

Use the following configuration parameters to configure checkpoints, recovery time objective, and system block time.

Table 1-15. Checkpoints, recovery time objective, and system block time configuration parameters

Configuration Parameter	Reference
“CKPTINTVL configuration parameter” on page 1-40	How often to check if a checkpoint is needed.
“AUTO_CKPTS configuration parameter” on page 1-29	Enables or disables automatic checkpoints.
“RTO_SERVER_RESTART configuration parameter” on page 1-125	The recovery time objective for a restart after a failure.
“BLOCKTIMEOUT configuration parameter” on page 1-34	The amount of time for a system block.

Conversion guard configuration parameters

Use the following configuration parameters to control information Informix uses during an upgrade to a new version of the server.

Table 1-16. Conversion guard configuration parameters

Configuration Parameter	Reference
“CONVERSION_GUARD configuration parameter” on page 1-41	Specifies whether to stop or continue an upgrade if an error occurs during the upgrade.

Table 1-16. Conversion guard configuration parameters (continued)

Configuration Parameter	Reference
“RESTORE_POINT_DIR configuration parameter” on page 1-121	Specifies where restore point files are placed during a failed upgrade when the CONVERSION_GUARD configuration parameter is enabled.

Distributed transactions configuration parameters

Use the following configuration parameters to control distributed transactions.

Table 1-17. Distributed transaction configuration parameters

Configuration Parameter	Reference
“TXTIMEOUT configuration parameter” on page 1-161	The distributed transaction timeout period.
“DEADLOCK_TIMEOUT configuration parameter” on page 1-50	The maximum amount of time to wait for a lock in a distributed transaction.
“HETERO_COMMIT Configuration Parameter” on page 1-83	Enables or disables heterogeneous commits for transactions using an EGM gateway.

Tape device configuration parameters

Use the following configuration parameters to configure the tape device for backups with the **ontape** utility.

Table 1-18. Tape device configuration parameters

Configuration Parameter	Reference
TAPEDEV configuration parameter	The tape device for backups.
TAPEBLK configuration parameter	The tape block size.
TAPESIZE configuration parameter	The maximum amount of data to put on one backup tape.

Logical log tape device configuration parameters

Use the following configuration parameters to configure the tape device for logical logs with the **ontape** utility.

Table 1-19. Logical log tape device configuration parameters

Configuration Parameter	Reference
LTAPEDEV configuration parameter	The tape device for logical log backups.
LTAPEBLK configuration parameter	The tape block size for logical log backups.
LTAPESIZE configuration parameter	The maximum amount of data to put on one logical log backup tape.

Backup and restore configuration parameters

Use the following configuration parameters to control backup and restore with the ON-Bar utility. Unless specified otherwise, these configuration parameters are documented in the *IBM Informix Backup and Restore Guide*.

Table 1-20. ON-Bar configuration parameters

Configuration Parameter	Reference
BAR_ACT_LOG configuration parameter	The location of the ON-Bar activity log file.
BAR_DEBUG_LOG configuration parameter	The location of the ON-Bar debug log file.
BAR_DEBUG configuration parameter	The debug level for ON-Bar.
BAR_MAX_BACKUP configuration parameter	The number of backup threads used in a backup.
BAR_RETRY configuration parameter	The number of times to try a backup or restore again.
BAR_NB_XPORT_COUNT configuration parameter	The number of data buffers each backup process uses.
BAR_XFER_BUF_SIZE configuration parameter	The size of each data buffer.
RESTARTABLE_RESTORE configuration parameter	Enables ON-Bar to continue a backup after a failure.
BAR_PROGRESS_FREQ configuration parameter	How often progress messages are put in the activity log.
BAR_BSAIB_PATH configuration parameter	The path for the shared library for ON-Bar and the storage manager.
BACKUP_FILTER configuration parameter	The path of a filter program to use during backups.
RESTORE_FILTER configuration parameter	The path of a filter program to use during restores.
BAR_PERFORMANCE configuration parameter	The type of ON-Bar performance statistics to report.
BAR_CKPTSEC_TIMEOUT configuration parameter	Time in seconds to wait for an archive checkpoint to complete in the secondary server.

Informix Storage Manager configuration parameters

Use the following configuration parameters to configure the Informix Storage Manager (ISM). These configuration parameters are documented in the *IBM Informix Storage Manager Administrator's Guide*.

Table 1-21. Informix Storage Manager configuration parameters

Configuration Parameter	Reference
ISM_DATA_POOL configuration parameter	The name of the ISM data pool.
ISM_LOG_POOL configuration parameter	The name of the ISM log pool.

Data dictionary cache configuration parameters

Use the following configuration parameters to configure the data dictionary caches.

Table 1-22. Data dictionary cache configuration parameters

Configuration Parameter	Reference
“DD_HASHSIZE Configuration Parameter” on page 1-50	The number of data dictionary pools.
“DD_HASHMAX configuration parameter” on page 1-50	The number of entries per pool.

Data distribution configuration parameters

Use the following configuration parameters to configure the data distribution pools.

Table 1-23. Data distribution configuration parameters

Configuration Parameter	Reference
“DS_HASHSIZE Configuration Parameter” on page 1-60	The number of data distribution pools.
“DS_POOLSIZ Configuration Parameter” on page 1-64	The maximum number of entries in the data distribution cache.

User defined routine (UDR) configuration parameters

Use the following configuration parameters to configure UDRs.

Table 1-24. UDR configuration parameters

Configuration Parameter	Reference
“PC_HASHSIZE Configuration Parameter” on page 1-112	The number of hash buckets in the UDR cache.
“PC_POOLSIZ Configuration Parameter” on page 1-112	The maximum number of entries in the UDR cache.
“PRELOAD_DLL_FILE Configuration Parameter” on page 1-115	The C UDR shared library path name to load when the server starts.

SQL statement cache configuration parameters

Use the following configuration parameters to configure the SQL statement cache.

Table 1-25. SQL statement cache configuration parameters

Configuration Parameter	Reference
“STMT_CACHE Configuration Parameter” on page 1-151	Controls SQL statement caching.

Table 1-25. SQL statement cache configuration parameters (continued)

Configuration Parameter	Reference
“STMT_CACHE_HITS Configuration Parameter” on page 1-152	The number of times an SQL statement is run before it is cached.
“STMT_CACHE_SIZE Configuration Parameter” on page 1-153	The size of the SQL statement cache.
“STMT_CACHE_NOLIMIT Configuration Parameter” on page 1-152	Controls additional memory consumption of the SQL statement cache.
“STMT_CACHE_NUMPOOL Configuration Parameter” on page 1-153	The number of pools for the SQL statement cache.

Operating system and session configuration parameters

Use the following configuration parameters to configure operating system and session features.

Table 1-26. Operating system and session configuration parameters

Configuration Parameter	Reference
“USEOSTIME Configuration Parameter” on page 1-164	The precision of SQL statement timing.
“STACKSIZE configuration parameter” on page 1-149	The size of a session stack.
“ALLOW_NEWLINE Configuration Parameter” on page 1-27	Whether embedded new line characters are allowed in SQL statements.
“USELASTCOMMITTED configuration parameter” on page 1-162	Controls committed read isolation level.

Index configuration parameters

Use the following configuration parameters to configure index features.

Table 1-27. Index configuration parameters

Configuration Parameter	Reference
“FILLFACTOR configuration parameter” on page 1-81	The percentage of index page fullness.
“MAX_FILL_DATA_PAGES Configuration Parameter” on page 1-95	Enables or disables filling data pages as full as possible if they have variable length rows.
“BTSCANNER Configuration Parameter” on page 1-34	Configures B-tree scanner threads.
“ONLIDX_MAXMEM configuration parameter” on page 1-109	The amount of memory for the pre-image and updator log pools.

Parallel database queries configuration parameters

Use the following configuration parameters to configure parallel database queries (PDQ).

Table 1-28. PDQ configuration parameters

Configuration Parameter	Reference
"MAX_PDQPRIORITY configuration parameter" on page 1-96	The maximum percentage of resources for a single query.
"DS_MAX_QUERIES configuration parameter" on page 1-61	The maximum number of concurrent decision support queries.
"DS_TOTAL_MEMORY configuration parameter" on page 1-64	The maximum amount of decision support memory.
"DS_MAX_SCANS configuration parameter" on page 1-62	The maximum number of decision support scans.
"DS_NONPDQ_QUERY_MEM configuration parameter" on page 1-63	The amount of non-PDQ query memory.
"DATASKIP Configuration Parameter" on page 1-42	Whether to skip a dbspace when processing a query.

Optimizer configuration parameters

Use the following configuration parameters to influence query execution optimizer plans and directives.

Table 1-29. Optimizer configuration parameters

Configuration Parameter	Reference
"OPTCOMPIND configuration parameter" on page 1-110	Controls how the optimizer determines the best query path.
"DIRECTIVES configuration parameter" on page 1-55	Enables or disables inline optimizer directives.
"EXT_DIRECTIVES Configuration Parameter" on page 1-77	Enables or disables external directives.
"OPT_GOAL Configuration Parameter" on page 1-111	Controls how to optimize for fastest retrieval.
"IFX_FOLDVIEW configuration parameter" on page 1-84	Enables or disables folding views.
"AUTO_REPREPARE configuration parameter" on page 1-31	Enables or disables automatically reoptimizing stored procedures and reparing prepared statements.
"AUTO_STAT_MODE configuration parameter" on page 1-32	Enables or disables the mode for selectively updating statistics for your system.

Table 1-29. Optimizer configuration parameters (continued)

Configuration Parameter	Reference
“STATCHANGE configuration parameter” on page 1-150	Specifies a positive integer for a global percentage of a change threshold to identify data distribution statistics that need to be updated.
“USTLOW_SAMPLE configuration parameter” on page 1-166	Enables or disables the generation of index statistics based on sampling when you run UPDATE STATISTICS statements in LOW mode.

Scan configuration parameters

Use the following configuration parameters to set read-ahead behavior.

Table 1-30. Scan configuration parameters

Configuration Parameter	Reference
“RA_PAGES configuration parameter” on page 1-116	The number of pages to read ahead.
“BATCHEDREAD_TABLE configuration parameter” on page 1-33	Enables or disables light scans on compressed tables, tables with rows that are larger than a page, and tables with VARCHAR, LVARCHAR, and NVARCHAR data.
“BATCHEDREAD_INDEX configuration parameter” on page 1-33	Enables the optimizer to automatically fetch a set of keys from an index buffer.
“AUTO_READAHEAD configuration parameter” on page 1-30	Changes the automatic read-ahead mode or disables or enables automatic read ahead for a query.

SQL tracing configuration parameters

Use the following configuration parameters to set SQL tracing.

Table 1-31. SQL tracing configuration parameters

Configuration Parameter	Reference
“EXPLAIN_STAT Configuration Parameter” on page 1-76	Enables or disables including query statistics in the EXPLAIN output file.
“SQLTRACE Configuration Parameter” on page 1-147	Configures SQL tracing.

Security configuration parameters

Use the following configuration parameters to configure security options.

Table 1-32. Security configuration parameters

Configuration Parameter	Reference
“DBCREATE_PERMISSION Configuration Parameter” on page 1-43	Specifies users who can create databases.
“DB_LIBRARY_PATH Configuration Parameter” on page 1-44	Specifies the locations of UDR or UDT shared libraries.
“GSKIT_VERSION configuration parameter” on page 1-82	Specifies which version of IBM Global Security Kit the database server uses.

Table 1-32. Security configuration parameters (continued)

Configuration Parameter	Reference
“IFX_EXTEND_ROLE configuration parameter” on page 1-83	Controls how to specify which users can register external routines.
“SECURITY_LOCALCONNECTION Configuration Parameter” on page 1-133	Whether the database server checks the security of local connections.
“UNSECURE_ONSTAT Configuration Parameter” on page 1-161	Whether non-DBSA users can run onstat commands.
“ADMIN_USER_MODE_WITH_DBSA Configuration Parameter” on page 1-25	Controls who can connect to the server in administration mode.
“ADMIN_MODE_USERS configuration parameter” on page 1-24	Lists the users who can connect in administration mode.
“SSL_KEYSTORE_LABEL configuration parameter” on page 1-148	The SSL label.
“USERMAPPING configuration parameter (UNIX, Linux)” on page 1-165	Whether mapped users can connect to Informix, and if so, whether the mapped user can have administrative privileges.

Label-based access control configuration parameters

Use the following configuration parameters to configure the label-based access control (LBAC) cache. These configuration parameters are documented in the *IBM Informix Security Guide*.

Table 1-33. LBAC configuration parameters

Configuration Parameter	Reference
PLCY_HASHSIZE	The maximum number of entries in each hash bucket of the LBAC security information cache.
PLCY_POOLSIZE	The number of hash buckets in the LBAC security information cache.
USRC_HASHSIZE	The maximum number of entries in each hash bucket of the LBAC credential memory cache.
USRC_POOLSIZE	The number of hash buckets in the LBAC credential memory cache.

Optical Storage subsystem configuration parameters

Use the following configuration parameters to configure the optical storage subsystem.

Table 1-34. Optical storage subsystem configuration parameters

Configuration Parameter	Reference
“STAGEBLOB Configuration Parameter” on page 1-150	The name of the optical blob space.
“OPCACHEMAX Configuration Parameter (UNIX)” on page 1-109	The maximum size of the optical cache.

Built-in character data types configuration parameters

Use the following configuration parameter to configure built-in character data types.

Table 1-35. Built-in character data types configuration parameters

Configuration Parameter	Reference
“SQL_LOGICAL_CHAR configuration parameter” on page 1-145	Enables or disables the expansion of size specifications in declarations of built-in character data types.

Sequence cache configuration parameters

Use the following configuration parameter to configure the sequence cache:

Table 1-36. Sequence cache data types configuration parameters

Configuration Parameter	Reference
“SEQ_CACHE_SIZE configuration parameter” on page 1-134	Specifies the maximum number of sequence objects that can have preallocated values in the sequence cache.

High-availability and Enterprise Replication security configuration parameters

Use the following configuration parameters to configure security for high-availability clusters and Enterprise Replication.

Table 1-37. High-availability and Enterprise Replication security configuration parameters

Configuration Parameter	Reference
“ENCRYPT_HDR Configuration Parameter” on page 1-73	Enables or disables encryption for HDR.
“ENCRYPT_SMX Configuration Parameter” on page 1-75	The level of encryption for SDS or RSS servers.
ENCRYPT_CDR configuration parameter	The level of encryption for Enterprise Replication.
“ENCRYPT_CIPHERS Configuration Parameter” on page 1-71	Lists encryption ciphers and modes.
“ENCRYPT_MAC Configuration Parameter” on page 1-73	The level of the message authentication code (MAC).
“ENCRYPT_MACFILE configuration parameter” on page 1-74	The paths of MAC key files.
“ENCRYPT_SWITCH configuration parameter” on page 1-76	The frequency to switch ciphers and keys.

Enterprise Replication configuration parameters

Use the following configuration parameters to configure Enterprise Replication. These configuration parameters are documented in the *IBM Informix Enterprise Replication Guide*.

Table 1-38. Enterprise Replication configuration parameters

Configuration Parameter	Reference
CDR_EVALTHREADS configuration parameter	The numbers of evaluator threads.
CDR_DSLOCKWAIT configuration parameter	The amount of time data sync threads wait for database locks.
CDR_QUEUEMEM configuration parameter	The maximum amount of memory for send and receive queues.
CDR_NIFCOMPRESS configuration parameter	The network interface compression level.
CDR_SERIAL configuration parameter	The incremental size and starting value of serial columns.
CDR_DBSPACE configuration parameter	The dbspace name for the syscdr database.
CDR_QDATA_SBSpace configuration parameter	The names of sbspaces for spooled transactions.
CDR_SUPPRESS_ATSRISWARN configuration parameter	The data sync warnings and errors to suppress in ATS and RIS files.
CDR_DELAY_PURGE_DTC configuration parameter	The amount of time to retain delete tables.
CDR_LOG_LAG_ACTION configuration parameter	The action taken when the database server comes close to overwriting a logical log that Enterprise Replication did not yet process.
CDR_LOG_STAGING_MAXSIZE configuration parameter	The maximum amount of space that Enterprise Replication uses to stage log files.
CDR_MAX_DYNAMIC_LOGS configuration parameter	The maximum number of dynamic log requests that Enterprise Replication can make in a session.

High-availability cluster configuration parameters

Use the following configuration parameters to configure high-availability clusters.

Table 1-39. High-availability cluster configuration parameters

Configuration Parameter	Reference
“DRAUTO configuration parameter” on page 1-57	Controls automatic failover of primary servers.
“DRINTERVAL configuration parameter” on page 1-58	The maximum interval between buffer flushes.
“DRTIMEOUT configuration parameter” on page 1-59	The network timeout period.
“DRLOSTFOUND Configuration Parameter” on page 1-59	The path of the HDR lost-and-found file.
“DRIDXAUTO Configuration Parameter” on page 1-58	Enables or disables automatic index repair.

Table 1-39. High-availability cluster configuration parameters (continued)

Configuration Parameter	Reference
“HA_ALIAS configuration parameter” on page 1-82	The server alias for a high-availability cluster.
“LOG_INDEX_BUILDS Configuration Parameter” on page 1-89	Enables or disables index page logging.
“SDS_ENABLE Configuration Parameter” on page 1-129	Enables or disables and SD secondary server.
“SDS_LOGCHECK configuration parameter” on page 1-130	Whether the primary server is generating log activity and to allow or prevent failover of the primary server.
“SDS_TIMEOUT configuration parameter” on page 1-133	The time the primary waits for acknowledgment from an SD secondary server.
“SDS_TEMPDBS Configuration Parameter” on page 1-131	The temporary dbspace used by an SD secondary server.
“SDS_PAGING Configuration Parameter” on page 1-131	The paths of SD secondary paging files.
“UPDATABLE_SECONDARY Configuration Parameter” on page 1-162	Whether the secondary server can accept update, insert, or delete operations from clients.
“FAILOVER_CALLBACK Configuration Parameter” on page 1-79	The program called when a secondary server makes the transition to a standard or primary server.
“TEMPTAB_NOLOG configuration parameter” on page 1-160	The default logging mode for temporary tables.
“DELAY_APPLY Configuration Parameter” on page 1-53	The delay time for applying transactions on an RS secondary server.
“STOP_APPLY configuration parameter” on page 1-154	Stops applying transactions on an RS secondary server.
“LOG_STAGING_DIR configuration parameter” on page 1-90	The directory to stage log files.
“RSS_FLOW_CONTROL Configuration Parameter” on page 1-123	Specifies the boundaries within which flow control is enabled.
“FAILOVER_TX_TIMEOUT configuration parameter” on page 1-79	Enables or disables transaction survival behavior during failover.
“ENABLE_SNAPSHOT_COPY configuration parameter” on page 1-71	Whether the server instance can be cloned by the ifxclone utility.
“SMX_COMPRESS configuration parameter” on page 1-142	The level of compression that the database server uses when sending data from the source database server to the target database server.

Logical recovery threads configuration parameters

Use the following configuration parameters to set logical recovery threads.

Table 1-40. Logical recovery threads configuration parameters

Configuration Parameter	Reference
"ON_RECVRY_THREADS Configuration Parameter" on page 1-107	The number of logical recovery threads that run in parallel during a warm restore.
"OFF_RECVRY_THREADS configuration parameter" on page 1-107	The number of logical recovery threads used in a cold restore or for fast recovery.

Diagnostic configuration parameters

Use the following configuration parameters to control diagnostic information.

Table 1-41. Diagnostic configuration parameters

Configuration Parameter	Reference
"DUMPPDIR Configuration Parameter" on page 1-67	The location of assertion failure diagnostic files.
"DUMPSHMEM configuration parameter (UNIX)" on page 1-68	Controls shared memory dumps.
"DUMPGCORE Configuration Parameter (UNIX)" on page 1-67	Enables or disables whether the database server dumps a core to the gcore file.
"DUMPCORE Configuration Parameter (UNIX)" on page 1-67	Enables or disables whether the database server dumps a core after an assertion failure.
"DUMPCNT configuration parameter (UNIX)" on page 1-66	The maximum number of shared memory dumps for a session.

Alarm program configuration parameters

Use the following configuration parameters to configure the alarm program.

Table 1-42. Alarm program configuration parameters

Configuration Parameter	Reference
"ALARMPROGRAM configuration parameter" on page 1-26	The alarm program to display event alarms.
"ALRM_ALL_EVENTS configuration parameter" on page 1-28	Whether the alarm program runs for all events.
"STORAGE_FULL_ALARM Configuration Parameter" on page 1-155	How often messages and events are raised when a storage space is full or a partition runs out of pages or extents.
"SYSALARMPROGRAM configuration parameter" on page 1-156	The system alarm program triggered after an assertion failure.

Technical support configuration parameters

The following configuration parameters to are used by technical support and are set automatically.

Table 1-43. Technical support configuration parameters

Configuration Parameter	Reference
RAS_PLOG_SPEED	Reserved for support.
RAS_LLOG_SPEED	Reserved for support.

Character processing configuration parameter

Use the following configuration parameter to control whether Informix checks if characters are valid for the locale.

Table 1-44. Character processing configuration parameter

Configuration Parameter	Reference
“EILSEQ_COMPAT_MODE configuration parameter” on page 1-70	Enables or disables checking character validity.

Queue and wait statistics configuration parameters

Use the following configuration parameters to control the collection of queue and wait statistics.

Table 1-45. Queue and wait statistics configuration parameters

Configuration Parameter	Reference
“QSTATS Configuration Parameter” on page 1-116	Enables or disables collecting queue statistics.
“WSTATS configuration parameter” on page 1-170	Enables or disables collecting wait statistics.

Low memory configuration parameters

Use the following configuration parameters to manage low memory.

Table 1-46. Low memory configuration parameters

Configuration Parameter	Reference
“LOW_MEMORY_RESERVE configuration parameter” on page 1-92	Reserves a specific amount of memory for use when critical activities are needed and the server has limited free memory.
“LOW_MEMORY_MGR configuration parameter” on page 1-91	Change the default behavior of the server when it reaches the memory limit.

Java configuration parameters

Use the following configuration parameters to configure Java virtual processors. These configuration parameters are documented in the *J/Foundation Developer's Guide*.

Table 1-47. Java configuration parameters

Configuration Parameter	Reference
VPCLASS	Configures Java virtual processors.
JVPPROFILE	The Java VP property file.
JVPLOGFILE	The Java VP log file.
JDKVERSION	The supported version of JDK.
JVPARGS	Configures the Java VM.
JVPCCLASSPATH	The Java class path.

Buffer pool and LRU tuning configuration parameters

Use the following configuration parameters to configure buffer pools and tune LRU queues.

Table 1-48. Buffer pool and LRU tuning configuration parameters

Configuration Parameter	Reference
"BUFFERPOOL configuration parameter" on page 1-36	Configures buffer pools:
"AUTO_LRU_TUNING configuration parameter" on page 1-29	Enables or disables automatic tuning of LRU queues:

Storage provisioning configuration parameters

Use the following configuration parameters to control information that enables the server to automatically extend or add a chunk when more space is needed in an existing storage space (dbspace, temporary dbspace, sbspace, temporary sbspace, or blobspace).

Table 1-49. Storage provisioning configuration parameters

Configuration Parameter	Reference
"SP_AUTOEXPAND configuration parameter" on page 1-143	Enables or disables the automatic creation or extension of chunks in a storage space:
"SP_THRESHOLD configuration parameter" on page 1-143	Defines the minimum amount of free KB that can exist in a storage space:
"SP_WAITTIME configuration parameter" on page 1-144	Specifies the maximum number of seconds that a thread waits for a storage pool to expand before returning an "out of space" error:

MQ messaging configuration parameters

Use the following configuration parameters to configure the database server for MQ messaging. These configuration parameters are documented in the *IBM Informix Database Extensions User's Guide*.

Table 1-50. MQ configuration parameters

Configuration Parameter	Reference
MQCHLLIB configuration parameter	Specifies the path to the directory that contains the IBM WebSphere® MQ client channel definition table:
MQCHLTAB configuration parameter	Specifies the name of IBM WebSphere the client channel definition table:
MQSERVER configuration parameter	Defines a channel, specifies the location of the IBM WebSphere MQ server, and specifies the communication method to be used:

Default Escape configuration parameter

Use the following configuration parameter as needed.

Table 1-51. Default escape configuration parameter

Configuration Parameter	Reference
“DEFAULTESCCHAR configuration parameter” on page 1-52	Specifies a default escape character:

Non-root user server installation

Use the following configuration parameters with non-root server installations.

Table 1-52. Non-root user server installation

Configuration Parameter	Reference
“REMOTE_SERVER_CFG configuration parameter” on page 1-117	Specifies the name of a file that lists the remote hosts that are trusted by the database server computer.
“REMOTE_USERS_CFG configuration parameter” on page 1-118	Specifies the name of a file that lists names of trusted users that exist on remote hosts.
“S6_USE_REMOTE_SERVER_CFG configuration parameter” on page 1-125	Specifies the file used to authenticate secure server connections in a trusted network environment.

Additional parameters

Some configuration parameters are not in the onconfig.std file but you can add them to your onconfig file as necessary.

Table 1-53. Parameters that you can add to an onconfig file

Configuration Parameter	Reference
CDR_APPLY configuration parameter	Specifies the minimum and maximum number of data sync threads.
CDR_ENV configuration parameter	
“CHECKALLOMANSFORUSER configuration parameter” on page 1-39	Specifies how the database server searches for user names in a networked Windows environment.

Table 1-53. Parameters that you can add to an onconfig file (continued)

Configuration Parameter	Reference
“DISABLE_B162428_XA_FIX Configuration Parameter” on page 1-55	Specifies whether to free global transactions after a rollback operation.
“DRDA_COMMBUFFSIZE Configuration Parameter” on page 1-56	Specifies the size of the DRDA® communications buffer.
“LIMITNUMSESSIONS configuration parameter” on page 1-85	Specifies the maximum number of sessions that can connect to the database server.
“MSG_DATE configuration parameter” on page 1-99	Inserts a date stamp at the beginning of messages printed to the online log.
“NET_IO_TIMEOUT_ALARM configuration parameter” on page 1-101	Sends notification if network write operations are blocked for 30 minutes or more.
“PN_STAGEBLOB_THRESHOLD configuration parameter” on page 1-114	Reserves space for BYTE and TEXT data in round-robin fragments.

Related reference:

“onconfig.std” on page A-8

ADMIN_MODE_USERS configuration parameter

The ADMIN_MODE_USERS configuration parameter specifies a list of users, besides the user **informix** and members of the DBSA group, that you want to access the database server in the administration mode.

onconfig.std *value*

None

range of values

Comma-separated user names, such as: Karin,Sarah,Andrew, as a string of up to 127 bytes

utilities

oninit -U, onmode -j -U

takes effect

After you edit your onconfig file and restart the database server.

When you reset the value dynamically in your onconfig file by running the **onmode -wf** command.

When you reset the value for a session by running the **onmode -wm** command.

Usage

The list of users in the ADMIN_MODE_USERS configuration parameter is preserved indefinitely. You can use the **onmode -wm** or **onmode -wf** command to remove users.

Use the **onmode -j -U** command to allow one or more users to access the database server in administration mode when the database is running.

You must set the ADMIN_USER_MODE_WITH_DBSA configuration parameter to 1 to enable the users that are listed in the ADMIN_MODE_USERS configuration parameter to connect to the database server in the administration mode.

Related reference:

“onmode -wf, -wm: Dynamically change certain configuration parameters” on page 15-26

“Changing the Database Server to Administration Mode with the -j Option” on page 15-18

“ADMIN_USER_MODE_WITH_DBSA Configuration Parameter”

Chapter 13, “The oninit utility,” on page 13-1

ADMIN_USER_MODE_WITH_DBSA Configuration Parameter

The ADMIN_USER_MODE_WITH_DBSA configuration parameter specifies which users, besides the user **informix**, can connect to the database server in the administration mode.

onconfig.std *value*

None

if not present

0

takes effect

When the database server is shut down and restarted

range of values

Value	Valid users who can connect in the administration mode
0	<ul style="list-style-type: none"> Only the user informix can connect in the administration mode
1	<p>If the ADMIN_USER_MODE configuration parameter is not set, the following users can connect in the administration mode:</p> <ul style="list-style-type: none"> The user informix Members of the DBSA group <p>If the ADMIN_USER_MODE configuration parameter is set to a list of one or more user names, then following users can connect in the administration mode:</p> <ul style="list-style-type: none"> The user informix The users who have the informix group included in their group list (UNIX only) Members of the DBSA group The administration users that are listed in the ADMIN_MODE_USERS configuration parameter

refer to “ADMIN_MODE_USERS configuration parameter” on page 1-24

Related reference:

“ADMIN_MODE_USERS configuration parameter” on page 1-24

ALARMPROGRAM configuration parameter

Use the ALARMPROGRAM configuration parameter to display event alarms.

onconfig.std *value*

On UNIX: `$INFORMIXDIR/etc/alarmprogram.sh`

On Windows: `%INFORMIXDIR%\etc\alarmprogram.bat`

if not present

On UNIX: `$INFORMIXDIR/etc/no_log.sh`

On Windows: `%INFORMIXDIR%\etc\no_log.bat`

range of values

Full pathname

takes effect

After you edit your onconfig file and restart the database server.

When you reset the value dynamically in your onconfig file by running the **onmode -wf** command.

When you reset the value for a session by running the **onmode -wm** command.

Usage

You can set the ALRM_ALL_EVENTS configuration parameter to specify whether the ALARMPROGRAM configuration parameter runs for all events that are logged in the MSGPATH, or only for specified noteworthy events (events greater than severity 1).

The following sample scripts are provided.

Table 1-54. Sample scripts

Script Name	Platform	Description
<code>log_full.sh</code>	UNIX	To back up logical logs automatically when the database server issues a log-full event alarm, set ALARMPROGRAM to <code>log_full.sh</code> or <code>log_full.bat</code> . You can modify the script and set it to the full path of ALARMPROGRAM in the onconfig file.
<code>log_full.bat</code>	Windows	
<code>no_log.sh</code>	UNIX	To disable automatic logical-log backups, set ALARMPROGRAM to <code>no_log.sh</code> or <code>no_log.bat</code> .
<code>no_log.bat</code>	Windows	
<code>alarmprogram.sh</code>	UNIX	Handles event alarms and controls logical-log backups. Modify <code>alarmprogram.sh</code> or <code>alarmprogram.bat</code> and set ALARMPROGRAM to the full pathname of <code>alarmprogram.sh</code> or <code>alarmprogram.bat</code> . See “Customizing the ALARMPROGRAM Scripts” on page C-1.
<code>alarmprogram.bat</code>	Windows	

Important: Backup media should always be available for automatic log backups.

Instead of using the supplied scripts, you can write your own shell script, batch file, or binary program to execute events. Set ALARMPROGRAM to the full pathname of this file. The database server executes this script when noteworthy events occur. These events include database, table, index, or simple-large-object failure; all logs are full; internal subsystem failure; initialization failure; and long transactions. You can have the events noted in an email or pagermail message.

To generate event alarms, set ALARMPROGRAM to \$INFORMIXDIR/etc/alarmprogram.sh or %INFORMIXDIR%\etc\alarmprogram.bat and modify the file according.

Important: When you choose automatic logical-log backups, backup media should always be available for the backup process.

Do not use the continuous log backup command (**onbar -b -l -C**) if you have automatic log backup setup through the ALARMPROGRAM parameter.

Related concepts:

Appendix C, “Event Alarms,” on page C-1

Related tasks:

“Customizing the ALARMPROGRAM Scripts” on page C-1

Related reference:

“onmode -wf, -wm: Dynamically change certain configuration parameters” on page 15-26

“Writing Your Own Alarm Script” on page C-1

“ALRM_ALL_EVENTS configuration parameter” on page 1-28

ALLOW_NEWLINE Configuration Parameter

Use the ALLOW_NEWLINE configuration parameter to allow or disallow newline characters in quoted strings for all sessions.

To allow all remote sessions in a distributed query to support embedded newline characters, specify ALLOW_NEWLINE in their ONCONFIG files.

onconfig.std *value*
0

range of values

0 = Disallow the newline character in quoted strings for all sessions.

1 = Allow the newline character in quoted strings for all sessions.

takes effect

When the database server is shut down and restarted

refer to

- Quoted strings in the *IBM Informix Guide to SQL: Syntax*
- Newline characters in quoted strings in the *IBM Informix ESQL/C Programmer's Manual*

You can specify that you want the database server to allow the newline character (\n) in a quoted string either for all sessions or for a specific session. A session is the duration of a client connection to the database server.

To allow or disallow newline characters in quoted strings for the current session when ALLOW_NEWLINE is not set, you can execute the built-in `ifx_allow_newline()` routine with 't' or 'f' as its only argument.

- 't' enables support for newline characters within quoted strings.
- 'f' has the opposite effect.

Calls to `ifx_allow_newline()` affect only the user session from which that routine is invoked.

ALRM_ALL_EVENTS configuration parameter

Use the ALRM_ALL_EVENTS configuration parameter to specify whether the ALARMPROGRAM configuration parameter runs for all events that are logged in the MSGPATH configuration parameter, or only for noteworthy events.

onconfig.std value

0

takes effect

When the database server is shut down and restarted

range of values

0, 1

If ALRM_ALL_EVENTS is set to 1, the parameter triggers the ALARMPROGRAM configuration parameter and the ALRM_ALL_EVENTS configuration parameter will display all event alarms.

Related concepts:

Appendix C, "Event Alarms," on page C-1

Related reference:

"ALARMPROGRAM configuration parameter" on page 1-26

AUTO_AIOVPS Configuration Parameter

The AUTO_AIOVPS configuration parameter enables the database server to automatically increase the number of asynchronous I/O virtual processors (AIO VPs) and page cleaner threads when the database server detects that the I/O workload has outpaced the performance of the existing AIO VPs.

onconfig.std value

1

range of values

0= Off

1 = On

takes effect

After you edit your onconfig file and restart the database server.

When you reset the value dynamically in your onconfig file by running the **onmode -wf** command.

When you reset the value for a session by running the **onmode -wm** command.

Usage

The VP **ai** configuration parameter controls the number of AIO VPs. If the VP **ai** parameter is not set in the ONCONFIG file, the initial number of AIO VPs the database server starts when AUTO_AIOVPS is enabled is equal to the number of AIO chunks. The maximum number of AIO VPs the database server can start if VP **ai** is not set is 128.

Related reference:

“onmode -wf, -wm: Dynamically change certain configuration parameters” on page 15-26

“VPCLASS configuration parameter” on page 1-167

AUTO_CKPTS configuration parameter

The AUTO_CKPTS configuration parameter allows the server to trigger checkpoints more frequently to avoid transaction blocking. You can dynamically enable or disable automatic checkpoints by using **onmode -wm** or **onmode -wf**.

onconfig.std value

1

takes effect

When the database server is shut down and restarted

range of values

0= Off

1 = On

takes effect

After you edit your onconfig file and restart the database server.

When you reset the value dynamically in your onconfig file by running the **onmode -wf** command.

When you reset the value for a session by running the **onmode -wm** command.

Related reference:

“onmode -wf, -wm: Dynamically change certain configuration parameters” on page 15-26

AUTO_LRU_TUNING configuration parameter

Use the AUTO_LRU_TUNING configuration parameter to enable automatic LRU tuning.

onconfig.std value

1

takes effect

When the database server is shut down and restarted

range of values

0= Off

1 = On

takes effect

After you edit your onconfig file and restart the database server.

When you reset the value dynamically in your `onconfig` file by running the `onmode -wf` command.

When you reset the value for a session by running the `onmode -wm` command.

Related reference:

“`onmode -wf, -wm`: Dynamically change certain configuration parameters” on page 15-26

“`BUFFERPOOL` configuration parameter” on page 1-36

AUTO_READAHEAD configuration parameter

Use the `AUTO_READAHEAD` configuration parameter to change the automatic read-ahead mode or to disable automatic read-ahead operations for a query.

onconfig.std value

`AUTO_READAHEAD 1`

values An integer from 0 - 2 that specifies the mode, optionally followed by a comma and an integer that specifies the number of pages that are automatically requested to be read ahead. For example, the value `1,4096` enables automatic read-ahead in standard mode for 4096 pages at a time.

0 = Disable automatic read-ahead requests.

1 = Enable automatic read-ahead requests in the standard mode. The database server automatically processes read-ahead requests only when a query waits on I/O.

2 = Enable automatic read-ahead requests in the aggressive mode. The database server automatically processes read-ahead requests at the start of the query and continuously through the duration of the query.

number_of_pages = 4 - 4096, indicating the number of pages that are automatically requested to be read ahead. The default is 128 pages.

separators

Separate the mode and the number of pages with a comma.

takes effect

After you edit your `onconfig` file and restart the database server.

When you reset the value dynamically in your `onconfig` file by running the `onmode -wf` command.

When you reset the value for a session by running the `onmode -wm` command.

Usage

Automatic read-ahead operations help improve query performance by issuing asynchronous page requests when the database server detects that the query is encountering I/O. Asynchronous page requests can improve query performance by overlapping query processing with the processing necessary to retrieve data from disk and put it in the buffer pool.

Generally, the default value of 1 is appropriate for most production environments.

While there are no specific circumstances in which aggressive read-ahead operations perform significantly better than standard read-ahead operations, aggressive read-ahead might be slightly more effective:

- For some scans that read a small amount of data
- In situations in which you switch between turning read-ahead off for small scans and on for longer scans
- For scans that look only at a small number of rows, because the server performs read-ahead operations immediately rather than waiting for the scan to encounter I/O.

For scans that might turn read-ahead operations off and on because the scan hits pockets of cached data, aggressive read-ahead operations do not turn off read-ahead operations.

Use aggressive read-ahead operations only in situations in which you tested both settings and know that aggressive read-ahead operations are more effective. Do not use aggressive read-ahead operations if you are not sure that they are more effective.

You can use the `AUTO_READAHEAD` environment option of the `SET ENVIRONMENT` statement of SQL to enable or disable the value of the `AUTO_READAHEAD` configuration parameter for a session.

The precedence of read-ahead setting is as follows:

1. A `SET ENVIRONMENT AUTO_READAHEAD` statement for a session.
2. The `AUTO_READAHEAD` configuration parameter value of 1 or 2.
3. If the `AUTO_READAHEAD` configuration parameter is set to 0, the value of the `RA_PAGES` configuration parameter.
4. If the `AUTO_READAHEAD` configuration parameter is set to 0 and the `RA_PAGES` configuration parameter is not set, the server performs passive read-ahead on 128 data pages when completing a query.

Related concepts:

 Sequential scans (Performance Guide)

 `AUTO_READAHEAD` environment option (SQL Syntax)

Related reference:

“onmode -wf, -wm: Dynamically change certain configuration parameters” on page 15-26

“`RA_PAGES` configuration parameter” on page 1-116

 Configure the database server to read ahead (Administrator's Guide)

AUTO_REPREPARE configuration parameter

The `AUTO_REPREPARE` configuration parameter controls whether an Informix feature is in effect that automatically re-optimizes SPL routines and re-prepares prepared objects after the schema of a table referenced by the SPL routine or by the prepared object has been changed.

onconfig.std *value*

1

takes effect

When the database server is shut down and restarted

range of values

- 0= Disables the automatic reparation of prepared objects after the schema of a directly or an indirectly referenced table is modified. Also

disables the automatic reoptimization of SPL routines after the schema of an indirectly referenced table is modified.

- 1 = Enables the automatic reparation and automatic reoptimization feature.

refer to `PREPARE`, `UPDATE STATISTICS`, and `SET ENVIRONMENT` in *IBM Informix Guide to SQL: Syntax*

takes effect

After you edit your `onconfig` file and restart the database server.

When you reset the value dynamically in your `onconfig` file by running the **`onmode -wf`** command.

When you reset the value for a session by running the **`onmode -wm`** command.

Usage

By enabling the `AUTO_REPREPARE` configuration parameter, you can avoid many -710 errors and reduce the number of reprepare and reoptimize operations that you must perform manually after the schema of a table is modified.

For example, certain DDL statements modify the schema of a table, such as `CREATE INDEX`, `DROP INDEX`, `DROP COLUMN`, and `RENAME COLUMN`. If the `AUTO_REPREPARE` configuration parameter is disabled when these DDL statements are run users might receive -710 errors. These errors occur the next time that:

- You run an SPL routine that indirectly references the tables that were modified by the DDL statements.
- You run a prepared object that references the tables that were modified by the DDL statements.
-

Related concepts:

 [IFX_AUTO_REPREPARE Environment Option \(SQL Syntax\)](#)

Related reference:

“`onmode -wf`, `-wm`: Dynamically change certain configuration parameters” on page 15-26

AUTO_STAT_MODE configuration parameter

Use the `AUTO_STAT_MODE` configuration parameter to enable or disable the mode for selectively updating only stale or missing data distributions in `UPDATE STATISTICS` operations. You can also dynamically enable or disable this selective mode for updating statistics by using the **`onmode -wm`** or **`onmode -wf`** commands.

`onconfig.std` *value*

1

default value

1

range of values

0 = Disables automatic `UPDATE STATISTICS` operations.

1 = Enables automatic `UPDATE STATISTICS` operations.

takes effect

After you edit your `onconfig` file and restart the database server.

When you reset the value dynamically in your `onconfig` file by running the `onmode -wf` command.

When you reset the value for a session by running the `onmode -wm` command.

Usage

When the `AUTO_STAT_MODE` configuration parameter or the `AUTO_STAT_MODE` session environment variable has enabled the automatic mode for selectively updating only stale or missing data distributions in `UPDATE STATISTICS` operations, the database server uses the value of the `STATCHANGE` configuration parameter to identify table or fragment distribution statistics that need to be updated.

Related concepts:

[➤](#) `AUTO_STAT_MODE` Environment Option (SQL Syntax)

Related reference:

“`STATCHANGE` configuration parameter” on page 1-150

[➤](#) Statistics options of the `CREATE TABLE` statement (SQL Syntax)

BATCHEDREAD_INDEX configuration parameter

Use the `BATCHEDREAD_INDEX` configuration parameter to enable the optimizer to automatically fetch a set of keys from an index buffer. This reduces the number of times that a buffer is read, thus improving performance.

onconfig.std value

`BATCHEDREAD_INDEX 1`

values 0 = Disable automatically fetching keys from an index buffer.

1 = Enable automatically fetching keys from an index buffer.

takes effect

After you edit your `onconfig` file and restart the database server.

When you reset the value dynamically in your `onconfig` file by running the `onmode -wf` command.

When you reset the value for a session by running the `onmode -wm` command.

Related reference:

“`onmode -wf, -wm`: Dynamically change certain configuration parameters” on page 15-26

BATCHEDREAD_TABLE configuration parameter

Use the `BATCHEDREAD_TABLE` configuration parameter to enable or disable light scans on compressed tables, tables with rows that are larger than a page, and tables with `VARCHAR`, `LVARCHAR`, and `NVARCHAR` data.

onconfig.std value

`BATCHEDREAD_TABLE 1`

values 0 = Disable light scans.

1 = Enable light scans.

takes effect

After you edit your onconfig file and restart the database server.

When you reset the value dynamically in your onconfig file by running the **onmode -wf** command.

When you reset the value for a session by running the **onmode -wm** command.

Usage

You can use the IFX_BATCHEDREAD_TABLE environment option of the SET ENVIRONMENT statement to override the value of the BATCHEDREAD_TABLE configuration parameter for a session.

Related concepts:

 Light scans (Performance Guide)

Related reference:

“onmode -wf, -wm: Dynamically change certain configuration parameters” on page 15-26

 SET ENVIRONMENT statement (SQL Syntax)

BLOCKTIMEOUT configuration parameter

Use the BLOCKTIMEOUT configuration parameter to specify the number of seconds that a thread or database server will hang. After the timeout, the thread or database server will either continue processing or fail.

onconfig.std value
3600

units Seconds

takes effect

After you edit your onconfig file and restart the database server.

When you reset the value dynamically in your onconfig file by running the **onmode -wf** command.

When you reset the value for a session by running the **onmode -wm** command.

Related reference:

“onmode -wf, -wm: Dynamically change certain configuration parameters” on page 15-26

BTSCANNER Configuration Parameter

Use the BTSCANNER configuration parameter to set the B-tree scanner. The B-tree scanner improves transaction processing for logged databases when rows are deleted from a table with indexes. The B-tree scanner threads remove deleted index entries and rebalance the index nodes. The B-tree scanner automatically determines which index items are to be deleted.

onconfig.std value
BTSCANNER num=1,threshold=5000,range=-
1,alice=6,compression=default

range of values

See the Usage section.

separators

Use a comma between each field.

takes effect

After you edit your onconfig file and restart the database server.

When you reset the value dynamically in your onconfig file by running the **onmode -C** command.

After you run the SQL administration API **task()** or **admin()** function with the **onmode** and **C** arguments.

Usage

By default, the BTSCANNER configuration parameter starts one index cleaner thread, prioritizes cleaning indexes that have over 5000 deleted items, automatically adjusts the mode of index cleaning, and merges index pages at a level appropriate for indexes that have moderate growth and changes.

Syntax for the BTSCANNER configuration parameter

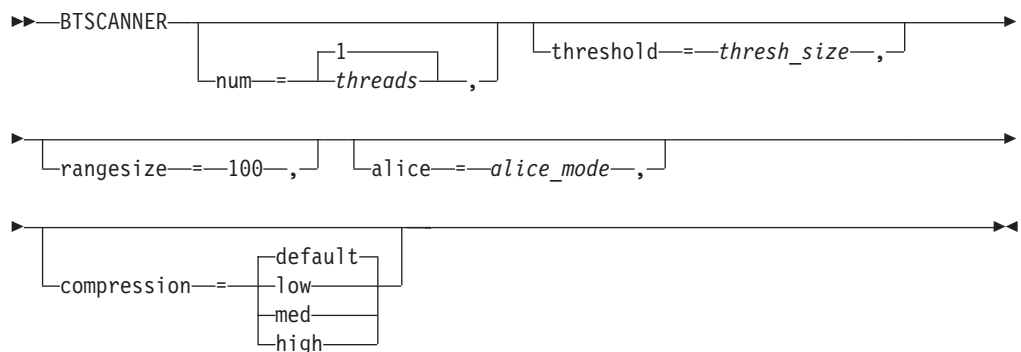

Table 1-55. Options for the BTSCANNER configuration parameter value

Field	Values
num	The <i>threads</i> value is a positive integer that sets the number of B-tree scanner threads to start at system startup. The default is 1.
threshold	The <i>thresh_size</i> value is the minimum number of deleted items an index must encounter before an index is prioritized for cleaning. The default is 5000.
rangesize	Specifies whether to allow leaf scans for small indexes: <ul style="list-style-type: none">• -1 = Off. The alice mode is used for all index cleaning.• 100 = Small indexes are scanned by the leaf scan method.
alice	The <i>alice_mode</i> value controls index cleaning: <ul style="list-style-type: none">• 0 = Off.• 1 = Uses exactly 8 bytes of memory.• 2 = Uses exactly 16 bytes of memory.• 3 - 12 = Default is 6. Sets the initial amount of memory that is used for index cleaning. Subsequently, the B-tree scanners automatically adjust the mode based on the efficiency of past cleaning operations.

Table 1-55. Options for the BTSCANNER configuration parameter value (continued)

Field	Values
compression	<p>The level at which two partially used index pages are merged:</p> <ul style="list-style-type: none"> • low = Use if you expect an index to grow quickly with frequent splits. • med or default = Default. Use if an index has moderate growth or changes. • high = Use if an index is 90 percent or more read-only or does not have many changes.

After all of the indexes above the threshold are cleaned, the indexes below the threshold are added to the prioritized list of indexes to be cleaned. Systems updated frequently should increase this value by a factor of 10 times or 100 times.

Related concepts:

 Configure B-tree scanner information to improve transaction processing (Performance Guide)

Related reference:

“onmode -C: Control the B-tree scanner” on page 15-5

“onmode and C arguments: Control the B-tree scanner (SQL administration API)” on page 22-74

BUFFERPOOL configuration parameter

Use the BUFFERPOOL configuration parameter to specify the default values for buffers and LRU queues in a buffer pool for both the default page size buffer pool and for any non-default pages size buffer pools.

onconfig.std values

Operating systems with 2K default page size:

```

BUFFERPOOL default,buffers=10000,lrus=8,lru_min_dirty=50.00,
lru_max_dirty=60.50
BUFFERPOOL size=2k,buffers=50000,lrus=8,lru_min_dirty=50,
lru_max_dirty=60
    
```

Operating systems with 4K default page size:

```

BUFFERPOOL default,buffers=10000,lrus=8,lru_min_dirty=50.00,
lru_max_dirty=60.50
BUFFERPOOL size=4k,buffers=10000,lrus=8,lru_min_dirty=50,
lru_max_dirty=60
    
```

values See the Usage section.

separators

Separate fields with a comma.

takes effect

After you edit your onconfig file and restart the database server.

When you add an entry dynamically in your onconfig file by running the **onparams -b** command.

When you add an entry dynamically by adding a dbspace with a different page size by running the **onspaces -c -d** command.

After you add an entry dynamically in your onconfig file by running the SQL administration API `task()` or `admin()` function with the `add bufferpool` argument.

Usage

The BUFFERPOOL configuration parameter has two entries in the onconfig.std file:

- The first entry specifies the default values for a buffer pool for a dbspace with a non-default page size. The buffer pool uses the page size of the dbspace, has up to 10 000 buffers, has eight LRU queues, and the LRU queue is cleaned when between 60.50% and 50% of the pages are modified.
- The second entry specifies the default values for a buffer pool based on the default page size of the system. The buffer pool uses the default page size of the system, has up to 10 000 buffers, has eight LRU queues, and the LRU queue is cleaned when between 60% and 50% of the pages are modified.

The BUFFERPOOL configuration parameter entries that include the `size` field take precedence over the entry that includes the `default` field.

Syntax for the BUFFERPOOL configuration parameter

```

▶—BUFFERPOOL—default———, —buffers—==—number_buffers—, —————▶
      |——size——==—page_sizek——|
▶—lrus——==—number_lrus—, —lru_min_dirty——==—min_percentage—, —————▶
▶—lru_max_dirty——==—max_percentage———▶
  
```

Table 1-56. Options for the BUFFERPOOL configuration parameter value

Field	Values
size	<p>The <code>page_size</code> value specifies the page size for buffers, in KB. The page size must be 2 - 16 KB and must be a multiple of the default page size. For example, if the default page size is 2 KB, the page size can be 2, 4, 6, 8, 10, 12, 14, or 16. If the default page size is 4 KB, the page size can be 4, 8, 12, or 16. The default value depends on the system default page size:</p> <ul style="list-style-type: none"> • 2K default page size: <code>size=2k</code> • 4K default page size: <code>size=4k</code> <p>The k is optional.</p>

Table 1-56. Options for the BUFFERPOOL configuration parameter value (continued)

Field	Values
buffers	<p>The <i>number_buffers</i> value is an integer 100 - 2 147 483 647 that specifies the maximum number of shared-memory buffers for disk I/O on behalf of client applications. The range of values depends on the bit size, the page size, and the operating system:</p> <ul style="list-style-type: none"> • For 32-bit platform on UNIX with a 2K page size: 100 - 1,843,200 (1843200 = 1800 * 1024) • For 32-bit platform on UNIX with a 4K page size: 100 - 921,600 (921,600 = ((1800 * 1024)/4096) * 2048) • For 32-bit platform on Windows: 100 - 524,288 (524,288 = 512 * 1024) • For 64-bit platforms: 100 - (2³¹-1). For the actual value for your 64-bit platform, see your machine notes. For example, the maximum number of buffers on the Solaris platform is 536,870,912. <p>Each buffer is the size of the operating system page. Therefore, the number of buffers that the database server requires depends on the applications. For example, if the database server accesses 15 percent of the application data 90 percent of the time, allocate enough buffers to hold 15 percent of the data. Increasing the number of buffers can improve system performance. The number of buffers can have a significant affect on performance and use a large percentage of physical memory.</p>
lrus	<p>The <i>number_lrus</i> values is a positive integer that specifies the number of LRU (least recently used) queues in the shared-memory buffer pool. The range of values depends on the bit size of the operating system:</p> <ul style="list-style-type: none"> • 32-bit platforms: 1 - 128 • 64-bit platforms: 1 - 512 <p>The value of lrus field, in combination with the lru_min_dirty and lru_max_dirty fields control how frequently the shared-memory buffers are flushed to disk. Setting the value of the lrus field too high might result in excessive page-cleaner activity.</p>
lru_min_dirty	<p>The <i>min_percentage</i> value is a decimal number 0 - 100 that sets the percentage of modified pages in the LRU queues at which page cleaning is no longer mandatory. The default value is 50.00.</p> <p>Page cleaners might continue cleaning beyond the specified percentage under some circumstances.</p> <p>This value is updated automatically as needed if the AUTO_LRU_TUNING configuration parameter is enabled.</p>
lru_max_dirty	<p>The <i>max_percentage</i> value is a decimal number 0 - 100 that sets the percentage of modified pages in the LRU queues at which the queue is cleaned. The default value is 60.50.</p> <p>This value is updated automatically as needed if the AUTO_LRU_TUNING configuration parameter is enabled.</p>

When you add a dbspace with a different page size with the **onspaces** utility or when you add a buffer pool with the **onparams** utility, an additional BUFFERPOOL configuration parameter entry is added in the onconfig file. The following example shows a third entry:

```
BUFFERPOOL default,buffers=10000,lrus=8,lru_min_dirty=50.00,lru_max_dirty=60.50
BUFFERPOOL size=2k,buffers=10000,lrus=8,lru_min_dirty=50,lru_max_dirty=60
BUFFERPOOL size=6k,buffers=3000,lrus=8,lru_min_dirty=50,lru_max_dirty=60
```

When you create a dbspace with a non-default page size, the database server uses the existing BUFFERPOOL entry for that page size, if that entry exists. Otherwise, the database server uses the values from the BUFFERPOOL default line.

All dbspaces using a particular page size use the buffer pool with that page size. You cannot change the values by editing the onconfig file. If you need to resize or delete an existing buffer pool, you must restart the database server and then run the **onparams -b** command again.

Buffer pools that are added while the database server is running are in virtual memory, not resident memory. Only those buffer pool entries that are specified in the onconfig file at startup are in resident memory.

The fields in the BUFFERPOOL entries are not case sensitive and the fields can be listed in any order.

Related concepts:

 The BUFFERPOOL configuration parameter and memory utilization (Performance Guide)

Related tasks:

 Creating a dbspace with a non-default page size (Administrator's Guide)

Related reference:

Appendix D, “Discontinued configuration parameters,” on page D-1

“onparams -b: Add a new buffer pool” on page 17-4

“Specifying a Non-Default Page Size with the Same Size as the Buffer Pool” on page 20-10

“add bufferpool argument: Add a buffer pool (SQL administration API)” on page 22-13

 Determine database server page size (Administrator's Guide)

“onspaces -c -d: Create a dbspace” on page 20-7

“AUTO_LRU_TUNING configuration parameter” on page 1-29

CHECKALLDOMAINSFORUSER configuration parameter

Use the CHECKALLDOMAINSFORUSER configuration parameter to check all of the domains for all users.

onconfig.std *value*

Not in the **onconfig.std** file

takes effect

When the database server is shut down and restarted.

range of values

0 = Disabled

1 = Enabled

Related concepts:

 [Windows network domain \(Administrator's Guide\)](#)

CKPTINTVL configuration parameter

Use the CKPTINTVL configuration parameter to specify the frequency, expressed in seconds, at which the database server checks to determine whether a checkpoint is needed. When a checkpoint occurs, all pages in the shared-memory buffer pool are written to disk.

onconfig.std *value*
300

units Seconds

range of values
Any value greater than or equal to 0

takes effect

When the database server is shut down and restarted.

RTO_SERVER_RESTART and CKPTINTVL are mutually exclusive. If the RTO_SERVER_RESTART configuration parameter is enabled, it will trigger checkpoints and CKPTINTVL values are ignored. Otherwise, CKPTINTVL values are used to trigger checkpoints.

takes effect

After you edit your onconfig file and restart the database server.

When you reset the value dynamically in your onconfig file by running the **onmode -wf** command.

When you reset the value for a session by running the **onmode -wm** command.

refer to

- Checkpoints, in the shared-memory and fast-recovery chapters of the *IBM Informix Administrator's Guide*
- Your *IBM Informix Performance Guide*

Usage

If you set the CKPTINTVL configuration parameter to an interval that is too short, the system spends too much time performing checkpoints, and the performance of other work suffers. If you set the CKPTINTVL configuration parameter to an interval that is too long, fast recovery might take too long.

In practice, 30 seconds is the smallest interval that the database server checks. If you specify a checkpoint interval of 0, the database server does not check if the checkpoint interval has elapsed. However, the database server still performs checkpoints. Other conditions, such as the physical log becoming 75 percent full, also cause the database server to perform checkpoints.

Related reference:

“onmode -wf, -wm: Dynamically change certain configuration parameters” on page 15-26

CLEANERS Configuration Parameter

Use the CLEANERS configuration parameter to specify the number of page-cleaner threads available during the database server operation. By default, the database server always runs one page-cleaner thread. A general guideline is one page cleaner per disk drive. The value specified has no effect on the size of shared memory.

Based on the server work load, the server automatically attempts to optimize AIO VPs and page-cleaner threads and adjust the number of AIO VPs and page-cleaner threads upward when needed. Automatic AIO VP and page-cleaner thread tuning can be disabled using the environmental variable IFX_NO_AIOVP_TUNING or the onmode -wm utility option.

onconfig.std *value*
8

units Number of page-cleaner threads

range of values
1 through 128

takes effect
When the database server is shut down and restarted.

utilities
onstat -F (see “onstat -F command: Print counts” on page 21-40.)

refer to How the database server flushes data to disk, in the shared-memory chapter of the *IBM Informix Administrator's Guide*

CONSOLE configuration parameter

Use the CONSOLE configuration parameter to specify the path and name for console-message file.

onconfig.std *value*
On UNIX: **\$INFORMIXDIR/tmp/online.con**
On Windows: **online.con**

range of values
Pathname

takes effect
When the database server is shut down and restarted

refer to The system console in the chapter on database server administration in the *IBM Informix Administrator's Guide*

CONVERSION_GUARD configuration parameter

Use the CONVERSION_GUARD configuration parameter to specify whether Informix stops or continues an upgrade to a new version of the server if an error occurs during the upgrade process.

onconfig.std *value*

2

units Integer

range of values

0 = Disabled.

1= Enable a restore point as part of the upgrade process, and stop the upgrade if an error related to capturing restore point data occurs.

2= Enable a restore point as part of the upgrade process, and continue the upgrade even if an error related to capturing restore point data occurs.

takes effect

When the database server is restarted

By default:

- The `CONVERSION_GUARD` configuration parameter is on (set to 2). If an upgrade to the new version of the server fails, you can use the **onrestorept** utility to restore your data.
- The server will store the restore point data in the `$INFORMIXDIR/tmp` directory.

If the `CONVERSION_GUARD` configuration parameter is set to 1 or 2 and the upgrade to the new version of the server fails, you can use the **onrestorept** utility to restore your data.

If the `CONVERSION_GUARD` configuration parameter is set to 2 and conversion guard operations fail (for example, because the server has insufficient space to store restore point data), and the upgrade fails, you cannot use the **onrestorept** utility to restore your data.

You can change the value of the `CONVERSION_GUARD` configuration parameter or change the directory specified in the `RESTORE_POINT_DIR` configuration parameter before starting the server that initiates an upgrade to a new version of the server. You cannot change the `CONVERSION_GUARD` or `RESTORE_POINT_DIR` values during an upgrade.

For information about the **onrestorept** utility, which you can run to undo changes made during a failed upgrade, see the *IBM Informix Migration Guide*.

DATASKIP Configuration Parameter

Use the `DATASKIP` configuration parameter to control whether the database server skips a dbspace that is unavailable during the processing of a transaction.

onconfig.std *value*

Not set. No dbspaces are skipped.

values See the Usage section.

takes effect

After you edit your `onconfig` file and restart the database server.

When you reset the value dynamically in your `onconfig` file by running the **onspaces -f** command.

After you run the SQL administration API **task()** or **admin()** function with the **set dataskip** argument.

Usage

Whenever the database server skips over a dbspace during query processing, a warning is returned.

Enable the DATASKIP configuration parameter with caution because the results are always suspect. Only enable the parameter in the following situations:

- You can accept the compromised integrity of transactions.
- You can determine that the integrity of the transaction is not compromised, which can be difficult and time consuming.

Syntax for the DATASKIP configuration parameter

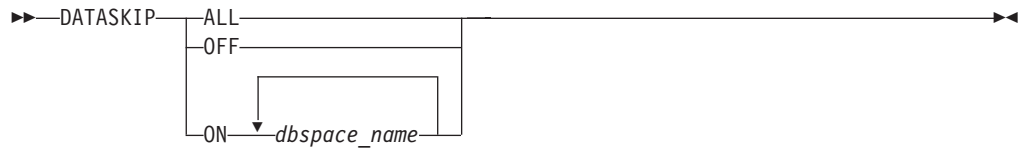

Table 1-57. Options for the DATASKIP configuration parameter value

Field	Description
ALL	Skip all unavailable fragments.
OFF	All fragments, including unavailable fragments, are processed.
ON	The <i>dbspace_name</i> value specifies one or more dbspaces to skip, separated by blank spaces.

An application can use the SQL statement SET DATASKIP to override the value of the DATASKIP configuration parameter.

The previously reserved SQLCA warning flag `sqlwarn.sqlwarn7` is set to W for IBM Informix ESQL/C.

Related concepts:

[How DATASKIP affects table I/O \(Performance Guide\)](#)

Related reference:

“onspaces -f: Specify DATASKIP parameter” on page 20-21

“`onstat -f` command: Print dbspace information affected by dataskip” on page 21-40

“set dataskip argument: Start or stop skipping a dbspace (SQL administration API)” on page 22-107

[SET DATASKIP statement \(SQL Syntax\)](#)

DBCREATE_PERMISSION Configuration Parameter

Use the DBCREATE_PERMISSION configuration parameter to restrict the permission to create databases to the user that you specify.

The **informix** user always has permission to create databases. To restrict the ability to create databases to the **informix** user, add the following line to the ONCONFIG file:

```
DBCREATE_PERMISSION informix
```

syntax DBCREATE_PERMISSION *value*

onconfig.std *value*
informix (suggested value, but not set)

units usernames

separator
Comma. You can also include multiple copies of the DBCREATE_PERMISSION configuration parameter in the ONCONFIG file to give additional users permission to create databases.

takes effect
When the database server is shut down and restarted

DB_LIBRARY_PATH Configuration Parameter

Use the DB_LIBRARY_PATH configuration parameter to specify a comma-separated list of valid directory prefix locations from which the database server can load external modules, such as DataBlade Modules. You can also include server environment variables, such as \$INFORMIXDIR, in the list.

You must specify the paths to the external modules exactly as the paths are registered with the database server. Relative paths or paths that include double periods (..) are not valid. External modules in the file systems that are not specified by this parameter cannot be loaded. This list is scanned prior to loading C language modules.

If you set this configuration parameter, you must also include the string \$INFORMIXDIR/extend as part of the value. If the string \$INFORMIXDIR/extend is not included in DB_LIBRARY_PATH, IBM-supplied DataBlade Modules, the BladeManager, Large Object Locator DataBlade module functions, and DataBlade modules that you created with the DataBlade Developers Kit will not load.

syntax DB_LIBRARY_PATH *value*

onconfig.std *value*
Not set

if not present
The database server can load external modules from any location

range of values
List of path names (up to 512 bytes)

separators
Comma

takes effect
When the database server is shut down and restarted

DBSERVERALIASES configuration parameter

Use the DBSERVERALIASES configuration parameter to specify an alias name, or a list of unique alias names for the database server. Each alias defined by the DBSERVERALIASES configuration parameter can be used in a different connection, as specified by entries in the sqlhosts file (UNIX) or of the SQLHOSTS registry (Windows).

onconfig.std *value*
Not set. No aliases are defined.

values One to 32 alias names, separated by commas. Each alias name can be optionally followed by a minus sign and an integer from 1 - 50 that specifies the number of multiple listener threads to use for the **onimcsoc** or **onsoctcp** protocols. For example, the following two alias names each have four listener threads: `alias_a-4,alias_b-4`. The listener thread number is ignored for other protocols.

The maximum length of an alias is 128 bytes. Additional aliases beyond 32 are ignored. The maximum length of a DBSERVERALIASES entry is 512 bytes. You can include multiple lines of DBSERVERALIASES configuration parameters in the `onconfig` file.

An alias name must begin with a letter and can include any printable character, except the following:

- Uppercase characters
- A field delimiter (blank space or tab)
- A newline character
- A comment character (#)
- A hyphen or minus (= ASCII 45) character
- The @ character
- A blank space

separators

Separate entries with a comma. Do not include blank spaces.

takes effect

After you edit your `onconfig` file and restart the database server and update the `sqlhosts` file or registry of each database server.

Usage

You can use the DBSERVERALIASES configuration parameter to specify aliases for both Secure Sockets Layer (SSL) and for non-SSL connection protocols.

If Informix supports more than one communication protocol (for example, both an IPC mechanism and the TCP network protocol), you must describe each valid connection to the database server with an entry in the `sqlhosts` file or SQLHOSTS registry. For example, suppose you have a server that has the name `sanfrancisco` defined by the DBSERVERNAME configuration parameter setting, and you set a DBSERVERALIASES value of `menlo` for an SSL connection. You must specify information for both of the `sanfrancisco` and `menlo` servers in the `sqlhosts` file or in the SQLHOSTS registry. Similarly, if the database server needs to support both the standard Informix protocols and the Distributed Relational Database Architecture™ (DRDA) protocols, assign an alias to the DRDA database server and add an entry for this alias in the `sqlhosts` file.

For each alias listed in the DBSERVERALIASES configuration parameter, the database server starts an additional listener thread. If you have many client applications connecting to the database server, you can distribute the connection requests between several listener threads and speed connection times. To take advantage of the alternate connections, program some of your client applications to connect to a database server alias name instead of the database server name.

If you use Informix MaxConnect with more than one communication protocol, specify additional database server aliases for the DBSERVERALIASES configuration parameter. The value of the **INFORMIXSERVER** environment variable on

the client must match either the value of the DBSERVERNAME configuration parameter or one of the values of the DBSERVERALIASES configuration parameter.

Related concepts:

[🔗](#) Multiple connection types (Administrator's Guide)

Related reference:

“DBSERVERNAME configuration parameter”

[🔗](#) ONCONFIG parameters related to connectivity (Administrator's Guide)

[🔗](#) Add listen threads (Administrator's Guide)

“NETTYPE Configuration Parameter” on page 1-101

“NUMFDSERVERS configuration parameter” on page 1-106

DBSERVERNAME configuration parameter

Use the DBSERVERNAME configuration parameter to specify a unique name that you want to associate with the database server. You specify this configuration parameter when you install the database server.

onconfig.std value

Not set. A database server name is not defined.

if not present

On UNIX: *hostname*

On Windows: *ol_hostname*The *hostname* variable is the name of the host computer.

values A database server name that has a maximum length of 128 bytes.The database server name can be optionally followed by a minus sign and an integer from 1 - 50 that specifies the number of multiple listener threads to use for the **onimcsoc** or **onsoctcp** protocols. The default number of listener threads is 1. For example, the following database server name has four listener threads: *ifxserver-4*. The listener thread number is ignored for other protocols.

A database server name must begin with a letter and can include any printable character, except the following:

- Uppercase characters
- A field delimiter (blank space or tab)
- A newline character
- A comment character (#)
- A hyphen or minus (= ASCII 45) character
- The @ character
- A blank space

takes effect

After you edit your *onconfig* file and restart the database server and update the *sqlhosts* file or registry of each database server. In addition, the **INFORMIXSERVER** environment variable for all users might need to be changed.

Usage

The database server name is associated with a communication protocol that is specified in the `sqlhosts` file or registry. If the database server uses multiple communication protocols, define values for database server names with the `DBSERVERALIASES` configuration parameter.

Client applications use the database server name in the `INFORMIXSERVER` environment variable and in SQL statements such as `CONNECT` and `DATABASE`, which establish a connection to a database server.

Important: To avoid conflict with other instances of Informix database servers on the same computer or node, you should use the `DBSERVERNAME` configuration parameter to assign a database server name explicitly.

For Informix MaxConnect users, the value of the `INFORMIXSERVER` environment variable on the client must match either the value of the `DBSERVERNAME` configuration parameter or one of the entries of the `DBSERVERALIASES` configuration parameter.

Related concepts:

[➡](#) Multiple connection types (Administrator's Guide)

Related reference:

“`DBSERVERALIASES` configuration parameter” on page 1-44

[➡](#) Connection information set in the `DBSERVERNAME` configuration parameter (Administrator's Guide)

[➡](#) Add listen threads (Administrator's Guide)

[➡](#) `INFORMIXSERVER` environment variable (SQL Reference)

“`NETTYPE` Configuration Parameter” on page 1-101

“`NUMFDSERVERS` configuration parameter” on page 1-106

DBSPACETEMP configuration parameter

Use the `DBSPACETEMP` configuration parameter to specify a list of dbspaces that the database server uses to globally manage the storage of temporary tables.

`DBSPACETEMP` improves performance by enabling the database server to spread out I/O for temporary tables efficiently across multiple disks. The database server also uses temporary dbspaces during backups to store the before-images of data that are overwritten while the backup is occurring.

onconfig.std *value*

None

if not present

ROOTNAME

separators

Comma or colon (no white space)

range of values

The list of dbspaces can contain standard dbspaces, temporary dbspaces, or both. Use a colon or comma to separate the dbspaces in your list. The length of the list cannot exceed 254 bytes.

takes effect

After you edit your onconfig file and restart the database server.

When you reset the value dynamically in your onconfig file by running the **onmode -wf** command.

When you reset the value for a session by running the **onmode -wm** command.

environment variable **DBSPACETEMP**

Specifies dbspaces that the database server uses to store temporary tables for a particular session. If **DBSPACETEMP** is not set, the default location is the **root** dbspace.

utilities

onspaces -t (see “Creating a temporary dbspace with the onspaces -t command” on page 20-10.) **onstat -d flags** field (see “onstat -d command: Print chunk information” on page 21-34.)

refer to

- What is a temporary table, in the chapter on data storage in the *IBM Informix Administrator's Guide*
- *IBM Informix Guide to SQL: Reference*
- The order of precedence that the database server uses when it creates implicit sort files, in the *IBM Informix Performance Guide*
- The order of precedence of the default locations where the database server stores logged and unlogged temporary tables in the *IBM Informix Guide to SQL: Reference*.

Usage

DBSPACETEMP can contain dbspaces with a non-default page size, but all of the dbspaces in the **DBSPACETEMP** list must have the same page size. For more information about dbspaces in non-default buffer pools, see “**BUFFERPOOL** configuration parameter” on page 1-36.

If a client application needs to specify an alternative list of dbspaces to use for its temporary-table locations, the client can use the **DBSPACETEMP** environment variable to list them. The database server uses the storage locations that the **DBSPACETEMP** environment variable specifies only when you use the **HIGH** option of **UPDATE STATISTICS**.

If both standard and temporary dbspaces are listed in the **DBSPACETEMP** configuration parameter or environment variable, the following rules apply:

- Sort, backup, implicit, and nonlogging explicit temporary tables are created in temporary dbspaces if adequate space exists.
- Explicit temporary tables created without the **WITH NO LOG** option are created in standard (rather than temporary) dbspaces.

When you create a temporary dbspace with **ISA** or with the **onspaces** utility, the database server does not use the newly created temporary dbspace until you perform the following steps.

To enable the database server to use the new temporary dbspace:

1. Add the name of a new temporary dbspace to your list of temporary dbspaces in the **DBSPACETEMP** configuration parameter, the **DBSPACETEMP** environment variable, or both.

- Restart the database server with the **oninit** command (UNIX) or restart the database server service (Windows).

If you use the **DBSPACETEMP** environment variable to create a temporary dbspace in a user session, the change takes effect immediately and overrides the **DBSPACETEMP** value in the **ONCONFIG** file.

Related reference:

“onmode -wf, -wm: Dynamically change certain configuration parameters” on page 15-26

 [DBSPACETEMP environment variable \(SQL Reference\)](#)

 [PSORT_DBTEMP environment variable \(SQL Reference\)](#)

Use Hash Join Overflow and DBSPACETEMP

Informix uses an operating-system directory or file to direct any overflow that results from certain database operations, if you do not set the **DBSPACETEMP** environment variable or **DBSPACETEMP** configuration parameter.

You can specify the operating-system directory or file in the following ways:

- SELECT statement with GROUP BY clause
- SELECT statement with ORDER BY clause
- Hash-join operation
- Nested-loop join operation
- Index builds

Location of the sort overflow files

The following table lists the environment variables and ONCONFIG configuration parameters that you can use to specify the location of the sort overflow files.

Table 1-58. Location of sort overflow files

Variable or Parameter	Location of the sort overflow files
PSORT_DBTEMP environment variable	The location specified in the environment variable
DBSPACETEMP environment variable	The location specified in the environment variable
DBSPACETEMP configuration parameter specified in the ONCONFIG file	The dbspace that is specified in the ONCONFIG file DBSPACETEMP configuration parameter

If more than one variable or parameter is specified, the priority by which the Informix determines the location of the sort overflow files is:

1. PSORT_DBTEMP environment variable
2. DBSPACETEMP environment variable
3. DBSPACETEMP ONCONFIG variable
4. DUMPDIR
5. \$INFORMIXDIR/tmp

If the environment variables or configuration parameter are not set, the sort overflow files are placed in the **\$INFORMIXDIR/tmp** directory and the temporary tables are placed in the rootdbspace.

DD_HASHMAX configuration parameter

Use the DD_HASHMAX configuration parameter to specify the maximum number of tables in each hash bucket in the data-dictionary cache.

A *hash bucket* is the unit of storage (typically a page) whose address is computed by the hash function. A hash bucket contains several records.

For example, if the DD_HASHMAX configuration parameter is set to 10 and the DD_HASHSIZE configuration parameter is set to 59, you can store information about 590 tables in the data-dictionary cache, and each hash bucket can have a maximum of 10 tables.

onconfig.std *value*

10

units Maximum number of tables in a hash bucket

range of values

Positive integers

takes effect

When the database server is shut down and restarted

utilities

Use a text editor to modify the configuration file.

refer to

- Configuration effects on memory, in your *IBM Informix Performance Guide*
- “DD_HASHSIZE Configuration Parameter”

DD_HASHSIZE Configuration Parameter

Use the DD_HASHSIZE configuration parameter to specify the number of hash buckets or lists that are in the data-dictionary cache.

onconfig.std *value*

31

units Number of hash buckets or lists

range of values

Any positive integer; a prime number is recommended

takes effect

When the database server is shut down and restarted

utilities

Use a text editor to modify the configuration file.

refer to

- Configuration effects on memory, in your *IBM Informix Performance Guide*
- “DD_HASHMAX configuration parameter”

DEADLOCK_TIMEOUT configuration parameter

Use the DEADLOCK_TIMEOUT configuration parameter to specify the maximum number of seconds that a database server thread can wait to acquire a lock.

Use this parameter only for distributed queries that involve a remote database server. Do not use this parameter for nondistributed queries.

onconfig.std *value*

60

units Seconds

range of values

Positive integers

utilities

constat -p *dlouts* field (See “**onstat -p** command: Print profile counts” on page 21-200.)

takes effect

After you edit your onconfig file and restart the database server.

When you reset the value dynamically in your onconfig file by running the **onmode -wf** command.

When you reset the value for a session by running the **onmode -wm** command.

Usage

If a distributed transaction is forced to wait longer than the number of seconds specified with the DEADLOCK_TIMEOUT configuration parameter, the thread that owns the transaction assumes that a multi-server deadlock exists.

Related concepts:

 Multiphase commit protocols (Administrator's Guide)

Related reference:

“onmode -wf, -wm: Dynamically change certain configuration parameters” on page 15-26

 Configuration parameters used in two-phase commits (Administrator's Guide)

DEF_TABLE_LOCKMODE configuration parameter

Use the DEF_TABLE_LOCKMODE configuration parameter to specify the lock mode at the page or row level for new tables.

onconfig.std *value*

PAGE

values PAGE = sets lock mode to page for new tables

ROW = sets lock mode to row for new tables

takes effect

After you edit your onconfig file and restart the database server.

When you reset the value dynamically in your onconfig file by running the **onmode -wf** command.

When you reset the value for a session by running the **onmode -wm** command.

precedence rules

You can supersede all other lock mode settings for a specific table by including the LOCK MODE clause in the CREATE TABLE or ALTER TABLE statement.

The `IFX_DEF_TABLE_LOCKMODE` environment variable set on the client takes precedence over the variable on the server and the `DEF_TABLE_LOCKMODE` configuration parameter.

The `IFX_DEF_TABLE_LOCKMODE` environment variable set on the server takes precedence over the `DEF_TABLE_LOCKMODE` configuration parameter.

Usage

If the `DEF_TABLE_LOCKMODE` configuration parameter is set to `ROW`, it sets the lock mode to row for every newly created table for all sessions that are connected to logging or nonlogging databases. This parameter has no effect on the lock mode for existing tables.

If the `DEF_TABLE_LOCKMODE` configuration parameter is set to `PAGE`, the `USELASTCOMMITTED` configuration parameter and `COMMITTED READ LAST COMMITTED` option of the `SET ISOLATION` statement cannot enable access to the most recently committed data in tables on which uncommitted transactions hold exclusive locks, unless the tables were explicitly created or altered to have `ROW` as their locking granularity.

Related concepts:

[➡](#) [Configuring the lock mode \(Performance Guide\)](#)

[➡](#) [Precedence and Default Behavior \(SQL Syntax\)](#)

Related reference:

“`onmode -wf, -wm`: Dynamically change certain configuration parameters” on page 15-26

[➡](#) [IFX_DEF_TABLE_LOCKMODE environment variable \(SQL Reference\)](#)

DEFAULTESCCHAR configuration parameter

The `DEFAULTESCCHAR` configuration parameter specifies the default escape character that is used.

onconfig.std *value*

The backslash character (\).

if not present

The backslash character (\) is used if no value is set in the `onconfig` file.

takes effect

When the database server is shut down and restarted.

range of values

Value	Description
\	The backslash character is used as the escape character.
None	No default escape character.
<i>character</i>	Any one-character value can be used as the escape character.

The default value can be overridden in a session by using the `SET ENVIRONMENT DEFAULTESCCHAR` statement with the escape character that you want to use. For example:

SET ENVIRONMENT DEFAULTESCCHAR '\'

Related reference:

 [DEFAULTESCCHAR Environment Option \(SQL Syntax\)](#)

DELAY_APPLY Configuration Parameter

Use the DELAY_APPLY configuration parameter to configure RS secondary servers to wait for a specified period of time before applying logs.

onconfig.std value

Not set. Write logs immediately.

values An integer followed by a time unit: for example, 1H sets the delay to one hour.

number: 0-999 = Number of days, minutes, hours, or seconds to wait.

time_unit: D, H, M, or S, where D = Days, H = Hours, M = Minutes, and S = Seconds. Values are not case sensitive.

takes effect

After you edit your onconfig file and restart the database server.

When you reset the value dynamically in your onconfig file by running the **onmode -wf** command.

When you reset the value for a session by running the **onmode -wm** command.

Usage

Delaying the application of log files allows you to recover quickly from erroneous database modifications by restoring the data from the RS secondary server. When setting the value of DELAY_APPLY you must also set LOG_STAGING_DIR. If DELAY_APPLY is configured and LOG_STAGING_DIR is not set to a valid and secure directory, then the server cannot be initialized.

You must specify a valid and secure location for the log files by setting the LOG_STAGING_DIR configuration parameter. The logs in the staging directory are purged after the last checkpoint has been processed on the RS secondary server.

Related concepts:

 [Delayed application of log records \(Administrator's Guide\)](#)

Related reference:

“onmode -wf, -wm: Dynamically change certain configuration parameters” on page 15-26

“STOP_APPLY configuration parameter” on page 1-154

“LOG_STAGING_DIR configuration parameter” on page 1-90

“onstat -g cluster command: Print high-availability cluster information” on page 21-65

DIRECT_IO Configuration Parameter (UNIX)

Use the DIRECT_IO configuration parameter to control the use of direct I/O for cooked files used for dbspace chunks.

This parameter enables direct I/O (bypassing file system buffering) on UNIX platforms or concurrent IO (bypassing both file system buffering and unnecessary write serialization) on AIX® operating systems.

onconfig.std *value*

0

range of values

0 = neither direct I/O or concurrent I/O is used

1 = direct I/O, which bypasses file system buffering, is used if available

2 = concurrent I/O is enabled on AIX operating systems (The concurrent I/O option includes direct I/O and concurrent I/O.)

takes effect

When the database server is shut down and restarted

refer to

- Direct I/O and concurrent I/O information in the *IBM Informix Performance Guide*
- Direct I/O information in the *IBM Informix Administrator's Guide*
- "AUTO_AIOVPS Configuration Parameter" on page 1-28
- "**onstat -d** command: Print chunk information" on page 21-34, which displays a flag that identifies whether direct I/O, concurrent I/O, or neither is used

Direct I/O can only be used for dbspace chunks whose file systems support direct I/O for the page size.

By using direct I/O, you might be able to reduce the number of AIO virtual processors.

If direct I/O is enabled, KAIO (kernel asynchronous I/O) is used if the file system supports it. However, KAIO is not used if the environment variable KAIOOFF is set. When direct IO and KAIO are both used, the number of AIO virtual processors can be reduced. If direct IO is used, but KAIO is not, the number of AIO virtual processors should not be reduced.

Informix does not use direct or concurrent I/O for cooked files used for temporary dbspace chunks.

On AIX, if Informix uses concurrent I/O for a chunk, another program (such as an online external backup program) must also use concurrent I/O. If not, the file open operation will fail.

If Informix uses direct I/O for a chunk, and another program tries to open the chunk file without using direct I/O, the open operation will normally succeed, but there can be a performance penalty. The penalty can occur because the file system might attempt to ensure that each open operation views the same file data, either by not using direct I/O at all for the duration of the conflicting open operation, or by flushing the file system cache before each direct I/O and invalidating the file system cache after each direct write.

Direct I/O is used for dbspace chunks on Windows platforms regardless of the value of the DIRECT_IO configuration parameter.

DIRECTIVES configuration parameter

Use the DIRECTIVES configuration parameter to enable or disable the use of optimizer directives. These directives specify behavior for the query optimizer in developing query plans for SELECT, UPDATE, and DELETE statements.

onconfig.std *value*
1

range of values

0 optimizer directives disabled

1 optimizer directives enabled

takes effect

After you edit your onconfig file and restart the database server.

When you reset the value dynamically in your onconfig file by running the **onmode -wf** command.

When you reset the value for a session by running the **onmode -wm** command.

environment variable

IFX_DIRECTIVES

Usage

Set DIRECTIVES to 1, which is the default value, to enable the database server to process optimizer directives. Set DIRECTIVES to 0 to disable the database server from processing directives.

Client programs also can set the **IFX_DIRECTIVES** environment variable to ON or OFF to enable or disable processing of directives by the database server. The setting of the **IFX_DIRECTIVES** environment variable overrides the setting of the DIRECTIVES configuration parameter. If you do not set the **IFX_DIRECTIVES** environment variable, all sessions for a client inherit the database server configuration for processing directives.

For more information about optimizer directives, see Optimizer Directives. For information about using optimizer directives in SQL syntax segments, see Other Syntax Segments.

Related reference:

“onmode -wf, -wm: Dynamically change certain configuration parameters” on page 15-26

 [IFX_DIRECTIVES environment variable \(SQL Reference\)](#)

DISABLE_B162428_XA_FIX Configuration Parameter

Use the DISABLE_B162428_XA_FIX configuration parameter to specify when transactions are freed.

onconfig.std *value*
Not in **onconfig.std**

units Integer

range of values

0 = (Default) Frees transactions only when an xa_rollback is called 1 =

Frees transactions if transaction rollback for other than an xa_rollback

takes effect

When the database server is shut down and restarted

refer to *IBM Informix Guide to SQL: Reference*

Set `DISABLE_B162428_XA_FIX` to 1 to immediately free all global transactions after a transaction rollback, which is the default for Informix 9.40 and earlier versions. The default behavior for Informix 10.0 is to free global transactions after an `xa_rollback` is called, and this behavior is required to confirm to the XA state table that a transaction can be freed only after `xa_rollback` is called. Setting `DISABLE_B162428_XA_FIX` to 1 ensures that applications written for the earlier version of Informix work properly.

You can override the `DISABLE_B162428_XA_FIX` configuration parameter for a client session with the `IFX_XASTDCOMPLIANCE_XAEND` environment variable. Setting `IFX_XASTDCOMPLIANCE_XAEND` to 1 will free transactions only when an `xa_rollback` is called. Setting `IFX_XASTDCOMPLIANCE_XAEND` to 0 will free transactions if the transaction rollback is for other than an `xa_rollback`.

Related reference:

 `IFX_XASTDCOMPLIANCE_XAEND` environment variable (SQL Reference)

DRDA_COMMBUFFSIZE Configuration Parameter

Use the `DRDA_COMMBUFFSIZE` configuration parameter to specify the size of the DRDA communications buffer.

When a DRDA session is established, the session is allocated a communication buffer equal to the current buffer size. If the buffer size is subsequently changed, existing connections are not affected, but new DRDA connections use the new size. Informix silently resets values greater than 2 Megabyte to 2 Megabytes and resets values less than 4 Kilobytes to the 32 Kilobyte default value.

onconfig.std *value*

Not in **onconfig.std**

if not present

32K

range of values

Minimum = 4 Kilobytes

Maximum = 2 Megabytes

takes effect

When shared memory is initialized

refer to *Setting the Size of the DRDA Communications Buffer in the IBM Informix Administrator's Guide.*

Users may specify the `DRDA_COMMBUFFSIZE` value in either MB or KB by adding either 'M' or 'K' to the value. The letter is case-insensitive, and the default is kilobytes. For example, a one megabyte buffer can be specified in any of these ways:

- `DRDA_COMMBUFFSIZE 1M`
- `DRDA_COMMBUFFSIZE 1m`
- `DRDA_COMMBUFFSIZE 1024K`
- `DRDA_COMMBUFFSIZE 1024k`

- DRDA_COMMBUFFSIZE 1024

DRAUTO configuration parameter

Use the DRAUTO configuration parameter to determine how a secondary database server reacts to a primary server failure.

This parameter should have the same value on both the primary and any secondary servers.

onconfig.std *value*
0

range of values

0 signifies OFF = Disable automatic failover.

1 signifies RETAIN_TYPE = Automatically switch the HDR secondary to standard when the primary server fails. Switch back to HDR secondary when restarting the high-availability cluster.

2 signifies REVERSE_TYPE = Automatically switch the HDR secondary to primary when the primary server fails. Switch to primary (and switch original primary to secondary) when restarting the high-availability cluster.

3 signifies that the Connection Manager performs the role of failover arbitrator.

takes effect

When shared memory is initialized

utilities

onstat (See “**onstat -g dri** command: Print high-availability data replication information” on page 21-81.)

The value you set for DRAUTO determines whether to use the built-in Informix failover arbitrator or to use the Connection Manager as the failover arbitrator. Set DRAUTO to 0 to disable automatic failover. Setting DRAUTO to 1 or 2 configures Informix to use the built-in Informix failover mechanism, which causes Informix to fail over to an HDR secondary server if the primary server fails. Setting DRAUTO to 3 allows the Connection Manager to serve as the failover arbitrator.

If the DRAUTO configuration parameter is set to 0 (OFF), and the Connection Manager failover arbitrator is not enabled, the HDR secondary database server remains a secondary database server in read-only mode when a failure of the primary server occurs.

If the DRAUTO configuration parameter is set to either 1 (RETAIN_TYPE) or 2 (REVERSE_TYPE), the HDR secondary database server automatically switches to standard (for RETAIN_TYPE) or to primary (for REVERSE_TYPE) when a failure of the primary server is detected. If the DRAUTO configuration parameter is set to RETAIN_TYPE, the original secondary database server switches back to type secondary when the HDR connection is restored. If the DRAUTO configuration parameter is set to REVERSE_TYPE, the original secondary database server switches to type primary when the HDR connection is restored, and the original primary switches to type secondary.

Setting the DRAUTO configuration parameter to 3 prevents the possibility of having multiple primary servers within a high-availability cluster. If an attempt is made to bring a server on line as a primary server and DRAUTO=3, then the

Connection Manager verifies that there are no other active primary servers in the cluster. If another primary server is active, then the Connection Manager will reject the request. The server will be unavailable until the Connection Manager is enabled.

You should configure only one failover arbitrator; either the built-in Informix failover arbitrator or the Connection Manager. You should not set DRAUTO to 1 or 2 if you have configured failover using the Connection Manager.

Attention: Use this parameter carefully. A network failure (that is, when the primary database server does not really fail, but the secondary database server perceives network slowness as an HDR failure) can cause the two database servers to become out of synch.

DRIDXAUTO Configuration Parameter

Use the DRIDXAUTO configuration parameter to specify whether the primary High-Availability Data Replication (HDR) server automatically starts index replication if the secondary HDR server detects a corrupted index.

onconfig.std *value*
0

range of values

0 = Off

1 = On

utilities

onstat (See “**onstat -g dri** command: Print high-availability data replication information” on page 21-81.)

takes effect

When the database server is shut down and restarted

To alter the value of the DRIDXAUTO configuration parameter for an active server instance, use the **onmode -d idxauto** command. You do not need to restart the server instance. However, the **onmode -d idxauto** command will not change the value of the DRIDXAUTO configuration parameter in the ONCONFIG file. For more information, see “**onmode -d** command: Replicate an index with data-replication” on page 15-11.

DRINTERVAL configuration parameter

Use the DRINTERVAL configuration parameter to specify the maximum interval, in seconds, between flushing the high-availability data-replication buffer.

onconfig.std *value*
30

units Seconds

range of values

-1, to update synchronously

0

positive integers

takes effect

After you edit your onconfig file and restart the database server.

When you reset the value dynamically in your `onconfig` file by running the `onmode -wf` command.

When you reset the value for a session by running the `onmode -wm` command.

utilities

onstat (See “`onstat -g dri` command: Print high-availability data replication information” on page 21-81.)

refer to When log records are sent, in the chapter on High-Availability Data Replication in the *IBM Informix Administrator's Guide*

Related reference:

“`onmode -wf, -wm`: Dynamically change certain configuration parameters” on page 15-26

DRLOSTFOUND Configuration Parameter

Use the DRLOSTFOUND configuration parameter to specify the path name to the HDR lost-and-found file. This file indicates that some transactions were committed on the HDR primary database server before that were not committed on the secondary database server when the primary database server experienced a failure.

onconfig.std *value*

On UNIX: `$INFORMIXDIR/etc/dr.lostfound`

On Windows: `$INFORMIXDIR\tmp`

range of values

Pathname

takes effect

When the database server is shut down and restarted

utilities

onstat (See “`onstat -g dri` command: Print high-availability data replication information” on page 21-81.)

refer to Lost-and-found transactions, in the chapter on High-Availability Data Replication in the *IBM Informix Administrator's Guide*

The DRLOSTFOUND configuration parameter is not applicable if updates between the primary and secondary database servers occur synchronously, when the DRINTERVAL configuration parameter is set to -1.

The lost-and-found file, `dr.lostfound.timestamp`, is created with a time stamp that is appended to the filename so that the database server does not overwrite another lost and found file if another file already exists. You cannot use the lost-and-found file to reapply lost transactions.

DRTIMEOUT configuration parameter

Use the DRTIMEOUT configuration parameter to specify the length of time, in seconds, that a database server in a high-availability data-replication pair waits for a transfer acknowledgment from the other database server in the pair. This parameter applies only to high-availability data-replication pairs.

onconfig.std *value*

30

units Seconds

range of values

Positive integers

takes effect

After you edit your onconfig file and restart the database server.

When you reset the value dynamically in your onconfig file by running the **onmode -wf** command.

When you reset the value for a session by running the **onmode -wm** command.

utilities

onstat (See “**onstat -g dri** command: Print high-availability data replication information” on page 21-81.)

refer to How High-Availability Data Replication failures are detected, in the chapter on High-Availability Data Replication in the *IBM Informix Administrator's Guide*

Calculate the value for the DRTIMEOUT configuration parameter

Use the following formula to calculate the value to specify for the DRTIMEOUT configuration parameter:

$$\text{DRTIMEOUT} = \text{wait_time} / 4$$

In this formula, *wait_time* is the length of time, in seconds, that a database server in a high-availability data-replication pair must wait before the server assumes that a high-availability data-replication failure occurred.

For example, you determine that *wait_time* for your system is 160 seconds. Use the preceding formula to set DRTIMEOUT as follows:

$$\text{DRTIMEOUT} = 160 \text{ seconds} / 4 = 40 \text{ seconds}$$

Related reference:

“onmode -wf, -wm: Dynamically change certain configuration parameters” on page 15-26

DS_HASHSIZE Configuration Parameter

Use the DS_HASHSIZE configuration parameter to specify the number of hash buckets in the data-distribution cache. The database server uses the hash buckets to store and access column statistics that the UPDATE STATISTICS statement generates in the MEDIUM or HIGH mode.

Use the DS_HASHSIZE and DS_POOLSIZE configuration parameters to improve the performance of frequently used queries in a multiuser environment.

onconfig.std *value*

31

units Number of hash buckets or lists

range of values

Any positive integer; a prime number is recommended

takes effect

When the database server is shut down and restarted

refer to

- *IBM Informix Performance Guide* for how to monitor and tune the data-distribution cache
- “DS_POOLSIZ Configuration Parameter” on page 1-64

For information on configuration parameters for UDR cache, see the “PC_HASHSIZE Configuration Parameter” on page 1-112 and the “PC_POOLSIZ Configuration Parameter” on page 1-112.

DS_MAX_QUERIES configuration parameter

Use the DS_MAX_QUERIES configuration parameter to specify the maximum number of parallel database queries (PDQ) that can run concurrently.

The value of the DS_MAX_QUERIES configuration parameter is dependent on the setting for the DS_TOTAL_MEMORY configuration parameter:

- If the DS_TOTAL_MEMORY configuration parameter is set, then the value of the DS_MAX_QUERIES is $DS_TOTAL_MEMORY / 128$, rounded down to the nearest integer value.
- If the DS_TOTAL_MEMORY configuration parameter is not set, then the value of the DS_MAX_QUERIES configuration parameter is $2 * num$, where num is the number of CPUs specified in the VPCLASS configuration parameter.

onconfig.std *value*

None

if not present

$2 * num * 128$, where num is the number of CPUs specified in the VPCLASS configuration parameter.

units Number of queries

range of values

Minimum value = 1

Maximum value = 8,388,608 (8 megabytes)

utilities

onmode -Q (See “onmode -D, -M, -Q, -S: Change decision-support parameters” on page 15-12.)

onstat -g mgm (See “onstat -g mgm command: Print MGM resource information” on page 21-116.)

takes effect

After you edit your onconfig file and restart the database server.

When you reset the value dynamically in your onconfig file by running the **onmode -wf** command.

When you reset the value for a session by running the **onmode -wm** command.

refer to

- “VPCLASS configuration parameter” on page 1-167
- Parallel database query in your *IBM Informix Performance Guide*

Usage

The Memory Grant Manager (MGM) reserves memory for a query based on the following formula:

$$\text{memory_reserved} = \text{DS_TOTAL_MEMORY} * \frac{(\text{PDQ-priority} / 100) * (\text{MAX_PDQPRIORITY} / 100)}$$

The value of PDQPRIORITY is specified in either the **PDQPRIORITY** environment variable or the SQL statement SET PDQPRIORITY.

Related reference:

“onmode -wf, -wm: Dynamically change certain configuration parameters” on page 15-26

 [PDQPRIORITY environment variable \(SQL Reference\)](#)

DS_MAX_SCANS configuration parameter

Use the DS_MAX_SCANS configuration parameter to limit the number of PDQ scan threads that the database server can execute concurrently.

onconfig.std *value*

1048576 or (1024 * 1024)

units Number of PDQ scan threads

range of values

10 through (1024 * 1024)

utilities

onmode -S (see “onmode -D, -M, -Q, -S: Change decision-support parameters” on page 15-12.) **onstat -g mgm** (See “onstat -g mgm command: Print MGM resource information” on page 21-116.)

takes effect

After you edit your onconfig file and restart the database server.

When you reset the value dynamically in your onconfig file by running the **onmode -wf** command.

When you reset the value for a session by running the **onmode -wm** command.

refer to Parallel database query in your *IBM Informix Performance Guide*

Usage

When a user issues a query, the database server apportions some number of scan threads, depending on the following values:

- The value of PDQ priority (set by the environment variable **PDQPRIORITY** or the SQL statement SET PDQPRIORITY)
- The ceiling that you set with DS_MAX_SCANS
- The factor that you set with MAX_PDQPRIORITY
- The number of fragments in the table to scan (*nfrags* in the formula)

The Memory Grant Manager (MGM) tries to reserve scan threads for a query according to the following formula:

$$\text{reserved_threads} = \min(\text{nfrags}, (\text{DS_MAX_SCANS} * \frac{\text{PDQPRIORITY} / 100 * (\text{MAX_PDQPRIORITY} / 100)}{100}))$$

If the DS_MAX_SCANS part of the formula is greater than or equal to the number of fragments in the table to scan, the query is held in the ready queue until as

many scan threads are available as there are table fragments. Once underway, the query executes quickly because threads are scanning fragments in parallel.

For example, if *nfrags* equals 24, *DS_MAX_SCANS* equals 90, *PDQPRIORITY* equals 50, and *MAX_PDQPRIORITY* equals 60, the query does not begin execution until *nfrags* scan threads are available. Scanning takes place in parallel.

If the *DS_MAX_SCANS* formula falls below the number of fragments, the query might begin execution sooner, but the query takes longer to execute because some threads scan fragments serially.

If you reduce *DS_MAX_SCANS* to 40 in the previous example, the query needs fewer resources (12 scan threads) to begin execution, but each thread needs to scan two fragments serially. Execution takes longer.

Related reference:

“onmode -wf, -wm: Dynamically change certain configuration parameters” on page 15-26

 [PDQPRIORITY environment variable \(SQL Reference\)](#)

DS_NONPDQ_QUERY_MEM configuration parameter

Use the *DS_NONPDQ_QUERY_MEM* configuration parameter to increase the amount of memory that is available for a query that is not a Parallel Database Query (PDQ). (You can only use this parameter if PDQ priority is set to zero.)

onconfig.std

128

units Kilobytes

range of values

From 128 Kilobytes to 25 percent of the value of *DS_TOTAL_MEMORY*

takes effect

After you edit your *onconfig* file and restart the database server.

When you reset the value dynamically in your *onconfig* file by running the **onmode -wf** command.

When you reset the value for a session by running the **onmode -wm** command.

utilities

onstat -g mgm (See “**onstat -g mgm** command: Print MGM resource information” on page 21-116.)

If you specify a value for the *DS_NONPDQ_QUERY_MEM* parameter, determine and adjust the value based on the number and size of table rows.

Tip: Set the value to generally not exceed the largest available temporary dbspace size.

The *DS_NONPDQ_QUERY_MEM* value is calculated during database server initialization based on the calculated *DS_TOTAL_MEMORY* value. If during the processing of the *DS_NONPDQ_QUERY_MEM*, the database server changes the value that you set, the server sends a message in this format:

DS_NONPDQ_QUERY_MEM recalculated and changed from *old_value* Kb to *new_value* Kb.

In the message, *old_value* represents the value that you assigned to DS_NONPDQ_QUERY_MEM in the user configuration file, and *new_value* represents the value determined by the database server.

Related reference:

“onmode -wf, -wm: Dynamically change certain configuration parameters” on page 15-26

DS_POOLSIZE Configuration Parameter

onconfig.std *value*
127

default value
127

units Maximum number of entries in the data-distribution cache

range of values
Any positive value from 127 to *x*, where *x* is dependent upon the shared memory configuration and available shared memory for the server instance.

takes effect
When the database server is shut down and restarted

refer to

- *IBM Informix Performance Guide* for how to monitor and tune the data-distribution cache
- “DS_HASHSIZE Configuration Parameter” on page 1-60

The DS_POOLSIZE parameter specifies the maximum number of entries in each hash bucket in the data-distribution cache that the database server uses to store and access column statistics that the UPDATE STATISTICS statement generates in the MEDIUM or HIGH mode.

Use DS_HASHSIZE and DS_POOLSIZE to improve performance of frequently executed queries in a multi-user environment.

For information on configuration parameters for UDR cache, see “PC_HASHSIZE Configuration Parameter” on page 1-112 and “PC_POOLSIZE Configuration Parameter” on page 1-112.

DS_TOTAL_MEMORY configuration parameter

Use the DS_TOTAL_MEMORY configuration parameter to specify the amount of memory available for PDQ queries. The amount should be smaller than the computer physical memory, minus fixed overhead such as operating-system size and buffer-pool size.

onconfig.std *value*
None

if not present

If SHMTOTAL=0 and DS_MAX_QUERIES is set, DS_TOTAL_MEMORY = DS_MAX_QUERIES * 128.

If SHMTOTAL=0 and DS_MAX_QUERIES is not set, DS_TOTAL_MEMORY = num_cpu_vps * 2 * 128.

units Kilobytes

range of values

If DS_MAX_QUERY is set, the minimum value is DS_MAX_QUERY * 128.

If DS_MAX_QUERY is not set, the minimum value is num_cpu_vps * 2 * 128.

There is no maximum value limit other than any limit that you might have with the software that you use on your machine.

utilities

onmode -M (see “onmode -D, -M, -Q, -S: Change decision-support parameters” on page 15-12.) **onstat -g mgm** (See “onstat -g mgm command: Print MGM resource information” on page 21-116.)

takes effect

After you edit your onconfig file and restart the database server.

When you reset the value dynamically in your onconfig file by running the **onmode -wf** command.

When you reset the value for a session by running the **onmode -wm** command.

Usage

Do not confuse DS_TOTAL_MEMORY with the configuration parameters SHMTOTAL and SHMVIRTSIZE. SHMTOTAL specifies all the memory for the database server (total of the resident, virtual, and message portions of memory). SHMVIRTSIZE specifies the size of the virtual portion. DS_TOTAL_MEMORY is part of SHMVIRTSIZE.

For OLTP applications, set DS_TOTAL_MEMORY to between 20 and 50 percent of the value of SHMTOTAL in kilobytes.

For applications that involve large decision-support (DSS) queries, increase the value of DS_TOTAL_MEMORY to between 50 and 80 percent of SHMTOTAL. If you use your database server for DSS queries exclusively, set this parameter to 90 and 100 percent of SHMTOTAL.

Set the DS_TOTAL_MEMORY configuration parameter to any value not greater than the quantity (SHMVIRTSIZE - 10 megabytes).

For information on the maximum memory available on your platform, see the machine notes

Related concepts:

 Algorithm for determining DS_TOTAL_MEMORY (Performance Guide)

Related reference:

“onmode -wf, -wm: Dynamically change certain configuration parameters” on page 15-26

“SHMTOTAL configuration parameter” on page 1-137

“SHMVIRTSIZE configuration parameter” on page 1-139

“VPCLASS configuration parameter” on page 1-167

Algorithm for DS_TOTAL_MEMORY

The database server derives a value for DS_TOTAL_MEMORY when you do not set DS_TOTAL_MEMORY, or if you set it to an inappropriate value. For information on the algorithms, see configuration effects on memory utilization in your *IBM Informix Performance Guide*.

DUMPCNT configuration parameter (UNIX)

Use the DUMPCNT configuration parameter to specify the number of assertion failures for which one database server thread dumps shared memory or generates a core file by calling **gcore**.

onconfig.std *value*

1

if not present

1

units Number of assertion failures

range of values

Positive integers

takes effect

After you edit your onconfig file and restart the database server.

When you reset the value dynamically in your onconfig file by running the **onmode -wf** command.

When you reset the value for a session by running the **onmode -wm** command.

refer to

- Collecting diagnostic information in the chapter on consistency checking in the *IBM Informix Administrator's Guide*
- “DUMPDIR Configuration Parameter” on page 1-67
- “DUMPSHMEM configuration parameter (UNIX)” on page 1-68

An assertion is a test of some condition or expression with the expectation that the outcome is true. For example, the following statement illustrates the concept of an assertion failure:

```
if (a != b)
    assert_fail("a != b");
```

Related reference:

“onmode -wf, -wm: Dynamically change certain configuration parameters” on page 15-26

DUMPCORE Configuration Parameter (UNIX)

onconfig.std value

0

range of values

0 = Do not dump core image. 1 = Dump core image.

takes effect

When the database server is shut down and restarted

refer to Collecting diagnostic information in the chapter on consistency checking in the *IBM Informix Administrator's Guide*

DUMPCORE controls whether assertion failures cause a virtual processor to dump a core image. The core file is left in the directory from which the database server was last invoked. (The DUMPDIR parameter has no impact on the location of the core file.)

Warning: When *DUMPCORE* is set to 1, an assertion failure causes a virtual processor to dump a core image, which in turn causes the database server to abort. Set *DUMPCORE* only for debugging purposes in a controlled environment.

DUMPDIR Configuration Parameter

onconfig.std value

On UNIX: `$INFORMIXDIR/tmp` On Windows: `$INFORMIXDIR\tmp`

if not present

`$INFORMIXDIR/tmp`

range of values

Any directory to which user **informix** has write access

takes effect

When the database server is shut down and restarted

refer to

- Collecting diagnostic information in the chapter on consistency checking in the *IBM Informix Administrator's Guide*
- “DUMPCNT configuration parameter (UNIX)” on page 1-66
- “DUMPSHMEM configuration parameter (UNIX)” on page 1-68

DUMPDIR specifies a directory in which the database server dumps shared memory, **gcore** files, or messages from a failed assertion. Because shared memory can be large, set DUMPDIR to a file system with a significant amount of space. The directory to which DUMPDIR is set must exist for the server to start.

DUMPGCORE Configuration Parameter (UNIX)

onconfig.std value

0

range of values

0 = Do not dump **gcore**. 1 = Dump **gcore**.

takes effect

When the database server is shut down and restarted

refer to Collecting diagnostic information in the chapter on consistency checking in the *IBM Informix Administrator's Guide*

DUMPGCORE is used with operating systems that support **gcore**. If you set DUMPGCORE, but your operating system does not support **gcore**, messages in the database server message log indicate that an attempt was made to dump a core image, but the database server cannot find the expected file. (If your operating system does not support **gcore**, set DUMPCORE instead.)

If DUMPGCORE is set, the database server calls **gcore** whenever a virtual processor encounters an assertion failure. The **gcore** utility directs the virtual processor to dump a core image to the **core.pid.cnt** file in the directory that DUMPPDIR specifies and continue processing.

The **pid** value is the process identification number of the virtual processor. The **cnt** value is incremented each time that this process encounters an assertion failure. The **cnt** value can range from 1 to the value of DUMPCNT. After that, no more core files are created. If the virtual processor continues to encounter assertion failures, errors are reported to the message log (and perhaps to the application), but no further diagnostic information is saved.

DUMPSHMEM configuration parameter (UNIX)

Use the DUMPSHMEM configuration parameter to indicate whether a shared memory dump is created on an assertion failure. This configuration parameter also specifies how much memory is written to the **shmem.pid.cnt** file in the directory specified by the DUMPPDIR configuration parameter.

onconfig.std *value*

1

range of values

0 = Do not create a shared memory dump.

1 = Create a shared memory dump of all the shared memory that the database uses.

2 = Create a shared memory dump that excludes the buffer pool in the resident memory,

takes effect

When the database server is shut down and restarted

takes effect

After you edit your **onconfig** file and restart the database server.

When you reset the value dynamically in your **onconfig** file by running the **onmode -wf** command.

When you reset the value for a session by running the **onmode -wm** command.

refer to

- Collecting diagnostic information in the chapter on consistency checking in the *IBM Informix Administrator's Guide*

- “**onstat -o** command: Output shared memory contents to a file” on page 21-198
- “Running **onstat** Commands on a Shared Memory Dump File” on page 21-24
- “DUMPCNT configuration parameter (UNIX)” on page 1-66
- “DUMPPDIR Configuration Parameter” on page 1-67

Usage

If DUMPSHMEM is set to 1, all the shared memory that the database server uses is dumped, which can result in a large file. When space is limited, set DUMPSHMEM to 2 because this setting creates a smaller shared-memory dump file.

The *pid* value is the process identification number for the virtual processor. The *cnt* value increments each time that this virtual processor encounters an assertion failure. The *cnt* value can range from 1 to the value of the DUMPCNT configuration parameter. After the value of DUMPCNT is reached, no more files are created. If the database server continues to detect inconsistencies, errors are reported to the message log (and perhaps to the application), but no further diagnostic information is saved.

Related reference:

“onmode -wf, -wm: Dynamically change certain configuration parameters” on page 15-26

DYNAMIC_LOGS configuration parameter

Specifies whether the dynamic log file allocation feature is off, on, or causes the database server to pause to allow the manual addition of a logical log file.

onconfig.std *value*
2

if not present
2 (Default)

range of values

0 = Turn off dynamic-log allocation.

1 = Set off the “log file required” alarm and pause to allow manual addition of a logical-log file. You can add a log file immediately after the current log file or to the end of the log file list.

2 = Turn on dynamic-log allocation. When the database server dynamically adds a log file, it sets off the “dynamically added log file” alarm.

takes effect

For HDR: when the database server is shut down and restarted

For Enterprise Replication: when Enterprise Replication is started

When you reset the value dynamically in your onconfig file by running the **onmode -wf** command.

When you reset the value for a session by running the **onmode -wm** command.

utilities

“onparams -a -d *dbspace*: Add a logical-log file” on page 17-2

refer to

- Information about logical logs in the *IBM Informix Administrator's Guide*

If DYNAMIC_LOGS is 2, the database server automatically allocates a new log file when the next active log file contains an open transaction. Dynamic-log allocation prevents long transaction rollbacks from hanging the system.

If you want to choose the size and location of the new logical-log file, set DYNAMIC_LOGS to 1. Use the **onparams -a** command with the size (**-s**), location (**-d dbspace**), and **-i** options to add a log file after the current log file.

Even when DYNAMIC_LOGS is turned off, you do not have the same risks as in previous database server versions. In Version 9.3 and later, if the database server hangs from a long transaction rollback, you can shut down the database server, set DYNAMIC_LOGS to 1 or 2, and then restart the database server.

Important: If you are using *Enterprise Replication* with dynamic log allocation, set *LTXEHWM* to no higher than 70.

Related reference:

“onmode -wf, -wm: Dynamically change certain configuration parameters” on page 15-26

“LTXEHWM configuration parameter” on page 1-93

“LTXHWM configuration parameter” on page 1-94

EILSEQ_COMPAT_MODE configuration parameter

Use the EILSEQ_COMPAT_MODE configuration parameter to control if Informix checks whether character data inserted by a client application contains code point sequences not recognized by the current locale.

onconfig.std *value*

0

if not present value

0

range of values

0 = Informix validates incoming character sequences with the current locale and returns error -202 if any characters are not valid.

1 = Informix does not validate incoming character sequences.

takes effect

When the database server is shut down and restarted

For example, if the EILSEQ_COMPAT_MODE configuration parameter is set to 0, an ESQL/C program that attempts to execute the following SQL statement on a database created with the **DB_LOCALE** environment variable set to **en_US.utf8** receives error -202 because the sequence 0x369 is not a valid byte sequence in UTF-8:

```
INSERT INTO x (columnA) VALUES '\x03\x69|data';
```

If you are using UTF-8 databases, set the **GL_USEGLU** environment variable to 1 on the client to enable the server to recognize a wider range of Unicode characters instead of setting the EILSEQ_COMPAT_MODE configuration parameter to 1 to prevent errors.

ENABLE_SNAPSHOT_COPY configuration parameter

Use the ENABLE_SNAPSHOT_COPY configuration parameter to enable or disable the ability to clone a server using the **ifxclone** utility.

The ENABLE_SNAPSHOT_COPY configuration parameter determines whether you can create a clone of a server using the **ifxclone** utility. Set the ENABLE_SNAPSHOT_COPY configuration parameter to 1 to allow cloning. Set the value to 0 to prohibit cloning the server using the **ifxclone** utility.

onconfig.std value
None

if not present
0 (Do not allow the server to be cloned)

range of values
0, 1 (0 = prohibit clone, 1 = permit clone)

takes effect

After you edit your onconfig file and restart the database server.

When you reset the value dynamically in your onconfig file by running the **onmode -wf** command.

When you reset the value for a session by running the **onmode -wm** command.

Related reference:

“onmode -wf, -wm: Dynamically change certain configuration parameters” on page 15-26

Chapter 19, “The ifxclone utility,” on page 19-1

ENCRYPT_CIPHERS Configuration Parameter

Use the ENCRYPT_CIPHERS configuration parameter to define all ciphers and modes that can be used by the current database session. ENCRYPT_CIPHERS is used for Enterprise Replication and High-Availability Data Replication only.

onconfig.std value
Not set. Encryption ciphers are not used.

values See the Usage section.

takes effect

After you edit your onconfig file and restart the database server.

Usage

The encryption cipher and mode used is randomly chosen among the ciphers common between the two servers. If a specific cipher is discovered to have a weakness, you should reset the ENCRYPT_CIPHERS configuration parameter value to eliminate that cipher by using the **allbut** option.

Important: Including all ciphers is more secure than including specific ciphers.

Syntax for the ENCRYPT_CIPHERS configuration parameter

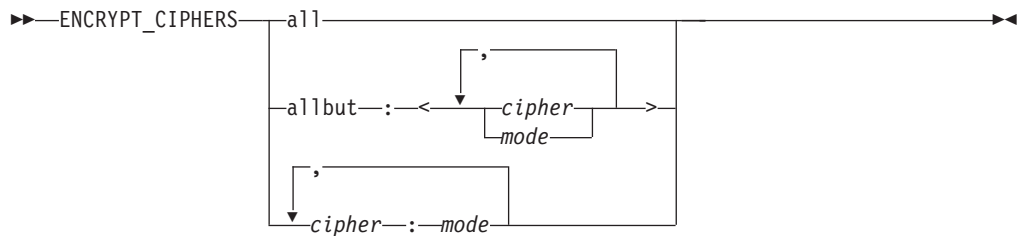



Table 1-59. Options for the ENCRYPT_CIPHERS configuration parameter value

Field	Description
all	<p>Include all available ciphers and modes, except ECB mode, which is considered weak.</p> <p>For example: ENCRYPT_CIPHERS all</p>
allbut	<p>Include all ciphers and modes, except ECB and the ciphers and modes listed.</p> <p>For example: ENCRYPT_CIPHERS allbut:<cbc,bf></p> <p>The cipher list can include unique, abbreviated entries. For example, bf can represent bf-1, bf-2, and bf-3; however, if the abbreviation is the name of an actual cipher, then only that cipher is eliminated. Therefore, des eliminates only the des cipher, but de eliminates the des, des3, and desx ciphers.</p>
<i>cipher</i>	<p>The following ciphers are supported:</p> <ul style="list-style-type: none"> • des = DES (64-bit key) • des3 = Triple DES • desx = Extended DES (128-bit key). Only supports cbc mode. • aes = AES 128bit key • aes192 = AES 192bit key • bf-1 = Blow Fish (64-bit key) • bf-2 = Blow Fish (128-bit key) • bf-3 = Blow Fish (192-bit key) • aes128 = AES 128bit key • aes256 = AES 256bit key <p>All modes are supported for all ciphers, except the desx cipher.</p> <p>For an updated list of supported ciphers, see the Release Notes.</p>
<i>mode</i>	<p>The following modes are supported:</p> <ul style="list-style-type: none"> • ecb = Electronic Code Book (ECB). Only included if specified. • cbc = Cipher Block Chaining • cfb = Cipher Feedback • ofb = Output Feedback

Related tasks:

-  [Encrypting data traffic between HDR database servers \(Administrator's Guide\)](#)
-  [Setting Configuration Parameters \(Enterprise Replication\)](#)

Related reference:

- [“ENCRYPT_HDR Configuration Parameter”](#)
- [“ENCRYPT_MAC Configuration Parameter”](#)
- [“ENCRYPT_MACFILE configuration parameter” on page 1-74](#)
- [“ENCRYPT_SWITCH configuration parameter” on page 1-76](#)

ENCRYPT_HDR Configuration Parameter

onconfig.std value
None

range of values
0 = Disables HDR encryption
1 = Enables HDR encryption

takes effect
when the server is initialized

refer to

- [“ENCRYPT_CIPHERS Configuration Parameter” on page 1-71](#)
- [“ENCRYPT_MAC Configuration Parameter”](#)
- [“ENCRYPT_MACFILE configuration parameter” on page 1-74](#)
- [“ENCRYPT_SWITCH configuration parameter” on page 1-76](#)
- HDR Encryption Options in the *IBM Informix Administrator's Guide*
- Using High-Availability Data Replication in the IBM Informix Enterprise Replication

ENCRYPT_HDR enables or disables HDR encryption. Enabling HDR encryption provides a secure method for transferring data from one server to another in an HDR pair. HDR encryption works in conjunction with Enterprise Replication (ER) encryption. However, it is not necessary to have ER encryption enabled for HDR encryption. HDR encryption works whether ER encryption is enabled or not. HDR and ER share the same encryption configuration parameters: ENCRYPT_CIPHERS, ENCRYPT_MAC, ENCRYPT_MACFILE and ENCRYPT_SWITCH.

Related reference:

- [“ENCRYPT_CIPHERS Configuration Parameter” on page 1-71](#)

ENCRYPT_MAC Configuration Parameter

Use the ENCRYPT_MAC configuration parameter to control the level of message authentication code (MAC) generation. This configuration parameter is used only for Enterprise Replication and High-Availability Data Replication.

onconfig.std value
None

range of values
One or more of the following options, separated by commas:

Option	Description
off	Does not use MAC generation
low	Uses XOR folding on all messages
medium	Uses SHA1 MAC generation for all messages that are greater than 20 bytes long and XOR folding on smaller messages
high	Uses SHA1 MAC generation on all messages.

example

ENCRYPT_MAC medium,high

takes effect

For HDR: when the database server is shut down and restarted

For Enterprise Replication: when Enterprise Replication is started

refer to

- “ENCRYPT_CIPHERS Configuration Parameter” on page 1-71
- “ENCRYPT_HDR Configuration Parameter” on page 1-73
- “ENCRYPT_MACFILE configuration parameter”
- “ENCRYPT_SWITCH configuration parameter” on page 1-76
- HDR Encryption Options in the *IBM Informix Administrator’s Guide*
- Using High-Availability Data Replication in the IBM Informix Enterprise Replication

The level is prioritized to the highest value. For example, if one node has a level of **high** and **medium** enabled and the other node has only **low** enabled, then the connection attempt fails. Use the **off** entry between servers only when a secure network connection is guaranteed.

Related reference:

“ENCRYPT_CIPHERS Configuration Parameter” on page 1-71

ENCRYPT_MACFILE configuration parameter

Use the ENCRYPT_MACFILE configuration parameter to specify a list of the full path names of MAC key files. This configuration parameter is used only for Enterprise Replication and High-Availability Data Replication.

onconfig.std *value*

None

units pathnames, up to 1536 bytes in length

range of values

One or more full path and filenames separated by commas, and the optional **builtin** keyword. For example: ENCRYPT_MACFILE /usr/local/bin/mac1.dat, /usr/local/bin/mac2.dat,builtin

takes effect

For HDR: when the database server is shut down and restarted.

For Enterprise Replication: when Enterprise Replication is started.

refer to

- “ENCRYPT_CIPHERS Configuration Parameter” on page 1-71

- “ENCRYPT_HDR Configuration Parameter” on page 1-73
- “ENCRYPT_MAC Configuration Parameter” on page 1-73
- “ENCRYPT_SWITCH configuration parameter” on page 1-76
- HDR Encryption Options in the *IBM Informix Administrator’s Guide*
- Using High-Availability Data Replication in the IBM Informix Enterprise Replication guide

Each of the entries for the ENCRYPT_MACFILE configuration parameter is prioritized and negotiated at connect time. The prioritization for the MAC key files is based on their creation time by the **GenMacKey** utility. The entry created from the **builtin** keyword has the lowest priority. Because the MAC key files are negotiated, you should periodically change the keys.

Specify the builtin keyword

Use the **builtin** keyword to specify the built-in key. The **builtin** keyword provides limited message verification (some validation of the received message and determination that it appears to have come from an Informix client or server). The strongest verification is done by a site-generated MAC key file.

Generate a MAC key file

1. Execute the following command from the command line:
GenMacKey -o filename
The *filename* is the name of the MAC key file.
2. Update the ENCRYPT_MACFILE configuration parameter on participating servers to include the location of the new MAC key file.
3. Distribute the new MAC key file.

Related reference:

“ENCRYPT_CIPHERS Configuration Parameter” on page 1-71

ENCRYPT_SMX Configuration Parameter

Use the ENCRYPT_SMX configuration parameter to set the level of encryption for high-availability configurations on secondary servers.

onconfig.std *value*

None

range of values

Value	Explanation
0	Off. Do not encrypt.
1	On. Encrypt where possible. Encrypt SMX transactions when the database server being connected to also supports encryption.
2	On. Always encrypt. Only connections to encrypted database servers are allowed.

takes effect

When the server is restarted

refer to

- Server Multiplexer group (SMX) Connections in the *IBM Informix Administrator’s Guide*

- Using High-Availability Data Replication in the IBM Informix Enterprise Replication guide

ENCRYPT_SWITCH configuration parameter

Use the ENCRYPT_SWITCH configuration parameter to define the frequency at which ciphers or secret keys are renegotiated. This configuration parameter is used only for Enterprise Replication and High-Availability Data Replication.

The longer the secret key and encryption cipher remains in use, the more likely the encryption rules might be broken by an attacker. To avoid this, cryptologists recommend changing the secret keys on long-term connections. The default time that this renegotiation occurs is once an hour.

onconfig.std *value*
None

syntax ENCRYPT_SWITCH *cipher_switch_time*, *key_switch_time*

- *cipher_switch_time* specifies the minutes between cipher renegotiation
- *key_switch_time* specifies the minutes between secret key renegotiation

units minutes

range of values
positive integers

takes effect

For HDR: when the database server is shut down and restarted

For Enterprise Replication: when Enterprise Replication is started

refer to

- “ENCRYPT_CIPHERS Configuration Parameter” on page 1-71
- “ENCRYPT_HDR Configuration Parameter” on page 1-73
- “ENCRYPT_MAC Configuration Parameter” on page 1-73
- “ENCRYPT_MACFILE configuration parameter” on page 1-74
- HDR Encryption Options in the *IBM Informix Administrator’s Guide*
- Using High-Availability Data Replication in the IBM Informix Enterprise Replication guide

Related reference:

“ENCRYPT_CIPHERS Configuration Parameter” on page 1-71

EXPLAIN_STAT Configuration Parameter

Use the EXPLAIN_STAT configuration parameter to enable or disable the inclusion of a Query Statistics section in the explain output file.

You can generate the output file by using either the SET EXPLAIN statement or the **onmode -Y sessionid** command. When you enable the EXPLAIN_STAT configuration parameter, the Query Statistics section shows the estimated number of rows and the actual number of returned rows in the Query Plan.

onconfig.std *value*
1

range of values
0 = Disable the inclusion of a Query Statistics section in the explain output file.

1 = Enable the inclusion of a Query Statistics section in the explain output file.

takes effect

After you edit your onconfig file and restart the database server.

When you reset the value dynamically in your onconfig file by running the **onmode -wf** command.

When you reset the value for a session by running the **onmode -wm** command.

refer to

- “onmode -Y: Dynamically change SET EXPLAIN” on page 15-29
- SET EXPLAIN, in the *IBM Informix Guide to SQL: Syntax*
- Query Plan Report, in the *IBM Informix Performance Guide*

Value	Description
0	Disables the display of query statistics.
1	Enables the display of query statistics.

Related reference:

“onmode -wf, -wm: Dynamically change certain configuration parameters” on page 15-26

EXT_DIRECTIVES Configuration Parameter

onconfig.std *value*
0

range of values
0, 1, 2

takes effect

When the database server is shut down and restarted

environment variable

IFX_EXTDIRECTIVES

refer to

- Environment variables and information about the **sysdirectives** system catalog table, in the *IBM Informix Guide to SQL: Reference*
- Query optimizer directives, in the *IBM Informix Guide to SQL: Syntax*
- SET ENVIRONMENT EXTDIRECTIVES statement of SQL, in the *IBM Informix Guide to SQL: Syntax*
- Using external optimizer directives, in the *IBM Informix Performance Guide*

The EXT_DIRECTIVES configuration parameter enables or disables the use of external query optimizer directives. Enable external directives by using the EXT_DIRECTIVES configuration parameter in combination with the client-side IFX_EXTDIRECTIVES environment variable as follows:

Value	Explanation
0 (default)	Off. The directive cannot be enabled even if IFX_EXTDIRECTIVES is on.

Value	Explanation
1	On. The directive can be enabled for a session if IFX_EXTDIRECTIVES is on.
2	On. The directive can be used even if IFX_EXTDIRECTIVES is not set.

The setting of the **IFX_EXTDIRECTIVES** environment variable overrides the setting of the **EXT_DIRECTIVES** configuration parameter. If you do not set the **IFX_EXTDIRECTIVES** environment variable, all sessions for a client inherit the database server configuration for processing external directives.

The setting specified by the **SET ENVIRONMENT EXTDIRECTIVES** statement of SQL overrides (for the current user session only) the settings of both the **IFX_EXTDIRECTIVES** environment variable and of the **EXT_DIRECTIVES** configuration parameter.

Related tasks:

[EXTDIRECTIVES Environment Option \(SQL Syntax\)](#)

Related reference:

[IFX_EXTDIRECTIVES environment variable \(SQL Reference\)](#)

EXTSHMADD configuration parameter

Use the **EXTSHMADD** configuration parameter to specify the size of virtual-extension segments that are added when a user-defined routine or a DataBlade routine is run in a user-defined virtual processor.

onconfig.std value

EXTSHMADD 8192

values 32-bit operating systems: 1024 - 524288

64-bit operating systems: 1024 - 4294967296

units KB

takes effect

After you edit your **onconfig** file and restart the database server.

Usage

When a thread is run in a user defined virtual processor, a virtual-extension segment is created. In the output of the **onstat -g seg** command, the virtual-extension segment has a class of **VX**. If the **EXTSHMADD** configuration parameter is not set in the **onconfig** file, the size of virtual-extension segments is set by the value of the **SHMADD** configuration parameter.

Related concepts:

 Virtual-extension portion of shared memory (Administrator's Guide)

Related reference:

“**onstat -g seg** command: Print shared memory segment statistics” on page 21-161

“SHMADD configuration parameter” on page 1-135

FAILOVER_CALLBACK Configuration Parameter

onconfig.std value

None

default value

None

range of values

Pathname

takes effect

When the database server is shut down and restarted

The database server executes the script specified by `FAILOVER_CALLBACK` when a database server transitions from a secondary server to a primary or standard server. Set `FAILOVER_CALLBACK` to the full pathname of the script.

FAILOVER_TX_TIMEOUT configuration parameter

In high-availability cluster environments, use the `FAILOVER_TX_TIMEOUT` configuration parameter to enable transactions to complete after failover of the primary server.

Use the `FAILOVER_TX_TIMEOUT` configuration parameter to indicate the maximum number of seconds after failover that the server waits before rolling back transactions. Set the `FAILOVER_TX_TIMEOUT` configuration parameter to the same value on all servers in a high-availability cluster.

onconfig.std value

0

syntax `FAILOVER_TX_TIMEOUT seconds`

takes effect

After you edit your `onconfig` file and restart the database server.

When you reset the value dynamically in your `onconfig` file by running the **onmode -wf** command.

When you reset the value for a session by running the **onmode -wm** command.

by default

Transaction survival is disabled by default.

When a failover occurs in a high-availability cluster environment, one of the secondary servers takes over the role of the primary server. The secondary server that becomes the new primary server is called the *failover server*.

You enable transaction survival by setting the `FAILOVER_TX_TIMEOUT` configuration parameter to a value greater than zero. When transaction survival is enabled, the failover server must be able to contact the remaining secondary

servers to synchronize and resume any open transactions. Similarly, the surviving secondary servers must be able to establish connections to the failover server to re-send any pending transactions. The `FAILOVER_TX_TIMEOUT` configuration parameter specifies how long the servers will wait before rolling back transactions.

On the failover server, if the number of seconds specified by `FAILOVER_TX_TIMEOUT` has expired, any open transactions that could not be synchronized with a surviving server are terminated and rolled back.

On the remaining secondary servers, if the number of seconds specified by `FAILOVER_TX_TIMEOUT` has expired, any open transactions on that server return an error.

Set `FAILOVER_TX_TIMEOUT` to 0 to immediately roll back all open transactions when failover occurs.

Limitations

If the primary server fails and a secondary server fails to take over the role of the primary server, then any open transactions are rolled back, and the client will be unable to perform any additional update activity. For example, suppose an update activity has been started on a secondary server and the primary server fails. Now suppose that failover processing does not complete and a new primary server is not established. After a predetermined amount of time, the client request (that is, the `sqlxexec` thread) times out, placing the `sqlxexec` thread in an indeterminate state.

In the preceding scenario, active transactions are rolled back, but the physical rollback cannot occur until the new primary server is established (because the primary server manages the logs). Under these circumstances, the session may be unaware of operations that have been performed on the secondary server. The session may be unaware of the rollback of a partially applied transaction because the rollback of the partial transaction cannot occur until a new primary server is established.

If your high-availability cluster contains an HDR secondary server, the `DRINTERVAL` configuration parameter must be set to -1 to enable transactions to complete after failover of the primary server. Setting `DRINTERVAL` to -1 on both the primary server and the HDR secondary server configures synchronous updates between the servers.

FASTPOLL Configuration Parameter

`onconfig.std` *value*
1

range of values

0 = Disables fast polling. 1 = Enables fast polling.

takes effect

When the database server is shut down and restarted

Use the `FASTPOLL` configuration parameter to enable or disable fast polling of your network. `FASTPOLL` is a platform-specific configuration parameter.

FILLFACTOR configuration parameter

Use the FILLFACTOR configuration parameter to specify the degree of index-page fullness. A low value provides room for growth in the index. A high value compacts the index.

If an index is full (100 percent), any new inserts result in splitting nodes. You can also set the FILLFACTOR as an option on the CREATE INDEX statement. The setting on the CREATE INDEX statement overrides the ONCONFIG file value.

You cannot use the FILLFACTOR configuration parameter with a forest of trees index.

onconfig.std *value*

90

units Percent

range of values

1 through 100

takes effect

When the index is built. Existing indexes are not changed. To use the new value, the indexes must be rebuilt.

When you reset the value dynamically in your onconfig file by running the **onmode -wf** command.

When you reset the value for a session by running the **onmode -wm** command.

refer to "Structure of B-Tree Index Pages" on page 4-16

Related reference:

"onmode -wf, -wm: Dynamically change certain configuration parameters" on page 15-26

FULL_DISK_INIT Configuration Parameter

Use the FULL_DISK_INIT configuration parameter to prevent an accidental disk reinitialization of an existing database server instance. This configuration parameter specifies whether or not the disk initialization command (**oninit -i**) can run on your Informix instance when a page zero exists at the root path location, which is at the first page of the first chunk location.

onconfig.std *value*

0

default value

0

takes effect

When the database server is shut down and restarted

range of values

0= The **oninit -i** command runs only if there is not a page zero at the root path location.

1 = The **oninit -i** command runs under all circumstances, but also resets the FULL_DISK_INIT configuration parameter to 0 after the disk initialization.

When the FULL_DISK_INIT configuration parameter is set to 1, any instance startup command (for example, **oninit** as well as **oninit -i**) resets the configuration parameter to 0.

If you start to run the **oninit -i** command when the FULL_DISK_INIT configuration parameter is set to 0 and the database server finds a page zero, the **oninit -i** command does not run and the server reports an error in the **online.log**.

Page zero is the Informix system page that contains general information about the server instance. This page is created when the server instance is initialized.

Related reference:

Chapter 13, "The oninit utility," on page 13-1

GSKIT_VERSION configuration parameter

Use the GSKIT_VERSION configuration parameter to specify the major version of IBM Global Security Kit (GSKit) that the database server uses for encryption and SSL communication.

If the database server is used with other IBM products on the same computer, and a different version of GSKit has been installed with one of the other IBM products, the database server can be configured to use the different version of GSKit. By default, the database server uses GSKit 8. You can set the GSKIT_VERSION parameter to use GSKit 7 or a later version of GSKit.

onconfig.std *value*
0

units Positive integer

range of values
7 to *The latest major release of GSKit*

takes effect
During database initialization

refer to

- The *IBM Informix Security Guide*

Related concepts:

 Secure sockets layer protocol (Security Guide)

 IBM Global Security Kit (Security Guide)

HA_ALIAS configuration parameter

Use the optional HA_ALIAS configuration parameter to specify the name by which the database server is known within a high-availability cluster.

onconfig.std *value*
None

takes effect
When the database server is shut down and restarted

When you reset the value dynamically in your onconfig file by running the **onmode -wf** command.

When you reset the value for a session by running the **onmode -wm** command.

Usage

The value specified by the HA_ALIAS configuration parameter must be one of the values specified in either the DBSERVERNAME or the DBSERVERALIASES configuration parameter, and the value must refer to a server with a connection type that is a TCP network protocol.

When a secondary server connects to a primary server, the secondary server sends the name of a network alias that can be used in case of failover. The setting of HA_ALIAS specifies the network alias that the secondary server sends.

The value specified by the HA_ALIAS configuration parameter is optional.

Related reference:

“onmode -wf, -wm: Dynamically change certain configuration parameters” on page 15-26

HETERO_COMMIT Configuration Parameter

onconfig.std *value*

0

range of values

1 = Enable heterogeneous commit. 0 = Disable heterogeneous commit.

takes effect

When the database server is shut down and restarted

refer to

- Heterogeneous commit protocol, in the chapter on multiphase commit protocols in the *IBM Informix Administrator's Guide*
- *IBM Informix Enterprise Gateway Manager User Manual*

The HETERO_COMMIT configuration parameter specifies whether or not the database server is prepared to participate with IBM Informix Gateway products in heterogeneous commit transactions. Setting HETERO_COMMIT to 1 allows a single transaction to update *one* non-Informix database (accessed with any of the Gateway products) and one or more Informix databases.

If HETERO_COMMIT is 0, a single transaction can update databases as follows:

- One or more Informix databases and no non-Informix databases
- One non-Informix database and no Informix databases

You can read data from any number of Informix and non-Informix databases, regardless of the setting of HETERO_COMMIT.

IFX_EXTEND_ROLE configuration parameter

Your database system administrator (DBSA), by default user **informix**, can use the IFX_EXTEND_ROLE parameter to control which users are authorized to register DataBlade modules or external user-defined routines (UDRs).

onconfig.std *value*

1

range of values

1 or On (default) = Enables the requirement for the EXTEND role so that administrators can grant privileges to a user to create or drop a UDR that includes the EXTERNAL clause.

0 or Off = Disables the requirement for the EXTEND role, so that any user who holds the USAGE ON LANGUAGE privilege for the appropriate external language (C or JAVA) can register or drop an external routine that was written in that language.

takes effect

After you edit your onconfig file and restart the database server.

When you reset the value dynamically in your onconfig file by running the **onmode -wf** command.

When you reset the value for a session by running the **onmode -wm** command.

refer to Information on security for external routines in the *IBM Informix Security Guide*

Related reference:

"onmode -wf, -wm: Dynamically change certain configuration parameters" on page 15-26

IFX_FOLDVIEW configuration parameter

Use the IFX_FOLDVIEW configuration parameter to enable or disable view folding. For certain situations where a view is involved in a query, view folding can significantly improve the performance of the query. In these cases, views are folded into a parent query instead of the query results being put into a temporary table.

onconfig.std value

0

range of values

0 or Off (default) = Disables view folding

1 or On = Enables view folding

takes effect

After you edit your onconfig file and restart the database server.

When you reset the value dynamically in your onconfig file by running the **onmode -wf** command.

When you reset the value for a session by running the **onmode -wm** command.

The following types of queries can take advantage of view folding:

- Views that contain a UNION ALL clause and the parent query has a regular join, an Informix join, an ANSI join, or an ORDER BY clause

A temporary table is created and view folding is not performed for the following types of queries that perform a UNION ALL operation involving a view:

- The view has one of the following clauses: AGGREGATE, GROUP BY, ORDER BY, UNION, DISTINCT, or OUTER JOIN (either Informix or ANSI type).
- The parent query has a UNION or UNION ALL clause.

Related concepts:

 Enable view folding to improve query performance (Performance Guide)

Related reference:

“onmode -wf, -wm: Dynamically change certain configuration parameters” on page 15-26

LIMITNUMSESSIONS configuration parameter

Use the LIMITNUMSESSIONS configuration parameter to define the maximum number of sessions that you want connected to Informix.

If you specify a maximum number, you can also specify whether you want Informix to print messages to the **online.log** file when the number of sessions approaches the maximum number.

If the LIMITNUMSESSIONS configuration parameter is enabled and sessions are restricted because of this limit, both regular user threads and DBSA user threads connecting to any database count against the limit. However, a DBSA user is allowed to connect to the server even after the limit has been reached.

Distributed queries against a server are also counted against the limit.

The LIMITNUMSESSIONS configuration parameter is not intended to be used as a means to adhere to license agreements.

onconfig.std *value*

Not set in the onconfig.std file

syntax LIMITNUMSESSIONS *maximum_number_of_sessions,print_warning*

separators

Comma

range of values

maximum_number_of_sessions = 0 to 2,097,152 (2*1024*1024). The default is 0.

print_warning = 0 (off) or 1 (on). The default for this optional value is 0.

takes effect

When the database server is shut down and restarted

When you reset the value dynamically in your onconfig file by running the **onmode -wf** command.

When you reset the value for a session by running the **onmode -wm** command.

If the print_warning is set to 1, a warning is triggered when the number of sessions is greater than or equal to 95 percent of the maximum_number_of_sessions value. If print_warning is set to zero, or if it is not set, no warning is issued. No new user sessions can be opened after the maximum_number_of_sessions limit is reached.

If the maximum_number_of_sessions value for the LIMITNUMSESSIONS configuration parameter is set to 0, or if it is not set, there is no limit to the number of sessions that can connect to the server.

The following example specifies that you want a maximum of 100 sessions to connect to the server and you want to print a warning message when the number of connected sessions approaches 100.

```
LIMITNUMSESSIONS 100,1
```

The settings in this example cause a warning to be printed when more than 94 sessions are concurrently connected. Only a member of the DBSA group can start a new session when 100 sessions are already connected.

Use **onmode -wf** or **onmode -wm**, or the equivalent SQL administration API ONMODE commands, to dynamically increase or temporarily disable the LIMITNUMSESSIONS setting. Use this configuration parameter to allow administrative utilities to run if the database server is reaching the maximum_number_of_sessions limit.

Related reference:

“onmode -wf, -wm: Dynamically change certain configuration parameters” on page 15-26

LISTEN_TIMEOUT configuration parameter

Use the LISTEN_TIMEOUT configuration parameter to specify the number of seconds in which the server waits for a connection.

onconfig.std *value*
60

Units Seconds

takes effect

When the database server is stopped and restarted

When you reset the value dynamically in your onconfig file by running the **onmode -wf** command.

When you reset the value for a session by running the **onmode -wm** command.

refer to IBM Informix Security Guide

You can set LISTEN_TIMEOUT to a lower number to guard against faulty connection requests that might indicate a Denial of Service attack. See also information about the MAX_INCOMPLETE_CONNECTIONS configuration parameter on page “MAX_INCOMPLETE_CONNECTIONS configuration parameter” on page 1-96.

Depending on the machine capability of holding the threads (in number), you can configure MAX_INCOMPLETE_CONNECTIONS to a higher value and depending on the network traffic, you can set LISTEN_TIMEOUT to a lower value to reduce the chance that an attack can reach the maximum limit.

Related reference:

“onmode -wf, -wm: Dynamically change certain configuration parameters” on page 15-26

LOCKS Configuration Parameter

The LOCKS configuration parameter specifies the initial size of the lock table.

The lock table holds an entry for each lock. If the number of locks allocated exceeds the value of the LOCKS configuration parameter, the database server increases the size of the lock table. The lock table can be increased a maximum of 99 times.

onconfig.std *value*

20000

units Number of locks in the internal lock table

range of values

2,000 through 8,000,000 for 32-bit database servers
2,000 through 500,000,000 for 64-bit database servers

takes effect

When the database server is shut down and restarted

utilities

onstat -k (see “**onstat -k** command: Print active lock information” on page 21-192.)

refer to

- The memory and locking chapters in your *IBM Informix Performance Guide*
- The shared memory chapter in the *IBM Informix Administrator's Guide*

The database server increases the size of the lock table by attempting to double the lock table on each increase. However, the amount added during each increase is limited to a maximum value. For 32-bit platforms, a maximum of 100,000 locks can be added during each increase. Therefore, the total maximum locks allowed for 32-bit platforms is 8,000,000 (maximum number of starting locks) + (99 (maximum number of dynamic lock table extensions) × 100,000 (maximum number of locks added per lock table extension)). For 64-bit platforms, a maximum of 1,000,000 locks can be added during each increase. Therefore, the total maximum locks allowed is 500,000,000 (maximum number of starting locks) + (99 (maximum number of dynamic lock table extensions) × 1,000,000 (maximum number of locks added per lock table extension)).

With the initial lock table stored in resident memory and each additional lock stored in virtual memory, locks can become a resource drain if you have a limited amount of shared memory. The amount of storage occupied by a single lock depends on the word size and operating system, and is subject to change. Currently, the amount of storage ranges from approximately 100 to 200 bytes. You can see the amount of storage required to support additional locks by restarting the server with a different value of the LOCKS configuration parameter (without making other changes), and observing the increase in memory used as shown by "onstat -g mem" for the resident pool.

Tip: When you drop a database, a lock is acquired and held on each table in the database until the database is dropped. For more information on the DROP DATABASE statement, see the *IBM Informix Guide to SQL: Syntax*.

LOGBUFF configuration parameter

Use the LOGBUFF configuration parameter to specify the size in kilobytes for the three logical-log buffers in shared memory.

onconfig.std *value*

LOGBUFF 64

units Kilobytes

values An integer in the range of 32 - $(32767 * \textit{pagesize} / 1024)$, where *pagesize* is the default system page size. The value must be evenly divisible by the default system page size. If the value is not evenly divisible by the page size, the database server rounds down the size to the nearest value that is evenly divisible by the page size.

takes effect

After you edit your onconfig file and restart the database server.

Usage

The three logical log buffers permit user threads to write to the active buffer while one of the other buffers is being flushed to disk. If flushing is not complete by the time the active buffer fills, the user thread begins writing to the third buffer.

If the RTO_SERVER_RESTART configuration parameter is enabled, set the value of the LOGBUFF configuration parameter to 256 kilobytes. If the value of the LOGBUFF configuration parameter is less than 256 kilobytes, a warning message displays when you restart the server.

Otherwise, set the value of the LOGBUFF configuration parameter to 32 kilobytes for standard workloads or 64 kilobytes for heavy workloads. The database server uses the LOGBUFF parameter to set the size of internal buffers that are used during recovery. If you set LOGBUFF too high, the database server can run out of memory and shut down during recovery.

If you log user data in smart large objects, increase the size of the log buffer to make the system more efficient. The database server logs only the portion of a smart-large-object page that changed.

You can view information about the logical log buffers by running the **onstat -l** command.

Related concepts:

 [Logical-log buffer \(Administrator's Guide\)](#)

Related reference:

 [Determine database server page size \(Administrator's Guide\)](#)

“**onstat -l** command: Print physical and logical log information” on page 21-193

LOGFILES configuration parameter

Use the LOGFILES configuration parameter to specify the number of logical-log files that the database server creates during disk initialization.

onconfig.std *value*

6

if not present

6

units Number of logical-log files

range of values

3 through 32,767 (integers only)

takes effect

During disk initialization and when you add a new log file. You add a new log with one of the following utilities.

utilities

onparams (see Chapter 17, “The onparams Utility,” on page 17-1)

refer to The following topics in the *IBM Informix Administrator's Guide*:

- Size of logical-log files, in the chapter on the logical log
- Adding or dropping a logical-log file, in the chapter on managing the logical log

To change the number of logical-log files, add or drop logical-log files.

If you use ISA or **onparams** to add or drop log files, the database server automatically updates LOGFILES.

LOG_INDEX_BUILDS Configuration Parameter

Use the LOG_INDEX_BUILDS configuration parameter to enable or disable index page logging.

onconfig.std *value*
None

if not present

0 (disabled)

values 0 = disable

1 = enable

takes effect

When the database server is stopped and restarted

When you reset the value dynamically in your onconfig file by running the **onmode -wf** command.

When you reset the value for a session by running the **onmode -wm** command.

Usage

If LOG_INDEX_BUILDS is enabled, logical log file space consumption will increase, depending on the size of the indexes. This might lead to logical log file backups being required more frequently. Messages are written to the `online.log` file when index page logging status changes.

Tip for RS secondary servers: Using **onmode -wm** enables or disables index page logging for the current session only, and does not affect the setting in the onconfig file. If the server is stopped and restarted, the setting in the onconfig file determines whether index page logging is enabled. Therefore, enabling index page logging using **onmode -wm** is not recommended when using RS secondary servers; instead, use **onmode -wf** to update the onconfig file, so that index page logging is enabled after restarting the server. Index page logging is a requirement when using RS secondary servers.

Related reference:

“onmode -wf, -wm: Dynamically change certain configuration parameters” on page 15-26

LOG_STAGING_DIR configuration parameter

Use the LOG_STAGING_DIR configuration parameter to specify the location of log files received from the primary server when configuring delayed application of log files on RS secondary servers.

onconfig.std value
None

if not present
not defined

range of values (first parameter)
Any valid, secure directory.

takes effect
After you edit your onconfig file and restart the database server.

When you reset the value dynamically in your onconfig file by running the **onmode -wf** command.

When you reset the value for a session by running the **onmode -wm** command.

refer to

- Information about data replication and RS secondary servers in the *IBM Informix Administrator's Guide*

Usage

The directory specified by the LOG_STAGING_DIR configuration parameter is used to store logs sent from the primary server when using the DELAY_APPLY configuration parameter to delay application of log files on an RS secondary server. Delaying the application of log files allows you to recover quickly from erroneous database modifications by restoring the data from the RS secondary server.

The directory specified by the LOG_STAGING_DIR configuration parameter must be secure. The directory must be owned by user **informix**, must belong to group **informix**, and must not have public read, write, or execute permission.

Related reference:

“onmode -wf, -wm: Dynamically change certain configuration parameters” on page 15-26

“DELAY_APPLY Configuration Parameter” on page 1-53

“STOP_APPLY configuration parameter” on page 1-154

LOGSIZE configuration parameter

Use the LOGSIZE configuration parameter to specify the size that is used when logical-log files are created. The LOGSIZE configuration parameter does not change the size of existing logical-log files. The total logical-log size is the value of the LOGSIZE configuration parameter multiplied by the value of the LOGFILES configuration parameter.

onconfig.std value

LOGSIZE 10000

units Kilobytes**values** An integer value.

Minimum value = 200

Maximum value = (ROOTSIZE - PHYSFILE - 512 - (63 * *pagesize*/1024))
/ LOGFILESThe *pagesize* value is the default system page size for the operating system.**takes effect**

After you edit your onconfig file and restart the database server.

When you reset the value dynamically in your onconfig file by running the **onmode -wf** command.When you reset the value for a session by running the **onmode -wm** command.**Usage**

When you change the value of the LOGSIZE configuration parameter, only new log files are affected. The size of existing log files does not change.

To verify the page size that the database server uses on your platform, run the **onstat -b** command.

If you declare logging for a smart-large-object column, you must ensure that the logical log is considerably larger than the amount of data logged during inserts or updates. The database server cannot back up open transactions. If many transactions are active, the total logging activity should not force open transactions to the log backup files. For example, if your log size is 1000 kilobytes and the high-watermark is 60 percent, do not use more than 600 kilobytes of the logical log for the smart-large-object updates. The database server starts rolling back the transaction when it reaches the high-watermark of 600 kilobytes.

Related concepts: Estimate the size and number of log files (Administrator's Guide)**Related reference:**

“onmode -wf, -wm: Dynamically change certain configuration parameters” on page 15-26

 Determine database server page size (Administrator's Guide)

“LTXHWM configuration parameter” on page 1-94

“onparams -p: Change physical-log parameters” on page 17-3

 Size of the logical-log file (Administrator's Guide)

LOW_MEMORY_MGR configuration parameter

Use the LOW_MEMORY_MGR configuration parameter to enable automatic low memory management, which you can use to change the default behavior of the server when it reaches its memory limit.

onconfig.std value

0

default value

0

range of values

1 = Enables automatic low memory management when the database server starts

0 = Disables automatic low memory management

takes effect

After you edit your onconfig file and restart the database server.

When you reset the value dynamically in your onconfig file by running the **onmode -wf** command.

When you reset the value for a session by running the **onmode -wm** command.

If you enable the LOW_MEMORY_MGR configuration parameter and configure the low memory manager to use a percentage of the SHMTOTAL value for the start and stop thresholds, use caution when changing the value of SHMTOTAL. Changing the value of the SHMTOTAL configuration parameter value can cause the configuration of automatic low memory management to become invalid, forcing the database server to use the default settings.

To enable automatic low memory management, specify:

```
LOW_MEMORY_MGR 1
```

Related reference:

“onmode -wf, -wm: Dynamically change certain configuration parameters” on page 15-26

“SHMTOTAL configuration parameter” on page 1-137

“scheduler lmm enable argument: Specify automatic low memory management settings (SQL administration API)” on page 22-102

“scheduler lmm disable argument: Stop automatic low memory management (SQL administration API)” on page 22-105

LOW_MEMORY_RESERVE configuration parameter

Use the LOW_MEMORY_RESERVE configuration parameter to reserve a specific amount of memory for use when critical activities are needed and the server has limited free memory.

If you enable the new LOW_MEMORY_RESERVE configuration parameter by setting it to a specified value in kilobytes, critical activities, such as rollback activities, can complete even when you receive out-of-memory errors.

onconfig.std *value*

0

default value

0

default units

kilobytes

range of values

0 or 128 to 2147483648, although the maximum value cannot be higher than 20 percent of the value of the SHMVIRTSIZE configuration parameter

takes effect

After you edit your `onconfig` file and restart the database server.

When you reset the value dynamically in your `onconfig` file by running the **onmode -wf** command.

When you reset the value for a session by running the **onmode -wm** command.

No matter how the `LOW_MEMORY_RESERVE` configuration parameter is set, the maximum size of reserved memory is 20 percent of the value of the `SHMVIRTSIZE` configuration parameter.

For example, to reserve 512 kilobytes of memory, specify:

```
LOW_MEMORY_RESERVE 512
```

You can use the **onstat -g seg** command to view low-memory reserve information. The output includes lines that show the size of reserved memory, the number of times that the server has used the reserved memory, and the maximum memory needed.

Related reference:

“`onmode -wf, -wm`: Dynamically change certain configuration parameters” on page 15-26

“**onstat -g seg** command: Print shared memory segment statistics” on page 21-161

“`SHMVIRTSIZE` configuration parameter” on page 1-139

LTXEHWM configuration parameter

Use the `LTXEHWM` configuration parameter to specify the *long-transaction, exclusive-access, high-watermark*. When the logical-log space reaches the `LTXEHWM` threshold, the long transaction currently being rolled back is given *exclusive* access to the logical log.

onconfig.std *value*
80

if not present

90 (if `DYNAMIC_LOGS` is set to 1 or 2) 60 (if `DYNAMIC_LOGS` is set to 0)

units Percent

range of values

`LTXHWM` through 100

takes effect

After you edit your `onconfig` file and restart the database server.

When you reset the value dynamically in your `onconfig` file by running the **onmode -wf** command.

When you reset the value for a session by running the **onmode -wm** command.

refer to

- Setting high-watermarks for rolling back long transactions, in the chapter on managing logical logs in the *IBM Informix Administrator's Guide*

Usage

A *transaction* is *long* if it is not committed or rolled back when it reaches the long-transaction high-watermark.

If your system runs out of log space before the rollback completes, lower the LTXEHWM value.

If you do not want too many logical logs to be added, LTXEHWM should be set to a smaller value (around 60). If dynamic logging is turned off (DYNAMIC_LOGS = 0), LTXEHWM should be set lower (around 50) to avoid running out of logical space.

Tip: To allow users to continue to access the logical logs, even during a long transaction rollback, set *LTXEHWM* to 100. Set *DYNAMIC_LOGS* to 1 or 2 so that the database server can add a sufficient number of log files to prevent long transactions from hanging and to allow long transactions to roll back.

Related reference:

“onmode -wf, -wm: Dynamically change certain configuration parameters” on page 15-26

“DYNAMIC_LOGS configuration parameter” on page 1-69

“LTXHWM configuration parameter”

 Set high-watermarks for rolling back long transactions (Administrator's Guide)

LTXHWM configuration parameter

Use the LTXHWM configuration parameter to specify the long-transaction high-watermark. The *long-transaction high-watermark* is the percentage of available log space that, when filled, triggers the database server to check for a long transaction.

onconfig.std *value*
70

if not present

80 (if DYNAMIC_LOGS is set to 1 or 2) 50 (if DYNAMIC_LOGS is set to 0)

units Percent

range of values

1 through 100

takes effect

After you edit your onconfig file and restart the database server.

When you reset the value dynamically in your onconfig file by running the **onmode -wf** command.

When you reset the value for a session by running the **onmode -wm** command.

Usage

When the logical-log space reaches the LTXHWM threshold, the database server starts rolling back the transaction. If you decrease the LTXHWM value, increase the size or number of log files to make rollbacks less likely.

If DYNAMIC_LOGS is set to 1 or 2, the database server can add a sufficient number of log files to complete the transactions or to prevent rollbacks from hanging when you have long transactions.

If you do not want too many logical logs to be added, LTXHWM should be set to a smaller value (around 60). If dynamic logging is turned off (DYNAMIC_LOGS = 0), LTXHWM should be set lower (around 50) to avoid running out of logical space.

Warning: If you set both LTXHWM and LTXEHWM to 100, long transactions are never aborted. Although you can use this configuration to your advantage, you should set LTXHWM to below 100 for normal database server operations.

If you set LTXHWM to 100, the database server issues a warning message:

LTXHWM is set to 100%. This long transaction high water mark will never be reached. Transactions will not be aborted automatically by the server, regardless of their length.

If the transaction hangs, follow the instructions for recovering from a long transaction hang, in the chapter on managing logical-log files in the *IBM Informix Administrator's Guide*.

Related reference:

“onmode -wf, -wm: Dynamically change certain configuration parameters” on page 15-26

“DYNAMIC_LOGS configuration parameter” on page 1-69

“LTXEHWM configuration parameter” on page 1-93

 Set high-watermarks for rolling back long transactions (Administrator's Guide)

“LOGSIZE configuration parameter” on page 1-90

MAX_FILL_DATA_PAGES Configuration Parameter

onconfig.std *value*

0

units Integer

range of values

0 or 1

takes effect

When the database server is stopped and restarted

refer to Reducing disk space through additional rows per page in tables with variable-length rows in the *IBM Informix Performance Guide*

Set the MAX_FILL_DATA_PAGES value to 1 to allow more rows to be inserted per page in tables that have variable-length rows. This setting can reduce disk space, make more efficient use of the buffer pool, and reduce table scan times.

If MAX_FILL_DATA_PAGES is enabled, the server will add a new row to a recently modified page with existing rows if adding the row leaves at least 10 percent of the page free for future expansion of all the rows in the page. If MAX_FILL_DATA_PAGES is not set, the server will add the row only if there is sufficient room on the page to allow the new row to grow to its maximum length.

A possible disadvantage of enabling MAX_FILL_DATA_PAGES and allowing more variable-length rows per page is that the server might store rows in a different physical order. Also, as the page fills, updates made to the variable-length columns in a row could cause the row to expand so it no longer completely fits on the page. This causes the server to split the row onto two pages, increasing the access time for the row.

To take advantage of this setting, existing tables with variable-length rows must be reloaded or existing pages must be modified, followed by further inserts.

MAX_INCOMPLETE_CONNECTIONS configuration parameter

Use the MAX_INCOMPLETE_CONNECTIONS configuration parameter to specify the maximum number of incomplete connections in a session.

onconfig.std *value*

1024

units Number of incomplete connections

takes effect

After you edit your onconfig file and restart the database server.

When you reset the value dynamically in your onconfig file by running the **onmode -wf** command.

When you reset the value for a session by running the **onmode -wm** command.

Usage

After the number specified in the MAX_INCOMPLETE_CONNECTIONS configuration parameter is reached, an error message is written in the online message log stating that the server might be under a Denial of Service attack. See also information about the LISTEN_TIMEOUT configuration parameter, which specifies the number of seconds the server waits for a connection. “LISTEN_TIMEOUT configuration parameter” on page 1-86.

Depending on the machine capability of holding the threads (in number), you can configure MAX_INCOMPLETE_CONNECTIONS to a higher value. Depending on the network traffic, you can also set the LISTEN_TIMEOUT configuration parameter, which specifies the number of seconds the server waits for a connection, to a lower value to reduce the chance that an attack can reach the maximum limit. For more information, see “LISTEN_TIMEOUT configuration parameter” on page 1-86.

Related reference:

“onmode -wf, -wm: Dynamically change certain configuration parameters” on page 15-26

MAX_PDQPRIORITY configuration parameter

Use the MAX_PDQPRIORITY configuration parameter to limit the PDQ resources that the database server can allocate to any one DSS query.

onconfig.std *value*

100

if not present

100

range of values
0 through 100

takes effect

On all user sessions after you edit your onconfig file and restart the database server.

When you reset the value dynamically in your onconfig file by running the **onmode -wf** command.

When you reset the value for a session by running the **onmode -wm** command.

utilities

onmode -D onstat -g mgm (See “**onstat -g mgm** command: Print MGM resource information” on page 21-116.)

refer to

- The chapter on using PDQ, in the *IBM Informix Performance Guide*
- “onmode -D, -M, -Q, -S: Change decision-support parameters” on page 15-12

MAX_PDQPRIORITY is a factor that is used to scale the value of PDQ priority set by users. For example, suppose that the database administrator sets MAX_PDQPRIORITY to 80. If a user sets the PDQPRIORITY environment variable to 50 and then issues a query, the database server silently processes the query with a PDQ priority of 40.

Usage

You can use the **onmode** utility to change the value of MAX_PDQPRIORITY while the database server is online.

In Informix, PDQ resources include memory, CPU, disk I/O, and scan threads. MAX_PDQPRIORITY lets the database administrator run decision support concurrently with OLTP, without a deterioration of OLTP performance. However, if MAX_PDQPRIORITY is too low, the performance of decision- support queries can degrade.

You can set MAX_PDQPRIORITY to one of the following values.

Value Database Server Action

- | | |
|------------|---|
| 0 | Turns off PDQ. DSS queries use no parallelism. |
| 1 | Fetches data from fragmented tables in parallel (parallel scans) but uses no other form of parallelism. |
| 100 | Uses all available resources for processing queries in parallel. |

number

An integer between 0 and 100. Sets the percentage of the user-requested PDQ resources actually allocated to the query.

Related reference:

“onmode -wf, -wm: Dynamically change certain configuration parameters” on page 15-26

MIRROR Configuration Parameter

onconfig.std *value*

0

range of values

0 = disable mirroring 1 = enable mirroring

takes effect

When the database server is shut down and restarted

utilities

onstat -d *flags* field (see “**onstat -d** command: Print chunk information” on page 21-34.)

refer to The following topics in the *IBM Informix Administrator's Guide*:

- Mirroring critical data in the chapter on where is data stored
- Enabling mirroring in the chapter on using mirroring

The MIRROR parameter indicates whether mirroring is enabled for the database server. It is recommended that you mirror the root dbspaces and the critical data as part of initialization. Otherwise, leave mirroring disabled. If you later decide to add mirroring, you can edit your configuration file to change the parameter value.

You do not have to set the MIRROR configuration parameter to the same value on both database servers in the high-availability data-replication pair. You can enable or disable mirroring on either the primary or the secondary database server independently. Do not set the MIRROR configuration parameter to 1 unless you are using mirroring.

MIRROROFFSET Configuration Parameter

onconfig.std *value*

0

units Kilobytes

range of values

Any value greater than or equal to 0

takes effect

When the database server is shut down and restarted

refer to Mirroring the root dbspace during initialization, in the chapter on using mirroring in the *IBM Informix Administrator's Guide*

In Informix, MIRROROFFSET specifies the offset into the disk partition or into the device to reach the chunk that serves as the mirror for the initial chunk of the root dbspace.

MIRRORPATH configuration parameter

Use the MIRRORPATH configuration parameter to specify the full path name of the mirrored chunk for the initial chunk of the root dbspace.

onconfig.std *value*

On UNIX: \$INFORMIXDIR/tmp/demo_on.root_mirror
On Windows: None

range of values

65 or fewer characters

takes effect

When the database server is shut down and restarted

refer to The following material in the *IBM Informix Administrator's Guide*:

- Mirroring the root dbspace during initialization, in the chapter on using mirroring
- Using links, in the chapter on managing disk space

The MIRRORPATH should be a link to the chunk path name of the actual mirrored chunk for the same reasons that ROOTPATH is specified as a link. Similarly, select a short path name for the mirrored chunk.

Setting Permissions (UNIX)

You must set the permissions of the file that MIRRORPATH specifies to 660. The owner and group must both be **informix**.

If you use raw disk space for your mirror chunk on a UNIX platform, it is recommended that you define MIRRORPATH as a path name that is a link to the initial chunk of the mirror dbspace, instead of entering the actual device name for the initial chunk.

MSG_DATE configuration parameter

Use the MSG_DATE configuration parameter to enable the insertion of a date in MM/DD/YY format at the beginning of each message printed to the online log.

onconfig.std *value*

Not in the onconfig.std template file

range of values

0 = OFF (the default)
1 = ON

takes effect

After you edit your onconfig file and restart the database server.

When you reset the value dynamically in your onconfig file by running the **onmode -wf** command.

When you reset the value for a session by running the **onmode -wm** command.

In the following example MSG_DATE is set to 1 (ON).

```
04/10/11 10:26:06 Value of MSG_DATE has been changed to 1.  
04/10/11 10:27:35 Value of MSG_DATE has been changed to 1.
```

Related reference:

“onmode -wf, -wm: Dynamically change certain configuration parameters” on page 15-26

MSGPATH configuration parameter

Use the MSGPATH configuration parameter to specify the full pathname of the message-log file. The database server writes status messages and diagnostic messages to this file during operation.

onconfig.std *value*

On UNIX: `$INFORMIXDIR/tmp/online.log` On Windows: `online.log`

range of values

Pathname

takes effect

After you edit your onconfig file and restart the database server.

When you reset the value dynamically in your onconfig file by running the **onmode -wf** command.

When you reset the value for a session by running the **onmode -wm** command.

utilities

onstat -m to view the message log (For more information, see “**onstat -l** command: Print physical and logical log information” on page 21-193.)

refer to Message log, in the chapter on overview of database server administration in the *IBM Informix Administrator's Guide*

Usage

If the file that MSGPATH specifies does not exist, the database server creates the file in the specified directory. If the directory that MSGPATH specifies does not exist, the database server sends the messages to the system console.

If the file that MSGPATH specifies does exist, the database server opens it and appends messages to it as they occur.

Related reference:

“onmode -wf, -wm: Dynamically change certain configuration parameters” on page 15-26

MULTIPROCESSOR Configuration Parameter

onconfig.std *value*

0

if not present

Platform dependent

range of values

0 = No multiprocessor 1 = Multiprocessor available

takes effect

When the database server is shut down and restarted

refer to CPU virtual processors, in the chapter on virtual processors in the *IBM Informix Administrator's Guide*

If MULTIPROCESSOR is set to 0, the parameters that set processor affinity are ignored. MULTIPROCESSOR specifies whether the database server performs locking in a manner that is suitable for a single-processor computer or a multiprocessor computer.

NET_IO_TIMEOUT_ALARM configuration parameter

Use the NET_IO_TIMEOUT_ALARM configuration parameter to control whether to be notified if network write operations have been blocked for 30 minutes or more.

onconfig.std

Not in onconfig.std

default value

0

range of values

One of the following values or a sum of one or more of the following values:

- 0 = Disabled
- 1 = Enabled for Enterprise Replication operations
- 2 = Enabled for distributed queries
- 4 = Enabled for HDR operations
- 8 = Enabled for SMX operations
- 16 = Enabled for other component operations

takes effect

After you edit your onconfig file and restart the database server.

When you reset the value dynamically in your onconfig file by running the **onmode -wf** command.

When you reset the value for a session by running the **onmode -wm** command.

Blocked network write operations usually indicate an operating system problem. Use the NET_IO_TIMEOUT_ALARM configuration parameter to enable event alarm 82 for specific types of network traffic.

Related reference:

“onmode -wf, -wm: Dynamically change certain configuration parameters” on page 15-26

NETTYPE Configuration Parameter

Use the NETTYPE parameter to tune the network protocols that are defined in the sqlhosts file or registry.

onconfig.std values

On UNIX: ipcshm,1,50,CPU

On Windows: Not set.

default value

connection_type,1,50,vp_class

The default connection type depends on the operating system:

- On UNIX: The value of the **protocol** field from the sqlhosts file.

- On Windows: onsoctcp

The default virtual processor class depends on the **dbservername** entry in the sqlhosts file:

- CPU, if the **dbservername** sqlhosts entry is defined by the DBSERVERNAME configuration parameter.
- NET, if the **dbservername** sqlhosts entry is defined by the DBSERVERALIASES configuration parameter.

separators

Separate fields with commas. Do not include blank spaces. If you can omit values for fields, but you must include a comma for each field. However, you can omit trailing commas.

values See the Usage section.

takes effect

After you edit your onconfig file and restart the database server.

Usage

The NETTYPE parameter provides tuning options for the protocol and interface combinations that are associated with **dbservername** entries in the sqlhosts file or registry. Each **dbservername** entry in the sqlhosts file or registry is defined on either the DBSERVERNAME configuration parameter or the DBSERVERALIASES configuration parameter in the onconfig file.

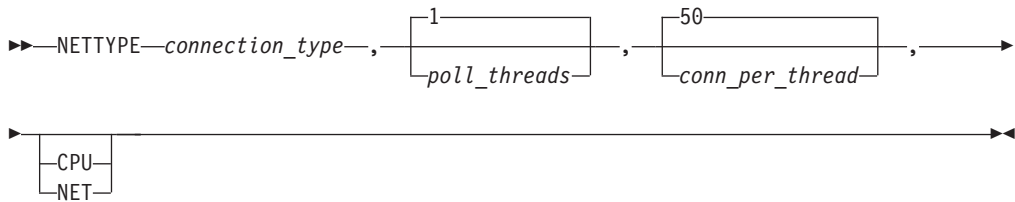

Table 1-60. Options for the NETTYPE configuration parameter value

Field	Values
connection_type	A valid protocol and interface combination, with or without the database server prefix of on , ol , or dr .

Table 1-60. Options for the NETTYPE configuration parameter value (continued)

Field	Values
<i>poll_threads</i>	<p>The number of poll threads assigned to the connection type. Default is 1. The range of values depends on the operating system and the virtual processor class:</p> <ul style="list-style-type: none"> • On UNIX: If the virtual processor class is NET, an integer greater than or equal to 1. Each poll thread requires a separate virtual processor, so you indirectly specify the number of networking virtual processors when you specify the number of poll threads for an interface/protocol combination and specify that they are to be run by the NET class. • On UNIX: If the virtual processor class is CPU, an integer from 1 through the number of CPU VPs. • On Windows: An integer greater than or equal to 1. <p>If your database server has a large number of connections, you might be able to improve performance by increasing the number of poll threads. In general, each poll thread can handle approximately 200 to 250 connections.</p> <p>On Windows, if you specify the soctcp protocol, only one poll thread is created, and instead, a socket I/O thread (soctpio) is created in its own SOC VP for each poll thread specified by the NETTYPE parameter. Socket IO threads handle receive operations for all connections using I/O completion ports to receive completion notifications. These threads perform the bulk of the work of servicing network connections on Windows platforms.</p>
<i>conn_per_thread</i>	<p>An integer from 1 - 32767 that sets the maximum number of connections for each poll thread. Default is 50.</p> <p>For shared memory connections, the value of <i>conn_per_thread</i> is the maximum number of connections per thread. In general, you should specify double the number of expected connections.</p> <p>For network connections, the value of <i>conn_per_thread</i> can be exceeded. Poll threads dynamically reallocate resources to support more connections, as needed. Avoid setting the value for the number of concurrent connections much higher than you expect. Otherwise, you might waste system resources.</p> <p>If only a few connections will be using a protocol concurrently, you might save memory by explicitly setting the estimated number of connections.</p>
CPU	<p>Specifies a CPU virtual processor. Use CPU virtual processors for shared memory connections, which should run in every CPU virtual processor.</p>
NET	<p>Specifies a NET virtual processor. Use NET virtual processors for network connections. TCP connections should only be in NET virtual processors, and you should only specify the minimum number of TCP connections to maintain responsiveness.</p> <p>If must specify a NET virtual processor is you have VPCLASS configuration parameter entries for the <i>tli</i>, <i>shm</i>, <i>str</i>, or <i>soc</i> virtual processors.</p>

You can specify a NETTYPE parameter for each protocol that you want the database server to use. The following example illustrates NETTYPE parameters for

two types of connections to the database server: a shared memory connection for local clients, and a network connection that uses sockets:

```
NETTYPE ipcshm,3,,CPU  
NETTYPE soctcp,8,300,NET
```

The NETTYPE parameter for the shared-memory connection (**ipcshm**) specifies three poll threads to run in CPU virtual processors. The number of connections is not specified, so it is set to 50. For **ipcshm**, the number of poll threads correspond to the number of memory segments.

The NETTYPE parameter for the sockets connection (**soctcp**) specifies that only 20 simultaneous connections are expected per thread for this protocol and that one poll thread (because the number of poll threads is not specified) will run in a NET virtual processor.

IBM Informix MaxConnect

If you are using IBM Informix MaxConnect, see the *IBM Informix MaxConnect User's Guide* for how to specify the fields in the NETTYPE parameter. The **ontliimc** and **onsocimc** protocols use TCP/IP to communicate with Informix MaxConnect. You can use these protocols to either connect Informix MaxConnect or the application clients to the database server.

Related concepts:

 [Specifying the number of connections and poll threads \(Performance Guide\)](#)

 [CPU virtual processors \(Administrator's Guide\)](#)

Related reference:

["DBSERVERNAME configuration parameter" on page 1-46](#)

["DBSERVERALIASES configuration parameter" on page 1-44](#)

["NUMFDSERVERS configuration parameter" on page 1-106](#)

["VPCLASS configuration parameter" on page 1-167](#)

["onstat -g nsc command: Print current shared memory connection information" on page 21-121](#)

["onstat -g nsd command: Print poll threads shared-memory data" on page 21-124](#)

["onstat -g nss command: Print shared memory network connections status" on page 21-124](#)

 [Run poll threads on CPU or network virtual processors \(Administrator's Guide\)](#)

 [Specify the number of networking virtual processors \(Administrator's Guide\)](#)

 [Connection information set in the NETTYPE configuration parameter \(Administrator's Guide\)](#)

 [sqlhosts Connectivity information \(Administrator's Guide\)](#)

 [Network virtual processors \(Administrator's Guide\)](#)

NS_CACHE configuration parameter

Use the NS_CACHE configuration parameter to define the maximum retention time for entries in the Informix name service caches: the host name/IP address cache, the service cache, the user cache, and the group cache.

onconfig.std value

NS_CACHE host=900,service=900,user=900,group=900

values Each of the fields takes an integer value equal to or greater than 0.

host = Sets the number of seconds to cache information in the host name or IP address cache.

service = Sets the number of seconds to cache information in the service cache.

user = Sets the number of seconds to cache information in the user cache.

group = Sets the number of seconds to cache information in the group cache.

0 = Caching is disabled. The server always gets information from the operating system. You can set an individual cache to 0 or set all name service caches to 0: NS_CACHE 0.

units Seconds

separators

Separate values with a comma. Do not include blank spaces.

takes effect

After you edit your onconfig file and restart the database server.

When you reset the value dynamically in your onconfig file by running the **onmode -wf** command.

When you reset the value for a session by running the **onmode -wm** command.

Usage

For looking up and resolving host names (or IP addresses), service names, users (and passwords) or groups, the database server queries the operating system (OS) using appropriate system calls. You can avoid many of these OS lookups by using the Informix name service caching mechanism, which can keep and reuse each retrieved piece of information for a configurable amount of time. You should set the NS_CACHE configuration parameter if your operating system does not provide its own caching.

The server can get information from the cache faster than it does when querying the operating system. However, if you disable one or more of these caches by setting the retention time to 0, the database server queries the operating system for the host, service, user, or group information.

Changes that are made to name services at the operating system level are not immediately reflected in the Informix name server caches: for example, the change of an IP address, a user added to or removed from a group, or a new password. However, you can use the **onmode -wf** or **onmode -wm** command to change NS_CACHE information immediately. When you change the value for a particular cache with the **onmode -wf** or **onmode -wm** command, the server immediately expires all existing entries in that cache.

Related concepts:

 Name service maximum retention time set in the NS_CACHE configuration parameter (Administrator's Guide)

 Improve connection performance and scalability (Performance Guide)

Related reference:

“onmode -wf, -wm: Dynamically change certain configuration parameters” on page 15-26

NUMFDSERVERS configuration parameter

For network connections on UNIX, use the NUMFDSERVERS configuration parameter to specify the maximum number of poll threads to handle network connections migrating between Informix virtual processors (VPs).

Specifying NUMFDSERVERS information is useful if Informix has a high rate of new connect and disconnect requests or if you find a high amount of contention between network shared file (NSF) locks. You can use the **onstat -g ath** command to display information about all threads. This information includes a status, such as `mutex wait nsf.lock`, which indicates that you have a significant amount of NSF lock contention.

onconfig.std *value*

4

default value

4 (Only the first 4 poll threads of each **nettype** are involved in managing the connection migrations.)

range of values

1 to 50

The actual number depends on the number of poll threads, which you specify in the NETTYPE configuration parameter.

takes effect

When the database server is shut down and restarted

The specified value of NUMFDSERVERS has no effect on shared-memory (SHM) connections.

If you use the NUMFDSERVERS configuration parameter, also review, and if necessary, change the number of poll threads in the NETTYPE configuration parameter. For example, if you have multiple CPU VPs and poll threads and this results in NSF locking, you can increase NUMFDSERVERS and poll threads to reduce NSF lock contention.

Related concepts:

 Improve connection performance and scalability (Performance Guide)

Related reference:

“NETTYPE Configuration Parameter” on page 1-101

“DBSERVERNAME configuration parameter” on page 1-46

“DBSERVERALIASES configuration parameter” on page 1-44

“**onstat -g ath** command: Print information about all threads” on page 21-54

OFF_RECVRY_THREADS configuration parameter

Use the OFF_RECVRY_THREADS configuration parameter to specify the number of recovery threads used in logical recovery when the database server is offline (during a cold restore). This number of threads is also used to roll forward logical-log records in fast recovery.

onconfig.std *value*

10

units Number of recovery threads that run in parallel

range of values

Positive integers

takes effect

When the database server is shut down and restarted

refer to

- *IBM Informix Backup and Restore Guide*
- *IBM Informix Performance Guide*

Before you perform a cold restore, you can set the value of this parameter to approximately the number of tables that have a large number of transactions against them in the logical log. For single-processor computers or nodes, more than 30 to 40 threads is probably too many, because the overhead of thread management offsets the increase in parallel processing.

ON_RECVRY_THREADS Configuration Parameter

onconfig.std *value*

1

units Number of recovery threads that run in parallel

range of values

Positive integers

takes effect

When the database server is shut down and restarted

refer to

- *IBM Informix Backup and Restore Guide*
- *IBM Informix Performance Guide*

ON_RECVRY_THREADS is the maximum number of recovery threads that the database server uses for logical recovery when the database server is online (during a warm restore).

You can tune `ON_RECOVERY_THREADS` to the number of tables that are likely to be recovered, because the logical-log records that are processed during recovery are assigned threads by table number. The maximum degree of parallel processing occurs when the number of recovery threads matches the number of tables being recovered.

To improve the performance of warm restores, increase the number of fast-recovery threads with the `ON_RECOVERY_THREADS` parameter.

ONDBSPACEDOWN configuration parameter

Use the `ONDBSPACEDOWN` configuration parameter to define the action that the database server takes when any disabling event occurs on a primary chunk within a noncritical dbspace.

onconfig.std *value*
2

range of values

0 = The database server marks the dbspace as offline and continues.

1 = The database server aborts.

2 = The database server writes the status of the chunk to the logs and waits for user input. If you set this option, but you want the database server to mark a disabled dbspace as down and continue processing, use **onmode -O** to override this `ONDBSPACEDOWN` setting. See “`onmode -O`: Override `ONDBSPACEDOWN` WAIT mode” on page 15-20.

takes effect

After you edit your `onconfig` file and restart the database server.

When you reset the value dynamically in your `onconfig` file by running the **onmode -wf** command.

When you reset the value for a session by running the **onmode -wm** command.

refer to Monitoring the database server for disabling I/O errors, in the chapter on consistency checking in the *IBM Informix Administrator's Guide*

Related reference:

“`onmode -wf, -wm`: Dynamically change certain configuration parameters” on page 15-26

Database Server Behavior When `ONDBSPACEDOWN` Does Not Apply

The database server will not come online if a chunk within any **critical** dbspace (for example, `rootdbs` or `logsdbs`) is missing.

The value of `ONDBSPACEDOWN` has no effect on temporary dspsaces. For temporary dspsaces, the database server continues processing regardless of the `ONDBSPACEDOWN` setting. If a temporary dspsace requires fixing, you should drop and recreate it.

For a non-primary chunk within a noncritical dspsace, the behavior of the database server depends on the transaction status of the chunk when the disabling event occurs:

- **No transaction:** If no transactions are detected against that chunk, the chunk is individually marked as down. In this case, subsequent attempts to write to that chunk fail, rolling back the associated transaction. You can safely put the chunk back and then use the **onspaces -s** utility to mark the chunk as back online.
- **Transaction detected:** If there are transactions to roll forward or back, then the database server aborts with an appropriate fast recovery error. In this case, you should put the chunk back and restart the database server.

ONLIDX_MAXMEM configuration parameter

Use the ONLIDX_MAXMEM configuration parameter to limit the amount of memory that is allocated to a single *preimage* pool and a single *updater* log pool.

onconfig.std *value*
5120

units Kilobytes

range of values
16 through 4294967295

takes effect

After you edit your onconfig file and restart the database server.

When you reset the value dynamically in your onconfig file by running the **onmode -wf** command.

When you reset the value for a session by running the **onmode -wm** command.

Usage

The preimage and updater log pools, **pimage_partnum** and **uolog_partnum**, are shared memory pools that are created when a CREATE INDEX ONLINE statement is executed. The pools are freed when the execution of the statement is completed.

If you specify a value for this parameter and then create a table, add rows to the table, and start to execute a CREATE INDEX ONLINE statement on a column, you can also perform other operations on the column, such as running UPDATE STATISTICS HIGH, without having memory problems.

Related reference:

“onmode -wf, -wm: Dynamically change certain configuration parameters” on page 15-26

OPCACHEMAX Configuration Parameter (UNIX)

onconfig.std *value*
0

if not present
128

units Kilobytes

range of values
0 through (4 * 1024 * 1024)

takes effect

When the Optical Subsystem needs more memory

utilities

onstat -O (For more information, see “**onstat -o** command: Output shared memory contents to a file” on page 21-198.)

refer to

- *IBM Informix Optical Subsystem Guide*
- **INFORMIXOPCACHE** environment variable, in the *IBM Informix Guide to SQL: Reference*

OPCACHEMAX specifies the size of the memory cache for the Optical Subsystem. The database server stores pieces of TEXT or BYTE data in the memory cache before it delivers them to the subsystem. Use this parameter only if you use the Optical Subsystem.

The **INFORMIXOPCACHE** environment variable lets the client restrict the size of the optical cache that it uses.

Related reference:

 [INFORMIXOPCACHE environment variable \(SQL Reference\)](#)

OPTCOMPIND configuration parameter

Use the OPTCOMPIND to specify information that helps the optimizer choose an appropriate query plan for your application.

Tip: You can think of the name of the variable as arising from “OPTimizer COMPare (the cost of using) INDexes (with other methods).”

onconfig.std *value*
2

range of values

0 = When appropriate indexes exist for each ordered pair of tables, the optimizer chooses index scans (nested-loop joins), without consideration of the cost, over table scans (hash joins). This value ensures compatibility with previous versions of the database server.

1 = The optimizer uses costs to determine an execution path if the isolation level is not Repeatable Read. Otherwise, the optimizer chooses index scans (it behaves as it does for the value 0). This setting is recommended for optimal performance.

2 = The optimizer uses cost to determine an execution path for any isolation level. Index scans are not given preference over table scans; the optimizer bases its decision purely on cost. This value is the default if the variable is not set.

takes effect

After you edit your onconfig file and restart the database server.

When you reset the value dynamically in your onconfig file by running the **onmode -wf** command.

When you reset the value for a session by running the **onmode -wm** command.

refer to

- Your *IBM Informix Performance Guide*
- **OPTCOMPIND** environment variable, in the *IBM Informix Guide to SQL: Reference*

- SET ENVIRONMENT OPTCOMPIND statement to dynamically change the value of the OPTCOMPIND configuration parameter for a session, in the *IBM Informix Guide to SQL: Syntax*

Usage

Because of the nature of *hash joins*, an application with isolation mode set to Repeatable Read might *temporarily* lock all records in tables that are involved in the join (even those records that fail to qualify the join) for each ordered set of tables. This situation leads to higher contention among connections. Conversely, nested-loop joins lock fewer records but provide inferior performance when the database server retrieves a large number of rows. Thus, both join methods offer advantages and disadvantages. A client application can also influence the optimizer in its choice of a join method.

Related concepts:

[➤](#) OPTCOMPIND Environment Option (SQL Syntax)

Related reference:

“onmode -wf, -wm: Dynamically change certain configuration parameters” on page 15-26

[➤](#) OPTCOMPIND environment variable (SQL Reference)

OPT_GOAL Configuration Parameter

onconfig.std *value*
-1

range of values
0 or -1

takes effect
When the database server is shut down and restarted

refer to The following manuals:

- ALL_ROWS and FIRST_ROWS directives and on the SET OPTIMIZATION statement, in the *IBM Informix Guide to SQL: Syntax*
- **OPT_GOAL** environment variable, in the *IBM Informix Guide to SQL: Reference*
- Performance issues associated with setting an optimization goal, in the *IBM Informix Performance Guide*

The OPT_GOAL parameter enables you to specify one of the following optimization goals for queries:

- Optimize for FIRST ROWS
- Optimize for ALL ROWS

A value of 0 sets the optimization goal to FIRST_ROWS. A value of -1 sets the optimization goal to ALL_ROWS, which is the default.

When you set the optimization goal to optimize for FIRST ROWS, you specify that you want the database server to optimize queries for perceived response time. In other words, users of interactive applications perceive response time as the time that it takes to display data on the screen. Setting the optimization goal to FIRST ROWS configures the database server to return the first rows of data that satisfy the query.

When you set the optimization goal to optimize for ALL ROWS, you specify that you want the database server to optimize for the total execution time of the query. Making ALL ROWS the optimization goal instructs the database server to process the total query as quickly as possible, regardless of how long it takes to return the first rows to the application.

You can specify the optimization goal in one of four ways:

- By query (SELECT statement)
Use the ALL_ROWS and FIRST_ROWS directives.
- By session
Use the SET OPTIMIZATION statement.
- By environment
Set the **OPT_GOAL** environment variable.
- By database server
Set the OPT_GOAL configuration parameter.

The list above lists the mechanisms for setting this goal in descending order of precedence. To determine the optimization goal, the database server examines the settings in the order above. The first setting encountered determines the optimization goal. For example, if a query includes the ALL_ROWS directive but the OPT_GOAL configuration parameter is set to FIRST_ROWS, the database server optimizes for ALL_ROWS, as the query specifies.

Related reference:

[🔗 OPT_GOAL environment variable \(UNIX\) \(SQL Reference\)](#)

PC_HASHSIZE Configuration Parameter

onconfig.std *value*
31

range of values
Any positive integer, a prime number is recommended.

takes effect
When the database server is shut down and restarted

refer to Your IBM Informix Performance Guide

Use PC_HASHSIZE to specify the number of hash buckets in the caches that the database server uses.

PC_HASHSIZE applies to UDR cache only. For information on configuration parameters for other types of cache, see the “DS_POOLSIZ Configuration Parameter” on page 1-64 and the “DS_HASHSIZE Configuration Parameter” on page 1-60.

PC_POOLSIZ Configuration Parameter

onconfig.std *value*
127

default value
127

range of values

Any positive value from 127 to x , where x is dependent upon the shared memory configuration and available shared memory for the server instance.

takes effect

When the database server is shut down and restarted

refer to Your IBM Informix Performance Guide

PC_POOLSIZE specifies the maximum number of UDRs stored in the UDR cache.

For information on configuration parameters for other types of cache, see the “DS_POOLSIZE Configuration Parameter” on page 1-64 and the “DS_HASHSIZE Configuration Parameter” on page 1-60.

PHYSBUFF Configuration Parameter

onconfig.std value

PHYSBUFF 128

units Kilobytes

values An integer in the range of 4 - $(32767 * \text{pagesize} / 1024)$, where *pagesize* is the default system page size. The value must be evenly divisible by the default system page size. If the value is not evenly divisible by the page size, the database server rounds down the size to the nearest value that is evenly divisible by the page size.

takes effect

After you edit your onconfig file and restart the database server.

Usage

The PHYSBUFF configuration parameter specifies the size in kilobytes of the two physical-log buffers in shared memory. Double buffering permits user threads to write to the active physical-log buffer while the other buffer is being flushed to the physical log on disk. A write to the physical-log buffer is exactly one page in length. The value of the PHYSBUFF parameter determines how frequently the database server needs to flush the physical-log buffer to the physical-log file. If the RTO_SERVER_RESTART configuration parameter is enabled, use the 512 kilobyte default value for PHYSBUFF; if the value of the PHYSBUFF configuration parameter is less than 512 kilobytes, a warning message displays when you restart the server.

The user-data portion of a smart large object does not pass through the physical-log buffers.

Related concepts:

 [Physical-log buffer \(Administrator's Guide\)](#)

Related reference:

“**onstat -l** command: Print physical and logical log information” on page 21-193

PHYSFILE Configuration Parameter

Use the PHYSFILE configuration parameter to specify the size or location of the physical log file when you first initialize the disk space and bring the database server online.

onconfig.std *value*
50000
if not present
200
units Kilobytes
range of values
200 or more

takes effect

After the disk space has been initialized using the **oninit -i** command, the server does not dynamically implement changes that you make to the PHYSFILE configuration parameter. You can force the change, but that requires you to reinitialize the database server. Instead, if the database server is online, use the **onparams** utility to change the size or location of physical log file. You do not need to restart the server for the changes to take effect.

utilities

onparams -p

refer to The following topics in the *IBM Informix Administrator's Guide*:

- Sizing the physical log, in the chapter on the physical log
- Changing the physical-log location and size, in the chapter on managing the physical log

When the RTO_SERVER_RESTART configuration parameter is enabled, ensure that the value for the PHYSFILE configuration parameter is equal to at least 110% of the buffer pool size. A warning message prints to the message log when:

- The value for the PHYSFILE configuration parameter is changed to less than 110% of all of the buffer pools
- The server is restarted
- A new buffer pool is added

PLOG_OVERFLOW_PATH Configuration Parameter

onconfig.std *value*
On UNIX: \$INFORMIXDIR/tmp On Windows: None

if not present
\$INFORMIXDIR/tmp

takes effect

When the database server is brought up (shared memory is initialized)

refer to Your *IBM Informix Administrator's Guide*

The PLOG_OVERFLOW_PATH parameter specifies the location of the file that is used during fast recovery if the physical log file overflows. The file is **plog_extend.servernum** and by default located in \$INFORMIXDIR/tmp. Use the full pathname to specify a different location for the file with the PLOG_OVERFLOW_PATH parameter.

PN_STAGEBLOB_THRESHOLD configuration parameter

Use the PN_STAGEBLOB_THRESHOLD configuration parameter to reserve space for BYTE and TEXT data in round-robin fragments.

Set this configuration parameter to the typical or average size of the BYTE or TEXT data that is stored in the table.

Restriction: The PN_STAGEBLOB_THRESHOLD configuration parameter has no effect if the number of extents has reached the maximum extents allowed or if the dbspace is full.

When a table reaches the maximum number of pages for a fragment, more pages can be added to the table by adding a new fragment. However, if a table contains BYTE or TEXT columns and that table is fragmented by the round-robin distribution scheme, adding a new fragment does not automatically enable new rows to be inserted into the new fragment.

For example, if one of the fragments in the table reaches the maximum number of pages, adding a new fragment does not extend the table to store more rows. Because BYTE and TEXT data tend to be large in size, the data is *staged* in one of the fragments before being distributed evenly in all of the fragments. The staging fragment must have sufficient space to store the BYTE or TEXT data. Use the PN_STAGEBLOB_THRESHOLD configuration parameter so that the database server can stage the BYTE or TEXT data temporarily in a staging fragment until the INSERT operation is completed and the data is permanently stored in the table.

During a UPDATE operation if the fragment does not have the space that is specified in PN_STAGEBLOB_THRESHOLD configuration parameter the table row that is impacted by the updated is moved into another fragment.

onconfig.std *value*

None

if not present

0

syntax

PN_STAGEBLOB_THRESHOLD *value*

range of values

0 to 1000000

units Kilobytes

takes effect

When the database server is shut down and restarted

Related concepts:

 [Fragmentation by ROUND ROBIN \(Data Warehouse Guide\)](#)

PRELOAD_DLL_FILE Configuration Parameter

The PRELOAD_DLL_FILE configuration parameter specifies the path name for a shared library file that is preloaded when the database server is started.

You must specify a separate occurrence of this parameter for each library file that you want to preload. Use this parameter to preload the shared library files for the user-defined routines that are created in the C programming language (C UDRs).

onconfig.std *value*

None

takes effect

When the database server is started.

value Full path name for the shared library file. The following are some examples:

- /finance/jeffzhang/mylib.udr
- home/informix/extend/blade.so
- /deptxyz/udrs/geodetic.bld
- \work4\lauragupta\userfuncdir\cudrs.dll

utilities

onstat -g dll

Restriction: The PRELOAD_DLL_FILE configuration parameter is not supported by the **onmode -wm** command.

Restriction: A preloaded C UDR shared library remains active until the database instance is brought offline.

refer to onstat -g dll command. If the P flag is set, the shared library is preloaded on the server.

QSTATS Configuration Parameter

onconfig.std *value*
0

range of values

0 = Disable queue statistics 1 = Enable queue statistics

takes effect

When the database server is shut down and restarted

utilities

onstat -g qst

refer to

- “**onstat -g qst** command: Print wait options for mutex and condition queues” on page 21-141

QSTATS specifies the ability of **onstat -g qst** to print queue statistics.

RA_PAGES configuration parameter

Use the RA_PAGES configuration parameter to specify the number of disk pages to attempt to read ahead during sequential scans of data records. However, if the AUTO_READAHEAD configuration parameter is enabled, the database server ignores values set in the RA_PAGES configuration parameter.

onconfig.std *value*
64

if not present

4 if MULTIPROCESSOR is 0

8 if MULTIPROCESSOR is 1

units Number of data pages

range of values

4 to 4096. However, this value is also limited to the size of the bufferpool. For example, if the bufferpool has only 1000 pages, then the maximum value of the RA_PAGES configuration parameter is 1000.

takes effect

After you edit your `onconfig` file and restart the database server.

When you reset the value dynamically in your `onconfig` file by running the **`onmode -wf`** command.

When you reset the value for a session by running the **`onmode -wm`** command.

Usage

Read-ahead can greatly speed up database processing by compensating for the slowness of I/O processing relative to the speed of CPU processing. If the `AUTO_READAHEAD` configuration parameter is enabled, read ahead occurs automatically. Therefore, the server ignores information specified in the `RA_PAGES` configuration parameter.

The read-ahead threshold, which is the number of unprocessed data pages in memory that signals the database server to perform the next read-ahead, is one-half of the number of pages that is set for the `RA_PAGES` configuration parameter. If the `AUTO_READAHEAD` configuration parameter is set to 0, try setting the `RA_PAGES` configuration parameter to 64.

Related concepts:

 [Sequential scans \(Performance Guide\)](#)

Related reference:

“`onmode -wf, -wm`: Dynamically change certain configuration parameters” on page 15-26

“`AUTO_READAHEAD` configuration parameter” on page 1-30

 [Configure the database server to read ahead \(Administrator's Guide\)](#)

REMOTE_SERVER_CFG configuration parameter

Use the `REMOTE_SERVER_CFG` configuration parameter to specify the file that lists trusted remote hosts.

`onconfig.std` value

Not set

range of values

File name. The path is assumed to be `$INFORMIXDIR/etc`.

takes effect

After you edit your `onconfig` file and restart the database server.

When you reset the value dynamically in your `onconfig` file by running the **`onmode -wf`** command.

When you reset the value for a session by running the **`onmode -wm`** command.

Usage

The file specified by the `REMOTE_SERVER_CFG` configuration parameter must be located in `$INFORMIXDIR/etc`. If the configuration parameter is set, then the specified file is used instead of the `$INFORMIXDIR/etc/hosts.equiv` file. If the specified file does not exist in `$INFORMIXDIR/etc`, then client host names cannot be read.

The format of the file specified by the `REMOTE_SERVER_CFG` configuration parameter is the same as the format of the `$INFORMIXDIR/etc/hosts.equiv` file. If all the servers will trust the same set of remote servers, then the file can specify either file names or symbolic links. Alternatively, the same name can be used for `REMOTE_SERVER_CFG` in each remote server's `ONCONFIG` file.

Consider using the following naming convention for the file specified by the `REMOTE_SERVER_CFG` configuration parameter:

`servers.server_name`

Note: If the `sqlhosts` file of the database server uses the `s=6` option, you must also set the `S6_USE_REMOTE_SERVER_CFG` configuration parameter to 1 to use the file specified `REMOTE_SERVER_CFG` configuration parameter.

If the `sqlhosts` file of the database server uses the `s=6` option and the `S6_USE_REMOTE_SERVER_CFG` configuration parameter is not set or is set to 0, the database server uses the `$INFORMIXDIR/etc/hosts.equiv` file instead of the file specified `REMOTE_SERVER_CFG` configuration parameter.

Related concepts:

 [Trusted-host information \(Administrator's Guide\)](#)

Related reference:

“`onmode -wf, -wm`: Dynamically change certain configuration parameters” on page 15-26

“`S6_USE_REMOTE_SERVER_CFG` configuration parameter” on page 1-125

 [sqlhosts file and SQLHOSTS registry key options \(Administrator's Guide\)](#)

REMOTE_USERS_CFG configuration parameter

Use the `REMOTE_USERS_CFG` configuration parameter to specify the file that lists the names of trusted users that exist on remote hosts.

onconfig.std value
Not specified

range of values
File name. The path is assumed to be `$INFORMIX/etc`.

takes effect

After you edit your `onconfig` file and restart the database server.

When you reset the value dynamically in your `onconfig` file by running the **`onmode -wf`** command.

When you reset the value for a session by running the **`onmode -wm`** command.

Usage

The file specified by the `REMOTE_USERS_CFG` configuration parameter must be located in `$INFORMIXDIR/etc`. If the configuration parameter is set then the file specified is used instead of the `~/rhosts` file. If the specified file does not exist in `$INFORMIXDIR/etc`, then authentication will fail.

The format of the file specified by the `REMOTE_USERS_CFG` configuration parameter is the same as the format of the `~/rhosts` file.

Consider using the following naming convention for the file specified by the `REMOTE_USERS_CFG` configuration parameter:

`users.server_name`

Related concepts:

 Trusted-user information (Administrator's Guide)

Related reference:

“`onmode -wf, -wm`: Dynamically change certain configuration parameters” on page 15-26

RESIDENT configuration parameter

Use the `RESIDENT` configuration parameter to specify whether resident and virtual segments of shared memory remain resident in operating-system physical memory.

onconfig.std *value*

0

range of values

-1 to 99

0 = off

1 = lock the resident segment only

-1 = lock all resident and virtual segments

n = lock the resident segment and the next $n - 1$ virtual segments. For example, if you specify 99 as the value, the resident segment is locked and the next 98 virtual segments are locked.

Certain platforms have different values. For information, see your machine notes.

if not present

0

utilities

onmode -r (see “`onmode -n, -r`: Change shared-memory residency” on page 15-19)

takes effect

After you edit your `onconfig` file and restart the database server.

When you reset the value dynamically in your `onconfig` file by running the **onmode -wf** command.

When you reset the value for a session by running the **onmode -wm** command.

refer to The following topics in the *IBM Informix Administrator's Guide* for a discussion of residency:

- Resident portion of shared memory, in the shared-memory chapter
- Setting database server shared-memory configuration parameters, in the chapter on managing shared memory

Usage

Some systems allow you to specify that the resident portion of shared memory must stay (be resident) in memory at all times. If your operating system supports forced residency, you can specify that resident and virtual segments of shared memory not be swapped to disk.

Warning: Before you decide to enforce residency, verify that the amount of physical memory available is sufficient to execute all required operating-system and application processes. If insufficient memory is available, a system hang could result that requires a reboot.

On AIX, Solaris, or Linux systems that support large pages of memory, the DBSA can use operating system commands to configure a pool of large pages.

Informix can store non-message virtual memory segments on these large pages if you take the following steps:

- Enable large page sizes by setting the **IFX_LARGE_PAGES** environment variable.
- For virtual memory segments that you intend to store on large pages, set the **RESIDENT** parameter to lock those segments in physical memory, so that they cannot be swapped to disk

Storing virtual memory segments on large pages can offer significant performance benefits in large memory configurations. For more information about enabling Informix to use shared memory segments that are resident on large pages, see the description of **IFX_LARGE_PAGES** in the chapter about environment variables in your *IBM Informix Guide to SQL: Reference*.

Related reference:

“onmode -wf, -wm: Dynamically change certain configuration parameters” on page 15-26

 [IFX_LARGE_PAGES environment variable \(SQL Reference\)](#)

RESTARTABLE_RESTORE Configuration Parameter

onconfig.std *value*
ON

if not present
ON

range of values
OFF = restartable restore is disabled ON = restartable restore is enabled

takes effect
When the database server is shut down and restarted

refer to *IBM Informix Backup and Restore Guide*

If you set **RESTARTABLE_RESTORE** to ON, you enable the database server to restart a failed physical or cold logical restore at the point at which the failure occurred. To perform a restartable restore with ON-Bar, use the **onbar -RESTART** command.

Increase the size of your physical log if you plan to use restartable restore. For more information, see “**PHYSFILE** Configuration Parameter” on page 1-113.

Although a restartable restore slows down the logical restore if many logs need to be restored, you save a lot of time from not having to repeat the entire restore.

Important: If the database server fails during a warm logical restore, you must repeat the entire restore. If the database server is still running, use **onbar -r -l** to complete the restore.

If you do a cold restore on systems that are not identical, you can assign new pathnames to chunks, and you can rename devices for critical chunks during the restore. You must perform a level-0 archive after the rename and restore operation completes. For details, see the *IBM Informix Backup and Restore Guide*

The database server uses physical recovery and logical recovery to restore data as follows:

- **Physical recovery.** The database server writes data pages from the backup media to disk. This action leaves the storage spaces consistent to the point at which it was originally backed up. However, the backup times for each storage space are usually different. A restartable restore is restartable to the level of a storage space. If only some chunks of a storage space are restored when the restore fails, the entire storage space needs to be recovered again when you restart the restore.
- **Logical recovery.** The database server replays logical-log records on media to bring all the storage spaces up to date. At the end of logical recovery, all storage spaces are consistent to the same point.

RESTORE_POINT_DIR configuration parameter

Use the RESTORE_POINT_DIR configuration parameter to change the path name of the directory where restore point files will be placed during a failed upgrade to a new version of the server. Informix will store restore point files in a subdirectory of the specified directory, with the server number as the subdirectory name, only if the CONVERSION_GUARD configuration parameter is enabled.

onconfig.std *value*
\$INFORMIXDIR/tmp

range of values
complete path name for a directory

takes effect
When the database server is stopped and restarted

You can change the directory, for example, if you think that the \$INFORMIXDIR/tmp directory does not have enough space for restore point data. If you want to change the directory, you must change it before you initiate an upgrade to a new version of the server. You cannot change the directory during an upgrade.

The directory specified in the RESTORE_POINT_DIR configuration parameter must be empty when an upgrade begins. If the directory contains any restore point files from a previous upgrade, you must remove the files before a new upgrade begins a new restore point.

For information about the **onrestorept** utility, which you can use to undo changes made during a failed upgrade, see the *IBM Informix Migration Guide*.

ROOTNAME Configuration Parameter

onconfig.std value
rootdbs

units A dbspace

range of values

Up to 128 bytes. ROOTNAME must begin with a letter or underscore and must contain only letters, numbers, underscores, or \$ characters.

takes effect

When disk is initialized (destroys all data)

refer to Allocating disk space, in the chapter on managing disk space in the *IBM Informix Administrator's Guide*

ROOTNAME specifies a name for the root dbspace for this database server configuration.

The name must be unique among all dbspaces that the database server manages. It is recommended that you select a name that is easily recognizable as the root dbspace.

ROOTOFFSET Configuration Parameter

onconfig.std value
0

units Kilobytes

range of values

Any value greater than or equal to 0

takes effect

When disk is initialized (destroys all data)

refer to Allocating raw disk space on UNIX, in the chapter on managing disk space in the *IBM Informix Administrator's Guide*

ROOTOFFSET specifies the offset into an allocation of disk space (file, disk partition, or device) at which the initial chunk of the root dbspace begins.

UNIX Only:

On some UNIX platforms, it is not valid to set ROOTOFFSET to 0. When this parameter is set incorrectly, you must reinitialize disk space and reload data to resume proper operation of the database server. Before you configure the database server, always check your machine notes file for information about proper settings.

ROOTPATH Configuration Parameter

Use the ROOTPATH configuration parameter to specify the full pathname, including the device or filename, of the initial chunk of the root dbspace. The ROOTPATH configuration parameter is stored in the reserved pages as a chunk name.

onconfig.std value

On UNIX: \$INFORMIXDIR/tmp/demo_on.rootdbs

On Windows: None

range of values
Pathname

takes effect

When disk is initialized (destroys all data)

refer to The following material in the chapter on managing disk space in the *IBM Informix Administrator's Guide*

- Allocating disk space
- Creating links for raw devices

On UNIX, you must set the permissions of the file that you specify with the ROOTPATH configuration parameter to 660, and the owner and group must both be **informix**. On Windows, a member of the **Informix-Admin** group must own the file that you specify with the ROOTPATH configuration parameter.

UNIX Only:

If you use unbuffered disk space for your initial chunk on UNIX, you should define the ROOTPATH configuration parameter as a pathname that is a link to the initial chunk of the root dbspace instead of entering the actual device name for the initial chunk.

ROOTSIZE configuration parameter

Use the ROOTSIZE configuration parameter to specify the size in kilobytes of the initial chunk of the root dbspace. The size that you select depends on your immediate plans for your database server.

onconfig.std *value*
200000

if not present
0

units Kilobytes

range of values
50,000 through maximum capacity of the storage device

takes effect

When disk is initialized (destroys all data)

The database server uses the value of the ROOTSIZE configuration parameter only during a complete disk initialization. Changing the ROOTSIZE value after the initial chunk of the root dbspace has been created will have no effect.

Related concepts:

 Size of the root dbspace (Administrator's Guide)

RSS_FLOW_CONTROL Configuration Parameter

Specifies the boundaries within which flow control is enabled in a high-availability cluster that contains at least one RS secondary server.

onconfig.std *value*
0

range of values

Table 1-61. Valid values for the `RSS_FLOW_CONTROL` configuration parameter.

Value	Description
0	Flow control is activated when the difference between the current log position and the most recent acknowledged log exceeds eight times the size of the log buffer.
-1	Flow control is disabled. Disabling flow control might lead to wrapping of the log files and the loss of data.
<i>start_value, end_value</i>	The <i>start_value</i> and <i>end_value</i> parameters determine the amount of lag between the current log position and the last acknowledged log page. The values for <i>start_value</i> and <i>end_value</i> have a scaling factor of Kilobytes (K), Megabytes (M), or Gigabytes (G). For example, setting the <code>RSS_FLOW_CONTROL</code> configuration parameter to <code>128M,100M</code> starts RSS flow control when the lag between the logs is 128 megabyte and stops flow control when the log lag has dropped to 100 megabytes. The <i>start_value</i> must be greater than the <i>end_value</i> .

takes effect

When the database server is stopped and restarted or when the `RSS_FLOW_CONTROL` value is changed by using **`onmode -wm`** or **`onmode -wf`**.

utilities

`onmode -wf` or **`onmode -wm`**

refer to

- “`onmode -wf, -wm`: Dynamically change certain configuration parameters” on page 15-26

Flow control provides a way to limit log activity on the primary server so that RS secondary servers in the cluster do not fall too far behind on processing transactions. When flow control is enabled, and when the difference in log size between the current log position and the last acknowledged log page exceeds the value set by *start_value*, then log activity on the primary server becomes restricted. Users connected to the primary server may experience slower response time when flow control is active.

The `RSS_FLOW_CONTROL` configuration parameter allows you to configure when flow control is started or stopped. You set the `RSS_FLOW_CONTROL` configuration parameter on the primary server only. All RS secondary servers in the cluster are affected by the `RSS_FLOW_CONTROL` configuration parameter.

Flow control is started when the lag between the logs is greater than the *start_value* parameter and stops flow control when the log lag has dropped to the value set by the *stop_value* parameter.

Enabling flow control ensures that logs on RS secondary servers remain current if the RS secondary servers are situated on a busy or intermittent network. Logs are always sent to the RS secondary server in the order in which they were received.

Related reference:

“onmode -wf, -wm: Dynamically change certain configuration parameters” on page 15-26

RTO_SERVER_RESTART configuration parameter

Use the RTO_SERVER_RESTART configuration parameter to specify recovery time objective (RTO) standards for the amount of time, in seconds, that Informix has to recover from a problem after you restart the server and bring it into online or quiescent mode.

onconfig.std *value*
0 (disabled)

units seconds

range of values
0 = disabled
60 to 1800

takes effect

After you edit your onconfig file and restart the database server.

When you reset the value dynamically in your onconfig file by running the **onmode -wf** command.

When you reset the value for a session by running the **onmode -wm** command.

utilities

oncheck -pr

onparams

refer to

- Nonblocking checkpoints information in *IBM Informix Administrator's Guide*
- Effects of configuration on I/O activity in *IBM Informix Enterprise Replication guide*

Related reference:

“onmode -wf, -wm: Dynamically change certain configuration parameters” on page 15-26

S6_USE_REMOTE_SERVER_CFG configuration parameter

The S6_USE_REMOTE_SERVER_CFG configuration parameter controls whether the file specified by the REMOTE_SERVER_CFG configuration parameter is used to authenticate secure connections for server clusters.

onconfig.std *value*
Not set

if not present
0

range of values

- 0 = The \$INFORMIXDIR/etc/hosts.equiv file is used to authenticate servers connecting through a secure port.

- 1 = The file specified by the REMOTE_SERVER_CFG configuration parameter is used to authenticate servers connecting through a secure port.

takes effect

After you edit your onconfig file and restart the database server.

When you reset the value dynamically in your onconfig file by running the **onmode -wf** command.

When you reset the value for a session by running the **onmode -wm** command.

Usage

The REMOTE_SERVER_CFG configuration parameter is used to specify a file that lists the remote server hosts that are trusted by the computer housing the database server. If one or more of the listed servers are configured using the sqlhosts file connection-security option `s=6`, then you must set the S6_USE_REMOTE_SERVER_CFG configuration parameter to 1.

If S6_USE_REMOTE_SERVER_CFG is unset or set to 0, the \$INFORMIXDIR/etc/hosts.equiv file, rather than the file specified by the REMOTE_SERVER_CFG configuration parameter, is used to authenticate servers connecting through a secure port.

Related reference:

“REMOTE_SERVER_CFG configuration parameter” on page 1-117

“S6_USE_REMOTE_SERVER_CFG configuration parameter” on page 1-125

“onmode -wf, -wm: Dynamically change certain configuration parameters” on page 15-26

 sqlhosts file and SQLHOSTS registry key options (Administrator's Guide)

SB_CHECK_FOR_TEMP configuration parameter

Use the SB_CHECK_FOR_TEMP configuration parameter to prevent the copying of a temporary smart large object into a permanent table.

By default, you can copy temporary smart large objects into permanent tables. Smart large object data types, BLOB and CLOB, consist of two parts: the data, which is stored in an sbspace, and the handle, which is stored in a table. When you copy a temporary smart large object into a permanent table, only the BLOB or CLOB handle is copied into the permanent table. If you subsequently drop the temporary smart large object, the permanent table contains a handle that is no longer valid.

To prevent the copying of a temporary smart large object into a permanent table, set the SB_CHECK_FOR_TEMP configuration parameter to 1 in the **onconfig** file. For example, if the SB_CHECK_FOR_TEMP configuration parameter is set to 1, an INSERT INTO . . . SELECT FROM . . . statement that copies a temporary smart large object into a permanent table fails.

onconfig.std *value*
None

if value not present

The copying of temporary smart large objects into permanent tables is permitted.

range of values

- 0 = Permit the copying of temporary smart large objects into permanent tables. Equivalent to the configuration parameter not being set in the **onconfig** file.
- 1 = Prevent the copying of temporary smart large objects into permanent tables. The database server returns the following error messages instead of copying the handle of a temporary smart large object:
 - -9810: Smart-large-object error.
 - -12246: Smart large objects: You cannot put a temporary smart large object into a permanent table

takes effect

When the database server is shut down and restarted

SBSPACENAME configuration parameter

Use the SBSPACENAME configuration parameter specifies the name of the default sbspace.

onconfig.std *value*

None

if not present

0

range of values

Up to 128 bytes. SBSPACENAME must be unique, begin with a letter or underscore, and contain only letters, digits, underscores, or \$ characters.

utilities

onspaces -c -S

takes effect

After you edit your onconfig file and restart the database server.

When you reset the value dynamically in your onconfig file by running the **onmode -wf** command.

When you reset the value for a session by running the **onmode -wm** command.

refer to

- Using **onspaces** to “onspaces -c -S: Create an sbspace” on page 20-11
- “SBSPACETEMP configuration parameter” on page 1-128
- “SYSSBSPACENAME configuration parameter” on page 1-157
- “Sbspace Structure” on page 4-24
- What is an sbspace, in the chapter on data storage in the *IBM Informix Administrator's Guide*
- Altering sbspace characteristics, in the chapter on managing data on disk in the *IBM Informix Administrator's Guide*
- Assigning a smart large object to an sbspace, in the section on the CREATE TABLE and ALTER TABLE statements, in the *IBM Informix Guide to SQL: Syntax*
- Creating an sbspace for Enterprise Replication usage, in the IBM Informix Enterprise Replication guide
- Using multirepresentational data, in the *IBM Informix DataBlade API Programmer's Guide*

Usage

If your database tables include smart-large-object columns that do not explicitly specify a storage space, that data is stored in the sbspace that SBSPACENAME specifies. The default sbspace is also used by the built-in encryption and decryption functions to store BLOB or CLOB values. If DECRYPT_BINARY or an encryption function cannot find an sbspace in which to store a BLOB or CLOB argument or returned value, the function fails with the following error message:
Fatal error in server row processing - SQL error -9810 ISAM error -12053

If you see this error message after you invoke an encryption or decryption function that has a CLOB or BLOB argument, configure a default sbspace using the SBSPACENAME configuration parameter, and then repeat the function call.

You must create the default sbspace with the **onspaces -c -S** utility before you can use it. The database server validates the name of the default sbspace when one of the following occurs:

- You specify the default sbspace as the storage option for a CLOB or BLOB column in the PUT clause of the CREATE TABLE or ALTER TABLE statement.
- The database server attempts to write a smart large object to the default sbspace when no sbspace was specified for the column.
- You store multirepresentational data in the default sbspace.

JAVA Language Support:

If you are using IBM Informix Dynamic Server with J/Foundation, you must provide a smart large object where the database server can store the Java archive (JAR) files. These JAR files contain your Java user-defined routines (UDRs). It is suggested that when you use Java UDRs, you create separate sbspaces for storing smart large objects.

Warning: When you use Enterprise Replication, you must set the *CDR_QDATA_SBSPACE* parameter and create the sbspace before you define the replication server.

Automatic creation of the default sbspace

Under certain circumstances, a default sbspace is created even if the SBSPACENAME configuration parameter is not set:

- If you create a **bts** index and do not explicitly specify an sbspace name
- If you create a table with a spatial data type column and do not explicitly specify an sbspace name

The default sbspace is created in the root dbspace for the database server with a size of 10 000 KB. You must manually increase the size of the default sbspace when it fills.

SBSPACETEMP configuration parameter

Use the SBSPACETEMP configuration parameter to specify the name of the default temporary sbspace for storing temporary smart large objects without metadata or user-data logging. If you store temporary smart large objects in a standard sbspace, the metadata is logged.

onconfig.std *value*

None

if not present

Temporary smart large objects are stored in a standard sbspace.

range of values

Up to 128 bytes. SBSPACETEMP must be unique, begin with a letter or underscore, and contain only letters, digits, underscores, or \$ characters.

utilities

onspaces

takes effect

After you edit your onconfig file and restart the database server.

When you reset the value dynamically in your onconfig file by running the **onmode -wf** command.

When you reset the value for a session by running the **onmode -wm** command.

refer to

- “onspaces -c -S: Create an sbspace” on page 20-11
- “SBSPACENAME configuration parameter” on page 1-127
- Temporary sbspaces, in the chapter on data storage in the *IBM Informix Administrator's Guide*
- Creating a temporary sbspace, in the chapter on managing disk space in the *IBM Informix Administrator's Guide*
- Using temporary smart large objects, in the *IBM Informix DataBlade API Programmer's Guide*

SDS_ENABLE Configuration Parameter

onconfig.std *value*

None

if not present

0

range of values

0, 1 0 = disable, 1 = enable

takes effect

When database server is shut down and restarted.

refer to

- *Using Shared Disk Secondary Servers* in the *IBM Informix Administrator's Guide*.

SDS_ENABLE enables SD secondary server functionality. You must set SDS_ENABLE to 1 (enable) on the SD secondary server to enable SD secondary server functionality.

SDS_ENABLE is set to 1 (enabled) automatically when you run the following command:

```
onmode -d set SDS primary
```

SDS_ENABLE is set to 0 (disabled) when you run the following command:

```
onmode -d clear SDS primary
```

To prevent data corruption, you cannot use the **oninit -i** or **oninit -iy** command to initialize disk space on a server if SDS_ENABLE is set to 1 (enabled). To initialize an SD secondary server, initialize only the shared memory by using **oninit** with no parameters. To initialize a primary server to which one or more SD secondary servers are attached, and whose disk has never been initialized, set SDS_ENABLE to 0 and initialize the server memory and disk using **oninit -i**. To initialize a primary server to which SD secondary servers are attached, and whose disk is already initialized, set SDS_ENABLE to 1 and initialize shared memory only using **oninit** with no parameters. See Chapter 13, “The oninit utility,” on page 13-1.

SDS_LOGCHECK configuration parameter

Use the SDS_LOGCHECK configuration parameter to determine whether the primary server is generating log activity and to allow or prevent failover of the primary server.

For example, if the SDS_LOGCHECK configuration parameter is set to 10, and the primary server fails, the SD secondary server waits up to 10 seconds to either detect that the primary server is generating log records (in which case failover is prevented), or the SD secondary server detects that the primary is not generating log records and failover occurs.

onconfig.std *value*

0

if not present

0

units Seconds

range of values

0 = Do not detect log activity; allow failover.

n = Wait up to *n* seconds. If log activity is detected from the primary server, failover is prevented; otherwise, failover is allowed.

takes effect

When shared disk functionality is enabled on the primary server

refer to

- *Using shared disk secondary servers in the IBM Informix Administrator's Guide*

The SDS_LOGCHECK configuration parameter specifies the amount of time in seconds that the SD secondary server waits to detect whether the primary server is generating log activity. If there is no log activity generated by the primary server in the specified amount of time, failover processing is allowed to start. If log activity from the primary server is detected, failover processing is not started.

Set the SDS_LOGCHECK configuration parameter to a value greater than zero if you do not have I/O fencing configured and your system consists of a primary server and one or more SD secondary servers.

If your system has I/O fencing configured, and if an SD secondary server becomes a primary server, the I/O fencing script must prevent the failed primary server from updating any of the shared disks. If the system does not have I/O fencing configured, the SDS_LOGCHECK configuration parameter prevents the occurrence

of multiple primary servers by not failing over to the SD secondary server if the original primary server is generating log records.

SDS_PAGING Configuration Parameter

The SDS_PAGING configuration parameter specifies the location of two files that serve as buffer paging files.

onconfig.std value
None

takes effect
When SD secondary server is started

refer to

- *Using Shared Disk Secondary Servers* in the *IBM Informix Administrator's Guide*.

Set the SDS_PAGING configuration parameter to the paths of two buffer paging files separated by a comma. The SDS_PAGING configuration parameter must be set to a valid value to ensure that the SD secondary server starts. Because the paging files grow dynamically as needed, you should allocate enough disk space to store two times the size of the value specified by the PHYFILE configuration parameter (see "PHYFILE Configuration Parameter" on page 1-113)

SDS_TEMPDBS Configuration Parameter

Use the SDS_TEMPDBS configuration parameter to specify information that the shared disk (SD) secondary server uses to dynamically create temporary dbspaces. This configuration parameter can be specified only on the SD secondary server.

onconfig.std value

Not set. Temporary dbspaces for shared disk secondary servers are not created.

values A string containing the following values in the following order, separated by commas:

dbspace = The name of the dbspace to create. Must be unique among all existing dbspaces, blobspaces, and sbspaces, including those any temporary spaces that are inherited from a primary server. The name cannot exceed 128 bytes. It must begin with a letter or underscore and must contain only letters, numbers, underscores, or the \$ character.

dbpath = The path for the dbspace, either a full path name or a relative path name. If you use a relative path name, it must be relative to the directory that was the current directory when you initialized the database server.

pagesize = An integer representing the page size of the dbspace, in kilobytes. The page size must be between 2 KB and 16 KB and must be a multiple of the default page size.

offset = An integer equal to or greater than 0 that specifies offset into the disk partition or into the device to reach the initial chunk of the dbspace. The starting offset plus the chunk size cannot exceed the maximum chunk size. The offset must be a multiple of the page size. The maximum offset is 2 or 4 terabytes, depending on the platform. By default, the value is in

kilobytes. You can designate different units by appending a single character modifier to the value: M or m for megabytes, G or g for gigabytes, or T or t for terabytes.

size = A positive integer equal to or greater than 1000 kilobytes and a multiple of the page size that specifies the size of the initial chunk of the dbspace. The value of *offset* plus the value of *size* cannot exceed the maximum chunk size. The maximum size of a chunk is equal to 2 147 483 647 pages multiplied by the page size. By default, the value is in kilobytes. You can designate different units by appending a single character modifier to the value: M or m for megabytes, G or g for gigabytes, or T or t for terabytes.

separators

Separate each value with a comma. Do not use blank spaces.

takes effect

After you edit your onconfig file and restart the SD secondary server.

Usage

The temporary dbspaces are created, or initialized if the dbspaces existed previously, when the SD secondary server starts. The temporary dbspaces are used for creating temporary tables. There must be at least one occurrence of the SDS_TEMPDBS configuration parameter in the onconfig file of the SD secondary server for the SD secondary server to start. You can specify up to 16 SD secondary temporary dbspaces in the onconfig file by using multiple occurrences of the SDS_TEMPDBS configuration parameter.

For each occurrence of the SDS_TEMPDBS configuration parameter in the onconfig file:

- The *dbsname* value must be unique for each server and not shared with any other SD secondary server or the primary server.
- The combination of *dbspath*, *pagesize*, *offset*, and *size* must not cause any overlap with existing chunks or between temporary dbspaces spaces specified by the SDS_TEMPDBS configuration parameter.
- The *pagesize* value must be the same for each SDS_TEMPDBS configuration parameter value.

The following example shows two entries for the SDS_TEMPDBS configuration parameter:

```
SDS_TEMPDBS sds_space1,/dev/raw_dev1,2,0,60M
SDS_TEMPDBS sds_space2,/dev/raw_dev2,2,0,80M
```

If the primary server in a high-availability cluster fails and an SD secondary server takes over as the primary server, then the value set for the SDS_TEMPDBS configuration parameter on the SD secondary server is used for temporary dbspaces until the server is restarted. You should ensure that the value specified for the SDS_TEMPDBS configuration parameter on the SD secondary server is different than the value specified on the primary server. After the SD secondary server is restarted, the DBSPACETEMP configuration parameter is used.

Related concepts:

 [Shared disk secondary servers \(Administrator's Guide\)](#)

SDS_TIMEOUT configuration parameter

Use the SDS_TIMEOUT configuration parameter to specify the amount of time in seconds that the primary server will wait for a log position acknowledgment to be sent from the SD secondary server.

onconfig.std *value*

20

if not present

10

range of values

2 to 2147483647

units seconds

takes effect

After you edit your onconfig file and restart the database server.

When you reset the value dynamically in your onconfig file by running the **onmode -wf** command.

When you reset the value for a session by running the **onmode -wm** command.

refer to

- *Using Shared Disk Secondary Servers* in the *IBM Informix Administrator's Guide*.

Usage

If there is no log position acknowledgment received from the SD secondary server in the specified amount of time, the primary server will disconnect from the SD secondary server and continue. After waiting for the number of seconds specified in the Use the SDS_TIMEOUT configuration parameter to specify the amount of time in seconds that the primary server will wait for a log position acknowledgment to be sent from the SD secondary server configuration parameter, the primary server will start removing SD secondary servers if page flushing has timed out while waiting for an SD secondary server.

Related reference:

"onmode -wf, -wm: Dynamically change certain configuration parameters" on page 15-26

SECURITY_LOCALCONNECTION Configuration Parameter

onconfig.std *value*

None

range of values

- 0 = No security checking occurs.
- 1 = Informix checks whether the ID of the user who is running the program matches the ID of the user who is trying to connect to the database

- 2 = same as 1, plus Informix retrieves the peer port number from the network API and verifies that the connection is coming from the client program. You can only specify 2 if your system has SOCTCP or IPCSTR network protocols.

takes effect

When the database server is shut down and restarted

refer to Role of the SERVERNUM configuration parameter, in the multiple-residency chapter of the *IBM Informix Administrator's Guide*

SECURITY_LOCALCONNECTION lets you verify security on local connections by verifying that the ID of the local user who is running a program is the same ID of the user who is trying to access the database.

SEQ_CACHE_SIZE configuration parameter

Use the SEQ_CACHE_SIZE configuration parameter to specify the maximum number of sequence objects that can have preallocated values in the sequence cache.

If SEQ_CACHE_SIZE configuration parameter is not set, then by default you cannot define more than 10 different sequence objects with the CACHE option of the CREATE SEQUENCE statement.

onconfig.std *value*
10

default value
10

range of values
1 to 2147483647

takes effect
When the database server is stopped and restarted

For example, if you want to increase the maximum number of sequence objects that can have preallocated values to 15, specify:

```
SEQ_CACHE_SIZE 15
```

SERVERNUM configuration parameter

The SERVERNUM configuration parameter specifies a relative location in shared memory.

The value that you choose must be unique for each database server on your local computer. The value does not need to be unique on your network. Because the value 0 is included in the **onconfig.std** file, it is suggested that you choose a value other than 0 to avoid the inadvertent duplication of the SERVERNUM configuration parameter.

onconfig.std *value*
0

range of values
0 through 255

takes effect
When the database server is shut down and restarted

refer to Role of the SERVERNUM configuration parameter, in the multiple-residency chapter of the *IBM Informix Administrator's Guide*

SHMADD configuration parameter

Use the SHMADD configuration parameter to specify the size of a segment that is dynamically added to the virtual portion of shared memory.

onconfig.stdvalue
8192

range of values

32-bit platforms: 1024 through 524288 64-bit platforms: 1024 through 4294967296

units Kilobytes

takes effect

After you edit your onconfig file and restart the database server.

When you reset the value dynamically in your onconfig file by running the **onmode -wf** command.

When you reset the value for a session by running the **onmode -wm** command.

utilities

onstat -g seg (Use the **onstat -g seg** command to display the number of shared-memory segments that the database server is currently using. For more information, see “**onstat -g seg** command: Print shared memory segment statistics” on page 21-161)

refer to The following material in the *IBM Informix Administrator's Guide*:

- Virtual portion of shared memory, in the shared-memory chapter
- Monitoring shared-memory segments with **onstat -g seg**, in the managing memory chapter

Usage

It is more efficient to add memory in large segments, but wasteful if the added memory is not used. Also, the operating system might require you to add memory in a few large segments rather than many small segments.

The following table contains recommendations for setting the initial value of SHMADD.

Amount of Physical Memory	Recommended SHMADD Value
Less than 256 megabytes	8192
Between 256 megabytes and 512 megabytes	16,384
Greater than 512 megabytes	32,768

Related reference:

“onmode -wf, -wm: Dynamically change certain configuration parameters” on page 15-26

“EXTSHMADD configuration parameter” on page 1-78

SHMBASE Configuration Parameter

onconfig.std *value*

Platform dependent

units Address

range of values

Positive integers

takes effect

When the database server is shut down and restarted

utilities

To see the shared-memory segment addresses, use the **onstat -g seg** command.

refer to Setting operating-system shared-memory configuration parameters, in the chapter on managing shared memory in the *IBM Informix Administrator's Guide*

SHMBASE specifies the base address where shared memory is attached to the memory space of a virtual processor. The addresses of the shared-memory segments start at the SHMBASE value and grow until the upper-bound limit, which is platform specific.

Do not change the value of SHMBASE. The **onconfig.std** value for SHMBASE depends on the platform and whether the processor is 32-bit or 64-bit. For information on which SHMBASE value to use, see the machine notes.

SHMNOACCESS Configuration Parameter

onconfig.std *value*

On UNIX: None

On Windows: #SHMNOACCESS 0x70000000-0x7FFFFFFF, and this value is commented out in the onconfig.std template file.

separators

Comma

range of values

From one to ten address ranges

takes effect

When the database server is shut down and restarted

The SHMNOACCESS configuration parameter specifies a virtual memory address range to **not** use to attach shared memory. SHMNOACCESS is used to avoid specific range process addresses, which in turn avoids conflicts with operating system libraries.

Each address in each range must start in hexadecimal format. Each address in a range must be separated by a hyphen and each range must be separated by a comma, as the following example shows:

SHMNOACCESS 0x70000000-0x75000000,
0x7A000000-0x80000000

SHMTOTAL configuration parameter

Use the SHMTOTAL configuration parameter to specify the total amount of shared memory (resident, virtual, communications, and virtual extension portions) to be used by the database server for all memory allocations. The **onconfig.std** value of 0 implies that no limit on memory allocation is stipulated.

onconfig.std *value*

0

units Kilobytes

range of values

0 (= no specific limit) or any integer greater than or equal to 1

takes effect

When the database server is shut down and restarted

refer to How much shared memory the database server needs, in the shared-memory chapter of the *IBM Informix Administrator's Guide*

The SHMTOTAL configuration parameter enables you to limit the demand for memory that the database server can place on your system. However, applications might fail if the database server requires more memory than the limit imposed by SHMTOTAL. When this situation occurs, the database server writes the following message in the message log:

```
size of resident + virtual segments xx + yy > zz total allowed by  
configuration parameter SHMTOTAL
```

This message includes the following values.

Value	Description
--------------	--------------------

xx	Current size of resident segments
-----------	-----------------------------------

yy	Current size of virtual segments
-----------	----------------------------------

zz	Total shared memory required
-----------	------------------------------

If you enabled the LOW_MEMORY_MGR configuration parameter and are configuring the server to use a percentage of the SHMTOTAL value for automatic low memory management start and stop thresholds, use caution when changing the value of SHMTOTAL. Changing the value of the SHMTOTAL configuration parameter value can cause the configuration of automatic low memory management to become invalid, forcing the database server to use the default settings.

UNIX Only:

Set the operating-system parameters for maximum shared-memory segment size, typically SHMMAX, SHMSIZE, or SHMALL, to the total size that your database server configuration requires. For information on the amount of shared memory that your operating system allows, see the machine notes.

Related concepts:

 Shared-memory size (Administrator's Guide)

Related reference:

“DS_TOTAL_MEMORY configuration parameter” on page 1-64

“LOW_MEMORY_MGR configuration parameter” on page 1-91

“scheduler Imm enable argument: Specify automatic low memory management settings (SQL administration API)” on page 22-102

SHMVIRT_ALLOCSEG configuration parameter

Use the SHMVIRT_ALLOCSEG configuration parameter to specify a threshold at which Informix should allocate a new shared memory segment and the level of the event alarm activated if the server cannot allocate the new memory segment.

onconfig.std value

SHMVIRT_ALLOCSEG 0,3

values A numeric value optionally followed by a comma and another numeric value.

threshold = A number that indicates when the database server should add a shared memory segment:

- 0 = Default. The database server allocated shared memory segments when needed.
- .40 - .99 = The percentage of memory used before a segment is added.
- 256 - 10000000 = The number of kilobytes remaining before a segment is added.

alarm_level: Optional. An integer value from 1 to 5 that specifies the level of the event alarm to raise: 1 = Not noteworthy, 2 = Information, 3 = Attention (Default), 4 = Emergency, 5 = Fatal. The event alarm has a class ID of 24 and an event ID of 24003.

separator

Separate the values with a comma.

takes effect

After you edit your onconfig file and restart the database server.

Usage

Set the SHMVIRT_ALLOCSEG configuration parameter to proactively add shared memory segments instead of waiting until the database server automatically adds shared memory segments.

The event alarm repeats every thirty minutes if a new memory segment cannot be allocated.

Related concepts:

 The SHMVIRT_ALLOCSEG configuration parameter and memory utilization (Performance Guide)

Related reference:

“Event Alarm Parameters” on page C-4

SHMVIRTSIZE configuration parameter

Use the SHMVIRTSIZE configuration parameter to specify the initial size of a virtual shared-memory segment.

onconfig.std *value*

32656

if not present

- If SHMADD is present: SHMADD
- If SHMADD is not present: 8192

units Kilobytes

range of values

32-bit platforms: Positive integer with a maximum value of 2 gigabytes

64-bit platforms: Positive integer with a maximum value of 4 terabytes

The maximum value might be less on some platforms due to operating-system limitations. For the actual maximum value for your UNIX platform, see the machine notes.

takes effect

When the database server is shut down and restarted

utilities

onstat -g seg (see “**onstat -g seg** command: Print shared memory segment statistics” on page 21-161)

refer to

- Virtual portion of shared memory, in the shared-memory chapter of the *IBM Informix Administrator's Guide*
- Chapter on configuration effects on memory utilization, in your *IBM Informix Performance Guide*

To determine the appropriate value for the SHMVIRTSIZE configuration parameter, use the following algorithm to determine the size of the virtual portion of shared memory:

$shmvirtualsize = fixed\ overhead + ((stack\ size + heap) * number\ of\ users)$

Component	Value to use
Fixed overhead	<p>This includes the size of the AIO vectors + sort memory + dbspace backup buffers + dictionary size + size of stored-procedure cache + histogram pool + other pools, and other overhead.</p> <p>To obtain an estimate of the fixed overhead, start the database server and see how many additional memory segments are allocated, if any. The number of users that you have on the system when you start the server, impacts the allocation of memory segments. When you start the server:</p> <ul style="list-style-type: none"> • If the number of users is typical for your environment, then add the size of the memory segments to the current value for the SHMVIRTSIZE configuration parameter and restart the server. • If the number of users is far less than what is typical for your environment, you must calculate the appropriate overhead value to use for the memory segments. You can determine how many memory segments each user will consume by dividing the number of additional memory segments allocated when you started the server by the number of users that you had on the server at that time. Multiply the value for the memory segments for each user by the number of users that you will typically have on the system. Add this calculated value for the memory segments to the current value for SHMVIRTSIZE configuration parameter and restart the server.
Stack size	<p>On 32-bit systems, use 32 kilobytes for the stack size. Typically on 64-bit systems, you use 64 kilobytes for the stack size. However, some 64-bit systems use a different value. For more information see the STACKSIZE configuration parameter.</p>
Heap	<p>Use 30 kilobytes per user.</p>
Number of users	<p>Use the maximum number of concurrent user sessions that you anticipate on the server.</p>

If possible, create a virtual portion of shared memory of a size that is more than you require for your daily processing.

Use the **onstat -g seg** command to determine peak usage and lower the value of the SHMVIRTSIZE configuration parameter accordingly.

Related reference:

“DS_TOTAL_MEMORY configuration parameter” on page 1-64

“LOW_MEMORY_RESERVE configuration parameter” on page 1-92

SINGLE_CPU_VP configuration parameter

onconfig.std *value*

0

range of values

0 = running with multiple CPU VPs

Any nonzero value = running with one CPU VP

takes effect

When the database server is shut down and restarted

refer to Running on a single-processor computer, in the chapter on virtual processors in the *IBM Informix Administrator's Guide*

SINGLE_CPU_VP specifies whether or not the database server is running with only one CPU virtual processor.

Disable the SINGLE_CPU_VP configuration parameter by setting it to 0 if you want the number of CPU VPs to be automatically increased when the database server starts.

Setting SINGLE_CPU_VP to nonzero allows the database server to use optimized code based on the knowledge that only one CPU virtual processor is running. It enables the database server to bypass many of the mutex calls that it must use when it runs multiple CPU virtual processors.

It is strongly recommended that you set this parameter when the database server will run only one CPU virtual processor. Depending on the application and workload, setting this parameter can improve performance by up to 10 percent.

If you set SINGLE_CPU_VP to nonzero and try to add a CPU virtual processor, you receive one of the following messages:

onmode: failed when trying to change the number of *classname* VPs by *n*.

onmode: failed when trying to change the number of cpu virtual processors by *n*.

If you set SINGLE_CPU_VP to nonzero and then attempt to bring up the database server with VPCLASS **cpu**, *num* set to a value greater than 1, you receive the following error message, and the database server initialization fails:

Cannot have SINGLE_CPU_VP non-zero and CPU VPs greater than 1.

Related concepts:

 Automatic addition of CPU virtual processors (Performance Guide)

VPCLASS Values and the SINGLE_CPU_VP Configuration Parameter

Informix treats user-defined virtual-processor classes as if they were CPU virtual processors. If you set the *SINGLE_CPU_VP* configuration parameter to a nonzero value, you cannot create any user-defined virtual-processor classes.

Using a user-defined VPCLASS

If you set this configuration parameter to a nonzero value and then attempt to bring up the database server with a user-defined VPCLASS, you receive the following error message, and the database server initialization fails:

```
oninit: Cannot have SINGLE_CPU_VP non-zero and user-defined VP classes
```

Using the *cpu* VPCLASS

If you set this configuration parameter to a nonzero value and then attempt to bring up the database server with the VPCLASS *cpu* value for *num* set to a value greater than 1, you receive the following error message, and the database server initialization fails:

```
Cannot have SINGLE_CPU_VP non-zero and CPU VPs greater than 1.
```

SMX_COMPRESS configuration parameter

Use the SMX_COMPRESS configuration parameter to specify the level of compression that the database server uses before sending data from the source database server to the target database server.

Network compression saves network bandwidth over slow links but uses more CPU to compress and decompress the data. The SMX_COMPRESS configuration parameter values of the two servers are compared and changed to the higher compression values.

onconfig.std *value*

0

range of values

- -1 specifies no compression
- 0 specifies that data is compressed only if the target server expects compression
- 1 through 9 specifies increasing levels of compression

takes effect

After you edit your onconfig file and restart the database server.

When you reset the value dynamically in your onconfig file by running the **onmode -wf** command.

When you reset the value for a session by running the **onmode -wm** command.

Usage

The SMX_COMPRESS configuration parameter values have the following meanings:

Value	Meaning
-1	The source database server never compresses the data, regardless of whether or not the target site uses compression.
0	The source database server compresses the data only if the target database server expects compressed data.
1	The database server performs a minimum amount of compression.

Value	Meaning
9	The database server performs the maximum possible compression.

Related reference:

“onmode -wf, -wm: Dynamically change certain configuration parameters” on page 15-26

SP_AUTOEXPAND configuration parameter

Use the SP_AUTOEXPAND configuration parameter to enable or disable the automatic creation or extension of chunks.

onconfig.std value
1

default value
1

range of values
0 = The automatic creation or extension of chunks is not enabled.
1 = The automatic creation or extension of chunks is enabled.

takes effect

After you edit your onconfig file and restart the database server.

When you reset the value dynamically in your onconfig file by running the **onmode -wf** command.

When you reset the value for a session by running the **onmode -wm** command.

When the SP_AUTOEXPAND configuration parameter is enabled and a storage container such as a dbspace has a defined create size or extend size that is not zero, the container is auto-expandable.

Related reference:

“onmode -wf, -wm: Dynamically change certain configuration parameters” on page 15-26

SP_THRESHOLD configuration parameter

Use the SP_THRESHOLD configuration parameter to define the minimum amount of free kilobytes that can exist in a storage space before Informix automatically runs a task to expand the space, either by extending an existing chunk in the space or by adding a new chunk.

onconfig.std value
0

default value
0

range of values
0 = No threshold. The trigger that runs the storage space monitoring (**mon_low_storage**) task for adding space when space is below the threshold is disabled.
1 to 50 = A threshold that is a percentage of free kilobytes in a storage space.

If the value is 50 or below, Informix interprets the value as a percentage (for example, 10 = 10 percent and 2.84 = 2.84 percent).

1000 to the maximum size of a chunk = A threshold that is either 1000 kilobytes or the maximum size of the chunk on the current platform. If the value is 1000 or higher, Informix interprets the value as a specific number of kilobytes.

takes effect

After you edit your `onconfig` file and restart the database server.

When you reset the value dynamically in your `onconfig` file by running the `onmode -wf` command.

When you reset the value for a session by running the `onmode -wm` command.

Values between 50 and 1000 are not valid.

When you set the `SP_THRESHOLD` configuration parameter to a valid value that is greater than 0, the built-in Scheduler task, `mon_low_storage`, runs automatically when the free space in a dbspace, temporary dbspace, sbspace, temporary sbspace, or blobspace falls below the threshold.

Suppose the value of the `SP_THRESHOLD` configuration parameter value is 5.5, which the server interprets as 5.5 percent. If a space runs low on free pages, and the free space percentage falls below 5.5 percent and remains below that level until the `mon_low_storage` task runs next, that task will attempt to expand the space. If the `SP_THRESHOLD` configuration parameter is set to 50000 and a space has fewer than 50000 free kilobytes, that space will be expanded the next time `mon_low_storage` task runs.

A value of 0 turns off the `mon_low_storage` task, and prevents the server from extending any space. However, a value of 0 does not affect the ability of the server to extend a space when all free pages are depleted and more are needed.

The value specified in the `SP_THRESHOLD` configuration parameter applies to all spaces belonging to the server.

Related reference:

“`onmode -wf, -wm`: Dynamically change certain configuration parameters” on page 15-26

SP_WAITTIME configuration parameter

Use the `SP_WAITTIME` configuration parameter to specify the maximum number of seconds that a thread waits for a dbspace, temporary dbspace, sbspace, temporary sbspace, or blobspace space to expand before returning an out-of-space error.

`onconfig.std` *value*
30

units seconds

default value
30

range of values
0 to 2147483647

takes effect

After you edit your `onconfig` file and restart the database server.

When you reset the value dynamically in your `onconfig` file by running the **`onmode -wf`** command.

When you reset the value for a session by running the **`onmode -wm`** command.

Usage

The time that the server uses to automatically add or expand a chunk can vary widely, depending on various factors such as the size of the chunk, the speed of the associated disk drives, and the load on the system. When Informix automatically adds or expands a chunk to prevent free space from falling below the threshold specified by the `SP_THRESHOLD` configuration parameter, Informix forces threads that need the space to wait until it is available. You can change the value of the `SP_WAITTIME` configuration parameter if you want to change the maximum amount of time that the thread will wait for more space.

A thread will wait for a storage space to expand only if the storage pool contains entries. A thread will not wait if the storage pool is empty.

Related reference:

“`onmode -wf, -wm`: Dynamically change certain configuration parameters” on page 15-26

SQL_LOGICAL_CHAR configuration parameter

Use the `SQL_LOGICAL_CHAR` configuration parameter to enable or disable the expansion of size specifications in declarations of built-in character data types.

`onconfig.std` value

OFF (= interpret size specifications in units of bytes)

range of values

OFF, 1, 2, 3, 4, ON,

takes effect

After you edit your `onconfig` file and restart the database server.

When you reset the value dynamically in your `onconfig` file by running the **`onmode -wf`** command.

When you reset the value for a session by running the **`onmode -wm`** command.

refer to

- Information about the **flags** column of the **systables** system catalog table, in the *IBM Informix Guide to SQL: Reference*
- Enabling logical character semantics in character data type declarations, in the *IBM Informix Guide to SQL: Syntax*
- Multibyte code sets and logical character support in SQL features, in the *IBM Informix GLS User's Guide*

Usage

For applications that are developed in single-byte locales, but deployed in multibyte locales, this feature can reduce the risk of multibyte logical characters being truncated during data entry operations.

In a multibyte code set, such as **UTF-8** or the multibyte code sets for some East Asian languages, a single logical character can require more than one byte of storage. The setting of this parameter can instruct the SQL parser to apply logical-character semantics to declarations of these built-in character data types:

- CHAR
- CHARACTER
- CHARACTER VARYING
- LVARCHAR
- NCHAR
- NVARCHAR
- VARCHAR
- DISTINCT types that declare any of these data types as their base types
- ROW types (named and unnamed) that include fields of these data types
- Collection types (LIST, MULTISSET, or SET) that include these types as elements.

The setting that you specify for this parameter must be one of the following values:

Value	Effect
OFF	No expansion of declared sizes
1	No expansion of declared sizes
2	Use 2 as the expansion factor for declared sizes.
3	Use 3 as the expansion factor for declared sizes.
4	Use 4 as the expansion factor for declared sizes.
ON	Use <i>M</i> as the expansion factor, where <i>M</i> is the maximum length in bytes that any logical character requires in the code set of the current database. Depending on the DB_LOCALE setting, <i>M</i> has an integer range from 1 (in single-byte locales) up to 4.

Whether the **SQL_LOGICAL_CHAR** configuration parameter is set to enable or disable the expansion of declared storage sizes, its setting specifies how data type declarations are interpreted for all sessions of the Informix instance.

Automatic Resizing of the Expansion Factor

When **SQL_LOGICAL_CHAR** is set to a valid digit, and the current session creates a database, Informix compares the **SQL_LOGICAL_CHAR** value with the maximum number of bytes that any logical character will use for the code set of the database.

If the **SQL_LOGICAL_CHAR** setting is greater than that maximum number of bytes, the database uses the maximum value for the locale as the new expansion factor, overriding what the configuration file specifies. The **SQL_LOGICAL_CHAR** setting in the configuration file remains unchanged, and continues to act as the default expansion factor for other user databases.

Similarly, if the **SQL_LOGICAL_CHAR** value for a session is automatically reset to a digit, as described above, but the same session subsequently connects to another database whose locale uses a code set in which a logical character requires a larger storage size than the current expansion factor, Informix uses the maximum number

of bytes for the new code set as the new expansion factor while the user session is connected to that database, rather than using the current setting of `SQL_LOGICAL_CHAR`.

Automatic resetting of the expansion factor to match the largest logical character size in the code set that `DB_LOCALE` specifies at connection time also occurs when `SQL_LOGICAL_CHAR` is set to `ON`, but the effects of the `ON` setting are not identical to the database server behavior when `SQL_LOGICAL_CHAR` is set to a digit (1, 2, 3, or 4) in two ways:

- The expansion factor can be automatically reset to a smaller value if `ON` is the `SQL_LOGICAL_CHAR` setting.
- There is no difference between `SQL_LOGICAL_CHAR = 4` and `SQL_LOGICAL_CHAR = ON`.

You must set `SQL_LOGICAL_CHAR` to `ON`, rather than to a digit, if you want a smaller expansion factor when the current session connects to a database whose largest logical character in the `DB_LOCALE` code set requires a smaller number of bytes than the current `SQL_LOGICAL_CHAR` setting. The effective expansion factor will always be less than or equal to the maximum character size for a locale.

SQLTRACE Configuration Parameter

Use the `SQLTRACE` parameter to control the startup environment of SQL tracing.

onconfig.std value

```
#SQLTRACE level=low,ntraces=1000,size=2,mode=global
```

values See the Usage section.

takes effect

After you edit your `onconfig` file and restart the database server.

After you run the SQL administration API `task()` or `admin()` function with the `set sql tracing` argument.

Usage

Remove the `#` symbol from the `onconfig` value to retain basic information, up to 2 KB in size, about the last 1000 SQL statements that were run by any user. You can customize the scope of the SQL tracing information by adjusting the field values of the `SQLTRACE` configuration parameter.

Syntax for the SQLTRACE configuration parameter

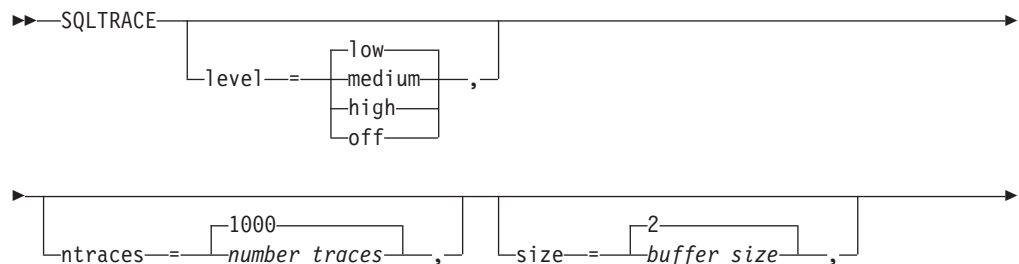



Table 1-62. Options for the SQLTRACE configuration parameter value

Field	Values
level	Amount of information traced: <ul style="list-style-type: none"> • Low = Default. Captures statement statistics, statement text, and statement iterators. • Medium = Captures all of the information included in low-level tracing, plus table names, the database name, and stored procedure stacks. • High = Captures all of the information included in medium-level tracing, plus host variables. • Off = Specifies no SQL tracing.
ntraces	The <i>number_traces</i> value is the number of SQL statements to trace before reusing the resources. Default is 1000. The range is 500 - 2147483647.
size	The <i>buffer_size</i> value is the maximum size of variable length data to be stored, in KB. Default is 2. The range is 1 -100. If this buffer size is exceeded, the database server discards saved data.
mode	Scope of tracing performed: <ul style="list-style-type: none"> • Global = Default. All users. • User = Users who have tracing enabled by an SQL administration API task() or admin() function. Specify this mode if you want to get a sample of the SQL that a small set of users is running.

The **onstat -g his** command displays SQL trace information.

Related tasks:

 Specifying startup SQL tracing information by using the SQLTRACE configuration parameter (Administrator's Guide)

Related reference:

“**onstat -g his** command: Print SQL trace information” on page 21-97

“set sql tracing argument: Set global SQL tracing (SQL administration API)” on page 22-112

SSL_KEYSTORE_LABEL configuration parameter

Use the SSL_KEYSTORE_LABEL configuration parameter to specify the label of the server digital certificate used in the keystore database, a protected database that stores SSL keys and digital certificates.

onconfig.std *value*

None

range of values

Up to 512 characters for the label of the Informix certificate used in Secure Sockets Layer (SSL) protocol communications

takes effect

When the database server is shut down and restarted

refer to Secure Sockets Layer protocol information in the IBM Informix Security Guide

The default value is name of the label for the default SSL certificate that is stored in the Informix keystore in the **INFORMIXDIR/ssl/servername.kdb** directory.

For information on configuration parameters that you need to set on clients, see the IBM Informix Security Guide.

STACKSIZE configuration parameter

Use the STACKSIZE configuration parameter to specify the stack size for the database server user threads.

onconfig.std *value*

32 for 32-bit database servers 64 for 64-bit database servers

units Kilobytes

range of values

32 through limit determined by the database server configuration and the amount of memory available

takes effect

After you edit your onconfig file and restart the database server.

When you reset the value dynamically in your onconfig file by running the **onmode -wf** command.

When you reset the value for a session by running the **onmode -wm** command.

refer to

- Stacks, in the chapter on virtual processors in the *IBM Informix Administrator's Guide*
- CREATE FUNCTION statement, in the *IBM Informix Guide to SQL: Syntax*

Usage

The value of STACKSIZE does not have an upper limit, but setting a value that is too large wastes virtual memory space and can cause swap-space problems.

For 32-bit platforms, the default STACKSIZE value of 32 kilobytes is sufficient for nonrecursive database activity. For 64-bit platforms, the recommended STACKSIZE value is 64 kilobytes. When the database server performs recursive database tasks, as in some SPL routines, for example, it checks for the possibility of stack-size overflow and automatically expands the stack.

User threads execute user-defined routines. To increase the stack size for a particular routine, use the **stack** modifier on the CREATE FUNCTION statement.

Warning: Setting the value of *STACKSIZE* too low can cause stack overflow, the result of which is undefined but usually undesirable.

Related reference:

“onmode -wf, -wm: Dynamically change certain configuration parameters” on page 15-26

[📄](#) INFORMIXSTACKSIZE environment variable (SQL Reference)

STAGEBLOB Configuration Parameter

onconfig.std *value*

None

range of values

Up to 128 bytes. STAGEBLOB must be unique, begin with a letter or underscore, and contain only digits, letters, underscores, or \$ characters.

takes effect

When the database server is shut down and restarted

refer to IBM Informix Optical Subsystem Guide

Use this parameter only if you are storing TEXT or BYTE data on optical storage with the Optical Subsystem. This parameter has no effect on ordinary blobspaces or sbspaces.

STAGEBLOB is the blobspace name for the area where the Optical Subsystem stages TEXT and BYTE data that is destined for storage on optical disk.

STATCHANGE configuration parameter

Use the STATCHANGE configuration parameter to specify a positive integer for a global percentage of a change threshold for the server to use to determine if distribution statistics qualify for an update when the automatic mode for UPDATE STATISTICS operations is enabled.

onconfig.std *value*

10

units percentage of a change threshold

default value

10

range of values

0 through 100

takes effect

After you edit your onconfig file and restart the database server.

When you reset the value dynamically in your onconfig file by running the **onmode -wf** command.

When you reset the value for a session by running the **onmode -wm** command.

Usage

The database server uses the value of the STATCHANGE configuration parameter when the AUTO_STAT_MODE configuration parameter, the AUTO_STAT_MODE session environment variable, or the AUTO keyword of the UPDATE STATISTICS statement has enabled the automatic mode for UPDATE STATISTICS operations.

The STATCHANGE setting specifies a change threshold for the database server to use to determine if distribution statistics qualify for an update when the automatic mode for UPDATE STATISTICS operations is enabled. When this mode is enabled, the UPDATE STATISTICS statement compares the STATCHANGE setting with the percentage of rows that have changed in each table or fragment since the current data distributions were calculated, and selectively updates only the missing or stale distribution statistics for each table or fragment within the scope of the UPDATE STATISTICS statement.

Related concepts:

[➤](#) STATCHANGE Environment Option (SQL Syntax)

Related reference:

“AUTO_STAT_MODE configuration parameter” on page 1-32

[➤](#) Statistics options of the CREATE TABLE statement (SQL Syntax)

STMT_CACHE Configuration Parameter

onconfig.std *value*
0

if not present
0

range of values
0, 1, or 2

takes effect
When the database server is shut down and restarted

utilities
onmode -e

refer to

- “onmode -e: Change usage of the SQL statement cache” on page 15-14
- Using the SQL statement cache, in the *IBM Informix Performance Guide*

STMT_CACHE determines whether the database server uses the SQL statement cache. You can enable the SQL statement cache in one of two modes:

- Always use the SQL statement cache unless a user explicitly specifies not to use it. Set the STMT_CACHE configuration parameter to 2 or **onmode -e ON**.
- Use the SQL statement cache only when a user explicitly specifies to use it. Set the STMT_CACHE configuration parameter to 1 or **onmode -e ENABLE**.

The following table describes the possible values.

Possible Value	Meaning
----------------	---------

- | | |
|---|--|
| 0 | SQL statement cache not used (equivalent to onmode -e OFF). |
| 1 | SQL statement cache enabled, but user sessions do not use the cache. Users use the cache only if they set the environment variable STMT_CACHE to 1 or execute the SQL statement SET STATEMENT CACHE ON. |
| 2 | SQL statement cache turned on. All statements are cached. To turn off statement caching, set the environment variable STMT_CACHE to 0 or execute the SQL statement SET STATEMENT CACHE OFF. |

Related reference:

 [STMT_CACHE environment variable \(SQL Reference\)](#)

STMT_CACHE_HITS Configuration Parameter

onconfig.std *value*

0

if not present

0

units Integer

range of values

Any value greater than or equal to 0

takes effect

When the database server is shut down and restarted

utilities

onmode -W STMT_CACHE_HITS onstat (See “**onstat -g ssc** command: Print SQL statement occurrences” on page 21-174.)

refer to

- “onmode -W: Change settings for the SQL statement cache” on page 15-25
- Improving query performance, in the *IBM Informix Performance Guide*

STMT_CACHE_HITS specifies the number of hits (references) to a statement before it is fully inserted in the SQL statement cache. The following table describes the possible values.

Value	Meaning
-------	---------

0	Fully insert all qualified statements in the SQL statement cache.
---	---

>0	The first time a user issues a unique statement, the database server inserts a <i>key-only</i> entry in the cache that identifies the statement. Subsequent identical statements increment the hit count of the <i>key-only</i> cache entry. When the hit count of the <i>key-only</i> cache entry reaches the specified number of hits, the database server fully inserts the statement in the cache. Set <i>hits</i> to 1 or more to exclude ad hoc queries from entering the cache.
----	--

STMT_CACHE_NOLIMIT Configuration Parameter

onconfig.std *value*

0

if not present

1

range of values

0 or 1

takes effect

When the database server is shut down and restarted

utilities

onmode -W STMT_CACHE_NOLIMIT onstat (See “**onstat -g ssc** command: Print SQL statement occurrences” on page 21-174.)

refer to

- “onmode -W: Change settings for the SQL statement cache” on page 15-25
- Improving query performance, in the *IBM Informix Performance Guide*

STMT_CACHE_NOLIMIT controls whether to insert qualified statements into the SQL statement cache. The following table describes the possible values.

Value Meaning

- | | |
|---|--|
| 0 | Prevents statements from being inserted in the cache. The cache can grow beyond the size limit if most of the statements in the cache are currently in use, because the cache cleaning cannot catch up with the insert rate. If you are concerned about memory usage, turn off STMT_CACHE_NOLIMIT to prevent the database server from allocating a large amount of memory for the cache. |
| 1 | Always insert statements in the SQL statement cache regardless of the cache size. |

STMT_CACHE_NUMPOOL Configuration Parameter

onconfig.std *value*
1

if not present
1

units Positive integer

range of values
1 to 256

takes effect
When the database server is shut down and restarted

refer to Improving query performance, in the *IBM Informix Performance Guide*

STMT_CACHE_NUMPOOL specifies the number of memory pools for the SQL statement cache. To obtain information about these memory pools, use **onstat -g ssc pool**.

Because the database server does not insert not all statements that allocate memory from the memory pools in the cache, the cache size might be smaller than the total size of the memory pools.

STMT_CACHE_SIZE Configuration Parameter

onconfig.std *value*
512

default size of SQL statement cache
512 kilobytes (524288 bytes)

units Kilobytes

range of values
Positive integer

takes effect
When the database server is shut down and restarted

utilities

onstat -g ssc (Maxsize field)

refer to Improving query performance, in the *IBM Informix Performance Guide*

The STMT_CACHE_SIZE configuration parameter specifies the size of the SQL statement caches in kilobytes. The new cache size takes effect the next time a statement is added to a cache.

STOP_APPLY configuration parameter

Use the STOP_APPLY configuration parameter to stop an RS secondary server from applying log files received from the primary server.

Stopping the application of log files allows you to recover quickly from erroneous database modifications by restoring the data from the RS secondary server. You can configure the server to either stop the application of logs immediately, or at a specified point in time. When setting the value of STOP_APPLY you must also set LOG_STAGING_DIR. If STOP_APPLY is configured and LOG_STAGING_DIR is not set to a valid and secure directory, the server cannot be initialized.

onconfig.std *value*

None

if not present

0 (Apply logs)

range of values (first parameter)

0, 1, "YYYY:MM:DD-hh:mm:ss". 0 = Apply logs, 1 = Stop applying logs immediately, "YYYY:MM:DD-hh:mm:ss" = Stop the log apply at a specified time, where:

- YYYY = Year
- MM = Month
- DD = Day
- hh = hour
- mm = minute
- ss = second

takes effect

After you edit your onconfig file and restart the database server.

When you reset the value dynamically in your onconfig file by running the **onmode -wf** command.

When you reset the value for a session by running the **onmode -wm** command.

refer to

- "DELAY_APPLY Configuration Parameter" on page 1-53
- "LOG_STAGING_DIR configuration parameter" on page 1-90
- "UPDATABLE_SECONDARY Configuration Parameter" on page 1-162
- *RS Secondary Server Latency for Disaster Recovery* in the *IBM Informix Administrator's Guide*

Usage

Log files are stored in binary format in a directory specified by the LOG_STAGING_DIR configuration parameter. You must specify a valid and secure location for the log files. See “LOG_STAGING_DIR configuration parameter” on page 1-90. Also see the “DELAY_APPLY Configuration Parameter” on page 1-53

The time value specified for the STOP_APPLY configuration parameter is assumed to be in the same timezone as the RS secondary server.

The **dbexport** utility cannot support write operations on an updatable secondary server unless the STOP_APPLY parameter is set. (Besides STOP_APPLY, the UPDATABLE_SECONDARY and USELASTCOMMITTED configuration parameters must also be set to enable write operations by **dbexport** on a secondary data replication server.)

Related reference:

“onmode -wf, -wm: Dynamically change certain configuration parameters” on page 15-26

“DELAY_APPLY Configuration Parameter” on page 1-53

“LOG_STAGING_DIR configuration parameter” on page 1-90

“onstat -g cluster command: Print high-availability cluster information” on page 21-65

STORAGE_FULL_ALARM Configuration Parameter

onconfig.std *value*
600,3

units *seconds,severity_level*

range of values

seconds = 0 (off) or a positive integer indicating the number of seconds between notifications

severity_level = 0 (no alarms) or 1 through 5

takes effect

When the database server is shut down and restarted

utilities

None

refer to The section on how to monitor storage spaces is in the chapter on managing disk space in the *IBM Informix Administrator's Guide*.

Use the STORAGE_FULL_ALARM configuration parameter to configure the frequency and severity of messages and alarms when storage spaces become full. When a storage space, such as a dbspace, sbspace, blobspace, or tblspace, or a partition becomes full, an alarm is raised and a message is sent to the online message log. You can specify the number of seconds between notifications with the first value of this parameter. You can specify the lowest severity for event alarms to be returned. Setting a specific severity prevents events that have a lower severity from being raised. But events that have the same or greater severity as the severity specified are raised. For more information on alarm levels, see “Event Alarm Parameters” on page C-4. You can prevent alarms when storage spaces become full by setting this parameter to 0.

Regardless of the value of STORAGE_FULL_ALARM, messages are sent to the online message log when storage spaces or partitions become full.

SYSALARMPROGRAM configuration parameter

Use the SYSALARMPROGRAM configuration parameter to specify the full pathname of the **evidence.sh** script. The database server executes **evidence.sh** when a database server failure occurs. You can use the output from the **evidence.sh** script to diagnose the cause of a database server failure.

onconfig.std *value*

On UNIX: **\$INFORMIXDIR/etc/evidence.sh**

On Windows: Not set. (Commented out.) Listed as **\$INFORMIXDIR\etc\evidence.bat**

range of values

Pathname

takes effect

After you edit your onconfig file and restart the database server.

When you reset the value dynamically in your onconfig file by running the **onmode -wf** command.

When you reset the value for a session by running the **onmode -wm** command.

utilities

None

refer to None

Usage

On Windows, you must enable command extensions for **evidence.bat** to successfully complete. You can enable and disable the extensions for the Command Prompt you are working in by issuing the following commands:

- Enable: cmd /x
- Disable: cmd /y

You can also enable and disable command extensions from the Windows XP registry:

Table 1-63. Enabling command extensions from the Windows registry

Attribute	Value
Hive	HKEY_CURRENT_USER
Key	Software\Microsoft\Command Processor
Name	EnableExtensions
Type	REG_DWORD
Values	0 (disable), 1 (enable)

Related reference:

“onmode -wf, -wm: Dynamically change certain configuration parameters” on page 15-26

SYSSBSPACENAME configuration parameter

Use the SYSSBSPACENAME configuration parameter to specify the name of the sbspace in which the database server stores fragment-level data-distribution statistics, which the **syfragsdist** system catalog table stores as BLOB objects in its **encsdist** column. Also use SYSSBSPACENAME to specify the name of the sbspace in which the database server stores statistics that the UPDATE STATISTICS statement collects for certain user-defined data types.

onconfig.std *value*

None

if not present

0

range of values

Up to 128 bytes. SYSSBSPACENAME must be unique, begin with a letter or underscore, and contain only digits, letters, underscores, or \$ characters.

utilities

onspaces

takes effect

After you edit your onconfig file and restart the database server.

When you reset the value dynamically in your onconfig file by running the **onmode -wf** command.

When you reset the value for a session by running the **onmode -wm** command.

refer to

- “onspaces -c -S: Create an sbspace” on page 20-11
- “Sbspace Structure” on page 4-24
- Updating statistics, in the chapter on individual query performance in your *IBM Informix Performance Guide*
- Sbspace characteristics, in the chapter on configuration effects on I/O in your *IBM Informix Performance Guide*
- Writing user-defined statistics, in the performance chapter in *IBM Informix User-Defined Routines and Data Types Developer’s Guide*
- Providing statistics data for a column, in the *IBM Informix DataBlade API Programmer’s Guide*
- “SBSPACENAME configuration parameter” on page 1-127 (specifies the name of the default sbspace)

Usage

To support fragment level statistics, you must specify the name of an sbspace as the SYSSBSPACENAME setting, and you must allocate that sbspace (by using the **onspaces** utility, as described below. For any table whose STATLEVEL attribute is set to FRAGMENT, the database server returns an error if SYSSBSPACENAME is not set, or if the sbspace to which SYSSBSPACENAME is set was not properly allocated).

SYSSBSPACENAME also specifies the name of the sbspace in which the database server stores statistics that the UPDATE STATISTICS statement collects for certain user-defined data types. Normally, the database server stores statistics in the **sysdistrib** system catalog table.

Do not confuse the SYSSBSPACENAME configuration parameter with the SBSPACENAME configuration parameter .

Because the data distributions for user-defined data types can be large, you have the option to store them in an sbspace instead of in the **sysdistrib** system catalog table. If you store the data distributions in an sbspace, use DataBlade API or Informix ESQL/C functions to examine the statistics.

Even though you specify an sbspace with the SYSSBSPACENAME parameter, you must create the sbspace with the **-c -S** option of the **onspaces** utility before you can use it. The database server validates the name of this sbspace when one of the following occurs:

- The database server attempts to write data distributions of the multirepresentational type to SYSSBSPACENAME when it executes the UPDATE STATISTICS statement with the MEDIUM or HIGH keywords.
- The database server attempts to delete data distributions of the multirepresentational type to SYSSBSPACENAME when it executes the UPDATE STATISTICS statement with the DROP DISTRIBUTIONS keywords.

Although you can store smart large objects in the sbspace specified in SYSSBSPACENAME, keeping the distribution statistics and smart large objects in separate sbspaces is recommended because:

- You avoid disk contention when queries are accessing smart large objects and the optimizer is using the distributions to determine a query plan.
- Disk space takes longer to fill up when each sbspace is used for a different purpose.

Related reference:

“onmode -wf, -wm: Dynamically change certain configuration parameters” on page 15-26

TBLSPACE_STATS configuration parameter

Use the TBLSPACE_STATS configuration parameter to turn on and off the collection of tblspace statistics.

onconfig.std *value*
1

if not present
1

units Integer

range of values
0 or 1

takes effect

When the database server is shut down and restarted

Use the **onstat -g ppf** command to list tblspace statistics.

To turn off the collection of `tblspace` statistics, set `TBLSPACE_STATS` to 0. When `TBLSPACE_STATS` is set to 0, `onstat -g ppf` displays “partition profiles disabled.” To turn on the collection of `tblspace` statistics, set `TBLSPACE_STATS` to 1.

TBLTBLFIRST configuration parameter

Use the `TBLTBLFIRST` configuration parameter if you want to specify the first extent size of `tblspace` `tblspace` in the root `dbspace`. Set this parameter if you do not want the database server to automatically manage the extent size.

onconfig.std value
0

default value

0 = The database server automatically manages the extent size.

units Kilobytes in multiples of page size

range of values

From the equivalent of 250 pages specified in kilobytes to the size of the first chunk minus the space needed for any system objects.

takes effect

After you edit your `onconfig` file and restart the database server.

When you reset the value dynamically in your `onconfig` file by running the `onmode -wf` command.

When you reset the value for a session by running the `onmode -wm` command.

You might want to specify first and next extent sizes to reduce the number of `tblspace` `tblspace` extents and reduce the frequency of situations when you need to place the `tblspace` `tblspace` extents in non-primary chunks. (A primary chunk is the initial chunk in a `dbspace`.)

You can use `oncheck -pt` and `oncheck -pT` to show the first and next extent sizes of a `tblspace` `tblspace`. For more information about the `oncheck` utility, see “`oncheck -pt` and `-pT`: Display `tblspaces` for a Table or Fragment” on page 9-19.

If you want to configure the first extent for a non-root `dbspace`, see information about the `onspaces` utility in Chapter 20, “The `onspaces` utility,” on page 20-1.

Related tasks:

 Specifying the first and next extent sizes for the `tblspace` `tblspace` (Administrator's Guide)

Related reference:

“`onmode -wf`, `-wm`: Dynamically change certain configuration parameters” on page 15-26

“`TBLTBLNEXT` configuration parameter”

TBLTBLNEXT configuration parameter

The `TBLTBLNEXT` configuration parameter specifies the next extent size of `tblspace` `tblspace` in the root `dbspace`. Set this parameter if you do not want the database server to automatically manage the extent size.

onconfig.std value
0

default value

0 = The database server automatically manages the extent size.

units Kilobytes

range of values

From equivalent of 4 pages specified in kilobytes to the maximum chunk size minus three pages

takes effect

After you edit your onconfig file and restart the database server.

When you reset the value dynamically in your onconfig file by running the **onmode -wf** command.

When you reset the value for a session by running the **onmode -wm** command.

If there is not enough space for a next extent in the primary chunk, the extent is allocated from another chunk. If the specified space is not available, the closest available space is allocated.

Related tasks:

 Specifying the first and next extent sizes for the tblspace tblspace (Administrator's Guide)

Related reference:

“onmode -wf, -wm: Dynamically change certain configuration parameters” on page 15-26

“TBLTBLFIRST configuration parameter” on page 1-159

TEMPTAB_NOLOG configuration parameter

Use the TEMPTAB_NOLOG configuration parameter to disable logging on temporary tables.

onconfig.std *value*

0

range of values

0 = Enable logical logging on temporary table operations

1 = Disable logical logging on temporary table operations

takes effect

After you edit your onconfig file and restart the database server.

When you reset the value dynamically in your onconfig file by running the **onmode -wf** command.

When you reset the value for a session by running the **onmode -wm** command.

Usage

This parameter can improve performance in application programs because it prevents Informix from transferring temporary tables over the network. The setting can be updated dynamically with the **onmode -wf** utility.

If you enable this setting, be aware that because no data is logged when using temporary tables, rolling back a transaction on a temporary table will no longer undo the work in the temporary table.

For HDR, RSS, and SDS secondary servers in a high-availability cluster, logical logging on temporary tables should always be disabled by setting the `TEMPTAB_NOLOG` configuration parameter to 1.

Related reference:

“`onmode -wf, -wm`: Dynamically change certain configuration parameters” on page 15-26

TXTIMEOUT configuration parameter

Use the `TXTIMEOUT` configuration parameter to specify the amount of time that a participant in a two-phase commit waits before it initiates participant recovery.

onconfig.std *value*
300

units Seconds

range of values
Positive integers

takes effect

After you edit your `onconfig` file and restart the database server.

When you reset the value dynamically in your `onconfig` file by running the **`onmode -wf`** command.

When you reset the value for a session by running the **`onmode -wm`** command.

refer to How the two-phase commit protocol handles failures, in the chapter on multiphase commit protocols in the *IBM Informix Administrator's Guide*

This parameter is used only for distributed queries that involve a remote database server. Nondistributed queries do not use this parameter.

Related reference:

“`onmode -wf, -wm`: Dynamically change certain configuration parameters” on page 15-26

UNSECURE_ONSTAT Configuration Parameter

onconfig.std *value*
None

possible values
1 = All users can run **`onstat`** commands to view running SQL statements

takes effect

When the database server is shut down and restarted

refer to *IBM Informix Administrator's Guide*

The `onstat` commands that show the SQL statement text that is executing on a session are by default normally restricted to DBSA users. To remove this restriction, set the `UNSECURE_ONSTAT` configuration parameter to 1. The **`onstat`** commands that show SQL statements include **`onstat -g his`**, **`onstat -g ses`**, **`onstat -g stm`**, **`onstat -g ssc`**, and **`onstat -g sql`**.

UPDATABLE_SECONDARY Configuration Parameter

Use the UPDATABLE_SECONDARY configuration parameter to set the number of connections to establish between the primary and secondary servers. Setting this configuration parameter enables client applications to perform update, insert, and delete operations on a high-availability secondary server.

onconfig.std *value*
0

if not present
0

units Number of network connections between a given secondary server and its primary server

range of values
Any number from zero (the default value) up to twice the number of CPU VPs. Setting the value to 0 configures the secondary server as read-only. Setting the value from 1 through twice the number of CPU VPs makes the secondary server updatable and configures connection threads.

takes effect
When the secondary database server is shut down and restarted

refer to

- Data Replication Overview chapter of the *IBM Informix Administrator's Guide*
- Server Multiplexer Group (SMX) Connections chapter of the *IBM Informix Administrator's Guide*

Isolation Levels for Secondary Data Replication Servers

If the UPDATABLE_SECONDARY configuration parameter is not set or is set to zero (0), a secondary data replication server is read-only. In this case, only the DIRTY READ or READ UNCOMMITTED transaction isolation levels are available on secondary servers.

If the UPDATABLE_SECONDARY parameter is set to a valid number of connections greater than zero (0), a secondary data replication server can support the COMMITTED READ, COMMITTED READ LAST COMMITTED, or COMMITTED READ transaction isolation level, or the USELASTCOMMITTED session environment variable. Only SQL DML statements, such as INSERT, UPDATE, MERGE, and DELETE, and the **dbexport** utility, can support write operations on an updatable secondary server. (Besides UPDATABLE_SECONDARY, the STOP_APPLY and USELASTCOMMITTED configuration parameters must also be set to enable write operations by **dbexport** on a secondary data replication server.)

Related reference:

"**onstat -g cluster** command: Print high-availability cluster information" on page 21-65

USELASTCOMMITTED configuration parameter

Use the USELASTCOMMITTED configuration parameter to specify the isolation level for which the LAST COMMITTED feature of the COMMITTED READ isolation level is implicitly in effect.

The LAST COMMITTED feature can reduce the risk of locking conflicts between concurrent transactions on tables that have exclusive row locks. The USELASTCOMMITTED configuration parameter can also enable LAST COMMITTED semantics for READ COMMITTED and READ UNCOMMITTED isolation levels of the SET TRANSACTION statement.

The USELASTCOMMITTED configuration parameter only works with tables that have been created or altered to have ROW as their locking granularity. Tables created without any explicit lock mode setting will use the default setting in DEF_TABLE_LOCKMODE. If DEF_TABLE_LOCKMODE is set to PAGE, the USELASTCOMMITTED configuration parameter cannot enable access to the most recently committed data in tables on which uncommitted transactions hold exclusive locks, unless the tables were explicitly altered to have ROW level of locking granularity. For more details, please refer to “DEF_TABLE_LOCKMODE configuration parameter” on page 1-51.

onconfig.std *value*

None

range of values

None = No isolation level identified. If your session encounters an exclusive lock when attempting to read a row in the Committed Read, Dirty Read, Read Committed, or Read Uncommitted isolation level, your transaction cannot read that row until the concurrent transaction that holds the exclusive lock is committed or rolled back.

'Committed Read'

= All transactions from a Committed Read isolation level are treated as last committed transactions. The database server reads the most recently committed version of the data when it encounters an exclusive lock while attempting to read a row in the Committed Read or Read Committed isolation level.

'Dirty Read'

= All transactions from a Dirty Read isolation level are treated as last committed transactions. The database server reads the most recently committed version of the data if it encounters an exclusive lock while attempting to read a row in the Dirty Read or Read Uncommitted isolation level.

All

= All transactions from both Committed Read and Dirty Read isolation levels are treated as last committed transactions. database server reads the most recently committed version of the data if it encounters an exclusive lock while attempting to read a row in the Committed Read, Dirty Read, Read Committed, or Read Uncommitted isolation level.

takes effect

After you edit your onconfig file and restart the database server.

When you reset the value dynamically in your onconfig file by running the **onmode -wf** command.

When you reset the value for a session by running the **onmode -wm** command.

refer to

- SET ISOLATION statement information in *IBM Informix Guide to SQL: Syntax*

- Isolation level information in *IBM Informix Performance Guide*

Use with Shared Disk Secondary Database Servers

The USELASTCOMMITTED configuration parameter is also valid on SD (Shared Disk) secondary database servers. The following table shows valid values for the USELASTCOMMITTED configuration parameter on SD secondary servers and their descriptions.

Table 1-64. Valid Secondary Server USELASTCOMMITTED Values

USELASTCOMMITTED value	Description
None	COMMITTED READ LAST COMMITTED is not the default isolation level for sessions
Committed Read	COMMITTED READ LAST COMMITTED is the default isolation level for all sessions with Committed Read isolation
Dirty Read	COMMITTED READ LAST COMMITTED is the default isolation level for all sessions with Dirty Read isolation
All	COMMITTED READ LAST COMMITTED is the default isolation level for all sessions with Committed Read or Dirty Read isolation

Related concepts:

 USELASTCOMMITTED Environment Option (SQL Syntax)

Related reference:

“onmode -wf, -wm: Dynamically change certain configuration parameters” on page 15-26

USEOSTIME Configuration Parameter

onconfig.std value
0

range of values
0 = Off 1 = On

takes effect
During initialization

refer to

- Your *IBM Informix Performance Guide*
- Using the CURRENT function to return a datetime value, in the *IBM Informix Guide to SQL: Syntax*

Setting USEOSTIME to 1 specifies that the database server is to use subsecond precision when it obtains the current time from the operating system for SQL statements. The following example shows subseconds in a datetime value:

```
2001-09-29 12:50:04.612
```

If subsecond precision is not needed, the database server retrieves the current time from the operating system once per second, making the precision of time for client applications one second. If you set USEOSTIME to 0, the current function returns a zero (.000) for the year to fraction field.

When the host computer for the database server has a clock with subsecond precision, applications that depend on subsecond accuracy for their SQL statements should set USEOSTIME to 1.

Systems that run with USEOSTIME set to nonzero notice a performance degradation of up to 4 to 5 percent compared to running with USEOSTIME turned off.

This setting does not affect any calls regarding the time from application programs to Informix embedded-language library functions.

USERMAPPING configuration parameter (UNIX, Linux)

Use the USERMAPPING configuration parameter to set whether or not the database server accepts connections from mapped users.

default value

OFF

range of values

OFF = Only users that are registered in the Informix host computer OS with a login service can connect to the database server. Externally authenticated users without OS accounts on the Informix host computer cannot connect to database server resources.

BASIC = Users can connect to Informix without an OS account. A user without an OS account cannot perform privileged user operations on the database server, even if the user maps to a server administrator user or group ID.

ADMIN = Users can connect to Informix without an OS account. If a user has authenticated with the identity of a privileged user and is mapped to the proper server administrator group ID, the user can perform DBSA, DBSSO, or AAO work on the database server.

takes effect

After you edit your onconfig file and restart the database server.

When you reset the value dynamically in your onconfig file by running the **onmode -wf** command.

When you reset the value for a session by running the **onmode -wm** command.

Usage

Externally authenticated users without operating system (OS) accounts on the Informix host computer can access database server resources when USERMAPPING is turned on by setting the parameter with the BASIC or ADMIN value. The setting of BASIC or ADMIN also determines whether or not mapped users can be granted administrative privileges.

Important: Changing the USERMAPPING configuration parameter from OFF to ADMIN or BASIC is not the only step in setting up Informix for mapped users. To map users with the appropriate user properties, you must also use DDL statements such as CREATE USER and ALTER USER to register values in appropriate system tables of the SYSUSER database. Depending on the DDL statement used and the defined table mapping, the following tables will be updated or populated:

- SYSINTAUTHUSERS

- SYSUSERMAP
- SYSSURORGATES
- SYSSURROGATEGROUPS

USTLOW_SAMPLE configuration parameter

Use the USTLOW_SAMPLE configuration parameter to enable the generation of index statistics based on sampling when you run UPDATE STATISTICS statements in LOW mode.

onconfig.std *value*
0

default value
0

range of values
0 = disable sampling
1 = enable sampling

utility commands
onmode -wm or **onmode -wf**

takes effect
When the database server is stopped and restarted or when the USTLOW_SAMPLE value is changed by an **onmode -wm** or **onmode -wf** command.

For an index with more than 100 K leaf pages, the gathering of statistics using sampling can increase the speed of the UPDATE STATISTICS operation.

Related concepts:

 USTLOW_SAMPLE environment option (SQL Syntax)

 Data sampling during update statistics operations (Performance Guide)

Related reference:

“onmode -wf, -wm: Dynamically change certain configuration parameters” on page 15-26

VP_MEMORY_CACHE_KB configuration parameter

Use the VP_MEMORY_CACHE_KB parameter to enable the database server to access the private memory blocks of your CPU VP.

onconfig.std *value*
0

range of values
0 = Off 800 kilobytes per VP to the total kilobytes of the private caches in all VPs, not to exceed 40 percent of the memory limit as specified in the SHMTOTAL configuration parameter

takes effect

After you edit your onconfig file and restart the database server.

When you reset the value dynamically in your onconfig file by running the **onmode -wf** command.

When you reset the value for a session by running the **onmode -wm** command.

refer to the CPU Virtual Processor Memory Caches section of the *IBM Informix Performance Guide*

Informix uses the VP private memory cache when a thread needs to allocate whole memory blocks. Informix does not use the private memory cache for buffers in the buffer pool or for any pages read from disk. For example, if you set the `VP_MEMORY_CACHE_KB` configuration parameter to 1000, the sum of all memory blocks in the cache will be no greater than 1000 kilobytes in size.

If you set the **onmode -wf** or **-wm** options to 0, the memory caches are emptied.

The **onstat -g vpcache** option returns information about CPU VP memory block cache statistics.

Related reference:

“onmode -wf, -wm: Dynamically change certain configuration parameters” on page 15-26

“scheduler lmm enable argument: Specify automatic low memory management settings (SQL administration API)” on page 22-102

VPCLASS configuration parameter

Use the VPCLASS configuration parameter to create and configure virtual processors.

onconfig.std values

```
VPCLASS cpu,num=1,noage
```

```
#VPCLASS aio,num=1
```

```
#VPCLASS jvp,num=1
```

values Up to 128 bytes of characters. Each VPCLASS configuration parameter value must be unique, begin with a letter or underscore, and contain only digits, letters, underscores, or \$ characters. Do not include blank spaces.

separators

Separate each field with a comma.

takes effect

After you edit your onconfig file and restart the database server.

Usage

The VPCLASS configuration parameter has three entries in the onconfig.std file, but only the first one is in effect:

- `VPCLASS cpu,num=1,noage`: Creates one CPU virtual processor without aging.
- `#VPCLASS aio,num=1`: Remove the comment symbol to create one AIO virtual processor.
- `#VPCLASS jvp,num=1`: Remove the comment symbol to create one JVP virtual processor.

You can add other VPCLASS configuration parameter entries in your onconfig file. Each VPCLASS configuration parameter must describe a different class of virtual processors. Put each definition on a separate line.

Syntax for the VPCLASS configuration parameter

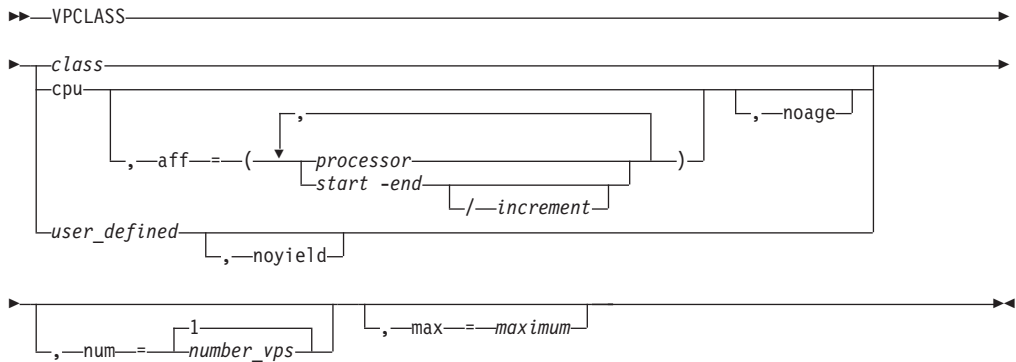

Table 1-65. Options for the VPCLASS configuration parameter value

Field	Values
<i>class</i>	<p>The <i>class</i> value is the name of the virtual processor class. The database server starts most virtual processors as needed. Typically, you might set the VPCLASS configuration parameter for the CPU, AIO, JVP, and user-defined virtual processor classes.</p> <p>The virtual processor class name is not case sensitive.</p>
<i>user_defined</i>	<p>The <i>user_defined</i> value is the name of a virtual processor class that you create for user-defined routines.</p> <p>Make sure the SINGLE_CPU_VP configuration parameter is set to 0.</p>
<i>cpu</i>	Specifies the CPU virtual processor class.
<i>num</i>	<p>The <i>number_vps</i> value sets the number of virtual processors of the specified class that the database server should start when the database server starts. The default value is 1. The range of values for the cpu and aio virtual processor classes is 1- 10000. The range of values for all other virtual processor classes is 0 - 10000.</p> <p>You can use the onmode -p command to add virtual processors for the class for the current session.</p>
<i>max</i>	<p>The <i>maximum</i> value specifies the maximum number of virtual processors that the database server can start for the class. The value can be any integer greater than 0. By default, the number is unlimited.</p>
<i>aff</i>	<p>On multiprocessor computers that support processor affinity, the aff option specifies the CPUs to which the database server binds CPU virtual processors. The operating system numbers the CPUs from 0 to one less than the number of CPUs. By default, CPU virtual processors are assigned to available processors in round-robin fashion. The aff option takes one or more integers:</p> <ul style="list-style-type: none"> • <i>processor</i> = The CPU number to which to bind the CPU virtual processors. The CPU numbers can be listed in any order. • <i>start</i> = The beginning of a range of CPU numbers. • <i>end</i> = The end of a range of CPU numbers. • <i>increment</i> = A factor that specifies which of the CPU numbers in a range are used. For example, aff=(1-5/2) specifies to use CPU numbers 1, 3, and 5.

Table 1-65. Options for the VPCLASS configuration parameter value (continued)

Field	Values
noage	Disables priority aging for CPU virtual processors, if the operating system implements priority aging. By default, priority aging is in effect.
noyield	<p>Specifies that a user-defined virtual processor class does not yield, which allows the C UDR to yield to other threads that need access to the user-defined virtual processor class. By default, threads for user-defined virtual processors yield.</p> <p>A nonyielding user-defined virtual processors class executes a user-defined routine in a way that gives the routine exclusive use of the virtual processor class. User-defined routines that use a noyield virtual-processor class run serially and never yield the virtual processors to another thread.</p> <p>Only specify one virtual processor in a nonyielding user-defined virtual processor class, because the UDR runs on a single virtual processor until it completes and any additional virtual processors would be idle.</p>

The options can appear in any order, separated by commas.

Use the **onmode -p** command to dynamically add or remove virtual processors for the current database session. The **onmode -p** command does not update the onconfig file.

CPU virtual processors

On a single-processor computer, allocate only one CPU virtual processor. On a multiprocessor computer, allocate a total number of CPU virtual processes plus user-defined virtual processors up to the number of CPUs on the computer.

When the database server starts, the number of CPU virtual processors is automatically increased to half the number of CPU processors on the database server computer, unless the SINGLE_CPU_VP configuration parameter is enabled. The value of the **num** option of the VPCLASS configuration parameter for the CPU class is not updated when the database server automatically adds CPU virtual processors.

You can configure processor affinity and whether to allow aging. For example, the following entry creates four CPU virtual processors that are bound to CPU numbers 7, 8, 9, and 10, and are not affected by priority aging:

```
VPCLASS CPU,num=4,aff=(7-10),noage
```

If you specify the **cpu** class name, remove the NUMCPUVPS, AFF_SPROC, AFF_NPROCS, and NOAGE configuration parameters if they exist. These configuration parameters are no longer in use.

AIO virtual processors

Use a VPCLASS configuration parameter entry for the AIO virtual processor class to specify an exact number of AIO virtual processors.

When no VPCLASS configuration parameter entry for the AIO virtual processor class is set, the number of AIO virtual processors is determined by the setting of the AUTO_AIOVPS configuration parameter and is limited to 128:

- If AUTO_AIOVPS is set to 1 (on), the number of AIO virtual processors initially started is equal to the number of AIO chunks.
- If AUTO_AIOVPS is set to 0 (off), the number of AIO virtual processors started is equal to the greater of 6 or twice the number of AIO chunks.

If you specify the **aio** class name, remove the NUMAIOVPS configuration parameter if it exists. This configuration parameter is no longer in use.

Java virtual processors

If you use Java user-defined routines or Java applications, create at least one Java virtual processor by adding a VPCLASS configuration parameter entry for the JVP virtual processor class.

Related concepts:

- [Automatic addition of CPU virtual processors \(Performance Guide\)](#)
- [Types of virtual processors \(Administrator's Guide\)](#)
- [CPU virtual processors \(Administrator's Guide\)](#)
- [Java virtual processors \(Administrator's Guide\)](#)
- [AIO virtual processors \(Administrator's Guide\)](#)

Related reference:

“DS_TOTAL_MEMORY configuration parameter” on page 1-64

“NETTYPE Configuration Parameter” on page 1-101

“onmode -p: Add or remove virtual processors” on page 15-20

- [User-defined classes of virtual processors \(Administrator's Guide\)](#)
- “AUTO_AIOVPS Configuration Parameter” on page 1-28

WSTATS configuration parameter

Use the WSTATS configuration parameter to specify whether the **onstat -g wst** command displays wait statistics for threads within the system.

Attention: You should expect a small performance impact due to the cost of gathering statistical information. Enabling the WSTATS configuration parameter for production systems is not recommended.

onconfig.std *value*
0

range of values

0 = Disable wait statistics

1 = Enable wait statistics

takes effect

After you edit your onconfig file and restart the database server.

When you reset the value dynamically in your onconfig file by running the **onmode -wf** command.

When you reset the value for a session by running the **onmode -wm** command.

utilities

onstat -g wst

refer to

- “**onstat -g wst** command: Print wait statistics for threads” on page 21-185

Related reference:

“**onmode -wf, -wm**: Dynamically change certain configuration parameters” on page 15-26

Chapter 2. The sysmaster database

These topics describe the **sysmaster** database and provide reference information for the *system-monitoring interface* (SMI).

These topics include:

- A description of the **sysmaster** database
- Information about how to use SMI tables
- Descriptions of the SMI tables
- A map of the documented SMI tables

For information about the ON-Bar tables, see the *IBM Informix Backup and Restore Guide*.

The sysmaster Database

The database server creates and maintains the **sysmaster** database. It is analogous to the system catalog for databases, which is described in the *IBM Informix Guide to SQL: Reference*. Just as a system catalog for every database managed by the database server keeps track of objects and privileges in the database, a **sysmaster** database for every database server keeps track of information about the database server.

The **sysmaster** database contains the *system-monitoring interface* (SMI) tables. The SMI tables provide information about the state of the database server. You can query these tables to identify processing bottlenecks, determine resource usage, track session or database server activity, and so on. This chapter describes these tables, which are slightly different from ordinary tables.

Warning: The database server relies on information in the **sysmaster** database. Do not change any of the tables in **sysmaster** or any of the data within the tables. Such changes could cause unpredictable and debilitating results.

The database server creates the **sysmaster** database when it initializes disk space. The database server creates the database with unbuffered logging. You cannot drop the database or any of the tables in it, and you cannot turn logging off.

As user **informix** on UNIX or a member of the **Informix-Admin** group on Windows, you can create SPL routines in the **sysmaster** database. (You can also create triggers on tables within **sysmaster**, but the database server never executes those triggers.)

Joins of multiple tables in **sysmaster** might return inconsistent results because the database server does not lock the tables during a join. You can join **sysmaster** tables with tables in other databases. However, to join **sysmaster** tables with tables in a nonlogging database, first make the nonlogging database the current database.

The buildsmi Script

When you bring the database server up for the first time, it runs a script called **buildsmi**, which is in the **etc** directory. This script builds the database and tables

that support SMI. The database server requires approximately 1750 free pages of logical-log space to build the **sysmaster** database.

If you receive an error message that directs you to run the **buildsmi** script, a problem probably occurred while the database server was building the SMI database, tables, and views. When you use **buildsmi**, the existing **sysmaster** database is dropped and then re-created.

This script must be run as user **informix** on UNIX, or as a member of the **Informix-Admin** group on Windows, after ensuring that no connections to the **sysmaster** database are made during the build of the database. For example, if a Scheduler task is running when the **buildsmi** script commences, the script fails when the Scheduler attempts to access any of the **sysmaster** tables.

Errors issued while the **buildsmi** script runs are written (on UNIX) to the file **/tmp/buildsmi.out**, or on Windows to the file **%INFORMIXDIR%\etc\buildsmi_out.%INFORMIXSERVER%**, where **%INFORMIXSERVER%** is the name of the Informix instance.

The bldutil.sh Script

When you initialize the database server for the first time, it runs a script called **bldutil.sh** on UNIX or **bldutil.bat** on Windows. This script builds the **sysutils** database. If it fails, the database server creates an output file in the **tmp** directory. The output file is **bldutil.process_id** on UNIX and **bldutil.out** on Windows. The messages in this output file reflect errors that occurred during the script execution.

The System-Monitoring Interface

This section describes the SMI tables and how you access them to monitor the database server operation.

Understanding the SMI Tables

The SMI (system-monitoring interface) consists of tables and pseudo-tables that the database server maintains automatically. While the SMI tables appear to the user as tables, they are not recorded on disk as normal tables are. Instead, the database server constructs the tables in memory, on demand, based on information in shared memory at that instant. When you query an SMI table, the database server reads information from these shared-memory structures. Because the database server continually updates the data in shared memory, the information that SMI provides lets you examine the current state of your database server.

The SMI tables provide information about the following topics:

- Auditing
- Checkpoints
- Chunk I/O
- Chunks
- Database-logging status
- Dbspaces
- Disk usage
- Environment variables
- Extents
- Locks

- Networks
- SQL statement cache statistics
- SQL statements
- System profiling
- Tables
- User profiling
- Virtual-processor CPU usage

The data in the SMI tables changes dynamically as users access and modify databases that the database server manages.

Accessing SMI tables

Any user can use SQL SELECT statements to query an SMI table, but standard users cannot run statements other than the SELECT statement. Users who attempt to run other statements result in permission errors. The administrator can run SQL statements other than SELECT, but the results of such statements are unpredictable.

Tip: For more predictable results, query the views that are associated with each table instead of querying the tables directly.

If you query the **systabpaghdrs** table directly, you must specify an appropriate value for the **pg_partnum** parameter. The value is **pg_partnum > 1048576**. However, if you query the view that is associated with the **systabpaghdrs** table, you do not have to specify this value for the **pg_partnum** parameter.

Informix includes the **sysadinfo** and **sysaudit** tables. Only the user **informix** on UNIX or members of the **Informix-Admin** group on Windows can query the **sysadinfo** and **sysaudit** tables.

You cannot use the **dbschema** or **dbexport** utilities on any of the tables in the **sysmaster** database. If you do, the database server generates the following error message:

```
Database has pseudo tables - can't build schema
```

SELECT statements

You can use SELECT statements on SMI tables wherever you can use SELECT against ordinary tables.

For example, you can use SELECT statements ordinary tables from DB-Access, in an SPL routine, with Informix ESQL/C, and so on.

Restriction: You cannot meaningfully reference **rowid** when you query SMI tables. SELECT statements that use **rowid** do not return an error, but the results are unpredictable.

All standard SQL syntax, including joins between tables, sorting of output, and so on, works with SMI tables. For example, if you want to join an SMI table with a non-SMI table, name the SMI table with the following standard syntax:

```
sysmaster[@dbservername]:[owner.]tablename
```

Triggers and Event Alarms

Triggers based on changes to SMI tables never run. Although you can define triggers on SMI tables, triggers are activated only when an INSERT, UPDATE, or DELETE statement occurs on a table. The updates to the SMI data occur within the

database server, without the use of SQL, so a trigger on an SMI table is never activated, even though the data returned by a SELECT statement indicates that it should be.

To create an event alarm, query for a particular condition at predefined intervals, and execute an SPL routine if the necessary conditions for the alarm are met.

SPL and SMI Tables

You can access SMI tables from within a SPL routine. When you reference SMI tables, use the same syntax that you use to reference a standard table.

Locking and SMI Tables

The information in the SMI tables changes based on the database server activity. However, the database server does not update the information using SQL statements. When you use SMI tables with an isolation level that locks objects, it prevents other users from accessing the object, but it does not prevent the data from changing. In this sense, all the SMI tables have a permanent Dirty Read isolation level.

The System-Monitoring Interface Tables

The **sysmaster** database contains many tables that you can use to monitor your system.

Tip: For each system-monitoring interface (SMI) table there is a corresponding view with the same name. For the best results, query the views that are associated with tables instead of querying the underlying tables directly.

Many other tables in the **sysmaster** database are part of the system-monitoring interface but are not documented. Their schemas and column content can change from version to version. The **flags_text** table now contains more rows. To view the new rows you must first drop and then recreate the **sysmaster** database.

The database server supports the following SMI tables:

Table	Description	Reference
sysadinfo	Auditing configuration information	"sysadinfo" on page 2-7
sysaudit	Auditing event masks	"sysadinfo" on page 2-7
syscheckpoint	Checkpoint information	"syscheckpoint" on page 2-8
syschkio	Chunk I/O statistics	"syschkio" on page 2-8
syschunks	Chunk information	"syschunks" on page 2-9
syscluster	High-availability cluster information	"syscluster" on page 2-11
syscmsmsla	Connection Manager information	"syscmsmsla" on page 2-13
syscmsmtab	Connection Manager information	"syscmsmtab" on page 2-13
syscompdicts_full	Compression dictionary information	"syscompdicts_full" on page 2-13
sysconfig	Configuration information	"sysconfig" on page 2-15
sysdatabases	Database information	"sysdatabases" on page 2-15

Table	Description	Reference
sysdbslocale	Locale information	"sysdbslocale" on page 2-16
sysdbspaces	DbSPACE information	"sys extents" on page 2-18
sysdri	Data-replication information	"sysdri" on page 2-17
sysdual	Is a single-row table	"sysdual" on page 2-18
sysenv	Online server's startup environment	"sysenv" on page 2-18
sysenvses	Session-level environment variable	"sysenvses" on page 2-18
sys extents	Extent-allocation information	"sys extents" on page 2-18
sys extspaces	External spaces information	"sys extspaces" on page 2-19
sys sha_lagtime	Secondary server lagtime statistics	"sys sha_lagtime Table" on page 2-20
sys sha_type	Information about connected servers	"sys sha_type" on page 2-21
sys sha_workload	Secondary server workload statistics	"sys sha_workload" on page 2-21
sysipl	Index page logging information	"sysipl" on page 2-22
syslocks	Active locks information	"syslocks" on page 2-22
syslogs	Logical-log file information	"syslogs" on page 2-23
syslogfil	System log file information	"syslogfil table" on page 2-24
sysmgminfo	Memory Grant Manager/Parallel Data Query information	"sysmgminfo" on page 2-24
sysnetclienttype	Client type network activity	"sysnetclienttype" on page 2-25
sysnetglobal	Global network information	"sysnetglobal" on page 2-25
sysnetworkio	Network I/O	"sysnetworkio table" on page 2-26
sysonline log	Online log information	"sysonline log" on page 2-26
sysprofile	System-profile information	"sysprofile" on page 2-27
sysproxyagents	information about all the proxy agent threads	"sysproxyagents" on page 2-28
sysproxydistributors	Proxy distributor information	"sysproxydistributors" on page 2-29
sysproxysessions	Information about sessions using redirected-write functionality	"sysproxysessions table" on page 2-29
sysproxytxnops	Information about transactions operations executing via each proxy distributor	"sysproxytxnops table" on page 2-30
sysproxytxns	Information about all of the current transactions executing via each proxy distributor	"sysproxytxns table" on page 2-30
sysptprof	Table information	"sysptprof table" on page 2-31

Table	Description	Reference
sysrepevtreg	Post events to Connection Manager and to the IBM OpenAdmin Tool (OAT) for Informix	"sysrepevtreg table" on page 2-31
sysrepstats	Post events to Connection Manager and to the OAT	"sysrepstats table" on page 2-32
sysrsslog	RS secondary server information	"sysrsslog" on page 2-35
syssscblst	Memory by user	"syssscblst" on page 2-35
sysseprof	Counts of various user actions	"sysseprof" on page 2-36
sysseappinfo	Distributed Relational Database Architecture (DRDA) client-session information.	"sysseappinfo" on page 2-35
sysseessions	Description of each user connected	"sysseessions" on page 2-36
sysstmx	SMX (server multiplexer group) connection information	"sysstmx" on page 2-38
sysstmxses	SMX (server multiplexer group) session information	"sysstmxses" on page 2-38
sysseqexplain	SQL statement information enabled by the SET EXPLAIN statement	"sysseqexplain table" on page 2-38
syssqltrace	SQL statement information	"syssqltrace" on page 2-39
syssqltrace_info	SQL profile trace system information	"syssqltrace_info" on page 2-41
syssqltrace_iter	SQL statement iterators	"syssqltrace_iter" on page 2-41
syssrcrss	RS secondary server statistics	"syssrcrss" on page 2-41
sysrcsds	SD secondary server statistics	"sysrcsds" on page 2-42
systabnames	Database, owner, and table name for the tblspace tblspace	"systabnames" on page 2-42
systabpaghdrs	Page headers	None
systhreads	Wait statistics	"systhreads" on page 2-43
sysstrgrss	RS secondary server statistics	"sysstrgrss" on page 2-43
sysstrgsds	SD secondary server statistics	"sysstrgsds" on page 2-44
sysvpprof	User and system CPU used by each virtual processor	"sysvpprof" on page 2-44

The sysutils Tables

ON-Bar uses the following tables in the **sysutils** database. For more information, see the *IBM Informix Backup and Restore Guide*.

Table Description

bar_action

Lists all backup and restore actions that are attempted against an object, except during a cold restore. Use the information in this table to track backup and restore history.

bar_instance

Writes a record to this table for each successful backup. ON-Bar might later use the information for a restore operation.

bar_object

Describes each backup object. This table provides a list of all storage spaces and logical logs from each database server for which at least one backup attempt was made.

bar_server

Lists the database servers in an installation. This table is used to ensure that backup objects are returned to their proper places during a restore.

sysadinfo

The **sysadinfo** table contains information about the auditing configuration for the database server. For more information, see your *IBM Informix Security Guide*. You must be user **informix** or user **root** on UNIX or a member of the **Informix-Admin** group on Windows to retrieve information from the **sysadinfo** table.

Column	Type	Description
adtmode	integer	Controls the level of auditing.
adterr	integer	Specifies how the database server behaves when it encounters an error while it writes an audit record.
adtsize	integer	Maximum size of an audit file
adtpath	char(256)	Directory where audit files are written
adtfile	integer	Number of the audit file

sysaudit

For each defined audit mask (that is, for each *username*), the **sysaudit** table contains flags that represent the database events that generate audit records. The **success** and **failure** columns represent the bitmasks that compose the audit masks. If a bit is set in both the **success** and **failure** columns, the corresponding event generates an audit record whether or not the event succeeded.

You must be user **informix** or user **root** on UNIX or a member of the **Informix-Admin** group on Windows to retrieve information from the **sysaudit** table.

Use the **onaudit** utility to list or modify an audit mask. For information about **onaudit** and auditing, see your *IBM Informix Security Guide*.

Column	Type	Description
username	char(32)	Name of the mask
succ1	integer	Bitmask of the audit mask for success
succ2	integer	Bitmask of the audit mask for success
succ3	integer	Bitmask of the audit mask for success
succ4	integer	Bitmask of the audit mask for success
succ5	integer	Bitmask of the audit mask for success
fail1	integer	Bitmask of the audit mask for failure

Column	Type	Description
fail2	integer	Bitmask of the audit mask for failure
fail3	integer	Bitmask of the audit mask for failure
fail4	integer	Bitmask of the audit mask for failure
fail5	integer	Bitmask of the audit mask for failure

syschkio

The **syschkio** system-monitoring interface table provides I/O statistics for individual chunks that the database server manages.

Column	Type	Description
chunknum	smallint	Chunk number
reads	integer	Number of physical reads
pagesread	integer	Number of pages read
writes	integer	Number of physical writes
pageswritten	integer	Number of pages written
mreads	integer	Number of physical reads (mirror)
mpagesread	integer	Number of pages read (mirror)
mwrites	integer	Number of physical writes (mirror)
mpageswritten	integer	Number of pages written (mirror)

syscheckpoint

The **syscheckpoint** table provides information and statistics about checkpoints.

Column	Type	Description
interval	integer	Number of checkpoints since the server was started
type	char(12)	Hard or Interval
caller	char(10)	Caller of the checkpoint
clock_time	integer	Time of day the checkpoint occurred
crit_time	float	Time spent waiting for the critical section to be released
flush_time	float	Time spent flushing pages to disk
cp_time	float	Duration from checkpoint pending until checkpoint done
n_dirty_buffs	integer	Number of dirty buffers
plogs_per_sec	integer	Number of physical log pages processed in a second
llogs_per_sec	integer	Number of logical log pages processed in a second
dskflush_per_sec	integer	Number of buffer pool pages flushed in a second
ckpt_logid	integer	Unique id of the logical log at the checkpoint
ckpt_logpos	integer	Position of the logical log at the checkpoint
physused	integer	Number of pages used in the physical log
logused	integer	Number of pages used in the logical log
n_crit_waits	integer	Number of users who had to wait to enter a critical section

Column	Type	Description
tot_crit_wait	float	Duration spent waiting for all users waiting at the checkpoint critical section block
longest_crit_wait	float	Longest critical section wait
block_time	float	Duration of the checkpoint that blocked the system

syschunks

The **syschunks** table contains a description of each of the chunks that the database server manages.

In the **flags** and **mflags** columns, each bit position represents a separate flag. Thus, it might be easier to read values in the **flags** and **mflags** columns if the values are returned using the HEX function.

Column	Type	Description
chknun	smallint	Chunk number
dbsnun	smallint	Dbspace number
nxchknun	smallint	Number of the next chunk in this dbspace
chksize	integer	Number of pages in this chunk (in units of system default page size)
offset	integer	Page offset of the chunk in its device or path
pagesize	integer	Page size (in bytes)
nfree	integer	Number of free pages in the chunk The free space indicated by the nfree column has different meanings depending on the type of space defined. For dbspaces and smart blobspaces, the free space is reported in units of the basic page size; in blobspaces, the free space is reported in units of the blob space page size. <ul style="list-style-type: none"> • For a dbspace, multiply nfree by the basic page size of either 2KB or 4KB. • For a blobspace, multiply nfree by the blobspace page size. • For a smart blobspace, multiply nfree by the smart blob page size (currently the same as the basic page size).
is_offline	integer	1 If the chunk is offline, 0 if not
is_recovering	integer	1 If the chunk is being recovered, 0 if not
is_blobchunk	integer	1 If the chunk is in a blobspace, 0 if not
is_sbchunk	integer	1 If the chunk is a sbspace, 0 if not
is_inconsistent	integer	1 If the chunk is undergoing logical restore, 0 if not
is_extendable	integer	1 If the chunk is extendable, 0 if not

Column	Type	Description		
flags	smallint	Flags	Hexadecimal	Meaning
		16	0x0010	Chunk is a mirrored chunk
		32	0x0020	Chunk is in offline mode
		64	0x0040	Chunk is in online mode
		128	0x0080	Chunk is in recovery mode
		256	0x0100	Chunk has just been mirrored
		512	0x0200	Chunk is part of a blobspace
		1024	0x0400	Chunk is being dropped
		2048	0x0800	Chunk is part of an optical stageblob
		4096	0x1000	Chunk is inconsistent
		8192	0x2000	Chunk is extendable
		16384	0x4000	Chunk was added during roll forward
		32768	0x8000	Chunk has been renamed
		65536	0x10000	Chunk uses big chunk page header
		131072	0x20000	Chunk has a tblspace tblspace extent
262144	0x40000	No checkpoint has completed since this chunk was initialized (primarily for internal use)		
fname	char(256)	Pathname for the file or device of this chunk		
mdsize	integer	Size in pages of the metadata area of a chunk that belongs to a smart blobspace. If the chunk does not belong to a smart blobspace, the columns stores -1.		
mfname	char(256)	Pathname for the file or device of the mirrored chunk, if any		
moffset	integer	Page offset of the mirrored chunk		
mis_offline	integer	1 If mirror is offline, 0 if not		
mis_recovering	integer	1 If mirror is being recovered, 0 if not		
mflags	smallint	Mirrored chunk flags; values and meanings are the same as the flags column.		
udfree	integer	Free space in pages within the user data area of a chunk that belongs to a smart blobspace. If the chunk does not belong to a smart blobspace, the columns stores -1.		
udsize	integer	Size in pages of the user data area of a chunk that belongs to a smart blobspace. If the chunk does not belong to a smart blobspace, the columns stores -1.		

sysckptinfo

The **sysckptinfo** system-monitoring interface table provides historical information about the previous twenty checkpoints.

Column	Type	Description
ckpt_status	int	0x0011 = A checkpoint was blocked because the physical log ran out of resources. 0x0021 = A checkpoint was blocked because the logical log ran out of resources. 0x0041 = A checkpoint was blocked because transactions were too long. 0x1000 = The physical log is too small. 0x2000 = The logical log space is too small. 0x4000 = The physical log is too small for RTO.
plogs_per_S	int	Average rate of physical logging activity.
llogs_per_S	int	Average rate of logical logging activity.
dskF_per_S	int	Average rate of pages flushed to disk.
longest_dskF	int	Longest duration of time to flush the buffer pool to the disk during checkpoint processing.
dirty_pgs_S	int	Average rate of pages being modified.
sug_plog_sz	int	Suggested physical log size.
sug_llog_sz	int	Suggested logical log space size.
ras_plog_sp	int	Rate at which fast recovery can restore the physical log.
ras_llog_sp	int	Rate at which fast recovery can replay the logical log.
boottime	int	Time it takes for the server to boot shared memory and open chunks.
auto-ckpts	int	1 = on, 0 = off.
auto_lru	int	1 = on, 0 = off.
cur_intvl	int	Current checkpoint interval id.
auto_aiovp	int	1 = on, 0 = off.

Related reference:

“`onstat -g ckp` command: Print checkpoint history and configuration recommendations” on page 21-61

syscluster

The **syscluster** system catalog table stores information about servers in a high-availability cluster. The **syscluster** table has the following columns.

Column	Type	Explanation
name	CHAR(128)	The name of the primary server.
role	CHAR(1)	Code to indicate whether the server is a primary server or secondary server.
syncmode	CHAR(8)	The synchronization mode between the primary server and the secondary server: sync or async.
nodetype	CHAR(8)	The type of server: HDR, RSS, or SDS.

Column	Type	Explanation
supports_updates	CHAR(1)	Indicates whether client applications can perform update, insert, and delete operations on the secondary server (as specified by the UPDATABLE_SECONDARY configuration parameter).
server_status	CHAR(32)	Indicates the status of the secondary server.
connection_status	CHAR(32)	Indicates the connection status of the secondary server.
delayed_apply	INTEGER	Indicates whether the secondary server waits for a specified amount of time before applying logs (as specified by the DELAY_APPLY configuration parameter).
stop_apply	CHAR(24)	Indicates whether the secondary server has stopped applying log files received from the primary server (as specified by the STOP_APPLY configuration parameter).
logid_sent	INTEGER	Indicates the log ID of the most recent log page sent by the primary server to the secondary server.
logpage_sent	INTEGER	Indicates the page number of the most recent log page sent by the primary server to the secondary server.
logid_acked	INTEGER	Indicates the log ID of the most recent log page the secondary server acknowledged.
logpage_acked	INTEGER	Indicates the page number of the most recent log page the secondary server acknowledged.
ack_time	DATETIME YEAR TO SECOND	Indicates the date and time of the last acknowledged log.
sdscycle	INTEGER	Indicates the cycle number to which the primary server has advanced. Used internally by IBM support to monitor coordination of the primary server with the secondary server.
sdscycle_acked	INTEGER	Indicates the cycle number that the shared disk secondary server has acknowledged. Used internally by IBM support to monitor coordination of the primary server with the secondary server.

syscsm

The **syscsm** table is a view of the **syscsmstab** and **syscsmsla** tables. It contains Connection Manager service level agreement (SLA) information. The table is updated once every five seconds.

Column	Type	Description
sid	integer	Connection Manager session ID
name	char(128)	Connection Manager name
host	char(256)	Host name
foc	char(128)	Failover configuration (FOC)

Column	Type	Description
flag	integer	Arbitrator flag. A value of 1 indicates that the Connection Manager Arbitrator is active. A value of 0 indicates that the Arbitrator is inactive.
sla_id	integer	Connection Manager service level agreement (SLA) ID
sla_name	char(128)	SLA name
sla_define	char(128)	SLA define
connections	integer	Number of connections made through Connection Manager

syscmsmsla

The **syscmsmsla** table contains Connection Manager service level agreement (SLA) information. The table is updated once every five seconds.

Column	Type	Description
address	int8	CMSLA internal address
sid	integer	Connection Manager session ID
sla_id	integer	Connection Manager service level agreement (SLA) ID
sla_name	char(128)	SLA name
sla_define	char(128)	SLA define
connections	integer	Number of connections made through Connection Manager

syscmsmtab

The **syscmsmtab** table contains Connection Manager information.

Column	Type	Description
address	int8	Connection Manager internal address
sid	integer	Connection Manager session ID
name	char(128)	Connection Manager name
host	char(256)	Host name
foc	char(128)	Failover configuration (FOC)
flag	integer	Arbitrator flag. A value of 1 indicates that the Connection Manager Arbitrator is active. A value of 0 indicates that the Arbitrator is inactive.

syscompdicts_full

The **syscompdicts_full** table and the **syscompdicts** view provide information on all compression dictionaries. The only difference between the table and the view is that, for security purposes, the view does not contain the **dict_dictionary** column.

Only user **informix** can retrieve information from the **syscompdicts_full** table. The **syscompdicts** view is not restricted to user **informix**.

The following table shows the information that the **syscompdicts_full** table and the **syscompdicts** view provide for each compression dictionary.

Table 2-1. Compression Dictionary Information

Column	Type	Description
dict_partnum	integer	Partition number to which the compression dictionary applies
dict_code_version	integer	Version of the code that is creating the compression dictionary 1 is the first version.
dict_dbsnum	integer	Number of the dbspace that the dictionary resides in
dict_create_timestamp	integer	Timestamp that shows when the dictionary was created
dict_create_loguniqid	integer	Unique ID for the logical log that was created when the dictionary was created
dict_create_logpos	integer	Position within the logical log when the dictionary was created
dict_drop_timestamp	integer	Timestamp that shows when the dictionary was dropped.
dict_drop_loguniqid	integer	Unique ID for the logical log that was created when the dictionary was dropped.
dict_drop_logpos	integer	Position within the logical log when the dictionary was dropped.
dict_dictionary	byte	Compression dictionary binary object This column is not included in the syscompdicts view.

Sample syscompdicts information

A row of information in the **syscompdicts** view could displays columns containing this information:

```
dict_partnum      1048939
dict_code_version 1
dict_dbsnum       1
dict_create_time+ 1231357656
dict_create_logun+ 11
dict_create_logpos 1695768
dict_drop_timesta+ 0
dict_drop_loguniq+ 0
dict_drop_logpos  0
```

You can use an UNLOAD statement to unload the compression dictionary to a compression dictionary file, as follows:

```
UNLOAD TO 'compression_dictionary_file'
  SELECT * FROM sysmaster:syscompdicts_full;
```

sysconfig

The **sysconfig** table describes the effective, original, and default values of the configuration parameters. For more information about the ONCONFIG file and the configuration parameters, see Chapter 1, “Database configuration parameters,” on page 1-1.

Column	Type	Description
cf_id	integer	Unique numeric identifier
cf_name	char(128)	Configuration parameter name
cf_flags	integer	Reserved for future use
cf_original	char(256)	Value in the ONCONFIG file at boot time
cf_effective	char(256)	Value currently in use
cf_default	char(256)	Value provided by the database server if no value is specified in the ONCONFIG file

sysdatabases

The **sysdatabases** view describes each database that the database server manages.

Column	Type	Description
name	char(128)	Database name
partnum	integer	The partition number (tblspace identifier) for the systables table for the database
owner	char(32)	User ID of the creator of the database
created	date	Date created
is_logging	integer	1 If logging is active, 0 if not
is_buff_log	integer	1 If buffered logging, 0 if not
is_ansi	integer	1 If ANSI/ISO-compliant, 0 if not
is_nls	integer	1 If GLS-enabled, 0 if not
is_case_insens	integer	1 If case-insensitive for NCHAR and NVARCHAR columns, 0 if not

Column	Type	Description	
flags	smallint	Logging flags (hex values)	
		0	No logging
		1	Unbuffered logging
		2	Buffered logging
		4	ANSI/ISO-compliant database
		8	Read-only database
		10	GLS database
		20	Checking of the logging mode of syscdr database bypassed
		100	Changed status to buffered logging
		200	Changed status to unbuffered logging
		400	Changed status to ANSI/ISO compliant
		800	Database logging turned off
		1000	Long ID support enabled

sysdbslocale

The **sysdbslocale** table lists the locale of each database that the database server manages.

Column	Type	Description
db _s _db _s name	char(128)	Database name
db _s _collate	char(32)	The locale of the database

sysdbspaces

The **sysdbspaces** table contains a description of each of the dbspaces that the database server manages.

In the **flags** column, each bit position represents a separate flag. Thus, it might be easier to read values in the **flags** column if the values are returned using the HEX function.

Column	Type	Description
db _s num	smallint	Db _s pace number
name	char(128)	Db _s pace name
owner	char(32)	User ID of owner of the db _s pace
fchunk	smallint	Number of the first chunk in the db _s pace
nchunks	smallint	Number of chunks in the db _s pace
create_size	decimal	The minimum size of a chunk that can be created for this space using the storage pool.
extend_size	decimal	The minimum size by which a chunk in this storage space can be extended, either manually or automatically.
pagesize	integer	Page size
is_mirrored	integer	1 If db _s pace is mirrored, 0 if not

Column	Type	Description		
is_blobspace	integer	1 If the dbspace is a blobspace, 0 if not		
is_sbspace	integer	1 If the dbspace is a sbspace, 0 if not		
is_temp	integer	1 If the dbspace is a temporary dbspace, 0 if not		
flags	smallint	Flags	Hexadecimal	Meaning
		1	0x0001	Dbspace has no mirror
		2	0x0002	Dbspace uses mirroring
		4	0x0004	Dbspace mirroring is disabled
		8	0x0008	Dbspace is newly mirrored
		16	0x0010	Space is a blobspace
		32	0x0020	Blobspace is on removable media
		64	0x0040	Blobspace is on optical media
		128	0x0080	Blobspace has been dropped.
		256	0x0100	Blobspace is an optical stageblob
		512	0x0200	Space is being recovered
		1024	0x0400	Space has been physically recovered
		2048	0x0800	Space is in logical recovery
32768	0x8000	Space is an sbspace		

sysdri

The **sysdri** table provides information about the High-Availability Data-Replication status of the database server.

Column	Type	Description
type	char(50)	High-Availability Data Replication type Possible values: <ul style="list-style-type: none"> • primary • secondary • standard • not initialized
state	char(50)	State of High-Availability Data Replication Possible values: <ul style="list-style-type: none"> • off • on • connecting • failure • read-only
name	char(128)	The name of the other database server in the High-Availability Data-Replication pair
intvl	integer	The High-Availability Data-Replication interval

Column	Type	Description
timeout	integer	The High-Availability Data-Replication timeout value for this database server
lostfound	char(256)	The pathname to the lost-and-found file

sysdual

The **sysdual** table returns exactly one column and one row.

Column	Type	Description
dummy	char(1)	Dummy columns returning "X"

sysenv

The **sysenv** table displays the startup environment settings of the database server.

Column	Type	Description
env_id	integer	Identifier variable number
env_name	char(128)	Environment variable name
env_value	char(512)	Environment variable value

sysenvses

The **sysenvses** table displays the environment variable at the session level.

Column	Type	Description
envses_sid	integer	Session id
envses_id	integer	Identifier variable number
envses_name	char(128)	Session environment variable name
envses_value	char(512)	Session environment variable value

sysextents

The **sysextents** table provides information about extent allocation.

Column	Type	Description
dbsname	char(128)	Database name
tablename	char(128)	Table name
chunk	integer	Chunk number
offset	integer	Number of pages into the chunk where the extent begins
size	integer	Size of the extent, in pages

sysextspaces

The `sysextspaces` table provides information about external spaces. Indexes for the `id` column and the `name` column allow only unique values.

Column	Type	Description
<code>id</code>	integer	External space ID
<code>name</code>	char(128)	External space name
<code>owner</code>	char(32)	External space owner
<code>flags</code>	integer	External space flags (reserved for future use)
<code>refcnt</code>	integer	External space reference count.
<code>locsize</code>	integer	Size of external space location, in bytes
<code>location</code>	char (256)	Location of external space

sysfeatures

The `sysfeatures` view provides general information about various features of the Informix database server instance. The `sysfeatures` view is created from an internal table named `syslicenseinfo`, which is stored permanently on the disk. When the database server instances are initialized, the table is pre-allocated with a fixed size which allows tracking of 260 weeks of data. The data wraps every five years.

Metrics are sampled every 15 minutes and only the highest values during the particular week are stored. Each row in the table contains data only for the specific week it represents.

Column	Type	Description
<code>week</code>	smallint	The week that the information was recorded.
<code>year</code>	smallint	The year that the information was recorded.
<code>version</code>	char(12)	The Informix server version.
<code>max_cpu_vps</code>	smallint	The maximum number of CPU virtual processors.
<code>max_vps</code>	smallint	The maximum number of virtual processors.
<code>max_conns</code>	integer	The maximum number of concurrent physical connections on a standalone or high-availability cluster primary server instance.
<code>max_sec_conns</code>	integer	The maximum number of concurrent physical connections on an HDR secondary or RS secondary server instance.
<code>max_sds_clones</code>	smallint	The maximum number of SD secondary server instances connected to the primary server.
<code>max_rss_clones</code>	smallint	The maximum number of RS secondary server instances connected to the primary server.
<code>total_size</code>	integer	The maximum disk space allocated in all chunks (in megabytes).
<code>total_size_used</code>	integer	The maximum disk space used in all chunks (in megabytes).
<code>max_memory</code>	integer	The maximum memory allocated in all segments (in megabytes).

Column	Type	Description
max_memory_used	integer	The maximum memory used in all segments (in megabytes).
is_primary	integer	Indicates whether the server was a primary server in a particular week; 1 = yes, 0 = no.
is_secondary	integer	Indicates whether the server was an HDR secondary server in a particular week; 1 = yes, 0 = no.
is_sds	integer	Indicates whether the server was an SD secondary server in a particular week; 1 = yes, 0 = no (not implemented; always 0).
is_rss	integer	Indicates whether the server was an RS secondary server in a particular week; 1 = yes, 0 = no.
is_er	integer	Indicates whether the server was an enterprise replication server in a particular week; 1 = yes, 0 = no.
is_pdq	integer	Indicates whether the PDQ feature was used on the server instance in the particular week; 1 = yes, 0 = no.

sysha_lagtime Table

The **sysha_lagtime** table provides a history of the amount of time that it took to apply a log record on any of the secondary nodes.

The **sysha_lagtime** table contains a history of the last 20 samplings performed for a particular secondary server.

Column	Type	Description
lt_secondary	CHAR(128)	Name of secondary server
lt_time_last_update	INTEGER	Time at which log record was last updated
lt_lagtime_1	FLOAT	Amount of time required to apply log record for the most recent five-second interval
lt_lagtime_2	FLOAT	Amount of time required to apply log record for the second most recent five-second interval
lt_lagtime_3	FLOAT	Amount of time required to apply log record for the third most recent five-second interval
lt_lagtime_4	FLOAT	Amount of time required to apply log record for the fourth most recent five-second interval
lt_lagtime_5	FLOAT	Amount of time required to apply log record for the fifth most recent five-second interval
lt_lagtime_6	FLOAT	Amount of time required to apply log record for the sixth most recent five-second interval
lt_lagtime_7	FLOAT	Amount of time required to apply log record for the seventh most recent five-second interval
lt_lagtime_8	FLOAT	Amount of time required to apply log record for the eighth most recent five-second interval
lt_lagtime_9	FLOAT	Amount of time required to apply log record for the ninth most recent five-second interval
lt_lagtime_10	FLOAT	Amount of time required to apply log record for the tenth most recent five-second interval
lt_lagtime_11	FLOAT	Amount of time required to apply log record for the eleventh most recent five-second interval

Column	Type	Description
lt_lagtime_12	FLOAT	Amount of time required to apply log record for the twelfth most recent five-second interval
lt_lagtime_13	FLOAT	Amount of time required to apply log record for the thirteenth most recent five-second interval
lt_lagtime_14	FLOAT	Amount of time required to apply log record for the fourteenth most recent five-second interval
lt_lagtime_15	FLOAT	Amount of time required to apply log record for the fifteenth most recent five-second interval
lt_lagtime_16	FLOAT	Amount of time required to apply log record for the sixteenth most recent five-second interval
lt_lagtime_17	FLOAT	Amount of time required to apply log record for the seventeenth most recent five-second interval
lt_lagtime_18	FLOAT	Amount of time required to apply log record for the eighteenth most recent five-second interval
lt_lagtime_19	FLOAT	Amount of time required to apply log record for the nineteenth most recent five-second interval
lt_lagtime_20	FLOAT	Amount of time required to apply log record for the twentieth most recent five-second interval

syssha_type

The **syssha_type** table is a single row table that is used to describe the type of server that is connected.

Column	Type	Description
ha_type	integer	Server type (see table below)
ha_primary	char(128)	Server name (see table below)

Table 2-2. Descriptions for the values in the **syssha_type** table

Value of <i>ha_type</i>	Value of <i>ha_primary</i>	Description
0	NULL	Not part of a high-availability environment
1	<primary server name>	Primary server
2	<primary server name>	HDR secondary server
3	<primary server name>	SD secondary server
4	<primary server name>	RS secondary server

syssha_workload

The **syssha_workload** table contains workload statistics on each of the secondary servers.

Column	Type	Description
wl_secondary	char(128)	Name of secondary server
wl_time_last_update	integer	Time at which workload last updated

Column	Type	Description
wl_type	char(12)	This row contains the ready queue size, user CPU time, and system CPU time
wl_workload_1	float	Most recent workload activity
wl_workload_2	float	Second most recent workload activity
wl_workload_3	float	Third most recent workload activity
wl_workload_4	float	Fourth most recent workload activity
wl_workload_5	float	Fifth most recent workload activity
wl_workload_6	float	Sixth most recent workload activity
wl_workload_7	float	Seventh most recent workload activity
wl_workload_8	float	Eighth most recent workload activity
wl_workload_9	float	Ninth most recent workload activity
wl_workload_10	float	Tenth most recent workload activity
wl_workload_11	float	Eleventh most recent workload activity
wl_workload_12	float	Twelfth most recent workload activity
wl_workload_13	float	Thirteenth most recent workload activity
wl_workload_14	float	Fourteenth most recent workload activity
wl_workload_15	float	Fifteenth most recent workload activity
wl_workload_16	float	Sixteenth most recent workload activity
wl_workload_17	float	Seventeenth most recent workload activity
wl_workload_18	float	Eighteenth most recent workload activity
wl_workload_19	float	Nineteenth most recent workload activity
wl_workload_20	float	Twentieth most recent workload activity

sysipl

The **sysipl** table provides information about the status of index page logging at the primary server.

Column	Type	Description
ipl_status	integer	Index page logging status
ipl_time	integer	Time at which index page logging was enabled

syslocks

The **syslocks** table provides information about all the currently active locks in the database server.

Column	Type	Description
dbname	char(128)	Database name
tablename	char(128)	Table name
rowidlk	integer	Real rowid, if it is an index key lock
keynum	smallint	Key number of index key lock

Column	Type	Description	
type	char(4)	Type of lock	
		B	Byte lock
		IS	Intent shared lock
		S	Shared lock
		XS	Shared key value held by a repeatable reader
		U	Update lock
		IX	Intent exclusive lock
		SIX	Shared intent exclusive lock
		X	Exclusive lock
		XR	Exclusive key value held by a repeatable reader
owner	integer	Session ID of the lock owner	
waiter	integer	Session ID of the user waiting for the lock. If more than one user is waiting, only the first session ID appears.	

syslogs

The **syslogs** table provides information about space use in logical-log files. In the **flags** column, each bit position represents a separate flag. For example, for a log file, the **flags** column can have flags set for both current log file and temporary log file. Thus, it might be easier to read values in the **flags** column if the values are returned using the HEX function.

Column	Type	Description		
number	smallint	Logical-log file number		
uniqid	integer	Log-file ID		
size	integer	Number of pages in the log file		
used	integer	Number of pages used in the log file		
is_used	integer	1 If file is used, 0 if not		
is_current	integer	1 If file is the current file, 0 if not		
is_backed_up	integer	1 If file has been backed up, 0 if not		
is_new	integer	1 If the log has been added since the last level-0 dbspace backup, 0 if not		
is_archived	integer	1 If file has been placed on the backup tape, 0 if not		
is_temp	integer	1 If the file is flagged as a temporary log file, 0 if not		
flags	smallint	Flags		
		Hexadecimal		
		Meaning		
		1	0x01	Log file is in use
		2	0x02	File is current log file
		4	0x04	Log file has been backed up
		8	0x08	File is newly added log file
16	0x10	Log file has been written to dbspace backup media		
32	0x20	Log is a temporary log file		

syslogfil table

The syslogfil table provides information about the logical log files.

Table 2-3. Information about the columns in the syslogfil table.

Column	Type	Description
address	int8	Memory address of the logfile structure
number	small integer	Log file number
flags	integer	For a description of the values and their meanings, see the Flag values section below.
fillstamp	integer	Internal timestamp when the log file was filled
filltime	integer	UNIX time when the log file was filled
uniqid	integer	Unique ID for the log file
chunk	integer	Number of the chunk that contains the log file
offset	integer	Page offset in the chunk where log file begins
size	integer	Total number of pages in the log file
used	integer	Number of pages used in the log file

Flag values

The flag values correspond to many of the flag values for the **onstat -l** command.

Hexadecimal	Onstat -l flag value	Meaning
0x1	U	Log file is in use
0x2	C	File is current log file
0x4	B	Log file has been backed up
0x8	A	File is a newly added log file
0x20	None	A temporary log file
0x40	D	Log file will be dropped after the file is archived
0x4000	L	Log file contains the last checkpoint written

sysmgminfo

The **sysmgminfo** table provides an overview of the Memory Grant Manager (MGM) and Parallel Data Query (PDQ) information.

Column	Type	Description
max_query	integer	Maximum number of active queries allowed
total_mem	integer	Total MGM memory
avail_mem	integer	Free MGM memory
total_seq	integer	Total number of sequential scans
avail_seq	integer	Unused sequential scans
active	integer	Number of active MGM queries
ready	integer	Number of ready MGM queries

Column	Type	Description
min_free_mem	integer	Minimum free MGM memory
avg_free_mem	float	Average free MGM memory
std_free_mem	float	Standard free MGM memory
min_free_seq	integer	Minimum free MGM sequential scans
avg_free_seq	float	Average free MGM sequential scans
std_free seq	float	Standard free MGM sequential scans
max_active	integer	Maximum active MGM SQL operations
cnt_active	integer	Number of active MGM SQL operations
avg_active	float	Average active MGM SQL operations
std_active	float	Standard active MGM SQL operations
max_ready	integer	Maximum ready MGM SQL operations
cnt_ready	integer	Number of ready MGM SQL operations
avg_ready	float	Average ready MGM SQL operations
std_ready	float	Standard ready MGM SQL operations

sysnetclienttype

The **sysnetclienttype** table provides an overview of the network activity for each client type.

Column	Type	Description
nc_cons_allowed	integer	Whether or not connections are allowed
nc_accepted	integer	Number of connections that were accepted
nc_rejected	integer	Number of network connections that were rejected
nc_reads	int8	Number of network reads for this client type
nc_writes	int8	Number of network writes for this client type
nc_name	char(18)	Name of the client type

sysnetglobal

The **sysnetglobal** table provides an overview of the system network.

Column	Type	Description
ng_reads	int8	Number of network reads
ng_writes	int8	Number of network writes
ng_connects	int8	Number of network connections
ng_his_read_count	int8	Number of network reads by users who have disconnected ng_his_read_bytes
ng_his_read_bytes	int8	Data transferred to the server by users who have disconnected
ng_his_write_count	int8	Number of network writes by users who have disconnected
ng_his_write_bytes	int8	Data transferred to the client by users who have disconnected

Column	Type	Description
ng_num_netscbs	integer	Number of network subscribers
ng_max_netscbs	integer	Maximum number of network subscribers
ng_free_thres	integer	Threshold for the maximum number of freed buffers in the buffer list
ng_free_cnt	integer	Number of times the ng_free_thres limit has been reached
ng_wait_thres	integer	Threshold for the maximum number of buffers that can be held in the buffer list for one connection
ng_wait_cnt	integer	Number of times the ng_wait_thres limit has been reached
ng_pvt_thres	integer	Threshold for the maximum number of freed buffers in the private buffer queue
ng_netbuf_size	integer	Size of the transport network buffers
ng_buf_alloc	integer	Number of network buffers allocated
ng_buf_alloc_max	integer	Maximum value of allocated network buffers
ng_netscb_id	integer	Next netscb id

sysnetworkio table

The **sysnetworkio** table contains information about the system network.

Column	Type	Description
net_id	integer	Netscb id
sid	integer	Session id
net_netscb	int8	Netscb prt
net_client_type	integer	Client type Int
net_client_name	char(12)	Client protocol name
net_read_cnt	int8	Number of network reads
net_write_cnt	int8	Number of network writes
net_open_time	integer	Time this session connected
net_last_read	integer	Time of the last read from the network
net_last_write	integer	Time of the last write from the network
net_stage	integer	Connect / Disconnect / Receive
net_options	integer	Options from sqlhosts
net_protocol	integer	Protocol
net_type	char(10)	Type of network protocol
net_server_fd	integer	Server fd
net_poll_thread	integer	Poll thread

sysonlinelog

The **sysonlinelog** table provides a view of the information stored in the online.log file.

Column	Type	Description
offset	int8	File offset
next_offset	int8	Offset to the next message
line	char(4096)	Single line of text from the file

sysprofile

The **sysprofile** table contains profile information about the database server.

Column	Type	Description
name	char(13)	Name of profiled event. (See table that follows for a list of possible events.)
value	integer	Value of profiled event. (See table that follows for a list of possible events.)

The following table lists the events that, together with a corresponding value, make up the rows of the **sysprofile** table.

Events Profiled in sysprofile	Description
dskreads	Number of actual reads from disk
bufreads	Number of reads from shared memory
dskwrites	Actual number of writes to disk
bufwrites	Number of writes to shared memory
isamtot	Total number of calls
isopens	isopen calls
isstarts	isstart calls
isreads	isread calls
iswrites	iswrite calls
isrewrites	isrewrite calls
isdeletes	isdelete calls
iscommits	iscommit calls
isrollbacks	isrollback calls
ovlock	Overflow lock table
ovuser	Overflow user table
ovtrans	Overflow transaction table
latchwts	Latch request waits
bufwts	Buffer waits
lockreqs	Lock requests
lockwts	Lock waits
ckptwts	Checkpoint waits
deadlks	Deadlocks
lktouts	Deadlock time-outs
numckpts	Number checkpoints

Events Profiled in sysprofile	Description
plgpagewrites	Physical-log pages written
plgwrites	Physical-log writes
llgreccs	Logical-log records
llgpagewrites	Logical-log writes
llgwrites	Logical-log pages written
pagereads	Page reads
pagewrites	Page writes
flushes	Buffer-pool flushes
compress	Page compresses
fgwrites	Foreground writes
lruwrites	Least-recently used (LRU) writes
chunkwrites	Writes during a checkpoint
btradata	Read-ahead data pages read through index leaf node
btraidx	Read-ahead data pages read through index branch or root node
dpra	Data pages read into memory with read-ahead feature
rapgs_used	Read-ahead data pages that user used
seqscans	Sequential scans
totalsorts	Total sorts
memsorts	Sorts that fit in memory
disksorts	Sorts that did not fit in memory
maxsortspace	Maximum disk space used by a sort

sysproxyagents

The **sysproxyagents** table contains information about all proxy agent threads. Proxy agent threads run on the primary server and accept requests from secondary servers to process DML operations. The primary server also contains a proxy distributor that handles secondary server updates. Secondary servers determine how many instances of the proxy distributor to create based on the `UPDATABLE_SECONDARY` setting in the secondary server's `ONCONFIG` file.

Column	Type	Description
tid	integer	Transaction ID of the proxy agent thread running on the primary server. This ID is created by the proxy distributor to handle work from the secondary server session.
flags	integer	Flags of the proxy agent thread.
proxy_id	integer	ID of the proxy distributor on behalf of the currently executing proxy agent thread (TID).
source_session_id	integer	ID of the user's session on the secondary server.
proxy_txn_id	integer	Number of the current transaction. These numbers are unique to the proxy distributor.
current_seq	integer	The sequence number of the current operation in the current transaction.

Column	Type	Description
sqlerrno	integer	Error number of any SQL error (or 0 on success)
iserrno	integer	Error number of any ISAM/RSAM error (or 0 on success)

sysproxydistributors

The **sysproxydistributors** table contains information about the proxy distributors.

On the primary server, this table contains information about all of the proxy distributors in a high-availability cluster. On a secondary server, this table contains information about only those proxy distributors that are assigned to process updates to the secondary server.

Column	Type	Description
node_name	char	Name of the secondary server as it is known by the primary server (for example, INFORMIXSERVER, HA_ALIAS, and so on).
proxy_id	integer	ID of the proxy distributor. These IDs are unique within a high-availability cluster.
transaction_count	integer	Number of transactions currently being processed by the proxy distributor.
hot_row_total	integer	Total number of hot rows ever handled by the proxy distributor. A hot row is a row on a secondary server that is updated multiple times by more than one client. When a row is updated multiple times, the secondary server reads the before image from the primary server by placing an update lock on the row if the most recent update operation from a different session is not replayed on the secondary server.

sysproxysessions table

The **sysproxysessions** table contains information about each of the sessions that are using redirected-write functionality. This table is only valid on the secondary server.

The following table provides information about the columns in the **sysproxysessions** table:

Column	Type	Description
session_id	integer	ID of a user's session on the secondary server.
proxy_id	integer	ID of the proxy distributor on behalf of which the proxy agent thread (TID) is running
proxy_tid	integer	Transaction ID of the proxy agent thread running on the primary server. This ID is created by the proxy distributor to handle work from the secondary server session.
proxy_txn_id	integer	Number of the current transaction. These numbers are unique to the proxy distributor.
current_seq	integer	The sequence number of the current operation in the current transaction.

Column	Type	Description
pending_ops	integer	The number of operations buffered on the secondary server that have not yet been sent to the primary server.
reference_count	integer	Indicates the number of threads (for example, sqlexec, sync reply, recovery, and so on) that are using the information for this transaction. When reference_count equals 0, the transaction processing has completed (either successfully or unsuccessfully).

sysproxytxnops table

The **sysproxytxnops** table contains information about each of the transactions that are running through each proxy distributor.

On the primary server, this table contains information about all of the proxy distributors in the high-availability cluster. On a secondary server, this table only contains information about the proxy distributors used to process updates to the secondary server.

The following table provides information about the columns in the **sysproxytxnops** table:

Column	Type	Description
proxy_id	integer	ID of the proxy distributor. These IDs are unique within a high-availability cluster.
proxy_txn_id	integer	Number of the transaction. These numbers are unique to the proxy distributor.
sequence_number	integer	The number of the operation.
operation_type	char(10)	The type of operation to be performed; Insert, Update, Delete, or Other.
rowidn	integer	The ID of the row on which to apply the operation.
table	char	The full table name, trimmed to fit a reasonable length. Format: <i>database:owner.tablename</i>
sqlerrno	integer	Error number of any SQL error (or 0 on success)

sysproxytxns table

The **sysproxytxns** table contains information about all of the current transactions that are running through each proxy distributor.

On the primary server, this table contains information about each of the proxy distributors in the high-availability cluster. On a secondary server, this table only contains information about the proxy distributors used to process updates to the secondary server.

The following table provides information about the columns in the **sysproxytxns** table:

Column	Type	Description
proxy_id	integer	ID of the proxy distributor. These IDs are unique within a high-availability cluster.

Column	Type	Description
proxy_txn_id	integer	Number of the transaction. These numbers are unique to the proxy distributor.
reference_count	integer	Indicates the number of threads (for example, sqlexec, sync reply, recovery, and so on) that are using the information for this transaction. When the count becomes 0 this indicates the transaction processing is complete. (either successfully or unsuccessfully).
pending_ops	integer	On the primary server: the number of operations received from the secondary server that have not yet been processed. On the secondary server, the number of operations buffered on the secondary server that have not yet been sent to the primary server.
proxy_sid	integer	Proxy Session ID

sysptprof table

The **sysptprof** table lists information about a tblspace. Tblspaces correspond to tables.

Profile information for a table is available only when a table is open. When the last user who has a table open closes it, the tblspace in shared memory is freed, and any profile statistics are lost.

The following table provides information about the columns in the **sysptprof** table:

Column	Type	Description
dbname	char(128)	Database name
tablename	char(128)	Table name
partnum	integer	Partition (tblspace) number
lockreqs	integer	Number of lock requests
lockwts	integer	Number of lock waits
deadlks	integer	Number of deadlocks
lktouts	integer	Number of lock timeouts
isreads	integer	Number of isreads
iswrites	integer	Number of iswrites
isrewrites	integer	Number of isrewrites
isdeletes	integer	Number of isdeletes
bufreads	integer	Number of buffer reads
bufwrites	integer	Number of buffer writes
seqscans	integer	Number of sequential scans
pagreads	integer	Number of page reads
pagwrites	integer	Number of page writes

sysrepevtreg table

Use the **sysrepevtreg** pseudo table to register for a pre-defined set of events from the Connection Manager, the IBM OpenAdmin Tool (OAT) for Informix, or any

client application. After registering events through the **sysrepevtreg** pseudo table, Connection Manager, OAT, or any client application can receive event data by querying the table.

The following table provides information about the columns in the **sysrepevtreg** table:

Column	Type	Description
evt_bitmap	integer	Event ID bitmap
evt_timeout	integer	Maximum time in seconds that the client can wait for event data. Valid timeout values are: <ul style="list-style-type: none"> • 0; no wait (default) • -1; wait forever • <i>n</i> (where <i>n</i> > 0) wait <i>n</i> seconds
evt_hwm	integer	Pending event list high-water mark
evt_info	char(256)	Event information (Not yet implemented)

sysrepstats table

Use the **sysrepstats** table to post events to Connection Manager and to the IBM OpenAdmin Tool (OAT) for Informix. Connection Manager, OAT, and client applications can communicate with each other by posting events to the **sysrepstats** pseudo table.

The following table provides information about the columns in the **sysrepstats** table:

Column	Type	Description
repstats_type	integer	Event ID
repstats_subtype	integer	Sub event ID
repstats_time	integer	Time at which event was initiated
repstats_ver	integer	Version number of event data
repstats_desc	lvarchar	Event data

User Interface for sysrepstats and sysrepevtreg Tables

Client applications can post events to Connection Manager or to other clients by inserting event information into the **sysrepstats** pseudo table. Client applications can register events using the sysmaster pseudo table **sysrepevtreg**, and receive event data by issuing select or fetch statements against the **sysrepstats** pseudo table.

Posting events to the **sysrepstats** pseudo table provides the ability for programs such as the IBM OpenAdmin Tool (OAT) for Informix to communicate with Connection Manager. By posting events to the **sysrepstats**, you can issue control messages to Connection Manager without having to directly connect to Connection Manager itself.

When Connection Manager registers that it wishes to receive events, it passes a bitmap of the event types that it wants to receive. As events are received, they are posted to the thread that placed the request.

Event Classes

The following table lists each event class, its bit value, and a description of the event class.

Event class name	Bit value	Description
REPEVT_CLUST_CHG	0x1	Event class for High-Availability cluster changes
REPEVT_CLUST_PERFSTAT	0x2	Event class for workload statistics for the server nodes in a High-Availability cluster
REPEVT_CLUST_LATSTAT	0x4	Event class for replication latency information for server nodes in a High-Availability cluster
REPEVT_CM_ADM	0x8	Connection Manager administration commands
REPEVT_SRV_ADM	0x10	Event class for server mode changes
REPEVT_ER_ADM	0x20	Event class for events related to Enterprise Replication (ER)
REPEVT_CLIENT	0x40	User-defined client event

Sub-events for the Event Class REPEVT_CLUST_CHG

The following table lists sub-events for the event class REPEVT_CLUST_CHG:

Sub-event name	Value	Description	Event available at:
REPEVT_SUB_CLUST_ADD	1	Adding new node to a High-Availability cluster	Only at primary server in a High-Availability cluster
REPEVT_SUB_CLUST_DROP	2	Dropping a node from a High-Availability cluster	Only at primary server in a High-Availability cluster
REPEVT_SUB_CLUST_CON	3	High-Availability secondary node connected to primary server	Only at primary server in a High-Availability cluster
REPEVT_SUB_CLUST_DIS	4	High-Availability secondary node disconnected from primary server	Only at primary server in a High-Availability cluster
REPEVT_SUB_CLUST_NEWPRIM	5	High-Availability primary node changed	Only at secondary servers in a High-Availability cluster
REPEVT_SUB_CLUST_DROFF	6	HDR secondary node disconnected from primary server	HDR primary and secondary servers
REPEVT_SUB_CLUST_DRON	7	HDR secondary node connected to primary server	HDR primary and secondary servers

Sub-events for the Event Class REPEVT_CLUST_PERFSTAT

The following table lists sub-events for the event class REPEVT_CLUST_PERFSTAT:

Sub-event name	Value	Description	Event available at:
REPEVT_SUB_LOCAL_PERFSTAT	1	Work load statistics for local server	All servers in a High-Availability cluster
REPEVT_SUB_REMOTE_PERFSTAT	2	Work load statistics for High-Availability secondary servers	Only at the primary server in a High-Availability cluster

Sub-events for the Event Class REPEVT_CLUST_LATSTAT

The following table lists sub-events for the event class REPEVT_CLUST_LATSTAT:

Sub-event name	Value	Description	Event available at:
REPEVT_SUB_LOCAL_LATSTAT	1	Replication latency statistics for secondary servers in a High-Availability cluster	Only at the primary server in a High-Availability cluster

Sub-events for the Event Class REPEVT_CM_ADM

The following table lists sub-events for the event class REPEVT_CM_ADM:

Sub-event name	Value	Description	Event available at:
REPEVT_SUB_CM_ADM_REQ	1	Command request	All Informix server instances
REPEVT_SUB_CM_ADM_ACK	2	Command response	All Informix server instances
REPEVT_SUB_CM_REG	3	Connection Manager registered with server	All Informix server instances
REPEVT_SUB_CM_DEREG	4	Connection Manager de-registered with server	All Informix server instances
REPEVT_SUB_CM_FATAL	5	Connection Manager terminated without de-registering with server	All Informix server instances

Sub-events for the Event Class REPEVT_SRV_ADM

The following table lists sub-events for the event class REPEVT_SRV_ADM:

Sub-event name	Value	Description	Event available at:
REPEVT_SUB_SRV_BLK	1	Server blocked due to DDRBLOCK	All Informix server instances

Sub-event name	Value	Description	Event available at:
REPEVT_SUB_SRV_UBLK	2	Server unblocked; DDRBLOCK removed	All Informix server instances

Sub-events for the Event Class REPEVT_ER_ADM

The following table lists sub-events for the event class REPEVT_ER_ADM:

Sub-event name	Value	Description	Event available at:
REPEVT_SUB_ER_SPOOL_FULL	1	ER blocked while waiting for space to be added in either the queue data sbspace or dbspace, or in the grouper paging sbspace.	Enterprise Replication server nodes

sysrsslog

The **sysrsslog** table captures information about RS secondary servers at the primary server.

Column	Type	Description
server_name	char(128)	Server name
from_cache	integer	Total pages read from log buffer cache
from_disk	integer	Total pages read from disk
logpages_tossed	integer	Total number of log pages not written to log buffer cache

sysyclst

These columns of the **sysyclst** table provide information about session memory amounts.

Column	Type	Description
memtotal	integer	Total memory available
memused	integer	Total memory used

sysappinfo

The **sysappinfo** table in the **sysmaster** displays information on Distributed Relational Database Architecture (DRDA) client sessions. The **sysappinfo** table has the following columns.

Column	Type	Explanation
sesapp_sid	INTEGER	Client session ID
sesapp_name	CHAR(128)	Session application name
sesapp_value	CHAR(512)	Session value

sysstesprof

The **sysstesprof** table lists cumulative counts of the number of occurrences of user actions such as writes, deletes, or commits.

Column	Type	Description
sid	integer	Session ID
lockreqs	integer	Number of locks requested
locksheld	integer	Number of locks currently held
lockwts	integer	Number of times waited for a lock
deadlks	integer	Number of deadlocks detected
lktouts	smallint	Number of deadlock time-outs
logrecs	integer	Number of logical-log records written
isreads	integer	Number of reads
iswrites	integer	Number of writes
isrewrites	integer	Number of rewrites
isdeletes	integer	Number of deletes
iscommits	integer	Number of commits
isrollbacks	integer	Number of rollbacks
longtxs	integer	Number of long transactions
bufreads	integer	Number of buffer reads
bufwrites	integer	Number of buffer writes
seqscans	integer	Number of sequential scans
pagreads	integer	Number of page reads
pagwrites	integer	Number of page writes
total_sorts	integer	Number of total sorts
dsksorts	integer	Number of sorts that did not fit in memory
max_sortdiskspace	integer	Maximum space used by a sort
logspused	integer	Number of bytes of logical-log space used by current transaction of session
maxlogsp	integer	Maximum number of bytes of logical-log usage for any single transaction since the session started

syssessions

The **syssessions** table provides general information on each user connected to the database server. In the **state** column, each bit position represents a separate flag. Thus, it might be easier to read values in the **state** column if the values are returned using the HEX function.

Column	Type	Description
sid	integer	Session ID
username	char(32)	User ID
uid	smallint	User ID number
pid	integer	Process ID of the client

Column	Type	Description		
hostname	char(16)	Hostname of client		
tty	char(16)	Name of the user's stderr file		
connected	integer	Time that user connected to the database server		
feprogram	char(255)	Absolute path of the executable program or application		
pooladdr	integer	Session pool address		
is_wlatch	integer	1 if the primary thread for the session is waiting for a latch		
is_wlock	integer	1 if the primary thread for the session is waiting for a lock		
is_wbuff	integer	1 if the primary thread for the session is waiting for a buffer		
is_wckpt	integer	1 if the primary thread for the session is waiting for a checkpoint		
is_wlogbuf	integer	1 if the primary thread for the session is waiting for a log buffer		
is_wtrans	integer	1 if the primary thread for the session is waiting for a transaction		
is_monitor	integer	1 if the session is a special monitoring process		
is_incrit	integer	1 if the primary thread for the session is in a critical section		
state	integer	Flags	Hexadecimal	Meaning
		1	0x00000001	User structure in use
		2	0x00000002	Waiting for a latch
		4	0x00000004	Waiting for a lock
		8	0x00000008	Waiting for a buffer
		16	0x00000010	Waiting for a checkpoint
		32	0x00000020	In a read call
		64	0x00000040	Writing logical-log file to backup tape
		128	0x00000080	ON-Monitor (UNIX)
		256	0x00000100	In a critical section
		512	0x00000200	Special daemon
		1024	0x00000400	Archiving
		2048	0x00000800	Clean up dead processes
		4096	0x00001000	Waiting for write of log buffer
		8192	0x00002000	Special buffer-flushing thread
		16384	0x00004000	Remote database server
		32768	0x00008000	Deadlock timeout used to set RS_timeout
65536	0x00010000	Regular lock timeout		
262144	0x00040000	Waiting for a transaction		
524288	0x00080000	Primary thread for a session		
1048576	0x00100000	Thread for building indexes		
2097152	0x00200000	B-tree cleaner thread		

sysstmx

The `sysstmx` table provides SMX (server multiplexer group) connection information.

Column	Type	Description
<code>address</code>	int8	SMX pipe address
<code>name</code>	char(128)	Target server name
<code>encryption_status</code>	char(20)	Enabled or disabled
<code>buffers_sent</code>	integer	Number of buffers sent
<code>buffers_rcv</code>	integer	Number of buffers received
<code>bytes_sent</code>	int8	Number of bytes sent
<code>bytes_rcv</code>	int8	Number of bytes received
<code>reads</code>	integer	Number of read calls
<code>writes</code>	integer	Number of write calls
<code>retries</code>	integer	Number of write call retries

sysstmxses

The `sysstmxses` table provides SMX (server multiplexer group) session information.

Column	Type	Description
<code>name</code>	char(128)	Target server name
<code>address</code>	int8	SMX session address
<code>client_type</code>	char(20)	SMX client type
<code>reads</code>	integer	Number of read calls
<code>writes</code>	integer	Number of write calls

syssexplain table

The `syssexplain` pseudo table stores information about SQL queries if recording this information is enabled by the SET EXPLAIN statement. The information stored includes the plan of the query optimizer, an estimate of the number of rows returned, and the relative cost of the query.

Table 2-4. The `syssexplain` pseudo table

Column	Type	Description
<code>sqx_sessionid</code>	INTEGER	The session ID associated with the SQL statement.
<code>sqx_sdbno</code>	INTEGER	The position of the query in the array of session IDs.
<code>sqx_iscurrent</code>	CHAR	Whether the query is the current SQL statement.
<code>sqx_executions</code>	INTEGER	The total number of executions of the query.
<code>sqx_cumtime</code>	FLOAT	The cumulative time to run the query.
<code>sqx_bufreads</code>	INTEGER	The number of buffer reads performed while running the query.
<code>sqx_pagereads</code>	INTEGER	The number of page reads performed while running the query.

Table 2-4. The `syssexplain` pseudo table (continued)

Column	Type	Description
<code>sqx_bufwrites</code>	INTEGER	The number of buffer writes performed while running the query.
<code>sqx_pagewrites</code>	INTEGER	The number of page writes performed while running the query.
<code>sqx_totsorts</code>	INTEGER	The total number of sorts performed while running the query.
<code>sqx_dsksorts</code>	INTEGER	The number of disk sorts performed while running the query.
<code>sqx_sortspmax</code>	INTEGER	The maximum disk space required by a sort.
<code>sqx_conbno</code>	SMALLINT	The position in the conblock list.
<code>sqx_ismain</code>	CHAR	Whether the query is in the main block for the statement.
<code>sqx_selflag</code>	VARCHAR(200,0)	The type of SQL statement, for example: SELECT, UPDATE, DELETE.
<code>sqx_estcost</code>	INTEGER	The estimated cost of the query.
<code>sqx_estrows</code>	INTEGER	The estimated number of rows returned by the query.
<code>sqx_seqscan</code>	SMALLINT	The number of sequential scans used by the query.
<code>sqx_srtscan</code>	SMALLINT	The number of sort scans used by the query.
<code>sqx_autoindex</code>	SMALLINT	The number of autoindex scans used by the query.
<code>sqx_index</code>	SMALLINT	The number of index paths used by the query.
<code>sqx_remsql</code>	SMALLINT	The number of remote paths used by the query.
<code>sqx_mrgjoin</code>	SMALLINT	The number of sort-merge joins used by the query.
<code>sqx_dynhashjoin</code>	SMALLINT	The number of dynamic hash joins used by the query.
<code>sqx_keyonly</code>	SMALLINT	The number of key-only scans used by the query.
<code>sqx_tempfile</code>	SMALLINT	The number of temporary files used by the query.
<code>sqx_tempview</code>	SMALLINT	The number of temporary tables for views created by the query.
<code>sqx_secthread</code>	SMALLINT	The number of secondary threads used by the query.
<code>sqx_sqlstatement</code>	CHAR	The SQL query that was run.

syssqltrace

The `syssqltrace` table provides detailed information about a single SQL statement.

Column	Type	Description
<code>sql_id</code>	int8	Unique SQL execution ID
<code>sql_address</code>	int8	Address of the statement in the code block
<code>sql_sid</code>	int	Database session ID of the user running the SQL statement
<code>sql_uid</code>	int	User ID of the statement running the SQL
<code>sql_stmnttype</code>	int	Statement type

Column	Type	Description
sql_stmtname	char(40)	Statement type displayed as a word
sql_finishtime	int	Time this statement completed (UNIX)
sql_begintxtime	int	Time this transaction started
sql_runtime	float	Statement execution time
sql_pgreads	int	Number of disk reads for this SQL statement
sql_bfreads	int	Number of buffer reads for this SQL statement
sql_rdcache	float	Percentage of time the page was read from the buffer pool
sql_bfidxreads	int	Number of index page buffer reads
sql_pgwrites	int	Number of pages written to disk
sql_bfwrites	int	Number of pages modified and returned to the buffer pool
sql_wrcache	float	Percentage of time a page was written to the buffer pool but not to disk
sql_lockreq	int	Total number of locks required by this SQL statement
sql_lockwaits	int	Number of times the SQL statement waited on locks
sql_lockwtime	float	Time the system waited for locks during SQL statement
sql_logspace	int	Amount of space the SQL statement used in the logical log
sql_sorttotal	int	Number of sorts that ran for the statement
sql_sortdisk	int	Number of sorts that ran on disk
sql_sortmem	int	Number of sorts that ran in memory
sql_executions	int	Number of times the SQL statement ran
sql_totalltime	float	Total amount of time spent running the statement
sql_avgtime	float	Average amount of time spent running the statement
sql_maxtime	float	Maximum amount of time spent executing the SQL statement
sql_numioawaits	int	Number of times an I/O operation had to wait
sql_avgioawaits	float	Average amount of time that the SQL statement had to wait
sql_taliowaits	float	Total amount of time that the SQL statement had to wait for I/O. This excludes any asynchronous I/O.
sql_rowspersec	float	Average number of rows (per second) produced
sql_estcost	int	Cost associated with the SQL statement
sql_estrows	int	Estimated number of rows returned for the SQL statement as predicted by the optimizer
sql_actualrows	int	Number of rows returned for the SQL statement
sql_sqlerror	int	SQL error number
sql_isamerror	int	RSAM/ISAM error number
sql_isollevel	int	Isolation level of the SQL statement.
sql_sqlmemory	int	Number of bytes needed to execute the SQL statement
sql_numiterators	int	Number of iterators used by the statement
sql_database	char(128)	Database name

Column	Type	Description
sql_numtables	int	Number of tables used in executing the SQL statement
sql_tablelist	char(4096)	List of table names directly referenced in the SQL statement. If the SQL statement fires triggers that execute statements against other tables, the other tables are not listed.
sql_statement	char(1600)	SQL statement that ran

sysssqltrace_info

The `sysssqltrace_info` table describes information about the SQL profile trace system.

Column	Type	Description
flags	integer	SQL trace flags
ntraces	integer	Number of items to trace
tracesize	integer	Size of the text to store for each SQL trace item
duration	integer	Trace buffer (in seconds)
sqlseen	int8	Number of SQL items traced since start or resizing
starttime	integer	Time tracing was enabled
memoryused	int8	Number of bytes of memory used by SQL tracing

sysssqltrace_iter

The `sysssqltrace_iter` table lists the SQL statement iterators.

Column	Type	Description
sql_id	int8	SQL execution ID
sql_address	int8	Address of the SQL statement block
sql_itr_address	int8	Address of the iterator
sql_itr_id	int	Iterator ID
sql_itr_left	int	Iterator ID to the left
sql_itr_right	int	Iterator ID to the right
sql_itr_cost	int	Iterator cost
sql_itr_estrows	int	Iterator estimated rows
sql_itr_numrows	int	Iterator actual rows processed
sql_itr_type	int	Iterator type
sql_itr_misc	int	Iterator miscellaneous flags
sql_it_info	char(256)	Iterator miscellaneous flags displayed as text

syssrcrss

The `syssrcrss` table provides RS secondary server related statistics at the primary server.

Column	Type	Description
address	int8	RS secondary server control block address
server_name	char(128)	Database server name
server_status	char(20)	Quiescent, active, or inactive
connection_status	char(20)	Connected or disconnected
log_transmission_status	char(20)	Active or blocked
next_page_tosend_log_uniq	integer	Unique log ID of next page to send
next_page_tosend_log_page	integer	Page number of next page to send
seq_tosend	integer	Sequence ID of last buffer sent
last_seq_acked	integer	Sequence ID of last buffer acknowledged

syssrcsds

The `sysrcsds` table provides SD secondary server related statistics at the primary server.

The `sysrcsds` table contains these columns:

Column	Type	Description
address	int8	SD secondary server control block address
source_server	char(128)	Primary database server name
connection_status	char(20)	Connected or disconnected
last_received_log_uniq	integer	Unique log ID of last log page received
last_received_log_page	integer	Page number of last log page received
next_lpgtoread_log_uniq	integer	Unique log ID of next log page to read
next_lpgtoread_log_page	integer	Page number of next log page to read
last_acked_lsn_uniq	integer	Unique log ID of last LSN acknowledged
last_acked_lsn_pos	integer	Log position of last LSN acknowledged
last_seq_received	integer	Sequence ID of last buffer received
last_seq_acked	integer	Sequence ID of last buffer acknowledged
cur_pagingfile	char(640)	Current paging file name
cur_pagingfile_size	int8	Current paging file size
old_pagingfile	char(640)	Old paging file name
old_pagingfile_size	int8	Old paging file size

sysstabnames

The `sysstabnames` table describes each table that the database server manages.

Column	Type	Description
partnum	integer	tblspace identifier
dbname	char(128)	Database name
owner	char(32)	User ID of owner
tablename	char(128)	Table name

Column	Type	Description
collate	char(32)	Collation associated with a database that supports GLS

systhreads

The **systhreads** table provides information about each thread.

Column	Type	Description
th_id	INTEGER	The numeric identifier of the thread.
th_addr	INTEGER	The memory address of the thread control block.
th_joinlist	INTEGER	If a list of the threads are waiting for this thread to exit, the th_joinlist column shows the address of the first thread in the list.
th_joinnext	INTEGER	If a list of the threads are waiting for this thread to exit, the th_joinnext column shows the address of the next thread in the join list.
th_joinee	INTEGER	The address of the thread whose exit this thread is waiting for.
th_name	CHAR(12)	The name of the thread.
th_state	INTEGER	The status code of the thread.
th_priority	INTEGER	The priority of the thread.
th_class	INTEGER	The code for the class of virtual processor that thread will run on.
th_vpid	INTEGER	The ID of the virtual processor that the thread was last scheduled to run on.
th_mtxwait	INTEGER	The address of the mutex that this thread is waiting for.
th_conwait	INTEGER	The address of the condition that this thread is waiting for.
th_waketime	INTEGER	The time of the expiration of the last sleep. The time is calculated by an internal clock. A value of -1 means that the time value is indeterminate.
th_startwait	INTEGER	The time when the last wait began. The time is calculated by an internal clock.
th_startrun	INTEGER	The time when the last execution began. The time is calculated by an internal clock.

systgrss

The **systgrss** table provides RS secondary server related statistics at the RS secondary server.

Column	Type	Description
address	int8	RS secondary server control block address
source_server	char(128)	Source server serving the RS secondary server
connection_status	char(20)	Connected or disconnected
last_received_log_uniq	integer	Unique log ID of last log page received
last_received_log_page	integer	Page number of last log page received
last_seq_received	integer	Sequence ID of last buffer received

Column	Type	Description
last_seq_acked	integer	Sequence ID of last buffer acknowledged

systrgsds

The **systrgsds** table provides SD secondary server related statistics at the SD secondary server.

The **systrgsds** table contains these columns:

Column	Type	Description
address	int8	SD secondary server control block address
source_server	char(128)	Source server serving the SD secondary server
connection_status	char(20)	Connected or disconnected
last_received_log_uniq	integer	Unique log ID of last log page received
last_received_log_page	integer	Page number of last log page received
next_lptoread_log_uniq	integer	Unique log ID of next log page to read
next_lptoread_log_page	integer	Page number of next log page to read
last_acked_lsn_uniq	integer	Unique log ID of last LSN acknowledged
last_acked_lsn_pos	integer	Log position of last LSN acknowledged
last_seq_received	integer	Sequence ID of last buffer received
last_seq_acked	integer	Sequence ID of last buffer acknowledged
cur_pagingfile	char(640)	Current paging file name
cur_pagingfile_size	int8	Current paging file size
old_pagingfile	char(640)	Old paging file name
old_pagingfile_size	int8	Old paging file size

sysvpprof

The **sysvpprof** table lists user and system CPU time for each virtual processor.

Column	Type	Description
vpid	integer	Virtual processor ID
	char(50)	Type of virtual processor: <ul style="list-style-type: none"> • cpu • adm • lio • pio • aio • tli • soc • str • shm • opt • msc • adt

syslogs	sysprofile	sysptprof	sysesprof	sysessions
number	name	dbsname	sid	sid
uniqid	value	tablename	lockreqs	username
size		partnum	locksheld	uid
used		lockreqs	lockwts	pid
is_used		lockwts	deadlks	hostname
is_current		deadlks	lktouts	tty
is_backed_up		lktouts	logrecs	connected
is_new		isreads	isreads	feprogram
is_archived		iswrites	iswrites	pooladdr
is_temp		isrewrites	isrewrites	is_wlatch
flags		isdeletes	isdeletes	is_wlock
		bufreads	iscommits	is_wbuff
		bufwrites	isrollbacks	is_wckpt
		seqscans	longtxs	is_wlogbuf
		pagreads	bufreads	is_wtrans
		pagwrites	bufwrites	is_monitor
			seqscans	is_incrit
			pagreads	state
			pagwrites	
			total_sorts	
			dsksorts	
			max_sort diskpace	
			logspused	
			maxlogsp	

syseswts	systabnames	sysvpprof
sid	partnum	vpid
reason	dbsname	class
numwaits	owner	usercpu
cumtime	tablename	syscpu
maxtime	collate	

Information from onstat in the SMI Tables

To obtain information provided by the **onstat** utility, you can use SQL to query appropriate SMI tables. The following table indicates which SMI tables to query to obtain the information provided by a given **onstat** option. For descriptions of the **onstat** options, see “Monitor the database server status” on page 21-18.

onstat Option	SMI Tables to Query	onstat Fields <i>Not</i> in SMI Tables
-d	sysdbspaces syschunks	address bpages
-D	sysdbspaces syschkio	
-F	sysprofile	address flusher snoozer state data
-g ath	systhreads	

onstat Option	SMI Tables to Query	onstat Fields <i>Not</i> in SMI Tables
-g dri	sysdri	Last DR CKPT (id/pg)
-g glo	sysvpprof	Listing of virtual processors by
-g ipl	sysipl	
-g rss	sysrsslog systgrss syssrcrs	
-g his	syssqltracing	
-g sds	syssrcsds systrgsds	
-g smx	sysmx	
-g smx ses	sysmxses	
-k	syslocks	address lklist tblsnum
-l	syslogs sysprofile	All physical-log fields (except numpages and numwrits) All logical-log buffer fields (except numrecs, numpages, and numwrits) address begin % used
-p	sysprofile	
-u	sysessions sysseprof	address wait nreads nwrites

Chapter 3. The sysadmin Database

The **sysadmin** database contains the tables that contain and organize the Scheduler tasks and sensors, store data collected by sensors, and record the results of Scheduler jobs and SQL administration API functions.

By default, only user **informix** is granted access to the **sysadmin** database; other users can be granted access to the **sysadmin** database.

Do not drop or alter the **sysadmin** database because it is used by several important database server components. You can, however, move the **sysadmin** database from its default root dbspace location if the root dbspace does not have enough space for storing task properties and command history information. To move the **sysadmin** database, use the SQL administration API **admin()** or **task()** function with the **reset sysadmin** argument.

Important: Moving the **sysadmin** database resets the database back to the original state when it was first created; all data, command history, and results tables are lost. Only built-in tasks, sensor, and thresholds remain in the **sysadmin** tables.

Related reference:

“reset sysadmin argument: Move the sysadmin database (SQL administration API)” on page 22-100

The Scheduler Tables

The Scheduler stores information about tasks and sensors in five tables in the **sysadmin** database: **ph_task**, **ph_run**, **ph_group**, **ph_alert**, and **ph_threshold**.

The Scheduler is an administrative tool that enables the database server to execute database functions and procedures at predefined times or as determined internally by the server. The five tables used by the Scheduler contain built-in tasks and sensors that run automatically. You can also add your own tasks and sensors by inserting rows into these tables. These tables have relationships between their columns that are described in the following illustration.

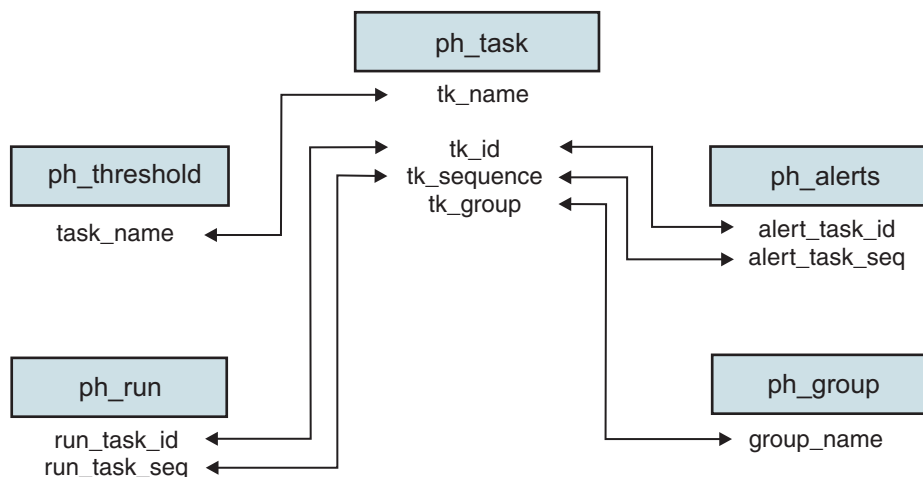

Figure 3-1. Relationships between the Scheduler tables

For detailed information about using the Scheduler, see the *IBM Informix Administrator's Guide*.

Related concepts:

[📄 Scheduler tables \(Administrator's Guide\)](#)

The **ph_task** Table

The **ph_task** table contains information about Scheduler tasks and sensors. The **ph_task** table contains built-in tasks and sensors that are scheduled to run automatically.

Table 3-1. The ph_task table

Column	Type	Description
tk_id	serial	Sequential job ID. System updated; do not modify. Referenced in the alert_task_id column in the ph_alert table and in the run_task_id column in the ph_run table.
tk_name	char(36)	Job name. A unique index on this column ensures that no two names are the same. Referenced in the task_name column of the ph_threshold table.
tk_description	lvvarchar	Description about what the task or sensor does.
tk_type	char(18)	Type of job: <ul style="list-style-type: none"> • TASK: Invokes an action at a specific time and frequency • SENSOR: (Default) A task that collects, stores, and purges data to or from a result table • STARTUP TASK: A task that runs only when the server starts • STARTUP SENSOR: A sensor that runs only when the server starts
tk_sequence	integer	Current data collection number. System updated; do not modify. Referenced in the alert_task_id column of the ph_alert table and the run_task_seq column of the ph_run table.
tk_result_table	vvarchar	Results table name for storing data collected by a sensor. The table is created by the CREATE TABLE statement in the tk_create column.
tk_create	lvvarchar	The CREATE TABLE statement used to create the results table to store data collected by a sensor. One of the columns in the table must be named ID and hold the tk_sequence value. This value indicates the age of the row and can be used for purging the row.

Table 3-1. The *ph_task* table (continued)

Column	Type	Description
tk_dbs	varchar(250)	The database in which the task is run. Default is sysadmin.
tk_execute	lvarchar	The SQL statement to execute.
tk_delete	interval day(2) to second	Data older than this interval is deleted from the result table. Default is 1:00:00 (one day).
tk_start_time	datetime hour to second	Time when the task or sensor starts. Default is 08:00:00.
tk_stop_time	datetime hour to second	Time of day after which the task or sensor cannot be scheduled to be run. The database server schedules the next execution on the next valid day. Default is 19:00:00. Can be NULL, indicating no stop time.
tk_frequency	interval day(2) to second	How often this task or sensor runs. Default is 1 (once a day).
tk_next_execution	datetime year to second	Next time this task or sensor will be run. After a startup task or sensor has run, this value is NULL. When a task or a sensor is enabled, the database server calculates this time from the values of tk_start_time , tk_stop_time , and tk_frequency columns, and the days of the week the task or sensor is enabled, according to the values of tk_monday , tk_tuesday , tk_wednesday , tk_thursday , tk_friday , tk_saturday , tk_sunday columns.
tk_total_executions	integer	The number of times that the task or sensor was run. System updated; do not modify. Default is 0.
tk_total_time	float	Total time spent executing this task or sensor. System updated; do not modify Default is 0.0 seconds.
tk_monday	boolean	Whether the task or sensor is run on Monday. Default is T (true).
tk_tuesday	boolean	Whether the task or sensor is run on Tuesday. Default is T (true).
tk_wednesday	boolean	Whether the task or sensor is run on Wednesday. Default is T (true).

Table 3-1. The *ph_task* table (continued)

Column	Type	Description
tk_thursday	boolean	Whether the task or sensor is run on Thursday. Default is T (true).
tk_friday	boolean	Whether the task or sensor is run on Friday. Default is T (true).
tk_saturday	boolean	Whether the task or sensor is run on Saturday. Default is T (true).
tk_sunday	boolean	Whether the task or sensor is run on Sunday. Default is T (true).
tk_attributes	integer	Flags System updated; do not modify.
tk_group	varchar(128)	Group name. Must be the same as a value in the group_name column in the ph_group table. Default is MISC.
tk_enable	boolean	Whether the task or sensor is enabled. Default is T (the task is enabled).
tk_priority	integer	Job priority, on a scale of 0- 5, with higher numbers indicating higher priority. If there are several jobs to execute simultaneously, the job with the highest priority executes first. Default is 0 (low priority).

The **ph_run** Table

The **ph_run** table contains information about how and when each Scheduler task or sensor ran.

Table 3-2. The *ph_run* table

Column	Type	Description
run_id	serial	Sequential ID generated during execution. System updated; do not modify.
run_task_id	integer	The job ID. Referenced from the tk_id column of the ph_task table.
run_task_seq	integer	Unique sequence number of the task or sensor. Referenced from the tk_sequence column of the ph_task table.
run_retcode	integer	The return code from a stored procedure function or a user-defined routine, or the SQLCode from SQL statements.

Table 3-2. The `ph_run` table (continued)

Column	Type	Description
<code>run_time</code>	datetime year to second	When this task or sensor was run.
<code>run_duration</code>	float	The time that it took to run this task or sensor (in seconds).
<code>run_ztime</code>	integer	The time when the server statistics (the <code>onstat -z</code> command) were last run.
<code>run_btime</code>	integer	The time when the server was started.
<code>run_mtttime</code>	integer	Internal counter of the server.

The `ph_group` Table

The `ph_group` table contains information about the Scheduler group names. The `ph_group` table contains several groups that are used to categorize built-in tasks and sensors, as well as the default group MISC.

Table 3-3. The `ph_group` table

Column	Type	Description
<code>group_id</code>	serial	Group ID. System updated; do not modify.
<code>group_name</code>	varchar(128)	Unique name of the group. Referenced in the <code>tk_group</code> column of the <code>ph_task</code> table.
<code>group_description</code>	lvarchar	Description of the group.

The `ph_alert` Table

The `ph_alert` table contains information about event alarms generated by the database server or alerts generated by the Scheduler. Alerts that are associated with built-in tasks and sensors are automatically added to the `ph_alert` table.

Table 3-4. The `ph_alert` table

Column	Type	Description
<code>id</code>	serial	The alert ID. System generated; do not modify.
<code>alert_task_id</code>	serial	The task or sensor ID. Must be the same as a value in the <code>tk_id</code> column in the <code>ph_task</code> table. The task ID for event alarms is 15.
<code>alert_task_seq</code>	integer	Identifies which invocation of a task created the alert. System generated; do not modify. Referenced from the <code>tk_sequence</code> column in the <code>ph_task</code> table.

Table 3-4. The *ph_alert* table (continued)

Column	Type	Description
alert_type	char(8)	The type of alert: <ul style="list-style-type: none"> • INFO (Default) • WARNING • ERROR <p>The severity of an alert or event alarm is indicated by the combination of the alert type and the alert color. See Table 3-5 on page 3-7.</p>
alert_color	char(15)	The color of the alert: <ul style="list-style-type: none"> • GREEN (Default) • YELLOW • RED <p>The severity of an alert or event alarm is indicated by the combination of the alert type and the alert color. See Table 3-5 on page 3-7.</p>
alert_time	datetime year to second	The time when the alert was generated. System updated; do not modify.
alert_state	char(15)	Indicates which state the object is in: <p>NEW (Default) The alert was added and no other action has occurred on this alert.</p> <p>IGNORED The alert was acknowledged by the DBA and no action was taken.</p> <p>ACKNOWLEDGED The alert was acknowledged by the DBA.</p> <p>ADDRESSED The alert was addressed by the DBA.</p>
alert_state_changed	datetime year to second	The last time that the state was changed. System updated; do not modify.
alert_object_type	char(15)	The type of object that the alert is for: <ul style="list-style-type: none"> • ALARM • CHUNK • DATABASE • DBSPACE • INDEX • MISC (Default) • SERVER • SQL_STATEMENT • TABLE • USER
alert_object_name	varchar(255)	The name of the object that the alert is for or the event alarm class ID.
alert_message	lvarchar	The detailed message describing the alert or event alarm.

Table 3-4. The `ph_alert` table (continued)

Column	Type	Description
<code>alert_action_dbs</code>	<code>lvvarchar(256)</code>	The name of the database to use for the corrective action. Default is <code>sysadmin</code> .
<code>alert_action</code>	<code>lvvarchar</code>	The corrective action. An SQL script to invoke to correct the problem. This script must comply with all multi-statement prepare rules. Can be NULL if no action is available.
<code>alert_object_info</code>	<code>bigint</code>	For alerts of type ALARM, the event ID of the event alarm.

The following table defines the alert colors for the three types of messages and event alarms.

Table 3-5. Alert types and colors

Message Type	Green	Yellow	Red
Informative	A status message indicating a component's operation status. An event alarm of severity 1 (not noteworthy).	An important status message. An event alarm of severity 2 (information).	A status message that requires action.
Warning	A warning from the database that was automatically addressed.	A future event that needs to be addressed. An event alarm of severity 3 (attention).	A predicted failure is imminent. Immediate action is required.
Error	A failure in a component corrected itself.	A failure in a component corrected itself but might need DBA action.	A failure in a component requires DBA action. An event alarm of severity 4 (emergency) or 5 (fatal).

The `ph_alerts` view shows alert information and associated task or sensor information.

Related concepts:

“Events in the `ph_alert` Table” on page C-3

The `ph_threshold` Table

The `ph_threshold` table contains information about thresholds for Scheduler tasks.

The **ph_threshold** table contains built-in thresholds that are associated with built-in tasks and sensors. For example, a threshold named COMMAND HISTORY RETENTION determines the length of time rows should remain in the **command_history** table.

Table 3-6. The *ph_threshold* table

Column	Type	Description
id	integer	Threshold ID.
name	char	The name of the threshold.
task_name	varchar	Scheduler task name associated with the threshold. Must be the same as a value in the tk_name column in the ph_task table.
value	lvarchar	The value of the threshold.
value_type	char	The data type of the value column: <ul style="list-style-type: none"> • STRING • NUMERIC • NUMERIC(p,s)
description	lvarchar	A long description of the threshold.

Results Tables

Results tables contain historical data about sensors that are run by the Scheduler.

Most sensors create a new table to store their results. The name of the table is listed in the **tk_result_table** column in the **ph_task** table. The structure of the table is defined by the CREATE TABLE statement in the **tk_create** column of the **ph_task** table.

The built-in sensors automatically create results tables when they run that start with the prefix **mon_**.

Table 3-7. Results tables

Column	Type	Description
ID	integer	The iteration sequence number of the sensor. Must be set to \$DATA_SEQ_ID. Referenced from the run_task_seq column of the ph_run table.
<i>user columns</i>	any	You can specify any types of columns to hold the information returned by a sensor.

The command_history table

The **command_history** table contains the list and results of all the SQL administration API functions that were run in the previous 30 days.

The **command_history** table shows each SQL administration API function that was run and displays information about the user who ran the function, the time the function was run, the primary arguments of the function, and the message returned when the database server completed running the function.

Table 3-8. The `command_history` table

Column	Data Type	Description
<code>cmd_number</code>	serial	The unique ID for each row.
<code>cmd_exec_time</code>	datetime year-to-second	The time that the function started.
<code>cmd_user</code>	varchar	The user who ran the function.
<code>cmd_hostname</code>	varchar	The name of the host computer from which the function was run.
<code>cmd_executed</code>	varchar	The primary argument of the function that was run.
<code>cmd_ret_status</code>	integer	Return code.
<code>cmd_ret_msg</code>	lvarchar	Return message.

The following table shows sample arguments and the associated results messages in a `command_history` table.

Table 3-9. Example information in a `command_history` table

Argument (<code>cmd_executed</code>)	Message Returned (<code>cmd_ret_msg</code>)
set sql tracing on	SQL tracing on with 1000 buffers of 2024 bytes.
create dbspace	Space 'space12' added.
checkpoint	Checkpoint completed.
add log	Added 3 logical logs to dbspace logdbs.

To display the command history, run the following SQL statement from the `sysadmin` database:

```
SELECT * FROM command_history;
```

The size of the `command_history` table

Depending on how many SQL administration API functions are run, the `command_history` table can grow quite large. You can change the amount of time that information is retained in the `command_history` table by updating the `value` field of the `COMMAND HISTORY RETENTION` row in the `ph_threshold` table.

You can also use SQL statements like `DELETE` or `TRUNCATE TABLE` to manually remove the data from this table.

Related tasks:

[Viewing SQL administration API history \(Administrator's Guide\)](#)

The `storagepool` table

The `storagepool` table in `sysadmin` database contains information about all of the entries in the storage pool in an Informix instance. Each entry represents free space that the server can use when automatically expanding a storage space.

Table 3-10. The `storagepool` table

Column	Type	Description
<code>entry_id</code>	SERIAL	The ID of the storage pool entry.

Table 3-10. The **storagepool** table (continued)

Column	Type	Description
path	VARCHAR (255)	The path for the file, directory, or device that the server can use when additional storage space is required.
beg_offset	BIGINT	The initial offset in kilobytes into the device at which the server can begin allocating space. If the storage pool information is for a directory, the end offset value is 0.
end_offset	BIGINT	The initial offset in kilobytes into the device at which the server must stop allocating space. If the storage pool information is for a directory, the offset value is 0.
chunk_size	BIGINT	The initial size of a chunk allocated from this entry.
status	VARCHAR (255)	The status of the storage pool entry. Status values are: Active = A functional storage pool entry. The server can allocate chunks from this entry. Full = There is no more free space in the storage pool entry. The server cannot allocate any more chunks from this entry. Error = The storage pool entry generated an error when the server tried to allocate a chunk from the entry.
priority	INT	The priority of the directory, file, or device when the server searches through the storage pool for space. The server allocates space from a high-priority entry before it allocates space from a lower priority entry. 1 = High priority 2 = Medium priority 3 = Low priority
last_alloc	DATETIME (year to second)	The date and time of the last allocation from this entry.
logid	INT	The ID of the log that was current at the time this entry was last used. The server uses this flag with the logused value when choosing between entries of identical priorities.
logused	INT	The position within the log that was current at the time this entry was last used. The server uses this flag with the logid value when choosing between entries of identical priorities.

Chapter 4. Disk Structures and Storage

In This Chapter

The database server achieves its high performance by managing its own I/O. The database server manages storage, search, and retrieval. As the database server stores data, it creates the structures it needs to search for and retrieve the data later. The database server disk structures also store and track control information needed to manage logging and backups. Database server structures contain all the information needed to ensure data consistency, both physical and logical.

Before you read this chapter, familiarize yourself with the disk-space terms and definitions in the chapter on where data is stored in the *IBM Informix Administrator's Guide*.

This chapter discusses the following topics related to disk data structures:

- Dbspace structure and storage
- Storage of simple large objects
- Sbspace structure
- Time stamps
- Database and table creation: what happens on disk

Dbspace Structure and Storage

This section explores the disk structures and storage techniques that the database server uses to store data in a dbspace.

Related concepts:

 [Forest of trees indexes \(Performance Guide\)](#)

Structure of the Root Dbspace

As part of disk-space initialization, the database server initializes specific structures in the initial chunk of the root dbspace.

The following structures are initialized:

- Twelve reserved pages
- The first chunk free-list page
- The tblspace tblspace
- The physical log
- The logical-log files
- The database tblspace

The `ROOTNAME`, `ROOTOFFSET`, `ROOTPATH`, and `ROOTSIZE` configuration parameters specify the size and location of the initial chunk of the root dbspace. If the root dbspace is mirrored, the `MIRROROFFSET` and `MIRRORPATH` configuration parameters specify the mirror-chunk location. For more information about these parameters, see Chapter 1, "Database configuration parameters," on page 1-1.

To see the structure of the root chunk use the **oncheck -pe** command. For more information, see “oncheck -ce, -pe: Check the chunk-free list” on page 9-10.

Reserved Pages

The first 12 pages of the initial chunk of the root dbspace are reserved pages. Each reserved page contains specific control and tracking information used by the database server.

To obtain a listing of the contents of your reserved pages, execute the command **oncheck -pr**. To also list information about the physical-log and logical-log pages, including the active physical-log pages, run the **oncheck -pR** command.

The following example shows sample **oncheck -pr** output for interval checkpoints:

```
Time of checkpoint      10/25/2005 17:05:20
Checkpoint Interval    1234
```

The database server also stores current configuration information in a reserved page called PAGE_CONFIG. If you change the configuration parameters from the command line and run the **oncheck -pr** command without shutting down and restarting the database server, the configuration values in the command output do not match the current values in the reserved pages. The **oncheck** utility returns a warning message.

The following example shows sample output of the contents of a PAGE_CONFIG reserved page.

...

Validating Informix database server reserved pages - PAGE_CONFIG

```
ROOTNAME                rootdbs
ROOTPATH                /home/dyn_srv/root_chunk
ROOTOFFSET              4
ROOTSIZE                8000
MIRROR                 0
MIRRORPATH
MIRROROFFSET           0
PHYSFILE                1000
LOGFILES                5
LOGSIZE                 500
MSGPATH                 /home/dyn_srv/online.log
CONSOLE                 /dev/tty5
```

...

...

Structure of a Regular Dbspace

After disk-space initialization, you can add new dbspaces. When you create a dbspace, you assign at least one chunk (either raw or cooked disk space) to the dbspace. This chunk is referred to as the initial chunk of the dbspace. Figure 4-1 on page 4-3 illustrates the structure of the initial chunk of a regular (nonroot) dbspace.

When the dbspace is first created, it contains the following structures:

- Two reserved pages
- The first chunk free-list page in the chunk
- The tblspace **tblspace** for this dbspace
- Unused pages

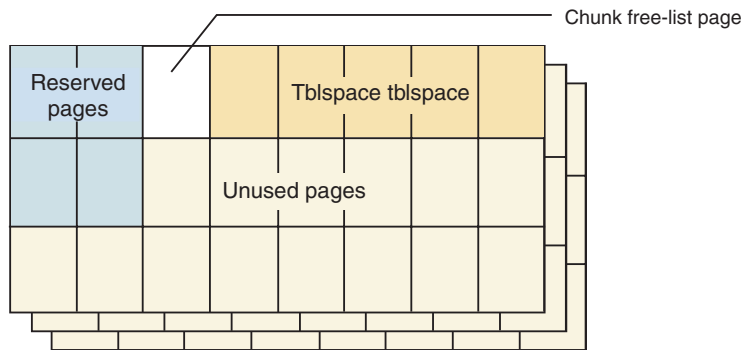

Figure 4-1. Initial Chunk of Regular Dbspace

Structure of an Additional Dbspace Chunk

You can create a dbspace that contains more than one chunk. The initial chunk in a dbspace contains the tblspace **tblspace** for the dbspace. Additional chunks do not. When an additional chunk is first created, it contains the following structures:

- Two reserved pages
- The first chunk free-list page
- Unused pages

Figure 4-2 illustrates the structure of all additional chunks in a dbspace. (The structure also applies to additional chunks in the root dbspace.)

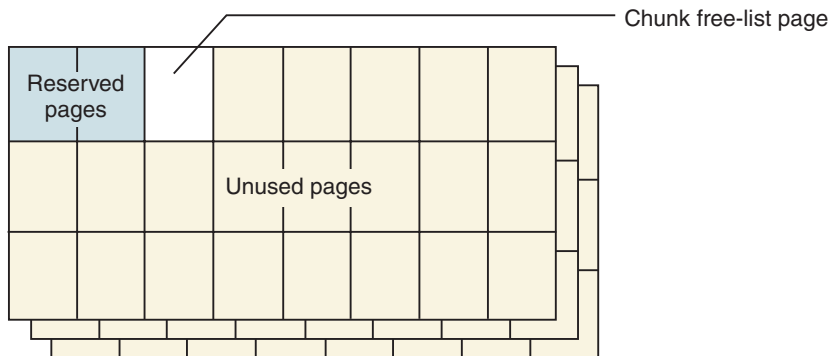

Figure 4-2. Additional Dbspace Chunk

Structure of a Mirror Chunk

Each mirror chunk must be the same size as its primary chunk. When a mirror chunk is created, the database server writes the contents of the primary chunk to the mirror chunk immediately.

The mirror chunk contains the same control structures as the primary chunk. Mirrors of blobspace, sbspace, or dbspace chunks contain the same physical contents as their primary counterpart after the database server brings them online.

Figure 4-3 on page 4-4 illustrates the mirror-chunk structure as it appears after the chunk is created.

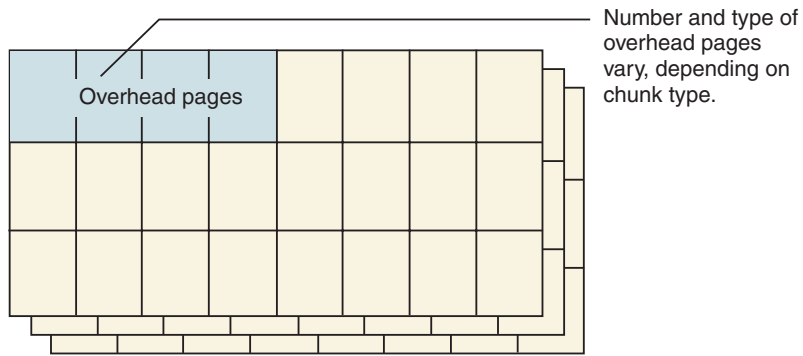

Figure 4-3. Mirror-Chunk Structure

The mirror-chunk structure always shows no free space because all of its space is reserved for mirroring. For more information, see the chapter on what is mirroring in the *IBM Informix Administrator's Guide*.

Structure of the Chunk Free-List Page

In every chunk, the page that follows the last reserved page is the first of one or more chunk free-list pages that tracks available space in the chunk. For a non-root chunk, the initial length of the free space is equal to the size of the chunk minus three pages. If an additional chunk free-list page is needed to accommodate new entries, a new chunk free-list page is created in one of the free pages in the chunk. Figure 4-4 illustrates the location of the free-list page.

Use **oncheck -pe** to obtain the physical layout of pages in the chunk. For more information, see “oncheck -ce, -pe: Check the chunk-free list” on page 9-10.

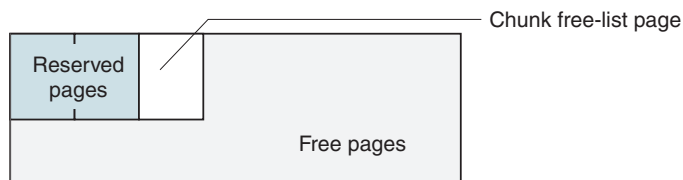

Figure 4-4. Free-List Page

Structure of the Tblspace Tblspace

Each dbspace contains a tblspace called the *tblspace tblspace* that describes all tblspaces in the dbspace. When the database server creates a tblspace, it places an entry in the *tblspace tblspace* that describes the characteristics of the newly created tblspace. You cannot drop or move a chunk containing a *tblspace tblspace*.

A dbspace can have a maximum number of 2^{20} tblspaces.

The default size of the first and next extents depends on whether the dbspace is the root dbspace or not, as shown in the following table.

Table 4-1. Default sizes for each extent and type of dbspace

Type of dbspace	Default Size of First Extent	Default Size of Next Extents
Root	<ul style="list-style-type: none"> • 500 KB for a 2 kilobyte page system • 1000 KB for a 4 kilobyte page system 	<ul style="list-style-type: none"> • 100 KB for a 2 kilobyte page system • 200 KB for a 4 kilobyte page system
Non-root	<ul style="list-style-type: none"> • 100 KB for a 2 kilobyte page system • 200 KB for a 4 kilobyte page system 	<ul style="list-style-type: none"> • 100 KB for a 2 kilobyte page system • 200 KB for a 4 kilobyte page system

You can specify a non-default size for the first and next extents for a **tblspace** in the following ways:

- For the root dbspace, set the **TBLTBLFIRST** and **TBLTBLNEXT** configuration parameters.
- For non-root dbspaces, use the **onspaces** utility **-ef** and **-en** options when you create a dbspace.

Tblspace Tblspace Entries

To display information on the **tblspace**, use the **oncheck -pt** command. For more information, see “**oncheck -pt** and **-pT**: Display **tblspaces** for a Table or Fragment” on page 9-19.

Component	Description
Page header	24 bytes, standard page-header information
Page-ending time stamp	4 bytes
Tblspace header	68 bytes, general tblspace information
Column information	Each special column in the table is tracked with an 12-byte entry. (A special column is defined as a VARCHAR , BYTE , or TEXT data type.)
Tblspace name	80 bytes, <i>database.owner.tblspace</i>
Index information	Each index on the table contains a 20-byte header that contains general information about the index, followed by a 4-byte entry for each column component of the index
Extent information	Each extent allocated to this tblspace is tracked with a 12-byte entry

Tblspace Numbers

Each **tblspace** that is described in the **tblspace** **tblspace** receives a **tblspace** number. This **tblspace** number is the same value that is stored as the **partnum** field in the **sysables** system catalog table and as the **partn** field in the **sysfragments** system catalog table.

The following SQL query retrieves the **partnum** for every table in the database (these can be located in several different **dbspaces**) and displays it with the table name and the hexadecimal representation of **partnum**:

```
SELECT tabname, tabid, partnum, HEX(partnum) hex_tblspace_name FROM systables
```

If the output includes a row with a table name but a **partnum** of 0, this table consists of two or more table fragments, each located in its own tbspace. For example, Figure 4-5 shows a table called **account** that has **partnum** 0.

tablename	tabid	partnum	hex_tbspace_name
sysfragments	25	1048611	0x00100023
branch	100	1048612	0x00100024
teller	101	1048613	0x00100025
account	102	0	0x00000000
history	103	1048615	0x00100027
results	104	1048616	0x00100028

Figure 4-5. Output from *sysables Query with partnum Values*

To obtain the actual tbspace numbers for the fragments that make up the table, you must query the **sysfragments** table for the same database. Figure 4-6 shows that the **account** table from Figure 4-5 has three table fragments and three index fragments.

tabid	fragtype	partn	hex_tbspace_name
102	T	1048614	0x00100026
102	T	2097154	0x00200002
102	T	3145730	0x00300002
102	I	1048617	0x00100029
102	I	2097155	0x00200003
102	I	3145731	0x00300003

Figure 4-6. Output from *sysfragments Table with partn Values*

Tbspace Number Elements

The first page in a tbspace is logical page 0. (Physical page numbers refer to the address of the page in the chunk.) The root space tbspace **tbspace** is always contained in the first dbspace and on logical page 1 within the tbspace **tbspace**. (The bitmap page is page 0.)

Tbspace Tbspace Size

These tbspace **tbspace** pages are allocated as an extent when the dbspace is initialized. If the database server attempts to create a table, but the tbspace **tbspace** is full, the database server allocates a next extent to the tbspace.

When a table is removed from the dbspace, its corresponding entry in the tbspace **tbspace** is deleted.

Tbspace Tbspace Bitmap Page

The first page of the tbspace **tbspace**, like the first page of any initial extent, is a bitmap that describes the page fullness of the following pages. Each page that follows has an entry on the bitmap page. If needed, additional bitmap pages are located throughout the contiguous space allocated for the tbspace, arranged so that each bitmap describes only the pages that follow it, until the next bitmap or the end of the dbspace. Bitmap pages fall at distinct intervals within tbspaces pages. Each bitmap page describes a fixed number of pages that follow it.

Structure of the Database Tblspace

The database tblspace appears only in the initial chunk of the root dbspace. The database tblspace contains one entry for each database managed by the database server. Figure 4-7 illustrates the location of the database tblspace.

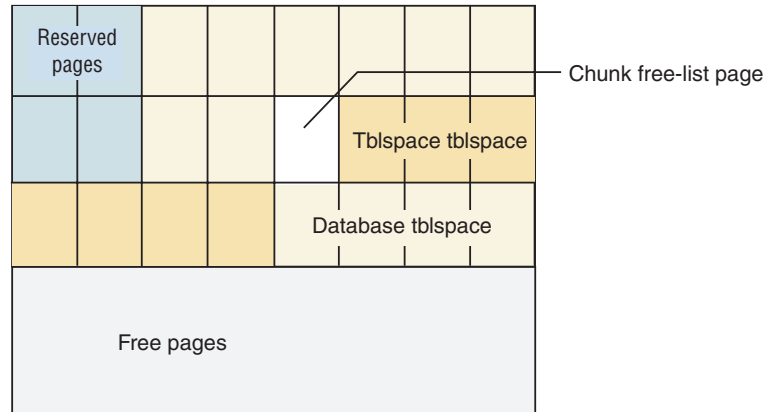

Figure 4-7. Database Tblspace Location in Initial Chunk of Root Dbspace

Database Tblspace Number

The tblspace number of the database tblspace is always 0x100002. This tblspace number appears in an `onstat -t` listing if the database tblspace is active.

Database Tblspace Entries

Each database tblspace entry includes the following five components:

- Database name
- Database owner
- Date and time that the database was created
- The tblspace number of the `systables` system catalog table for this database
- Flags that indicate logging mode

The database tblspace includes a unique index on the database name to ensure that every database is uniquely named. For any database, the `systables` table describes each permanent table in the database. Therefore, the database tblspace only points to the detailed database information located elsewhere.

When the root dbspace is initialized, the database tblspace first extent is allocated. The initial-extent size and the next-extent size for the database tblspace are four pages. You cannot modify these values.

Structure and Allocation of an Extent

This section covers the following topics:

- Extent structure
- Next-extent allocation

Extent Structure

An extent is a collection of contiguous pages within a dbspace. Every permanent database table has two extent sizes associated with it. The initial-extent size is the

number of kilobytes allocated to the table when it is first created. The next-extent size is the number of kilobytes allocated to the table when the initial extent, and every extent thereafter, becomes full.

Blobspaces do not use extents.

For specific instructions on how to specify and calculate the size of an extent, see your *IBM Informix Performance Guide*.

Extent size:

The default size for first and next extents is 16 kilobytes. If this transforms to fewer than 4 pages in a particular dbspace, the database server uses the minimum extent size of 4 pages. If a dbspace has a size of 8 kilobytes, which transforms to 2 pages, the database server increases the extent size to 32 kilobytes.

The maximum size of an extent is 2^{31} pages, equivalent to the maximum chunk size.

If the chunk is smaller than the maximum size, the maximum extent size depends on the contiguous space available in the chunk.

Tbspaces that hold *index fragments* follow different rules for extent size. The database server bases the extent size for these tablespaces on the extent size for the corresponding table fragment. The database server uses the ratio of the row size to index key size to assign an appropriate extent size for the index tablespace (see the sections on estimating index page size and fragmenting table indexes in the *IBM Informix Performance Guide*).

The maximum number of extents for a partition is 32767.

Page Types Within a Table Extent:

Within the extent, individual pages contain different types of data. Extent pages for a table can be separated into the following categories:

- Data pages
Data pages contain the data rows for the table.
- Bitmap pages
Bitmap pages contain control information that monitors the fullness of every page in the extent.
- Blobpages
Blobpages contain TEXT and BYTE data that is stored with the data rows in the dbspace. TEXT and BYTE data that resides in a blobspace is stored in blobpages, a structure that is completely different than the structure of a dbspace blobpage.
- Free pages
Free pages are pages in the extent that are allocated for tablespace use, but whose function has not yet been defined. Free pages can be used to store any kind of information: data, including TEXT or BYTE data types; index; or bitmap.

Figure 4-8 on page 4-9 illustrates the possible structure of a nonfragmented table with an initial-extent size of 8 pages and a next-extent size of 16 pages.

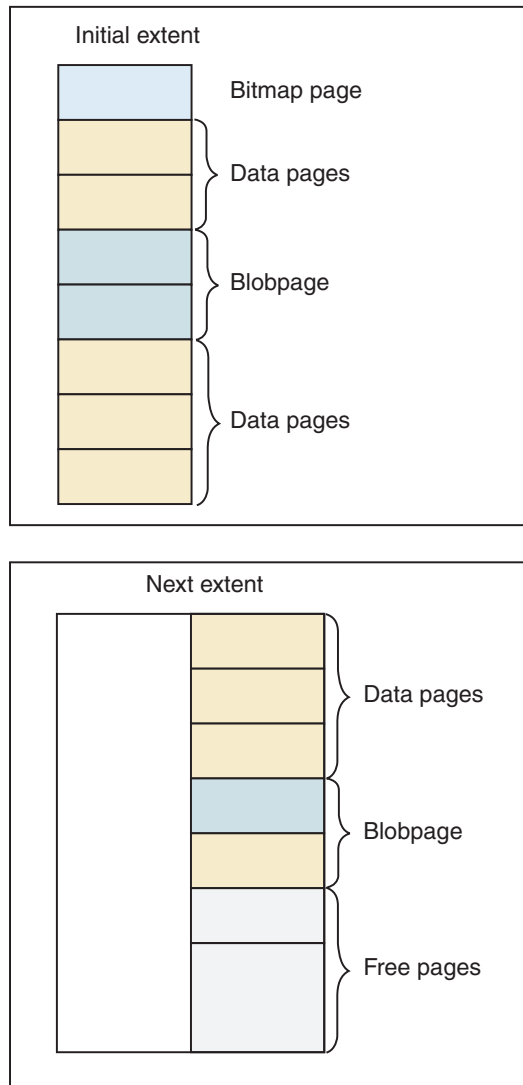

Figure 4-8. Extent Structure of a Table

Page Types Within an Index Extent:

The database server stores index pages into different tablespaces than the table with which it is associated. Within the extent, individual index pages contain different types of data. Index pages can be separated into the following categories:

- Index pages (root, branch, and leaf pages)
Index pages contain the index information for the table.
- Bitmap pages
Bitmap pages contain control information that monitors the fullness of every page in the extent.
- Free pages
Free pages are pages in the extent that are allocated for tablespace use, but whose function has not yet been defined. Free pages can be used to store any kind of information: data, index, TEXT or BYTE data, or bitmap.

All indexes are detached unless you explicitly specify attached indexes.

Important: An extent that is allocated for a table fragment does not contain index pages. Index pages for a fragmented table always reside in a separate tblspace. For more information, see fragmenting table indexes in the chapter on table fragmentation and PDQ in the *IBM Informix Administrator's Guide*.

Figure 4-9 illustrates the extent structure of an index.

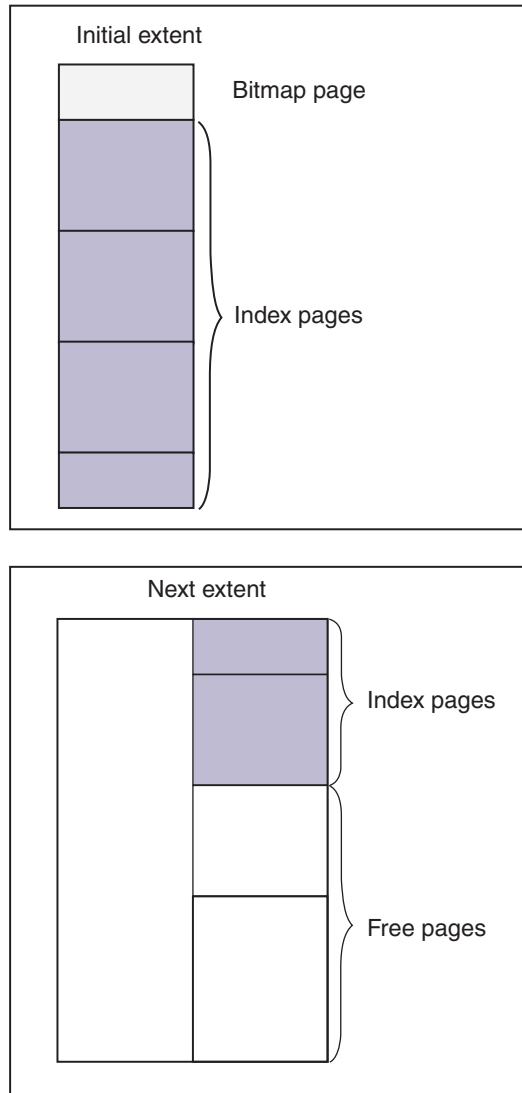

Figure 4-9. Extent Structure of an Index

Next-Extent Allocation

After the initial extent fills, the database server attempts to allocate another extent of contiguous disk space. The procedure that the database server follows is referred to as next-extent allocation.

Extents for a tblspace are tracked as one component of the tblspace **tblspace** information for the table. The maximum number of extents allocated for any tblspace is application and machine dependent because it varies with the amount of space available on the tblspace **tblspace** entry.

Next-Extent Size:

The number of kilobytes that the database server allocates for a next extent is, in general, equal to the size of a next extent, as specified in the SQL statement CREATE TABLE. However, the actual size of the next-extent allocation might deviate from the specified size because the allocation procedure takes into account the following three factors:

- Number of existing extents for this tblspace
- Availability of contiguous space in the chunk and dbspace
- Location of existing tblspace extents

The effect of each of these factors on next-extent allocation is explained in the paragraphs that follow and in Figure 4-10 on page 4-12.

Extent size doubling:

For permanent tables or user-defined temporary tables, the size of the next extent for every allocation is automatically doubled. The size doubles up to 128 kilobytes (KB). For example, if you create a table with the NEXT SIZE equal to 15 KB, the database server allocates the first extent at a size of 15 KB. The next extent is allocated at 30 KB, and the extent after that is allocated at 60 KB. When the extent size reaches 128 KB, the size is doubled only when the remaining space in the table is less than 10% of the total allocated space in the table.

For system-created temporary tables, the next-extent size begins to double after 4 extents have been added.

Lack of Contiguous Space:

If the database server cannot find available contiguous space in the first chunk equal to the size specified for the next extent, it extends the search to the next chunk in the dbspace. Extents are not allowed to span chunks.

If the database server cannot find adequate contiguous space anywhere in the dbspace, it allocates to the table the largest available amount of contiguous space. (The minimum allocation is four pages. The default value is eight pages.) No error message is returned if an allocation is possible, even when the amount of space allocated is less than the requested amount.

Merge of Extents for the Same Table:

If the disk space allocated for a next extent is physically contiguous with disk space already allocated to the same table, the database server allocates the disk space but does not consider the new allocation as a separate extent. Instead, the database server extends the size of the existing contiguous extent. Thereafter, all disk-space reports reflect the allocation as an extension of the existing extent. That is, the number of extents reported is always the number of physically distinct extents, not the number of times a next extent has been allocated plus one (the initial extent). Figure 4-10 on page 4-12 illustrates extent-allocation strategies.

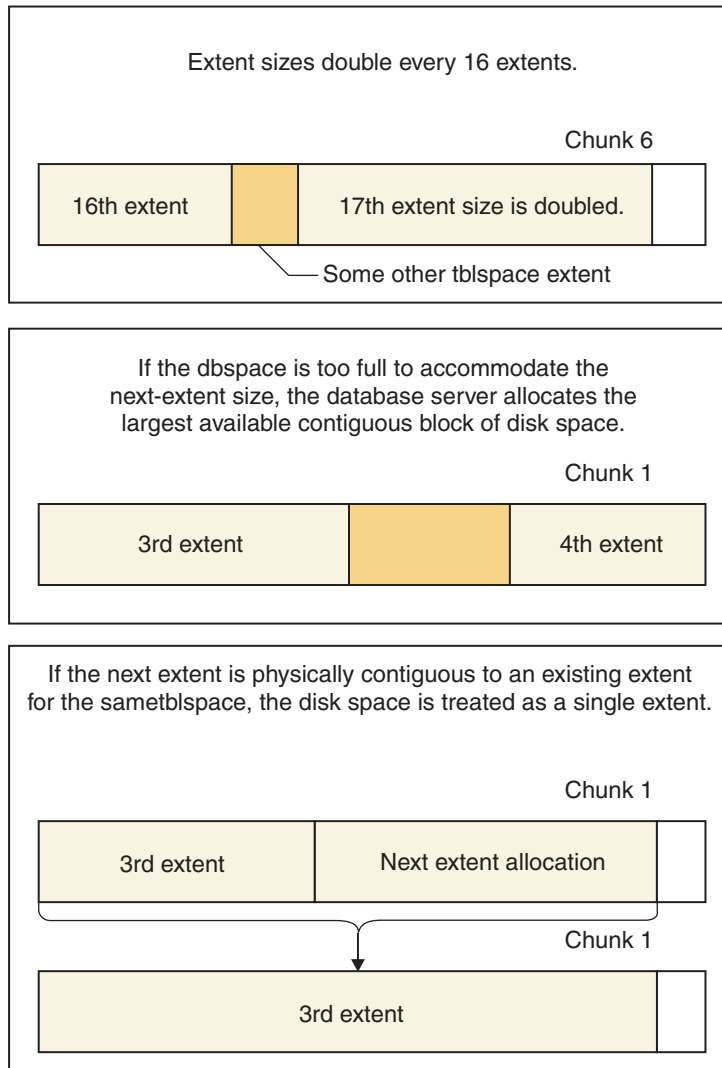

Figure 4-10. Next-Extent Allocation Strategies

After disk space is allocated to a tblspace as part of an extent, the space remains dedicated to that tblspace even if the data contained in it is deleted. For alternative methods of reclaiming this empty disk space, see your *IBM Informix Performance Guide*.

Structure and Storage of a Dbospace Page

The basic unit of database server I/O is a page. Page size might vary among computers.

In Informix, the page size depends on the operating system.

Rows in Nonfragmented Tables

The database server can store rows that are longer than a page. The database server also supports the VARCHAR data type, which results in rows of varying length. As a result, rows do not conform to a single format.

Rows within a table are not necessarily the same length if the table contains one or more columns of type VARCHAR. In addition, the length of a row in such a table might change when an end user modifies data contained in the VARCHAR column.

The length of a row can be greater than a page.

TEXT and BYTE data is not stored within the data row. Instead, the data row contains a 56-byte descriptor that points to the location of the data. The descriptor can point to a dbspace page.

The descriptor can point to a blobpage. If you are using the Optical Subsystem, the descriptor can also point to an optical-storage subsystem.

For instructions about how to estimate the length of fixed-length and variable-length data rows, see your *IBM Informix Performance Guide*.

Definition of Rowid: Informix uses two different types of rowids to identify data in tables:

- *Serial rowid*

These rowids are fields in a table and are assigned to tables created with the WITH ROWID option.

- *Internal rowid*

The database server identifies each data row in a table with a unique internal rowid. This rowid identifies the location of the row within the dbspace.

To obtain the internal rowids for a table, use the **oncheck -pD** option. For more information, see “**oncheck -cd** and **oncheck -cD** commands: Check pages” on page 9-8.

In a nonfragmented table, the term *rowid* refers to a unique 4-byte integer that defines the physical location of the row in the table. The page that contains the first byte of the data row is the page that is specified by the rowid. This page is called the data row *home page*.

Fragmented tables can also have rowids, but they are implemented in a different way. For more information on this topic, see “Rows in Fragmented Tables.”

Use of Rowids: Every data row in a nonfragmented table is uniquely identified by an unchanging rowid. When you create an index for a nonfragmented table, the rowid is stored in the index pages associated with the table to which the data row belongs. When the database server requires a data row, it searches the index to find the key value and uses the corresponding rowid to locate the requested row. If the table is not indexed, the database server might sequentially read all the rows in the table.

Eventually, a row might outgrow its original storage location. If this occurs, a *forward pointer* to the new location of the data row is left at the position defined by the rowid. The forward pointer is itself a rowid that defines the page and the location on the page where the data row is now stored.

Rows in Fragmented Tables

Unlike rows in a nonfragmented table, the database server does *not* assign a rowid to rows in fragmented tables. If you want to access data by rowid, you must explicitly create a rowid column as described in your *IBM Informix Performance*

Guide. If user applications attempt to reference a rowid in a fragmented table that does not contain a rowid that you explicitly created, the database server returns an appropriate error code to the application.

Access to Data in Fragmented Tables with Rowid: From the viewpoint of an application, the functionality of a rowid column in a fragmented table is identical to the rowid of a nonfragmented table. However, unlike the rowid of a nonfragmented table, the database server uses an index to map the rowid to a physical location.

When the database server accesses a row in a fragmented table using the rowid column, it uses this index to look up the physical address of the row before it attempts to access the row. For a nonfragmented table, the database server uses direct physical access without an index lookup. As a consequence, accessing a row in a fragmented table using rowid takes slightly longer than accessing a row using rowid in a nonfragmented table. You should also expect a small performance impact on the processing of inserts and deletes due to the cost of maintaining the rowid index for fragmented tables.

Primary-key access can lead to significantly improved performance in many situations, particularly when access is in parallel.

Recommendations on Use of Rowid

It is recommended that application developers use primary keys as a method of access rather than rowids. Because primary keys are defined in the ANSI specification of SQL, using them to access data makes your applications more portable.

For a complete description on how to define and use primary keys to access data, see the *IBM Informix Guide to SQL: Reference* and the *IBM Informix Guide to SQL: Tutorial*.

Data-Row Format and Storage

The variable length of a data row has the following consequences for row storage:

- A page might contain one or more whole rows.
- A page might contain portions of one or more rows.
- A page might contain a combination of whole rows and partial rows.
- An updated row might increase in size and become too long to return to its original storage location in a row.

The following paragraphs describe the guidelines that the database server follows during data storage.

Storage of Row:

To minimize retrieval time, rows are not broken across page boundaries unnecessarily. Rows that are shorter than a page are always stored as whole rows. A page is considered *full* when the count of free bytes is less than the number of bytes needed to store a row of maximum size.

Location of Rows:

When the database server receives a row that is longer than a page, the row is stored in as many whole pages as required. The database server then stores the trailing portion in less than a full page.

The page that contains the first byte of the row is the row home page. The number of the home page becomes the logical page number contained in the rowid. Each full page that follows the home page is referred to as a big-remainder page. If the trailing portion of the row is less than a full page, it is stored on a remainder page.

After the database server creates a remainder page to accommodate a long row, it can use the remaining space in this page to store other rows.

Figure 4-11 illustrates the concepts of home page, big-remainder page, and remainder page.

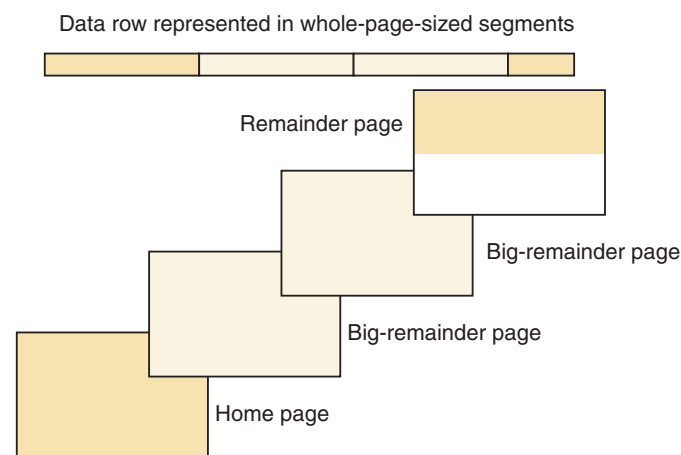

Figure 4-11. Remainder Pages

Page Compression:

Over time, the free space on a page can become fragmented. When the database server attempts to store data, it first checks row length against the number of free bytes on a page to determine if the row fits. If adequate space is available, the database server checks if the page contains adequate contiguous free space to hold the row (or row portion). If the free space is not contiguous, the database server calls for page compression.

Structure of Fragmented Tables

Although table fragmentation is transparent to applications, as database server administrator you should be aware of how the database server allocates disk space for table fragments and how the database server identifies rows in those fragments.

Each table fragment has its own `tblspace` with a unique `tblspace_id` or `fragment_id`. Figure 4-12 on page 4-16 shows the disk allocation for a fragmented table that resides in named fragments of the same `dbspace`.

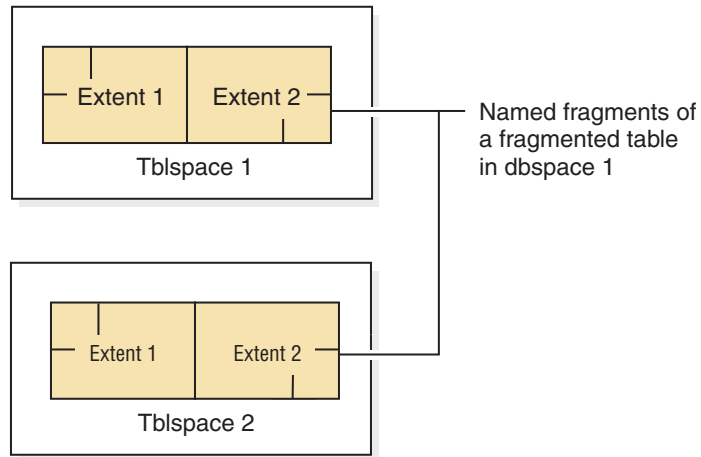

Figure 4-12. Disk Structures for a Fragmented Table

Attached Indexes

With an attached index, the index and data are fragmented in the same way. You can decide whether to store the index pages with the corresponding data pages in the same dbspace or store them in separate dbspaces. For information on choosing a fragmentation strategy, see the *IBM Informix Performance Guide*.

Detached Indexes

For detached indexes, the table fragment and index fragment are stored in tablespaces in separate dbspaces.

Structure of B-Tree Index Pages

This section provides general information about the structure of B-tree index pages. It is designed as an overview for the interested reader. For more information on B-tree indexes, see your *IBM Informix Performance Guide*.

Definition of B-tree terms

The database server uses a B-tree structure to organize index information.

Figure 4-13 on page 4-17 shows that a fully developed B-tree index is composed of the following three different types of index pages or nodes:

- One *root node*
A root node contains node pointers to branch nodes.
- Two or more *branch nodes*
A branch node contains pointers to leaf nodes or other branch nodes.
- Many *leaf nodes*
A leaf node contains index items and horizontal pointers to other leaf nodes.

Each node serves a different function. The following sections describe each node and the role that it plays in indexing.

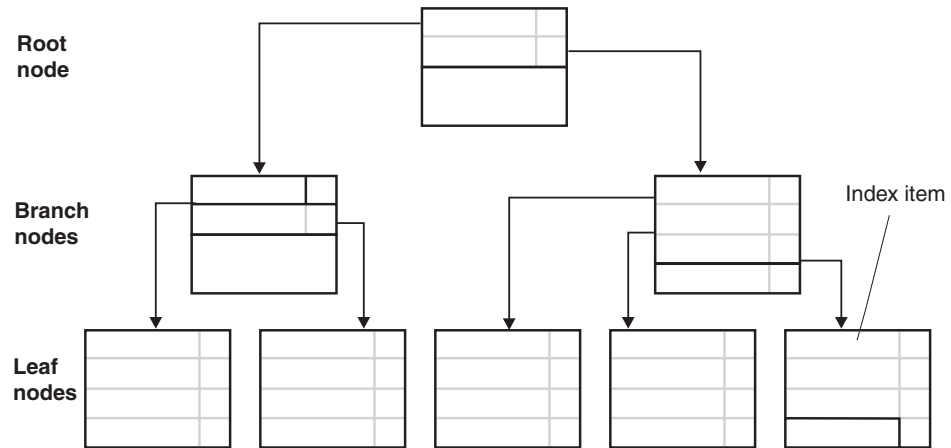

Figure 4-13. Full B-Tree Structure

Index items

The fundamental unit of an index is the *index item*. An index item contains a key value that represents the value of the indexed column for a particular row. An index item also contains rowid information that the database server uses to locate the row in a data page.

Index nodes

A node is an index page that stores a group of index items.

Forest of trees indexes as alternatives to traditional B-Tree indexes

Unlike a traditional B-tree index, a forest of trees index is a large B-tree index that is divided into smaller subtrees with multiple root nodes and fewer levels. You can create a forest of trees index as an alternative to a B-tree index when you want to alleviate root node contention and allow more concurrent users to access the index without waiting.

Related concepts:

[➡ Forest of trees indexes \(Performance Guide\)](#)

Logical Storage of Indexes

This section presents an overview of how the database server creates and fills an index.

Creation of Root and Leaf Nodes: When you create an index for an empty table, the database server allocates a single index page. This page represents the root node and remains empty until you insert data in the table.

At first, the root node functions in the same way as a leaf node. For each row that you insert into the table, the database server creates and inserts an index item in the root node. Figure 4-14 on page 4-18 illustrates how a root node appears before it fills.

Root node 1	
Albertson	rowid information
Baxter	rowid information
Beatty	rowid information
Currie	rowid information
Keyes	rowid information
Lawson	rowid information
Mueller	rowid information

Figure 4-14. Root Node

When the root node becomes full of index items, the database server splits the root node by performing the following steps:

- Creates two leaf nodes
- Moves approximately half of the root-node entries to each of the newly created leaf nodes
- Puts pointers to leaf nodes in the root node

As you add new rows to a table, the database server adds index items to the leaf nodes. When a leaf node fills, the database server creates a new leaf node, moves part of the contents of the full index node to the new node, and adds a node pointer to the new leaf node in the root node.

For example, suppose that leaf node 3 in Figure 4-15 becomes full. When this situation occurs, the database server adds yet another leaf node. The database server moves part of the records from leaf node 3 to the new leaf node, as Figure 4-15 shows.

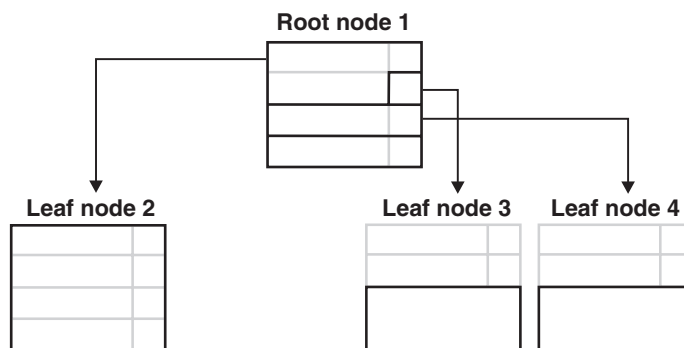

Figure 4-15. Leaf Node 4 Created After Leaf Node 3 Fills

Creation of branch nodes: Eventually, as you add rows to the table, the database server fills the root node with node pointers to all the existing leaf nodes. When the database server splits yet another leaf node, and the root node has no room for an additional node pointer, the following process occurs.

The database server splits the root node and divides its contents among two newly created branch nodes. As index items are added, more and more leaf nodes are split, causing the database server to add more branch nodes. Eventually, the root node fills with pointers to these branch nodes. When this situation occurs, the database server splits the root node again. The database server then creates yet another branch level between the root node and the lower branch level. This

process results in a four-level tree, with one root node, two branch levels, and one leaf level. The B-tree structure can continue to grow in this way to a maximum of 20 levels.

Branch nodes can point either to other branch nodes below them (for large indexes of four levels or more) or to leaf nodes. In Figure 4-16, the branch node points to leaf nodes only. The first item in the left branch node contains the same key value as the largest item in the leftmost leaf node and a node pointer to it. The second item contains the largest item in the next leaf node and a node pointer to it. The third item in the branch node contains only a pointer to the next higher leaf node. Depending on the index growth, this third item can contain the actual key value in addition to the pointer at a later point during the life span of the index.

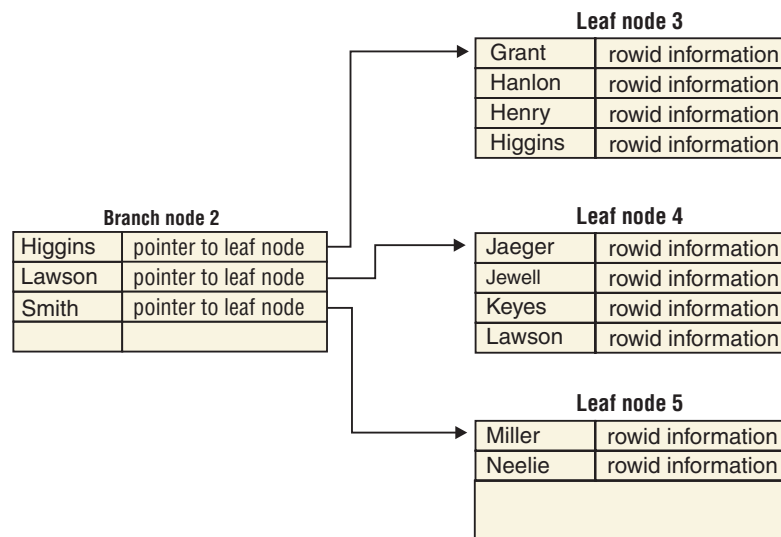

Figure 4-16. Typical Contents of a Branch Node

Duplicate Key Values: Duplicate key values occur when the value of an indexed column is identical for multiple rows. For example, suppose that the third and fourth leaf nodes of a B-tree structure contain the key value Smith. Suppose further that this value is duplicated six times, as Figure 4-17 illustrates.

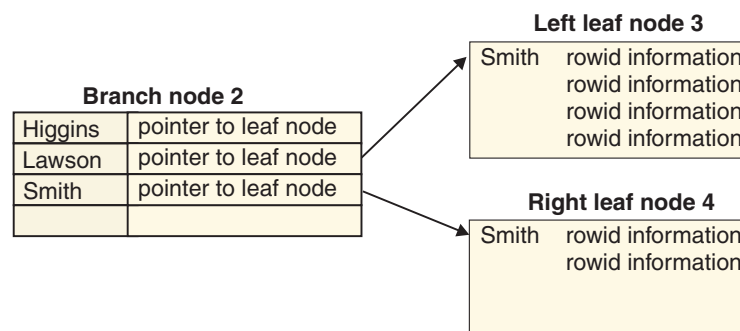

Figure 4-17. Leaf Nodes 3 and 4

The first item on the third leaf page contains the duplicate key value, Smith, and the rowid information for the first physical row in the table that contains the duplicate key value. To conserve space, the second item does not repeat the key

value Smith but instead contains just the rowid information. This process continues throughout the page; no other key values are on the leaf, only rowid information.

The first item on the fourth leaf page again contains the duplicated key value and rowid information. Subsequent items contain only rowid information.

Now consider the branch node. The third item in the branch node contains the same key value and rowid as the largest item in the third leaf node and a node pointer to it. The fourth item would contain only a node pointer to the fourth leaf node, thus saving the space of an additional duplicate key value.

Key-Value Locking: To increase concurrency, the database server supports *key-value* locking in the B-tree index. Key-value locking locks only the value of the key instead of the physical location in the B-tree index.

One of the most important uses for key-value locking is to assure that a unique key remains unique through the end of the transaction that deleted it. Without this protection mechanism, user A might delete a unique key within a transaction, and user B might insert a row with the same key before the transaction commits. This scenario makes rollback by user A impossible. Key-value locking prevents user B from inserting the row until the end of user A's transaction.

Adjacent Key Locking: With Repeatable Read isolation level, the database server is required to protect the *read set*. The read set consists of the rows that meet the filters in the WHERE clause of the query. To guarantee that the rows do not change, the database server obtains a lock on the index item that is adjacent to the right-most item of the read set.

Freed Index Pages: When the database server physically removes an index item from a node and frees an index page, the freed page is reused.

Filling Indexes: When you create an index, you can specify how densely or sparsely filled you want the index. The index fill factor is a percentage of each index page that will be filled during the index build. Use the FILLFACTOR option of the CREATE INDEX statement or the FILLFACTOR configuration parameter to set the fill factor. This option is particularly useful for indexes that you do not expect to grow after they are built. For additional information about the FILLFACTOR option of the CREATE INDEX statement, see the *IBM Informix Guide to SQL: Syntax*.

Calculating the Length of Index Items: For data types other than VARCHAR, the length of an index item is calculated by adding the length of the key value plus 5 bytes for each rowid information associated with the key value.

The key values in an index are typically of fixed length. If an index holds the value of one or more columns of the VARCHAR data type, the length of the key value is at least the sum of the length-plus-one of each VARCHAR value in the key.

In Informix, the maximum length of a key value is 390 bytes. The combined size of VARCHAR columns that make up a key must be less than 390, minus an additional byte for each VARCHAR column. For example, the key length of the index that the database server builds for the following statements equals 390, or ((255+1) + (133+1)):

```
CREATE TABLE T1 (c1 varchar(255, 10), c2 varchar(133, 10));
CREATE INDEX I1 on T1(c1, c2);
```

Functional Indexes

A *functional index* is one in which all keys derive from the results of a function. If you have a column of pictures, for example, and a function to identify the predominant color, you can create an index on the result of the function. Such an index would enable you to quickly retrieve all pictures having the same predominant color, without re-executing the function.

A functional index uses the same B-tree structure as any other B-tree index. The only difference is that the determining function is applied during an insert or an update whenever the column that is the argument to the function changes. For more information on the nature of functional indexes, refer to your *IBM Informix Performance Guide*.

To create a functional index, use the CREATE FUNCTION and CREATE INDEX statements. For more information on these statements, refer to the *IBM Informix Guide to SQL: Syntax*.

Structure of R-Tree Index Pages

An index structure that relies on one-dimensional ordering of key values does not work for spatial data; for example, two dimensional geometric shapes such as circles, squares, and triangles. Efficient retrieval of spatial data, such as the data used in geographic information systems (GIS) and computer-aided design (CAD) applications, requires an access method that handles multidimensional data. The database server implements an R-tree index to access spatial data efficiently. For information about the structure of index pages, refer to the *IBM Informix R-Tree Index User's Guide*.

Storage of Simple Large Objects

This section explains the structures and storage techniques that the database server uses to store simple large objects (TEXT or BYTE data).

Structure of a BlobSpace

When you create a blobSpace, you can specify the effective size of the data pages, which are called blobpages. The blobpage size for the blobSpace is specified when the blobSpace is created. Blobpage size must be a multiple of page size. (For information on determining database server page size, see the chapter on managing disk space in the *IBM Informix Administrator's Guide*.) All blobpages within a blobSpace are the same size, but the size of the blobpage can vary between blobSpaces. Blobpage size can be greater than the page size because data stored in a blobSpace is never written to the page-sized buffers in shared memory.

The advantage of customizing the blobpage size is storage efficiency. Within a blobSpace, TEXT and BYTE data is stored in one or more blobpages, but simple large objects do not share blobpages. Storage is most efficient when the TEXT or BYTE data is equal to or slightly smaller than the blobpage size.

The blobSpace free-map pages and bitmap pages are the size specified as a database server page, which enables them to be read into shared memory and to be logged.

When the blobSpace is first created, it contains the following structures:

- BlobSpace free-map pages
- The blobSpace bitmap that tracks the free-map pages

- Unused blobpages

Structure of a Dbspace Blobpage

TEXT or BYTE data that is stored in the dbspace is stored in a blobpage. The structure of a dbspace blobpage is similar to the structure of a dbspace data page. The only difference is an extra 12 bytes that can be stored along with the TEXT or BYTE data in the data area.

Simple large objects can share dbspace blobpages if more than one simple large object can fit on a single page, or if more than one trailing portion of a simple large object can fit on a single page.

For a discussion of how to estimate the number of dbspace blobpages needed for a specific table, see your *IBM Informix Performance Guide*.

Each segment of TEXT or BYTE data stored in a dbspace page might be preceded by up to 12 bytes of information that does not appear on any other dbspace page. These extra bytes are overhead.

Simple-Large-Object Storage and the Descriptor

Data rows that include TEXT or BYTE data do not include the data in the row itself. Instead, the data row contains a 56-byte descriptor with a forward pointer (rowid) to the location where the first segment of data is stored.

The descriptor can point to one of the following items:

- A page (if the data is stored in a dbspace)
- A blobpage (if the data is stored in a blobpage)
- An optical platter (if you are using the Optical Subsystem)

Creation of Simple Large Objects

When a row that contains TEXT or BYTE data is to be inserted, the simple large objects are created first. After the simple large objects are written to disk (or optical medium), the row is updated with the descriptor and inserted.

Deletion or Insertion of Simple Large Objects

The database server cannot modify simple large objects. It can only insert or delete them. Deleting a simple large object means that the database server frees the space consumed by the deleted object for reuse.

When TEXT or BYTE data is updated, a new simple large object is created, and the data row is updated with the new blob descriptor. The old image of the row contains the descriptor that points to the obsolete value for the simple large object. The space consumed by the obsolete simple large object is freed for reuse after the update is committed. Simple large objects are automatically deleted if the rows that contain their blob descriptors are deleted. (Blobpages that stored a deleted simple large object are not available for reuse until the logical log that contains the original INSERT record for the deleted simple large object is backed up. For more information, see backing up logical-log files to free blobpages in the chapter on what is the logical log in the *IBM Informix Administrator's Guide*.)

Size Limits for Simple Large Objects

The largest simple large object that the blob descriptor can accommodate is $(2^{31} - 1)$, or about 2 gigabytes.

Blobspace Page Types

Every blobspace chunk contains three types of pages:

- A blobspace free-map page
- A bitmap page
- Blobpages

Blobspace Free-Map Page

The blobspace free-map page identifies unused blobpages so that the database server can allocate them as part of simple-large-object creation. When a blobpage is allocated, the free-map entry for that page is updated. All entries for a single simple large object are linked.

A blobspace free-map page is the size of one database server page. Each entry on a free-map page is 8 bytes, stored as two 32-bit words, as follows:

- The first bit in the first word specifies whether the blobpage is free or used.
- The next 31 bits in the first word identify the logical-log file that was current when this blobpage was written. (This information is needed for logging TEXT or BYTE data.)
- The second word contains the blobspace number associated with the simple large object stored on this page.

The number of entries that can fit on a free-map page depends on the page size of your computer. The number of free-map pages in a blobspace chunk depends on the number of blobpages in the chunk.

Blobspace Bitmap Page

The blobspace bitmap page tracks the fullness and number of blobspace free-map pages in the chunk. Each blobspace bitmap page is capable of tracking a quantity of free-map pages. The size of the blobspace bitmap page depends on the size of the system page. If the system page is 2K, the blobspace bitmap page can track 2,032,128 blobpages. If the system page is 4K, the blobspace bitmap page can track 8,258,048 blobpages.

Blobpage

The blobpage contains the TEXT or BYTE data. Blobpage size is specified by the database server administrator who creates the blobspace. Blobpage size is specified as a multiple of the page size.

Structure of a Blobspace Blobpage

The storage strategy used to store simple large objects in a blobspace differs from the dbspace storage strategy. The database server does not combine whole simple large objects or portions of a simple large object on a single blobspace blobpage.

For example, if blobpage blobpages are 24 kilobytes each, a simple large object that is 26 kilobytes is stored on two 24-kilobyte pages. The extra 22 kilobytes of space remains unused.

The structure of a blobpage includes a blobpage header, the TEXT or BYTE data, and a page-ending time stamp. The blobpage header includes, among other information, the page-header time stamp and the blob time stamp associated with the forward pointer in the data row. If a simple large object is stored on more than one blobpage, a forward pointer to the next blobpage and another blob time stamp are also included in the blobpage header.

Sbospace Structure

An sbospace is similar to a blobspace except that it holds smart large objects.

When an sbospace is created in a database, it contains an sbospace descriptor. Each sbospace chunk contains the following structures:

- Sbospace chunk descriptors
- Chunk free-page list
- An sbospace metadata area (up to one for each chunk)
- Reserved data areas (up to two for each chunk)
- User-data areas (up to two for each chunk)

For best performance, it is recommended that the metadata area be located in the middle of the sbospace. The database server automatically places the metadata area in the correct location. However, to specify the location of the metadata area, specify the **-Mo** flag in the **onspaces** command.

If you do not specify the size of the metadata area in the **-Ms** flag of the **onspaces** command, the database server uses the value of `AVG_LO_SIZE` (defaults to 8 kilobytes) to calculate the size of the metadata area. For more information, see “Creating an Sbospace with the **-Df** option” on page 20-13.

Normally, you can let the system calculate the metadata size for you. If you want to estimate the size of the metadata area, see the chapter on table performance considerations in the *IBM Informix Performance Guide*.

Figure 4-18 on page 4-25 illustrates the chunk structure of an sbospace as it appears immediately after the sbospace is created. Each reserved area can be allocated to either the user-data or metadata area. Reserved areas are always within the user-data area of the chunk.

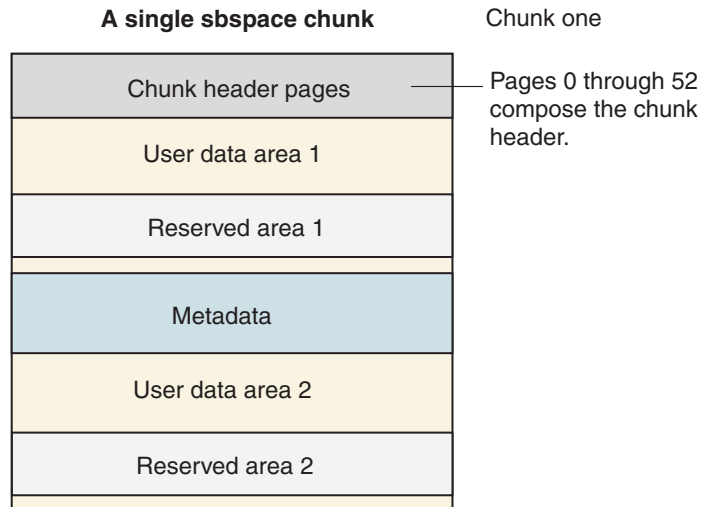

Figure 4-18. A Single Sbospace Chunk

Because the chunk in Figure 4-18 is the first in the sbospace, it contains an sbospace descriptor. The chunk descriptor `tblspace` in **chunk one** contains information about chunk one and all chunks added to the sbospace thereafter.

Structure of the metadata area

An sbospace contains a metadata area for each chunk in the sbospace.

As with the chunk header pages, four areas are exclusive to the first chunk in a sbospace: the sbospace descriptor `tblspace`, the chunk adjunct `tblspace`, and the level-1 and level-2 archive `tblspaces`. The `tblspace` header section contains a `tblspace` header for each of these `tblspaces` (notably excluding the `tblspace tblspace`). Figure 4-19 shows the layout of the metadata in the single-chunk sbospace.

Structure of the metadata area for a single-chunk sbospace

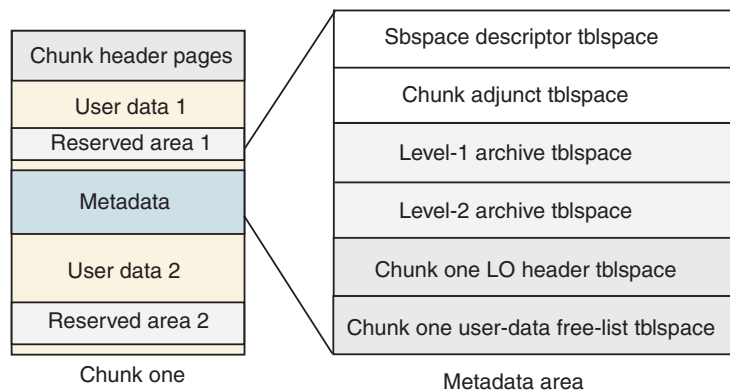

Figure 4-19. Structure of the metadata area for a single-chunk sbospace

When you specify the sbospace name in the `oncheck -ps` option, you can display the number of pages allocated and used for each `tblspace` in the metadata area.

The following items describe how the metadata area grows:

- The sbospace descriptor `tblspace` does not grow.

- The chunk adjunct tblspace grows as chunks are added.
- The LO header tblspace grows as large objects are added to the chunk.
- The tblspace for user-data free list grows if free spaces in the chunk are heavily fragmented.

Sbpage Structure

Each sbpage is composed of three elements: an sbpage header, the actual user data itself, and an sbpage trailer. Figure 4-20 shows the structure of an sbpage. The sbpage header consists of the standard page header. The sbpage trailer is used to detect an incomplete write on the page and to detect page corruption.

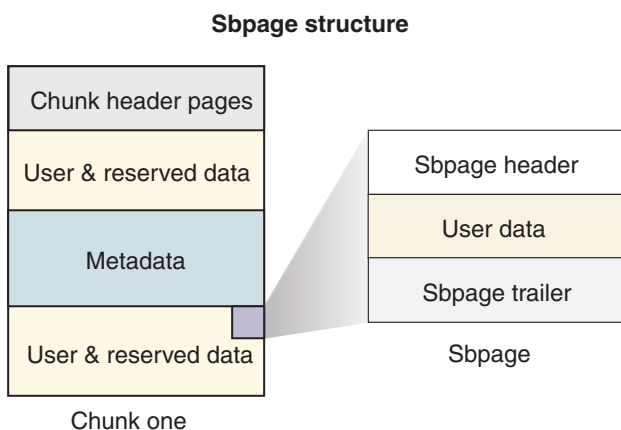

Figure 4-20. Sbpage Structure

Multiple Chunk Sbspace

Figure 4-21 illustrates a possible configuration for a three-chunk sbspace. In this example, **chunk two** contains no metadata of its own. Metadata information for **chunk two** is stored in the metadata area of **chunk one**.

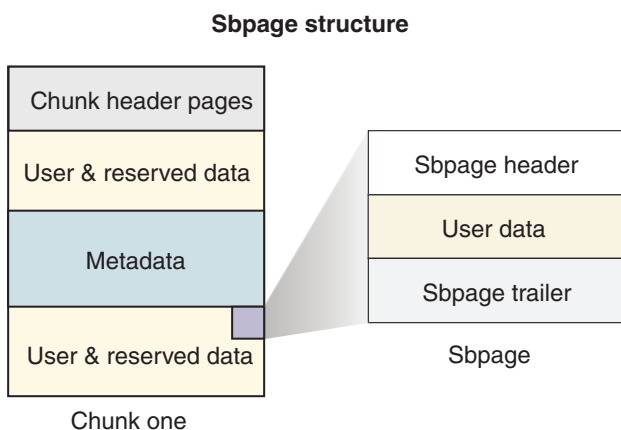

Figure 4-21. Multiple-Chunk Sbspace Structure

The user-data area in **chunk one** of the example is actually optional. **Chunk one** could contain metadata for all other chunks in the sbspace.

Time Stamps

The database server uses a time stamp to identify a time when an event occurred relative to other events of the same kind. The time stamp is not a literal time that refers to a specific hour, minute, or second. It is a 4-byte integer that the database server assigns sequentially.

Database and Table Creation: What Happens on Disk

This section explains how the database server stores data related to the creation of a database or table and allocates the disk structures that are necessary to store your data.

Database Creation

After the root dbspace exists, users can create a database. The paragraphs that follow describe the major events that occur on disk when the database server adds a new database.

Disk-Space Allocation for System Catalog Tables

The database server searches the chunk free-list pages in the dbspace, looking for free space in which to create the system catalog tables. For each system catalog table, in turn, the database server allocates eight contiguous pages, the size of the initial extent of each system catalog table. The tables are created individually and do not necessarily reside next to each other in the dbspace. They can be located in different chunks. As adequate space is found for the initial extent of each table, the pages are allocated, and the associated chunk free-list page is updated.

Tracking of System Catalog Tables

The database server tracks newly created databases in the database tblspace, which resides in the root dbspace. An entry describing the database is added to the database tblspace in the root dbspace. (See “Structure of the Database Tblspace” on page 4-7.) For each system catalog table, the database server adds a one-page entry to the tblspace **tblspace** in the dbspace where the database was built. (See “Structure of the Tblspace Tblspace” on page 4-4.) Figure 4-22 illustrates the relationship between the database tblspace entry and the location of the **systables** system catalog table for the database.

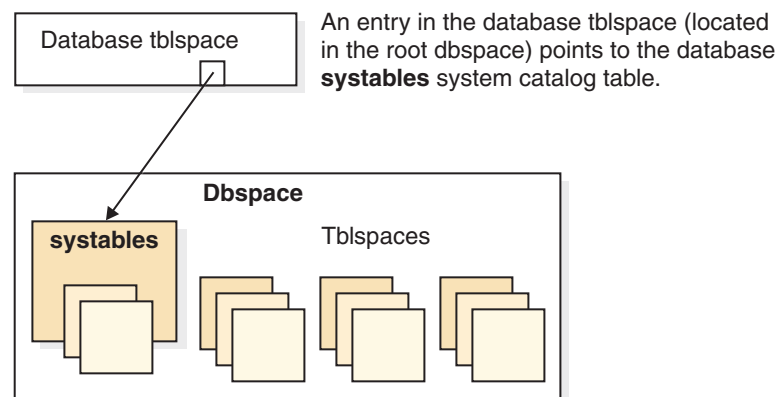

Figure 4-22. New Databases

For instructions on how to list your databases after you create them, see monitoring databases in the chapter on managing database-logging status in the *IBM Informix Administrator's Guide*.

Table Creation

After the root dbspace exists, and a database has been created, users with the necessary SQL privileges can create a database table. When users create a table, the database server allocates disk space for the table in units called extents (see what is an extent in the chapter on where data is stored in the *IBM Informix Administrator's Guide*). The paragraphs that follow describe the major events that occur when the database server creates a table and allocates the initial extent of disk space.

Disk-Space Allocation

The database server searches the chunk free-list pages in the dbspace for contiguous free space equal to the initial extent size for the table. When adequate space is found, the pages are allocated, and the associated chunk free-list page is updated.

If the database server cannot find adequate contiguous space anywhere in the dbspace, it allocates to the table the largest available amount of contiguous space. No error message is returned if an allocation is possible, even when the amount of space allocated is less than the requested amount. If the minimum extent size cannot be allocated, an error is returned. (Extents cannot span two chunks.)

Entry in the Tblspace Tblspace

The database server adds a one-page entry for this table to the tblspace **tblspace** in this dbspace. The tblspace number assigned to this table is derived from the logical page number in the tblspace **tblspace** where the table is described. See "Tblspace Numbers" on page 4-5.

The tblspace number indicates the dbspace where the tblspace is located. Tblspace extents can be located in any of the dbspace chunks.

If you must know exactly where the tblspace extents are located, execute the **oncheck -pe** command for a listing of the dbspace layout by chunk.

Entries in the System Catalog Tables

The table itself is fully described in entries stored in the system catalog tables for the database. Each table is assigned a table identification number or *tabid*. The *tabid* value of the first user-defined table object in a database is always 100. (The object whose *tabid* = 100 might also be a view, synonym, or a sequence.) For a complete discussion of the system catalog, see the *IBM Informix Guide to SQL: Reference*.

A table can be located in a dbspace that is different than the dbspace that contains the database. The tblspace itself is the sum of allocated extents, not a single, contiguous allocation of space. The database server tracks tblspaces independently of the database.

Creation of a Temporary Table

The tasks involved in creating temporary tables are similar to the tasks that the database server performs when it adds a new permanent table. The key difference is that temporary tables do not receive an entry in the system catalog for the database. For more information, see the section defining a temporary table, in the chapter on where data is stored in the *IBM Informix Administrator's Guide*.

Chapter 5. Interpreting Logical-Log Records

In This Chapter

To display the logical-log records that the logical-log files contain, use the **onlog** utility.

This chapter provides the following information:

- Brief guidance on reading logical-log records
- A listing of the different logical-log record types

In general, you do not need to read and interpret your logical-log files. However, **onlog** output is useful in debugging situations. For example, you might want to use **onlog** to track a specific transaction or to see what changes the database server made to a specific tblspace. You can also use **onlog** to investigate the cause of an error that occurs during a rollforward. For more information, see “onlog: Display Logical-Log Contents” on page 14-1.

About Logical-Log Records

Most SQL statements generate multiple logical-log records. Interpreting logical-log records is more complicated when the database server records the following events in the logical log:

- A transaction that drops a table or index
- A transaction that rolls back
- A checkpoint in which transactions are still active
- A distributed transaction

The following sections discuss the logical-log records for these events.

Transactions That Drop a Table or Index

Once the database server drops a table or index from a database, it cannot roll back that drop operation. If a transaction contains a DROP TABLE or DROP INDEX statement, the database server handles this transaction as follows:

1. The database server completes all the other parts of the transaction and writes the relevant logical-log records.
2. The database server writes a BEGCOM record to the logical log and the records associated with the DROP TABLE or DROP INDEX (DINDEX, for example).
3. The database server writes a COMMIT record.

If the transaction is terminated unexpectedly after the database server writes the BEGCOM record to the logical log, the database server rolls *forward* this transaction during recovery because it cannot roll back the drop operation.

Transactions That Are Rolled Back

When a rollback occurs, the database server generates a compensation-log record (CLR) for each record in the logical log that is rolled back. The database server uses the CLRs if a system failure takes place *during a rollback*. The CLRs provide

the database server with information on how far the rollback progressed before the failure occurred. In other words, the database server uses the CLR's to log the rollback.

If a CLR contains the phrase includes next record, the next log record that is printed is included within the CLR log record as the compensating operation. Otherwise, you must assume that the compensating operation is the logical undo of the log record to which the **link** field of the CLR points.

Checkpoints with Active Transactions

If any transactions are active at the time of a checkpoint, checkpoint records include subentries that describe each of the active transactions using the following columns:

- Log begin (decimal format)
- Transaction ID (decimal format)
- Unique log number (decimal format)
- Log position (hexadecimal format)
- User name

Distributed Transactions

When distributed transactions (transactions that span multiple database servers) generate log records, they are slightly different than nondistributed transactions. You might need to read and interpret them to determine the state of the transaction on both database servers if a failure occurs as a transaction was committing.

The following log records are involved in distributed transactions:

- BEGPREP
- ENDTRANS
- HEURTX
- PREPARE
- TABLOCKS

For more information about this type of logical-log record, see the material on two-phase commit and logical-log records in the *IBM Informix Administrator's Guide*.

If you are performing distributed transactions with TP/XA, the database server uses an XAPREPARE record instead of a PREPARE record.

Logical-Log Record Structure

Each logical-log record has *header* information. Depending on the record type, additional columns of information also appear in the output, as explained in "Logical-Log Record Types and Additional Columns" on page 5-3.

Logical-Log Record Header

Table 5-1 on page 5-3 contains sample output to illustrate the header columns that display for a logical-log record.

Table 5-1. Sample Output from onlog

addr	len	type	xid	id	link
2c018	32	BEGIN	6	3	0
2c038	140	HDELETE	6	0	2c018
2c0c4	64	DELITEM	6	0	2c038
2c104	40	DELITEM	6	0	2c0c4
2c12c	72	HDELETE	6	0	2c104
2c174	44	DELITEM	6	0	2c12c
2c1a0	72	HDELETE	6	0	2c174
2c1e8	44	DELITEM	6	0	2c1a0
2c214	64	HDELETE	6	0	2c1e8
2c254	56	DELITEM	6	0	2c214
2c28c	48	DELITEM	6	0	2c254
2c2bc	24	PERASE	6	0	2c28c
2c2d4	20	BEGCOM	6	0	2c2bc
2c2e8	24	ERASE	6	0	2c2d4
2c300	28	CHFREE	6	0	2c2e8
2c31c	24	COMMIT	6	0	2c300

Table 5-2 defines the contents of each header column.

Table 5-2. Definition of onlog Header Columns

Header Field	Contents	Format
addr	Log-record address (log position)	Hexadecimal
len	Record length in bytes	Decimal
type	Record-type name	ASCII
xid	Transaction number	Decimal
id	Logical-log number	Decimal
link	Link to the previous record in the transaction	Hexadecimal

Logical-Log Record Types and Additional Columns

In addition to the six header columns that display for every record, some record types display additional columns of information. The information that appears varies, depending on record type. The following table lists all the record types and their additional columns.

The **Action** column indicates the type of database server action that generated the log entry. The **Additional Columns** and **Format** columns describe what information appears for each record type in addition to the header described in “Logical-Log Record Header” on page 5-2.

Table 5-3. Logical-Log Record Types

Record Type	Action	Additional Columns	Format
ADDCHK	Add chunk.	chunk number	Decimal
		chunk name	ASCII
ADDDBS	Add dbspace.	dbspace name	ASCII
ADDITEM	Add item to index.	tblspace ID	Hexadecimal
		rowid	Hexadecimal
		logical page	Decimal
		key number	Decimal
		key length	Decimal
ADDLOG	Add log.	log number	Decimal
		log size (pages)	Decimal
		pageno	Hexadecimal
ALLOCGENPG	Allocate a generic page.	tblspace ID	Decimal
		rowid	Decimal
		slot flags and length	Decimal
		page version if delete	Decimal
		flags, vimage record	Decimal
		rowid for previous	Decimal
		data	ASCII
ALTERDONE	Alter of fragment complete.	tblspace ID	Hexadecimal
		physical page number previous page	Hexadecimal
		logical page number	Decimal
		version of alter	Decimal
ALTSPCOLSNEW	Changed columns in an alter table.	number of columns	Decimal
		special column list	array
ALTSPCOLSOLD	Changed columns in an alter table.	number of columns	Decimal
		special column list	array
BADIDX	Bad index	tblspace ID	Hexadecimal
BEGCOM	Begin commit.	(None)	(None)
BEGIN	Begin work.	date	Decimal
		time	Decimal
		SID	Decimal
		user	ASCII
BEGPREP	Written by the coordinator database server to record the start of the two-phase commit protocol.	flags	Decimal (Value is 0 in a distributed transaction.)
		number of participants	Decimal
BEGWORK	Begin a transaction.	begin transaction time	Decimal
		user ID	Decimal
		process ID	Decimal

Table 5-3. Logical-Log Record Types (continued)

Record Type	Action	Additional Columns	Format
BFRMAP	Simple-large-object free-map change.	tblspace ID	Hexadecimal
		bpageno	Hexadecimal
		status	USED/FREE
		log ID	Decimal
		prev page	Hexadecimal
BLDCL	Build tblspace.	tblspace ID	Hexadecimal
		fextsize	Decimal
		nextsize	Decimal
		row size	Decimal
		ncolumns	Decimal
		table name	ASCII
BMAPFULL	Bitmap modified to prepare for alter.	tblspace ID	Hexadecimal
		bitmap page num	Decimal
BMAP2TO4	2-bit bitmap altered to two 4-bit bitmaps.	tblspace ID	Hexadecimal
		2-bit bitmap page number	Decimal
		flags	Decimal
BSPADD	Add blobspace.	blobspace name	ASCII
BTCPYBCK	Copy back child key to parent.	tblspace ID	Hexadecimal
		parent logical page	Decimal
		child logical page	Decimal
		slot	Decimal
		rowoff	Decimal
		key number	Decimal
BTMERGE	Merge B-tree nodes.	tblspace ID	Hexadecimal
		parent logical page	Decimal
		left logical page	Decimal
		right logical page	Decimal
		left slot	Decimal
		left rowoff	Decimal
		right slot	Decimal
		right rowoff	Decimal
		key number	Decimal
BTSHUFFL	Shuffle B-tree nodes.	tblspace ID	Hexadecimal
		parent logical page	Decimal
		left logical page	Decimal
		right logical page	Decimal
		left slot	Decimal
		left rowoff	Decimal
		key number	Decimal
		flags	Hexadecimal

Table 5-3. Logical-Log Record Types (continued)

Record Type	Action	Additional Columns	Format
BTSPLIT	Split B-tree node.	tblspace ID	Hexadecimal
		rowid	Hexadecimal
		parent logical page	Decimal
		left logical page	Decimal
		right logical page	Decimal
		infinity logical page	Decimal
		rootleft logical page	Decimal
		midsplit	Decimal
		key number	Decimal
		key length	Decimal
CDINDEX	Create detached index.	database name	ASCII
		owner	ASCII
		table name	ASCII
		index name	ASCII
CDR	<p>Captures the set of table columns modified by an update statement such as a <i>bitvector</i>. This log record allows Enterprise Replication to capture only the changed data to avoid transmitting the unchanged columns to a target site.</p> <p>In the example, the first six columns of the table are unchanged (6 leftmost bits in the bitvector are 0), the seventh and eighth columns have been updated (seventh and eighth bits are 1), and so on. The onlog output displays as many bits of bitvector as fit in a single line of the output. To see the entire bitvector displayed in hexadecimal, use the onlog -l command.</p>	name of CDR record	ASCII
		partition number	Hexadecimal
		bitvector	Binary
<p>Sample onlog output for CDR log record:</p> <pre>adr len type xid id link name partno bitvector 40 36 CDR 14 0 18 UPDCOLS 10009a 000000110100110100</pre>			
CHALLOC	Chunk extent allocation.	pageno	Hexadecimal
		size	Hexadecimal
CHCOMBINE	Chunk extent combine.	pageno	Hexadecimal
CHFREET	Chunk extent free.	pageno	Hexadecimal
		size	Hexadecimal

Table 5-3. Logical-Log Record Types (continued)

Record Type	Action	Additional Columns	Format
CHKADJUP	Update chunk adjunct on disk. The database server writes this record when it moves space from the reserved area to the metadata or user-data area or when the user adds an sbpace chunk.	chunk number	Integer
		ud1_start_page	Integer
		ud1_size	Integer
		md_start_page	Integer
		md_size	Integer
		ud2_start_page	Integer
		ud2_size	Integer
CHPHYLOG	Change physical-log location.	flags	Hexadecimal
		pageno	Hexadecimal
		size in kilobytes	Hexadecimal
CHRESERV	Reserve extent for metadata stealing. This record is written when you add an sbpace chunk.	dbspace name	ASCII
		chunk number	Integer
		page number	Integer
CHSPLIT	Chunk extent split.	length	Integer
		pageno	Hexadecimal
CINDEX	Create index.	index descriptor	ASCII
		tblspace ID	Hexadecimal
		low rowid	Decimal
		high rowid	Decimal
COARSELOCK	Coarse-grain locking	tblspace ID	Hexadecimal
		old coarse-locking flag value	Decimal
		new coarse-locking flag value	Decimal
CKPOINT	Checkpoint.	max users	Decimal
		number of active transactions	Decimal
CLR	Compensation-log record; created during a rollback.	(None)	(None)
CLUSIDX	Create clustered index.	tblspace ID	Hexadecimal
		key number	Decimal
COLREPAI	Adjust BYTE, TEXT, or VARCHAR column.	tblspace ID	Hexadecimal
		number of columns adjusted	Decimal
COMMIT	Commit work.	date	Decimal
		time	Decimal
COMTAB	Compact slot table on a page.	logical page number	Decimal
		number slots moved	Decimal
		compressed slot pairs	ASCII
COMWORK	End a transaction and commit work.	end transaction time	Decimal
		begin transaction time	Decimal

Table 5-3. Logical-Log Record Types (continued)

Record Type	Action	Additional Columns	Format
DELETE	Delete before-image.	tblspace ID	Hexadecimal
		rowid	Hexadecimal
DELITEM	Delete item from index.	tblspace ID	Hexadecimal
		rowid	Hexadecimal
		logical page	Decimal
		key number	Decimal
		key length	Decimal
DERASE	Drop tblspace in down dbspace.	tblspace number	Hexadecimal
		table lock number	Decimal
DFADDEXT	New extent is added.	partnum	Hexadecimal
		offset of extent entry in list	Hexadecimal
		extent size in pages	Decimal
		physical address of extent	Offset and chunk no-hex
DFDRPEXT	Drop the original extent.	partnum	Hexadecimal
		offset of extent entry in list	Hexadecimal
		original size of this extent	Decimal
		physical address	offset and chunk no-hex
DFEND	End of defragment operation.	partnum	Hexadecimal
DFMVPK	Move page from old extent to new extent.	partnum	Hexadecimal
		offset of new extent	Hexadecimal
		logical page number of source	Hexadecimal
		physical address of destination	Offset and chunk no-hex
		physical address of source	Offset and chunk no-hex
DFREMDUM	Remove the dummy entries.	partnum	Hexadecimal
DFSTART	Start of defragment operation.	partnum	Hexadecimal
DINDEX	Drop index.	tblspace ID	Hexadecimal
		key number	Decimal
DRPBSP	Drop blob space.	blob space name	ASCII
DRPCHK	Drop chunk.	chunk number	Decimal
		chunk name	ASCII
DRPDBS	Drop database.	database name	ASCII
DRPLOG	Drop log.	log number	Decimal
		log size (pages)	Decimal
		pageno	Hexadecimal

Table 5-3. Logical-Log Record Types (continued)

Record Type	Action	Additional Columns	Format
ENDTRANS	<p>Written by both the coordinator and participant database servers to record the end of the transaction. ENDTRANS instructs the database server to remove the transaction entry from its shared-memory transaction table and close the transaction.</p> <p>In the coordinator logical log, each BEGPREP that results in a committed transaction is paired with an ENDTRANS record. If the final decision of the coordinator is to roll back the transaction, no ENDTRANS record is written.</p> <p>In the participant logical log, each ENDTRANS record is paired with a corresponding HEURTX record.</p>	(None)	(None)
ERASE	Drop tblspace.	tblspace ID	Hexadecimal
FREE_RE	Allocate extent from reserve extent to metadata or user-data area of an sbspace chunk.	chunk number	Integer
		page number	Integer
		length	Integer
		flag	Hexadecimal
HDELETE	Delete home row.	tblspace ID	Hexadecimal
		rowid	Hexadecimal
		slotlen	Decimal
HEURTX	Written by a participant database server to record a heuristic decision to roll back the transaction. It should be associated with a standard ROLLBACK record indicating that the transaction was rolled back.	flag	Hexadecimal (Value is always 1.)
HINSERT	Home row insert.	tblspace ID	Hexadecimal
		rowid	Hexadecimal
		slotlen	Decimal
HUPAFT	Home row update, after-image.	tblspace ID	Hexadecimal
		rowid	Hexadecimal
		slotlen	Decimal
HUPBEF	<p>Home row update, before-image.</p> <p>In addition, the flag field of the HUPBEF header may include the following values:</p> <p>LM_PREVLSN Confirms that an LSN exists.</p> <p>LM_FIRSTUPD Confirms that this is the first update for this rowID by this transaction.</p>	tblspace ID	Hexadecimal
		rowid	Hexadecimal
		slotlen	Decimal
		LSN (optional)	Decimal

Table 5-3. Logical-Log Record Types (continued)

Record Type	Action	Additional Columns	Format
HUPDATE	<p>If the home row update before-images and after-images can both fit into a single page, the database server writes a single HUPDATE record.</p> <p>In addition, the flag field of the HUPDATE log may include the following values:</p> <p>LM_PREVLSN Confirms that an LSN exists.</p> <p>LM_FIRSTUPD Confirms that this is the first update for this rowID by this transaction.</p>	tblspace ID	Hexadecimal
		rowid	Hexadecimal
		forward ptr rowid	Hexadecimal
		old slotlen	Decimal
		new slotlen	Decimal
		number of pieces	Decimal
		LSN (optional)	Decimal
IDXFLAGS	Index flags.	tblspace ID	Hexadecimal
		key number	Hexadecimal
INSERT	Insert after-image.	tblspace ID	Hexadecimal
		rowid	Hexadecimal
ISOSPCOMMIT	Log an isolated save-point commit.	end transaction time	Decimal
		begin transaction time	Decimal
LCKLVL	Locking mode (page or row).	tblspace ID	Hexadecimal
		old lockmode	Hexadecimal
		new lockmode	Hexadecimal
LG_ADDBPOOL	Add a buffer pool online.	page size in bytes	Decimal
		number of buffers in the pool	Decimal
		number of lru queues	Decimal
		percent of lru_max_dirty	Decimal
		percent of lru_min_dirty	Decimal
PTRUNCATE	Identifies an intention to truncate a table. The partitions are marked to be dropped or reused, according to the specified command option.	tblspace ID	Hexadecimal
TRUNCATE	TRUNCATE has freed the extents and the transaction will be committed.	tblspace ID	Hexadecimal
MVIDXND	Index node moved to allow for 2-bit to 4-bit bitmap conversion.	tblspace ID	Hexadecimal
		old page number	Decimal
		new page number	Decimal
		parent page number	Decimal
		parent slot number	Decimal
		parent slot offset	Decimal
		key number	Decimal
PBDELETE	Delete tblspace blobpage.	bpageno	Hexadecimal
		status	USED/FREE
		unique ID	Decimal

Table 5-3. Logical-Log Record Types (continued)

Record Type	Action	Additional Columns	Format
PBINSERT	Insert tblspace blobpage.	bpageno	Hexadecimal
		tblspace ID	Hexadecimal
		rowid	Hexadecimal
		slotlen	Decimal
		pbrowid	Hexadecimal
PDINDEX	Predrop index.	tblspace ID	Hexadecimal
PGALTER	Page altered in place.	tblspace ID	Hexadecimal
		physical page number	Hexadecimal
PGMODE	Page mode modified in bitmap.	tblspace ID	Hexadecimal
		logical page number	Decimal
		old mode	Hexadecimal
		new mode	Hexadecimal
PERASE	Preerase old file. Mark a table that is to be dropped. The database server frees the space on the commit.	tblspace ID	Hexadecimal
PNGPALIGN8	Use the pages in this tblspace as generic pages.	None	
PNLOCKID	Change tblspaces lockid.	tblspace ID	Hexadecimal
		old lock ID	Hexadecimal
		new lock ID	Hexadecimal
PNSIZES	Set tblspace extent sizes.	tblspace ID	Hexadecimal
		fextsize	Decimal
		nextsize	Decimal
PREPARE	Written by a participant database server to record the ability of the participant to commit the transaction, if so instructed.	DBSERVERNAME of coordinator	ASCII
PTADESC	Add alter description information.	tblspace ID	Hexadecimal
		physical page number of previous page	Hexadecimal
		logical page number	Decimal
		number of columns added	Decimal
PTALTER	Alter of fragment begun.	tblspace ID	Hexadecimal
		physical page number previous page	Hexadecimal
		logical page number	Decimal
		alter desc page number	Decimal
		num columns added	Decimal
		version of alter	Decimal
		added rowsize	Decimal
PTALTNEWKEYD	Update key descriptors in a tblspace header after an alter table command.	bytes in key descriptor	Decimal
		data in key descriptor	ASCII

Table 5-3. Logical-Log Record Types (continued)

Record Type	Action	Additional Columns	Format
PTALTOLDKEYD	Update key descriptors after an alter table command.	bytes in key descriptor	Decimal
		data in key descriptor	ASCII
PTCOLUMN	Add special columns to fragment.	tblspace ID	Hexadecimal
		number of columns	Decimal
PTEXTEND	Tblspace extend.	tblspace ID	Hexadecimal
		last logical page	Decimal
		first physical page	Hexadecimal
PTRENAME	Rename table.	tblspace ID	Hexadecimal
		old table name	ASCII
		new table name	ASCII
RDELETE	Remainder page delete.	tblspace ID	Hexadecimal
		rowid	Hexadecimal
		slotlen	Decimal
		hrowid (optional)	Decimal
		poffset (optional)	Decimal
RENDBS	Rename dbspace.	new dbspace name	ASCII
REVERT	Logs the reversion of a database space to a database space of an earlier version.	type of reversion event	Decimal
		arg1	Decimal
		arg2	Decimal
		arg3	Decimal
RINSERT	Remainder page insert.	tblspace ID	Hexadecimal
		rowid	Hexadecimal
		slotlen	Decimal
		hrowid (optional)	Decimal
		poffset (optional)	Decimal
ROLLBACK	Rollback work.	date	Decimal
		time	Decimal
ROLWORK	End a transaction and roll back work.	end transaction time	Decimal
		begin transaction time	Decimal
RSVEXTEND	Logs the extension to the reserved pages.	number of pages	Decimal
		physical page number of extent	Hexadecimal
RTREE	Logs inserts and deletions for R-tree index pages. (Other operations on R-tree indexes are physically logged.) The record subtypes are: <ul style="list-style-type: none"> • LEAFINS - insert item in a leaf page • LEAFDEL - delete item from leaf page 	record subtype	ASCII
		[index page rowid	Hexadecimal
		tuple length	Decimal
		base table rowid	Decimal
		base table fragid	Decimal
		delete flag]	Decimal

Table 5-3. Logical-Log Record Types (continued)

Record Type	Action	Additional Columns	Format
BRUPAFT	Remainder page update, after-image.	tblspace ID	Hexadecimal
		rowid	Hexadecimal
		slotlen	Decimal
RUPBEF	Remainder page update, before-image.	tblspace ID	Hexadecimal
		rowid	Hexadecimal
		slotlen	Decimal
		hrowid (optional)	Decimal
		poffset (optional)	Decimal
RUPDATE	If the remainder page update before-images and after-images can both fit into a single page, the database server writes a single RUPDATE record.	tblspace ID	Hexadecimal
		rowid	Hexadecimal
		forward ptr rowid	Hexadecimal
		old slotlen	Decimal
		new slotlen	Decimal
		number of pieces	Decimal
		hrowid (optional)	Decimal
poffset (optional)	Decimal		
SBLOB	<p>Indicates a subsystem log record for a smart large object.</p> <p>The various record subtypes are:</p> <ul style="list-style-type: none"> CHALLOC CHCOMBINE CHFREE CHSPLIT CREATE DELETES EXTEND HDRUPD PDELETE PTRUNC REFCOUNT UDINSERT UDINSERT_LT UDUPAFT UDUPAFT_LT UDUPAFT UDUPAFT_LT UDWRITE UDWRITE_LT 	<p>Varies</p> <p>For more information, see “Log Record Types for Smart Large Objects” on page 5-14.</p>	Varies
SYNC	Written to a logical-log file if that log file is empty and administrator instructs the database server to switch to next log file.	(None)	(None)
TABLOCKS	Written by either a coordinator or a participant database server. It is associated with either a BEGPREP or a PREPARE record and contains a list of the locked tblspaces (by tblspace number) held by the transaction. (In a distributed transaction, transactions are shown as the owners of locks.)	number of locks	Decimal
		tblspace number	Hexadecimal

Table 5-3. Logical-Log Record Types (continued)

Record Type	Action	Additional Columns	Format
UDINSERT	Append new user data.	chunk	Decimal
		page within chunk	Hexadecimal
		offset within page	Hexadecimal
		data length	Hexadecimal
UDUPAFT	Update user data after-image if a UDWRITE is too expensive.	chunk	Decimal
		page within chunk	Hexadecimal
		offset within page	Hexadecimal
		data length	Hexadecimal
UDUPBEF	Update user-data before-image if a UDWRITE is too expensive.	chunk	Decimal
		page within chunk	Hexadecimal
		offset within page	Hexadecimal
		data length	Hexadecimal
UDWRITE	Update user data (difference image).	chunk	Decimal
		page within chunk	Hexadecimal
		offset within chunk	Hexadecimal
		length before write	Hexadecimal
		length after write	Hexadecimal
UNDO	Header record to a series of transactions to be rolled back.	count	Decimal
UNDOBLDC	This record is written if a CREATE TABLE statement should be rolled back but cannot be because the relevant chunk is down. When the log file is replayed, the table will be dropped.	tblspace number	Hexadecimal
UNIQID	Logged when a new SERIAL value is assigned to a row.	tblspace ID	Hexadecimal
		unique ID	Decimal
UNIQ8ID	Logged when a new SERIAL8 value is assigned to a row.	tblspace ID	Hexadecimal
		unique ID	Decimal
UPDAFT	Update after-image.	tblspace ID	Hexadecimal
		rowid	Hexadecimal
UPDBEF	Update before-image.	tblspace ID	Hexadecimal
		rowid	Hexadecimal
XAPREPARE	Participant can commit this XA transaction.	(None)	(None)

Log Record Types for Smart Large Objects

All smart-large-object log records are the SBLOB type. Each smart-large-object log record contains six header columns, described in “Logical-Log Record Header” on page 5-2; the record subtype; and additional information. The information that appears varies, depending on record subtype.

Table 5-4 lists all the smart-large-object record types. The **Subtype** column describes the smart-large-object record type. The **Action** column indicates the type of database server action that generated the log entry. The **Additional Columns** and **Format** columns describe what information appears for each record type.

Table 5-4. Record Subtypes for Smart Large Objects

Record Subtype	Action	Additional Columns	Format
CHALLOC	Allocate chunk extent.	extent [chk, page, len]	Decimal
		flags	Hexadecimal
CHCOMBINE	Combine two pages in the user-data extent list.	chunk number	Decimal
		first page	Decimal
		second page	Decimal
CHFREE	Frees chunk extent.	extent [chk, page, len]	Decimal
CHSPLIT	Split a page in the user-data extent list.	chunk number	Decimal
		UDFET page to split	Decimal
CREATE	Create smart large object.	smart-large-object ID [sbs, chk, page, oid]	Decimal
		number of extents in lomaphdr	Decimal
DELETE	Delete a smart large object at commit.	smart-large-object ID [sbs, chk, page, oid]	Decimal
EXTEND	Add extent to an extent list of a smart large object.	smart-large-object ID [sbs, chk, page, oid]	Decimal
		extent [chk, page, len]	Decimal
		lomap overflow page number	Decimal
HDRUPD	Update smart-large-object header page.	smart-large-object ID [sbs, chk, page, oid]	Decimal
		old EOF offset	String
		new EOF offset	String
		old times	Decimal
		new times	Decimal
PDELETE	Queue a smart large object for deletion at commit.	smart-large-object ID [sbs, chk, page, oid]	Decimal
PTRUNC	Queue a smart large object for truncation at commit.	smart-large-object ID [sbs, chk, page, oid]	Decimal
		old offset	String
		new offset	String
REFCOUNT	Increment or decrement the reference count of a smart large object.	smart-large-object ID [sbs, chk, page, oid]	Decimal
		1 if increment; 0 if decrement	Decimal
UDINSERT, UDINSERT_LT	Append new user data.	chunk	Decimal
		page within chunk	Decimal
		offset within page	Decimal
		data length	Decimal

Table 5-4. Record Subtypes for Smart Large Objects (continued)

Record Subtype	Action	Additional Columns	Format
UDUPAFT, UDUPAFT_LT	Update user-data after-image if a UDWRITE is too expensive.	chunk	Decimal
		page within chunk	Decimal
		offset within page	Decimal
		data length	Decimal
UDUPBEF, UDUPBEF_LT	Update user-data beforeimage if a UDWRITE is too expensive.	chunk	Decimal
		page within chunk	Decimal
		offset within page	Decimal
		data length	Decimal
UDWRITE, UDWRITE_LT	Update user data (difference image).	chunk	Decimal
		page within chunk	Decimal
		offset within page	Decimal
		length before write	Decimal
		length after write	Decimal
		number of different image pieces	Decimal

For an example of smart-large-object records in **onlog** output, see smart-large-object log records in the chapter on what is the logical log in the *IBM Informix Administrator's Guide*.

Figure 5-1 shows an example of smart-large-object records in **onlog** output. The first two records show that an extent was freed. The next group of records, flanked by BEGIN and COMMIT, shows the allocation of storage and creation of the smart large objects.

addr	len	type	xid	id	link	subtype	specific-info
4e8428	40	SBLOB	8	0	4e7400	CHFREE	(2,53,421)
4e8450	40	SBLOB	8	0	4e8428	CHFREE	(2,579,421)
c8018	40	BEGIN	8	3	0	07/13/98	10:23:04 34 informix
c8040	264	SBLOB	8	0	c8018	CREATE	[2,2,1,900350517] 10
c8148	44	SBLOB	8	0	c8040	CHALLOC	(2,53,8) 0x1
c8174	68	SBLOB	8	0	c8148	EXTEND	[2,2,1,900350517] (2,53,8) -1
c81b8	264	SBLOB	8	0	c8174	CREATE	[2,2,2,900350518] 10
c82c0	44	SBLOB	8	0	c81b8	CHALLOC	(2,61,1) 0x1
c82ec	68	SBLOB	8	0	c82c0	EXTEND	[2,2,2,900350518] (2,61,1) -1
c8330	56	SBLOB	8	0	c82ec	REFCOUNT	[2,2,1,900350517] 1
c8368	56	SBLOB	8	0	c8330	REFCOUNT	[2,2,2,900350518] 1
c83a0	36	COMMIT	8	0	c8368	07/13/98	10:23:05
c83c4	40	BEGIN	8	3	0	07/13/98	10:23:05 34 informix
c83ec	264	SBLOB	8	0	c83c4	CREATE	[2,2,3,900350519] 10
c84f4	44	SBLOB	8	0	c83ec	CHALLOC	(2,62,1) 0x1
c8520	68	SBLOB	8	0	c84f4	EXTEND	[2,2,3,900350519] (2,62,1) -1
c8564	56	SBLOB	8	0	c8520	REFCOUNT	[2,2,3,900350519] 1
c859c	36	COMMIT	8	0	c8564	07/13/98	10:23:05

Figure 5-1. Smart-Large-Object Records in onlog Output

Part 2. Administrative Utilities

Chapter 6. Overview of Utilities

The Informix database server utilities allow you to perform administrative tasks directly from the command line.

For a complete list of server utilities, see <http://publib.boulder.ibm.com/infocenter/idshelp/v117/topic/com.ibm.sa.doc/utilities.htm>.

The database server utilities support multibyte command-line arguments. For a complete list of the utilities that support multibyte command-line arguments, see the .

The database server must be online before you execute a utility, with the following exceptions:

- **oninit**
- Some **onlog** options
- Some **oncheck** options

Note: When using utilities, do not use the UNIX command CTRL-C to send an interrupt signal to a process because it might produce an error.

Obtaining Utility Version Information

Many Informix command-line utilities allow you to obtain version information using **-V** and **-version** options. You use the **-V** and **-version** options primarily for debugging. When a Technical Support representative asks for the version number, you can use the **-V** and **-version** options to find the information.

The **-V** option displays the software version number and the serial number.

The **-version** option extends the **-V** option to display additional information on the build operation system, build number, and build date.

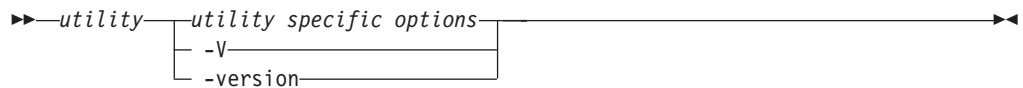

The **-V** and **-version** options cannot be used with any other utility options. For example, the **onstat -version** command might display the following output.

```
onstat -version
```

```
Program:          onstat
Build Version:    11.70.FC1
Build Host:       connla
Build OS:         SunOS 5.6
Build Number:     009
Build Date:       Sat Nov 20 03:38:27 CDT 2010
GLS Version:      glslib-4.50.xc2
```

The **onstat -V** command might display the following information:

```
IBM Informix Version 11.70.FC1  Software Serial Number
RDS#N0000000
```

IBM Informix Server Administrator

IBM Informix Server Administrator (ISA) allows a DBA to manage Informix database servers by executing Informix commands from any web browser. You do not need to be familiar with the syntax and format of database server commands. ISA presents the command output in an easy-to-read format.

ISA is available for download at <http://www.ibm.com/software/data/informix/downloads.html>.

With ISA, you can perform these database server administrative tasks:

- Change configuration parameters temporarily or permanently.
- Use **Server Setup** to configure or reconfigure the database server.
- Change the database server mode.
- Modify connectivity information in the **sqlhosts** file.
- Check dbspaces, blobspaces, and sbspaces.
- Manage logical logs and physical logs.
- Examine and modify memory usage.
- Read the message log.
- Back up and restore dbspaces, blobspaces, and sbspaces.
- Run various **onstat** commands to monitor performance.
- Enter SQL statements and examine database schemas.
- Add and remove chunks, dbspaces, blobspaces, sbspaces.
- Examine and manage user sessions.
- Examine and manage virtual processors (VPs).
- Use the High-Performance Loader (HPL), **dbimport**, and **dbexport**.
- Manage Enterprise Replication.
- Manage an Informix MaxConnect server.
- Set up primary and secondary database servers for High-Availability Data Replication.
- Use the following utilities: **dbaccess**, **dbschema**, **onbar**, **oncheck**, **ondblog**, **oninit**, **onlog**, **onmode**, **onparams**, **onspaces**, **onstat**, **onpladm**.
- Enter any Informix utility, UNIX shell command, or Windows command.

Chapter 7. The finderr utility

Use the **finderr** utility to view additional information on Informix error messages. On UNIX and Linux platforms, the information appears on the command line. On Windows platforms, the information appears in the Error Messages program.

Syntax

► finderr -
+
- error_number ►

Table 7-1. finderr element

Element	Purpose	Key Considerations
<i>error_number</i>	The error message number for which to provide additional information	<p>On UNIX or Linux: If you do not include a minus sign (-) or plus sign (+) and both a positive and a negative version of the error message exists, the negative version of the message is displayed. To display the information about an error message number that is positive, preface the error number with a plus sign.</p> <p>On Windows: If you do not include a minus sign or plus sign and both a positive and a negative version of the error message exists, you must choose which message you want to view in the Error Messages program.</p>

Usage

Error messages that are printed in the message log include a message number and a short message description. Use the message number with the **finderr** command to look up a more detailed description of the cause of the error and possible user actions to correct or prevent the error.

On Windows, you can open the Error Messages program directly by choosing **Error Messages** from the database server program group.

Examples

The following command on a UNIX or Linux platform displays information about the error message -201:

```
finderr 201
```

```
-201 A syntax error has occurred.
```

This general error message indicates mistakes in the form of an SQL statement. Look for missing or extra punctuation (such as missing or extra commas, omission of parentheses around a subquery, and so on), keywords misspelled (such as VALEUS for VALUES), keywords misused (such as SET in an INSERT statement or INTO in a subquery), keywords out of sequence (such as a condition of "value IS NOT" instead of "NOT value IS"), or a reserved word used as an identifier.

Database servers that provide full NIST compliance do not reserve any words; queries that work with these database servers might fail and return error -201 when they are used with earlier versions of IBM Informix database servers.

The cause of this error might be an attempt to use round-robin syntax with CREATE INDEX or ALTER FRAGMENT INIT on an index. You cannot use round-robin indexes.

The error may also occur if an SQL statement uses double quotation marks around input strings and the environment variable DELIMIDENT is set. If DELIMIDENT is set, strings that are surrounded by double quotation marks are regarded as SQL identifiers rather than string literals. For more information on the usage of DELIMIDENT, see the IBM Informix Guide to SQL: Reference.

The following command displays information about the error message 100, which corresponds to the SQLCODE value of 100:

```
finderr +100
```

```
100 No matching records found.
```

The database server did not find any more data. This message is an ANSI-standard SQLCODE value. If you attempted to select or fetch data, you encountered the end of the data, or no data matched the criteria in the WHERE clause. Check for an empty table. Use this SQLCODE value to determine when a statement reaches the end of the data. For more information, see the discussion of SQLCODE in the IBM Informix ESQL/C Programmer's Manual. The database server can return this SQLCODE value to a running program.

For the High-Performance Loader (HPL), this message can indicate that the map might be from a project other than the default project. Use the -p option in the onpload command line to provide a project name for mappings.

Chapter 8. The genoncfg Utility

Use the **genoncfg** utility to expedite the process of customizing the default Informix configuration file (**onconfig.std**) to the host environment and your planned usage of a database server instance.

Syntax

```

genoncfg input_file [informixdir]
        -h
        -V
        -version
  
```

Element	Purpose	Key Considerations
<i>input_file</i>	Name of the input file containing your parameter settings.	
<i>informixdir</i>	Path to the Informix installation that you want to configure.	You can omit the installation path if the INFORMIXDIR environment variable is set. If the INFORMIXDIR variable is already set and you enter an installation path on the command line, the utility runs with the command-line path.
-h	Help information about the genoncfg utility.	
-V	Displays short version information and exits the command-line utility.	
-version	Displays extended version information and exits the command-line utility.	

Usage

Log in to the host computer as root or user **informix** before you run this utility.

You must set parameters that are valid for your host environment in an input file before you can successfully run the **genoncfg** utility. For all environments, the parameter **disk** is required in the input file. You can also enter directives in the input file. The directives are not required to run the utility, but they can be helpful in some circumstances.

The utility does not read or modify any existing configuration file. If you have a pre-existing ONCONFIG file in the host environment, none of its parameter values are changed when you run the utility. Therefore, you can review the recommended configuration settings before you put them in effect on a database server instance.

To use the genoncfg utility:

1. Create the input file containing your values for the parameters that the **genoncfg** utility processes with a text editor.
2. Run the utility with your input file. The configuration file (named **onconfig**) is generated and saved in the working directory.
3. *Optional:* Rename the generated configuration file.

4. If you want to run a database server instance with the generated configuration file, copy the file to \$INFORMIXDIR/etc and update the **ONCONFIG** environment variable accordingly.

Input File for the **genoncfg** Utility

Use the input file to specify the following information about the database server instance:

- number of anticipated online transaction processing (OLTP) connections
- number of anticipated decision-support systems (DSS) connections
- disk space
- CPU utilization
- network connection settings
- recovery time

The input file is an ASCII text file. There is no required order for the parameters. The following is an example of an input file:

```
cpus 1
memory 1024 m
connection name demo_on onsoctcp 9088
servernum 1
oltp_connections 10
dss_connections 2
disk /opt/IBM/informix/demo/server/online_root 0 k 300 m
directive one_crit
directive debug
```

*Table 8-1. Parameters of the Input File for the **genoncfg** Utility*

Parameter	Description
connection	<p>Server connection parameters:</p> <ul style="list-style-type: none"> • name or alias, depending on whether the connection functions with a specific server name (the DBSERVERNAME parameter of the configuration file) or with an alternative server name (using the DBSERVERALIASES parameter of the configuration file) • name for the connection • type of server connection (equivalent to NETTYPE in the configuration file) • port number for the service <p>Example: connection name demo_on onsoctcp 9088</p>
cpus	<p>Number of central processing units (CPUs) to allocate the instance. Example: cpus 1</p>

Table 8-1. Parameters of the Input File for the **genoncfg** Utility (continued)

Parameter	Description
directive	<p>Directives that can be used with the genoncfg utility.</p> <ul style="list-style-type: none"> • one_crit: Configures the database server to store physical logs, logical logs, and data in the root dbspace only. • debug: Displays information in real time about the host environment and actions done on the configuration file. <p>Example: <code>directive one_crit</code></p> <p>This information can be helpful in troubleshooting problems with database server configuration. One scenario is that the <code>debug</code> directive can result in saving time. In this scenario, you read the displayed information and notice that the utility is creating an <code>onconfig</code> file that you do not want or that will not function. You stop the utility while it is still running, adjust the input file settings, and then rerun the utility with the modified input file.</p>
disk	<p>Disk storage space settings for the instance:</p> <ul style="list-style-type: none"> • location of the root dbspace • size of offset, in megabytes (m) or kilobytes (k) • size of root dbspace, in megabytes (m) or kilobytes (k) <p>Example:</p> <p>UNIX: <code>/opt/IBM/dspace/rootdbs</code></p> <p>Windows: <code>d:\INFXDATA\rootdbs</code></p> <p>Important: If you enter a path location that is the root dbspace of a working instance, the instance is overwritten and made unusable.</p>
dss_connections	<p>Estimated number of decision-support systems (DSS) connections to the instance. For example, a query client or other application that obtains result sets for business intelligence can be a DSS connection. Example: <code>dss_connections 2</code></p>
memory	<p>Amount of memory, in megabytes (m), for the instance. Example: <code>memory 1024 m</code></p>
oltp_connections	<p>Estimated number of online transaction processing (OLTP) connections to the instance. Typically, an application that modifies the state of databases in the instance is an OLTP connection. Example: <code>oltp_connections 10</code></p>

Table 8-1. Parameters of the Input File for the **genoncfg** Utility (continued)

Parameter	Description
rto_server_restart	Specifies the amount of time, in seconds, that the database server has to recover from a problem after you restart Informix and bring it into online or quiescent mode. The value can be set either to 0 to disable the configuration parameter or to a value between 60 and 1800 to enable the parameter and indicate the number of seconds. Example: rto_server_restart 100 specifies the recovery time objective as 100 seconds.
servernum	Unique ID of the database server instance. Example: servernum 1

Chapter 9. The oncheck Utility

Use the **oncheck** utility to check specified disk structures for inconsistencies, repair inconsistent index structures, and display information about disk structures.

The **oncheck** utility requires sort space when examining an index. The amount of sort space required is the same as that needed to build the index. For information about calculating the amount of temporary space needed, see Estimating temporary space for index builds (Performance Guide). If you receive the error "no free disk space for sort," you must estimate the amount of temporary space needed and make that space available.

You can use SQL administration API commands that are equivalent to some **oncheck** commands.

oncheck Check-and-Repair

The **oncheck** utility can repair the following types of disk structures:

- Partition page statistics
- Bitmap pages
- Partition blobpages
- Blobospace blobpages
- Indexes
- Sbspace pages
- Metadata partitions for sbspaces

If **oncheck** detects inconsistencies in other structures, messages alert you to these inconsistencies, but **oncheck** cannot resolve the problem. For more information, see the chapter on consistency checking in the *IBM Informix Administrator's Guide* and Chapter 4, "Disk Structures and Storage," on page 4-1.

What Does Each Option Do?

As Table 9-1 on page 9-2 shows, the **oncheck** options fall into three categories: check, repair, and display. The display or print options (those prefixed with the letter **p**) are identical in function to the **-c** options, except that the **-p** options display additional information about the data that is being checked as the **oncheck** utility executes. You cannot combine **oncheck** option flags except as the following paragraphs describe.

In general, the **-c** options check for consistency and display a message on the screen only if they find an error or inconsistency.

Any user can execute the check options. On UNIX platforms, you must be user **informix** or **root** to display database data or initiate repair options. On Windows, you must be a member of the **Informix-Admin** group to display database data or initiate repair options.

Table 9-1 associates **oncheck** options with their function. It also shows the SQL administration API *command* strings that are equivalent to the **oncheck -c** options.

Table 9-1. *oncheck* Options and Their Function

Object	Check	SQL administration API <i>command</i> string	Repair	Display
Blobspace simple large objects				-pB
System catalog tables	-cc			-pc
Data rows, no simple large objects or smart large objects	-cd			-pd
Data rows, simple large objects but no smart large objects	-cD			-pD
Table with a user-defined access method	-cd, -cD	CHECK DATA		
Chunks and extents	-ce	CHECK EXTENTS		-pe
Index (key values)	-ci, -cix		-ci -y -pk -y, -pkx -y	-pk
Index (keys plus rowids)	-cI, -cIx		-cI -y -pK -y, -pKx -y	-pK
Index with a user-defined access method	-ci, -cI			
Index (leaf key values)			-pl -y, -plx -y	-pl
Index (leaf keys plus rowids)			-pL -y, -pLx -y	-pL
Pages (by table or fragment)				-pp
Pages (by chunk)				-pP
Root reserved pages	-cr, -cR			-pr, -pR
Metadata for smart large objects	-cs, -cS			-ps, -pS
Space usage (by table or fragment)		CHECK PARTITION PRINT PARTITION		-pt
Space usage (by table, with indexes)				-pT

Using the -y Option to Perform Repairs

Use the **-y** option to instruct **oncheck** to perform repairs automatically, as the following examples show:

```
oncheck -cd -y
oncheck -cD -y
oncheck -ci -y
oncheck -cI -y
```

If you do not use the **-y** option, **oncheck** prompts you when it encounters an inconsistency and allows you to request a repair. If you specify option **-n**, **oncheck** does not prompt you because this option instructs **oncheck** to not perform repairs.

Repairing Indexes in Sbspaces and External Spaces

The **oncheck** utility can repair an index in an sbspace or external space if the index is created using an access method that supports the **oncheck -y** option. Although the **oncheck** utility does not repair fragmented indexes, user-defined access methods can repair them. For more information about the **oncheck** options that access methods support, see the *IBM Informix DataBlade API Programmer's Guide* or the *IBM Informix Virtual-Index Interface Programmer's Guide*.

Locking and oncheck

The **oncheck** utility places a shared lock on a table during the following operations, so no other users can perform updates, inserts, or deletes until the check has completed:

- When it checks data
- When it checks indexes (with **-ci**, **-cI**, **-pk**, **-pK**, **-pl**, or **-pL**) and the table uses page locking
- When you specify the **-x** option with **-ci**, **-cI**, **-pk**, **-pK**, **-pl**, or **-pL** and the table uses row locking

If the table does not use page locking, the database server does not place a shared lock on the table when you check an index with the **oncheck -ci**, **-cI**, **-pk**, **-pK**, **-pl**, or **-pL** options. When no shared lock is on the table during an index check, other users can update rows during the check.

By not placing a shared lock on tables using row locks during index checks, the **oncheck** utility cannot be as accurate in the index check. For absolute assurance of a complete index check, you can execute **oncheck** with the **-x** option. With the **-x** option, **oncheck** places a shared lock on the table, and no other users can perform updates, inserts, or deletes until the check has completed.

The **oncheck** utility returns unreliable results when run on secondary servers in a high-availability cluster.

For more information about the **-x** option, refer to “Turn On Locking with -x” on page 9-21. For information on shared locks and intent shared locks, see the *IBM Informix Performance Guide*.

The **oncheck** utility places a shared lock on system catalog tables when they are checked. It places an exclusive lock on a table when it executes repair options.

oncheck syntax

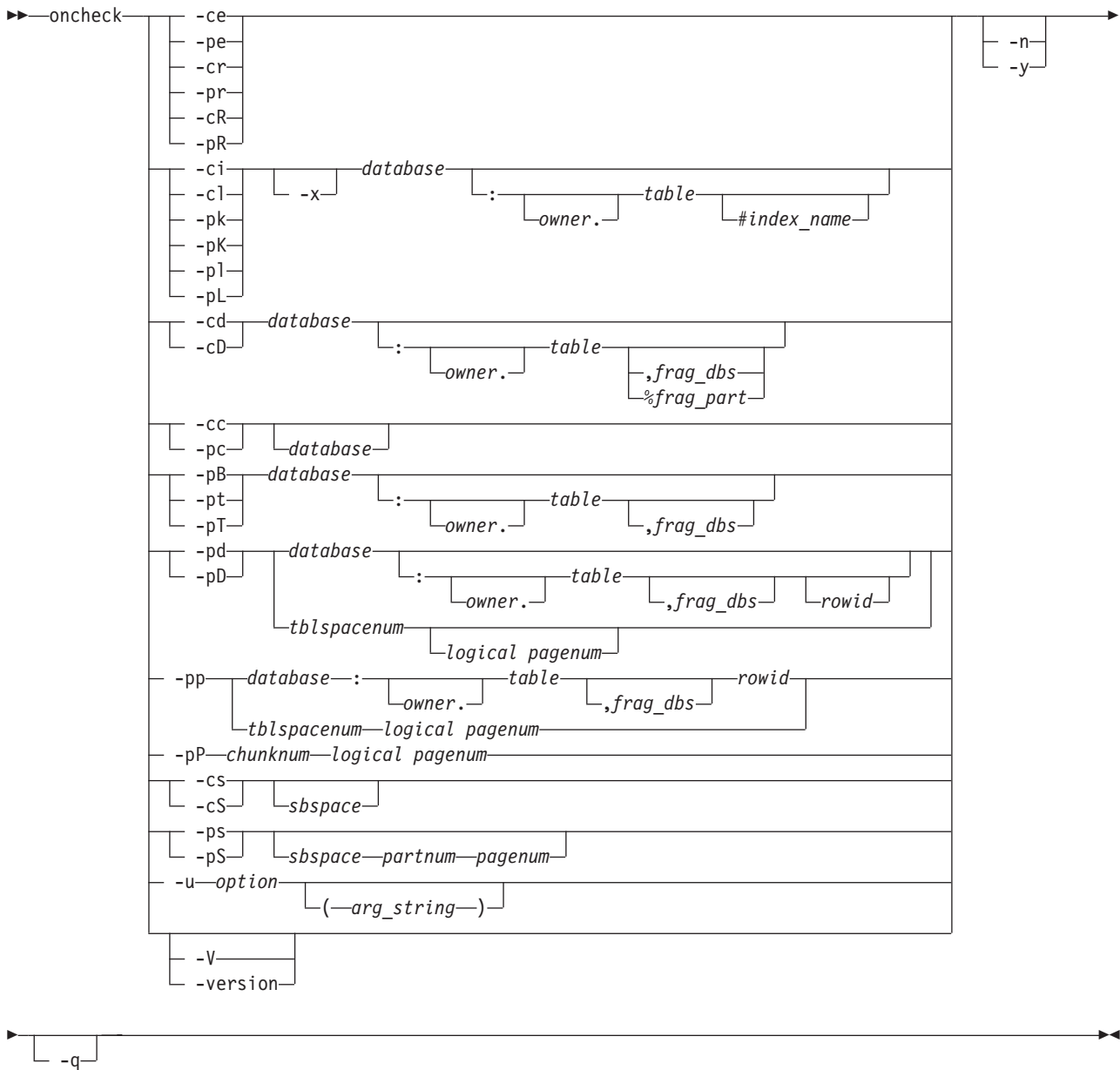

Element	Purpose	Key Considerations
-cc	Checks system catalog tables for the specified database	See "oncheck -cc and -pc: Check system catalog tables" on page 9-8.
-cd	Reads all pages except simple large objects from the tblspace for the specified database, table, or fragment and checks each page for consistency Also checks tables that use a user-defined access method	Does not check simple or smart large objects. See "oncheck -cd and oncheck -cD commands: Check pages" on page 9-8.
-cD	Same as -cd but also reads the header of each blobpage and checks it for consistency	Checks simple large objects but not smart large objects. See "oncheck -cd and oncheck -cD commands: Check pages" on page 9-8.

Element	Purpose	Key Considerations
-ce	Checks each chunk-free list and corresponding free space and each tblspace extent. Also checks smart-large-object extents and sbspace metadata	The oncheck process verifies that the extents on disk correspond to the current control information that describes them. See “oncheck -ce, -pe: Check the chunk-free list” on page 9-10. For background information, see “Next-Extent Allocation” on page 4-10.
-ci	Checks the ordering of key values and the consistency of horizontal and vertical node links for all indexes associated with the specified table Also checks indexes that use a user-defined access method	See “ oncheck -ci and -cI : Check index node links” on page 9-10.
-cI	Same as -ci but also checks that the key value tied to a rowid in an index is the same as the key value in the row	See “ oncheck -ci and -cI : Check index node links” on page 9-10.
-cr	Checks each of the root dbspace reserved pages for several conditions	See “oncheck -cr and -cR: Check reserved pages” on page 9-12.
-cR	Checks the root dbspace reserved pages, physical-log pages, and logical-log pages	See “oncheck -cr and -cR: Check reserved pages” on page 9-12
-cs	Checks smart large object and sbspace metadata for an sbspace	See “oncheck -cs, -cS, -ps, -pS: Check and display sbspaces” on page 9-13.
-cS	Checks smart large object and sbspace metadata for an sbspace as well as extents	See “oncheck -cs, -cS, -ps, -pS: Check and display sbspaces” on page 9-13.
sbspace	Indicates optional sbspace name If not supplied, all sbspaces are checked.	None.
-n	Indicates that no index repair should be performed, even if errors are detected	Use with the index repair options (-ci , -cI , -pk , -pK , -pl , and -pL).
-pB	Displays statistics that describe the average fullness of blobpage blobpages in a specified table	These statistics provide a measure of storage efficiency for individual simple large objects in a database or table. If a table or fragment is not specified, statistics are displayed for the entire database. See “oncheck -pB: Display blobpage statistics” on page 9-13. For information about optimizing blobpage size, see the chapter on managing disk space in the <i>IBM Informix Administrator's Guide</i> .
-pc	Same as -cc but also displays the system catalog information as it checks the system catalog tables, including extent use for each table	None.
-pd	Displays rows in hexadecimal format	See “oncheck -pd and pD: Display rows in hexadecimal format” on page 9-13.

Element	Purpose	Key Considerations
-pD	Displays rows in hexadecimal format and simple-large-object values stored in the tblspace or header information for smart large objects stored in an sbspace sbpage and simple large objects stored in a blobospace blobpage	See “oncheck -pd and pD: Display rows in hexadecimal format” on page 9-13.
-pe	Same as -ce but also displays the chunk and tblspace extent information as it checks the chunk free list, the corresponding free space, and each tblspace extent	See “oncheck -ce, -pe: Check the chunk-free list” on page 9-10.
-pk	Same as -ci but also displays the key values for all indexes on the specified table as it checks them	See “oncheck -pk, -pK, -pl, -pL: Display index information” on page 9-15.
-pK	Same as -ci but also displays the key values and rowids as it checks them	See “oncheck -pk, -pK, -pl, -pL: Display index information” on page 9-15.
-pl	Same as -ci but also displays the key values. Only leaf-node index pages are checked	See “oncheck -pk, -pK, -pl, -pL: Display index information” on page 9-15.
-pL	Same as -ci but also displays the key values and rowids for leaf-node index pages only	See “oncheck -pk, -pK, -pl, -pL: Display index information” on page 9-15.
-pp	Displays contents of a logical page	See “oncheck -pp and -pP: Display the contents of a logical page” on page 9-16.
-pP	Same as -pp but requires a chunk number and logical page number or internal rowid as input	See “oncheck -pp and -pP: Display the contents of a logical page” on page 9-16.
-pr	Same as -cr but also displays the reserved-page information as it checks the reserved pages	See “oncheck -pr and pR: Display reserved-page information” on page 9-18.
-pR	Same as -cr but also displays the information for the reserved pages, physical-log pages, and logical-log pages	See “oncheck -pr and pR: Display reserved-page information” on page 9-18.
-ps	Checks and displays smart-large-object and sbspace metadata for an sbspace	See “oncheck -cs, -cS, -ps, -pS: Check and display sbspaces” on page 9-13.
-pS	Checks and displays smart-large-object and sbspace metadata. Lists extents and header information for individual smart large objects	See “oncheck -cs, -cS, -ps, -pS: Check and display sbspaces” on page 9-13.
-pt	Displays tblspace information for a table or fragment	See “oncheck -pt and -pT: Display tblspaces for a Table or Fragment” on page 9-19.
-pT	Same as -pt but also displays index-specific information and page-allocation information by page type (for dbspaces)	See “oncheck -pt and -pT: Display tblspaces for a Table or Fragment” on page 9-19.
-q	Suppresses all checking and validation message	None.
-x	Places a shared lock on the table when you check and print an index	Use with the -ci , -ci , -pk , -pK , -pl , or -pL options. For complete information, see “Turn On Locking with -x” on page 9-21.

Element	Purpose	Key Considerations
-y	Repairs indexes when errors are detected	None.
-V	Displays the software version number and the serial number	See "Obtaining Utility Version Information" on page 6-1.
-version	Displays the build version, host, OS, number and date, as well as the GLS version	See "Obtaining Utility Version Information" on page 6-1.
<i>chunknum</i>	Specifies a decimal value that you use to indicate a particular chunk	Value must be an unsigned integer greater than 0. Chunk must exist. Execute the -pe option to learn which chunk numbers are associated with specific dbspaces, blobspaces or sbspaces.
<i>database</i>	Specifies the name of a database that you want to check for consistency	Syntax must conform to the Identifier segment; see <i>IBM Informix Guide to SQL: Syntax</i> .
db1	Specifies the local database that contains a data type that you want to check	Optionally specify the local database server name using the format db1@server1 .
db2	Specifies the remote database that contains a data type that you want to check	Optionally specify the remote database server name using the format db2@server2 .
<i>frag_dbs</i>	Specifies the name of a dbspace that contains a fragment you want to check for consistency	Dbspace must exist and contain the fragment that you want to check for consistency. Syntax must conform to the Identifier segment; see <i>IBM Informix Guide to SQL: Syntax</i> .
<i>index_name</i>	Specifies the name of the index that you want to check for consistency	Index must exist on table and in database specified. Syntax must conform to the Identifier segment; see <i>IBM Informix Guide to SQL: Syntax</i> .
<i>logical pagenum</i>	Specifies an integer value that you use to indicate a particular page in a tblspace	Value must be an unsigned integer between 0 and 16,777,215, inclusive. Value can be expressed as an unsigned integer or hexadecimal that begins with 0x identifier.
<i>object</i>	Specifies the name of the DataBlade, cast, operator, user-defined data type, or UDR that you want to check	If you do not specify an object name, the database server compares all objects of the same type with the same name and owner.
<i>owner</i>	Specifies the owner of a table	You must specify the current owner of the table. Syntax must conform to the Owner Name segment; for more information, see <i>IBM Informix Guide to SQL: Syntax</i> .
<i>pagenum</i>	Indicates the page number of the sbspace metadata portion to check and display	None.
<i>partnum</i>	Identifies the sbspace metadata partition to check and display	None.
<i>rowid</i>	Identifies the rowid of the row whose contents you want to display. The rowid is displayed as part of oncheck -pD output	Value must be an unsigned integer between 0 and 4,277,659,295, inclusive. Value can be expressed as an unsigned integer or hexadecimal that begins with 0x identifier.
<i>sbspace</i>	Specifies the name of the sbspace that you want to check for consistency	None.

Element	Purpose	Key Considerations
<i>server</i>	Specifies the database server name	If you omit the database server name, oncheck uses the name that INFORMIXSERVER specifies.
<i>table</i>	Specifies the name of the table that you want to check for consistency	Table exists when you execute the utility. Syntax must conform to the Table Name segment; for more information, see <i>IBM Informix Guide to SQL: Syntax</i> .
<i>tblspacenum</i>	Identifies the tblspace whose contents you want to display	Value must be an unsigned integer between 0 and 208,666,624, inclusive. Value can be expressed as an unsigned integer or hexadecimal that begins with 0x identifier.

oncheck -cc and -pc: Check system catalog tables

Syntax:

```

▶▶ oncheck [-cc] [-pc] database

```

The **-cc** option checks all system catalog tables for the specified database. If you do not specify a database, it checks all system catalog tables for all databases.

The **-pc** option performs the same checks on system catalog tables and also displays the system catalog information, including the physical address, type of locking used, row size, number of keys, extent use, the number of pages allocated and used, tblspace partnum, and index use for each table.

Before you execute **oncheck -cc** or **oncheck -pc**, execute the SQL statement UPDATE STATISTICS to ensure that an accurate check occurs. To check a table, **oncheck** compares each system catalog table to its corresponding entry in the tblspace. For more information about the tblspace, see "Structure of the Tblspace Tblspace" on page 4-4.)

oncheck -cd and oncheck -cD commands: Check pages

Use the **oncheck -cd** and **oncheck -cD** commands to check each page for consistency.

Syntax:

```

▶▶ oncheck [-cd] [-cD] database [table] [owner.] [frag_dbs] [%frag_part]

```

The **oncheck -cd** command reads all pages, except for blobpages and sbpages, from the tblspace for the specified database, table, fragment, or multiple fragments (fragparts), and checks each page for consistency. This command compares entries in the bitmap page to the pages to verify mapping.

The **oncheck -cD** command performs the same checks as the **oncheck -cd** command, and also checks the header of each blobpage for consistency. The **oncheck -cD** command does not compare the beginning time stamps stored in the

header with the ending time stamps stored at the end of a blobpage. Use the **oncheck -cD -y** command to clean up orphaned simple large objects in blobspaces, which may occur after a rollback across several log files.

If the database contains fragmented tables, but no fragment is specified, the **oncheck -cd** command checks all fragments in the table. If you do not specify a table, the command checks all of the tables in the database. By comparison, the **oncheck -pd** command displays a hexadecimal dump of specified pages but does not check for consistency.

For both the **oncheck -cd** and **oncheck -cD** commands, the **oncheck** utility locks each table as it checks the indexes for the table. To repair the pages, use **oncheck -cd -y** or **oncheck -cD -y**.

If tables are fragmented on multiple partitions in the same dbspace, the **oncheck -cd** and **oncheck -cD** commands show the partition names. The following example shows typical output for a table that has fragments in multiple partitions in the same dbspace:

```
TBLspace data check for multipart:informix.t1
      Table fragment partition part_1 in DBspace dbs1
      Table fragment partition part_2 in DBspace dbs1
      Table fragment partition part_3 in DBspace dbs1
      Table fragment partition part_4 in DBspace dbs1
      Table fragment partition part_5 in DBspace dbs1
```

When you use the **oncheck -cd** or **oncheck -cD** command, you can specify either the *frag_dbs* or the *%frag_dbs* option but not both:

- When you use the *frag_dbs* option, the utility checks all fragments in the dbspace *frag_dbs*.
- When you use the *%frag_dbs* option, the utility checks only the fragment named *frag_part*, if the PARTITION syntax was used when the fragment or table was created.

While it is possible to fragment an index with the PARTITION syntax, it is not possible to limit an index check to just one fragment or partition. For example, you can specify **oncheck -cDI my_db:my_tab,data_dbs1** or **oncheck -cDI my_db:my_tab%part1**. The "D" (data) portion of the check is limited according to the specification, however the "I" (index) check is not limited.

Examples

The following example checks the data rows, including simple large objects and smart large objects, in the **catalog** table:

```
oncheck -cD superstores_demo:catalog
```

If you specify a single fragment, the **oncheck** utility displays a single header for that fragment. For fragmented tables, one header is displayed for each fragment:

```
TBLspace data check for stores_demo:informix.tab1
      Table fragment in DBspace db1
```

Messages

If the **oncheck** utility finds no inconsistencies, a header displays for each table that the utility. For example:

```
TBLSPACE data check for stores_demo:informix.customer
```

If the **oncheck** utility finds an inconsistency a message displays. For example:
BAD PAGE 2:28: pg_addr 2:28 != bp-> bf_pagenum 2:69

The physical address 2:28 represents page 28 of chunk number 2.

If an index that uses an access method provided by a DataBlade module cannot find the access method, you receive the following message:

-9845 Access method *access_method_name* does not exist in database.
Ensure that the DataBlade installation was successful.

Reference

To monitor blobspace blobpages, refer to the **oncheck -pB** command for information at “oncheck -pB: Display blobpage statistics” on page 9-13).

Use CHECK DATA as the SQL administration API *command* string for the **oncheck -cd** command.

Related reference:

“check data argument: Check data consistency (SQL administration API)” on page 22-23

oncheck -ce, -pe: Check the chunk-free list

Syntax:

▶▶ oncheck [-ce] [-pe] ▶▶

The **-ce** option checks each chunk-free list and corresponding free space and each tblspace extent. For more information, refer to “Next-Extent Allocation” on page 4-10 and “Structure of the Chunk Free-List Page” on page 4-4, respectively. The **oncheck** process verifies that the extents on disk correspond to the current control information that describes them.

The **-pe** option performs the same checks and also displays the chunk and tblspace extent information during the check. The **-ce** and **-pe** options also check blobspaces, smart-large-object extents, and user-data and metadata information in sbspace chunks.

For information about using **oncheck -ce** and **-pe**, see managing disk space in the *IBM Informix Administrator's Guide*.

Use CHECK EXTENTS as the SQL administration API *command* string for **oncheck -ce**.

Related reference:

“check extents argument: Check extent consistency (SQL administration API)” on page 22-24

oncheck -ci and -cl: Check index node links

Use the **oncheck -ci** and **oncheck -cl** commands to check the ordering of key values and the consistency of horizontal and vertical node links for all indexes associated with the specified table.

The **oncheck -cI** command also checks that the key value tied to a rowid in an index is the same as the key value in the row. The **-cI** option does not cross-check data on a functional index.

Syntax:

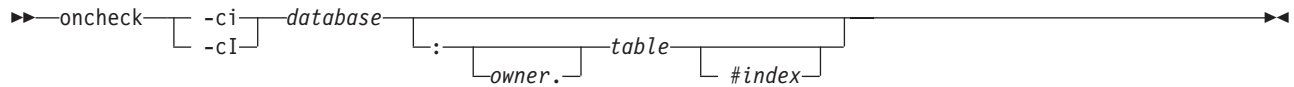

If you do not specify an index, the option checks all indexes. If you do not specify a table, the option checks all tables in the database.

The same **-ci** repair options are available with **-cI**. If **oncheck -ci** or **oncheck -cI** detects inconsistencies, it prompts you for confirmation to repair the problem index. If you specify the **-y** (yes) option, indexes are automatically repaired. If you specify the **-n** (no) option, the problem is reported but not repaired; no prompting occurs.

If **oncheck** does not find inconsistencies, the following message appears:
 validating indexes.....

The message displays the names of the indexes that **oncheck** is checking.

Note: Using **oncheck** to rebuild indexes can be time consuming. Processing is usually faster if you use the SQL statements DROP INDEX and CREATE INDEX to drop and re-create the index.

The following example checks all indexes on the **customer** table:
 oncheck -cI -n stores_demo:customer

The following example checks the index **zip_ix** on the **customer** table:
 oncheck -cI -n stores_demo:customer#zip_ix

If indexes are fragmented on multiple partitions in the same dbspace, the **oncheck -ci** and **oncheck -cI** commands show the partition names. The following example show typical output for an index that has fragments in multiple partitions in the same dbspace:

```

Validating indexes for multipart:informix.t1...
Index idx_t1
Index fragment partition part_1 in DBspace dbs1
Index fragment partition part_2 in DBspace dbs1
Index fragment partition part_3 in DBspace dbs1
Index fragment partition part_4 in DBspace dbs1
Index fragment partition part_5 in DBspace dbs1
  
```

By default, the database server does not place a shared lock on the table when you check an index with the **oncheck -ci** or **oncheck -cI** commands unless the table uses page locking. For absolute assurance of a complete index check, you can execute **oncheck -cior oncheck -cI** with the **-x** option. With the **-x** option, **oncheck** places a shared lock on the table, and no other users can perform updates, inserts, or deletes until the check has completed. For more information about using **oncheck -ci** and **oncheck -cI** with the **-x** option, "Turn On Locking with -x" on page 9-21.

When you execute **oncheck** on an external index, the user-defined access method is responsible for checking and repairing an index. If an index that employs a user-defined access method cannot find the access method, the database server reports an error. The **oncheck** utility does not repair inconsistencies in external indexes. You should not use **oncheck -cI** on a table that contains more than one type of index.

The **oncheck** utility requires sort space when examining an index. The amount of sort space required is the same as that needed to build the index. For information about calculating the amount of temporary space needed, see Estimating temporary space for index builds (Performance Guide). If you receive the error "no free disk space for sort," you must estimate the amount of temporary space needed and make that space available.

Important: If you are using the Verity Text Search DataBlade Module, the **-cI** option performs an index merge instead of the usual operations.

For more information about indexes, see "Structure of B-Tree Index Pages" on page 4-16.

oncheck -cr and -cR: Check reserved pages

Syntax:

```
▶▶ oncheck [ -cr ] [ -cR ] ▶▶
```

The **-cr** option checks each of the root dbspace reserved pages as follows:

- It validates the contents of the ONCONFIG file with the PAGE_CONFIG reserved page.
- It ensures that all chunks can be opened, that chunks do not overlap, and that chunk sizes are correct.

The **-cR** option performs the same checking and validation, and also checks all logical-log and physical-log pages for consistency. The **-cr** option is considerably faster because it does not check the log-file pages.

If you have changed the value of a configuration parameter (either through ISA, **onparams**, **onmonitor**, **onspaces**, or by editing the configuration file), but you have not yet reinitialized shared memory, **oncheck -cr** and **oncheck -cR** detect the inconsistency and return an error message.

If **oncheck -cr** does not display any error messages after you execute it, you can assume that all three items in the preceding list were checked successfully.

For more information on reserved pages, see "Reserved Pages" on page 4-2.

oncheck -cs, -cS, -ps, -pS: Check and display sbspaces

Syntax:

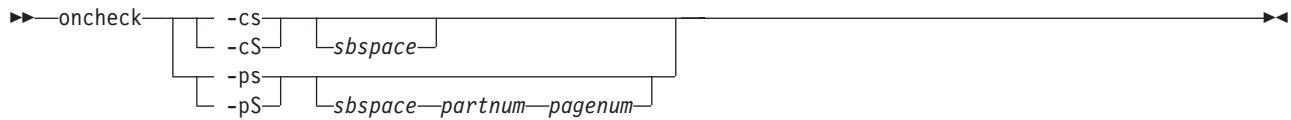

The **-cs** option checks sbspaces. The **-ps** option checks sbspaces and extents.

The **-cS** option validates and displays metadata for an sbspace.

The **-ps** option checks sbspaces and extents. If you do not specify the sbspace name, these options check all sbspaces.

The **-pS** option validates and displays metadata for an sbspace and also lists extents and header information for smart large objects.

If you do not specify the sbspace name, all sbspaces will be checked. The following example checks and displays metadata for **test_sbspace**:

```
oncheck -ps test_sbspace
```

If you specify **rootdbs** as the sbspace name with the **-cs** or **-ps** options, **oncheck** checks the root dbspace.

For more information about using the **-cs**, **-cS**, **-ps**, and **-pS** options, see the *IBM Informix Administrator's Guide*.

oncheck -pB: Display blobspace statistics

Syntax:

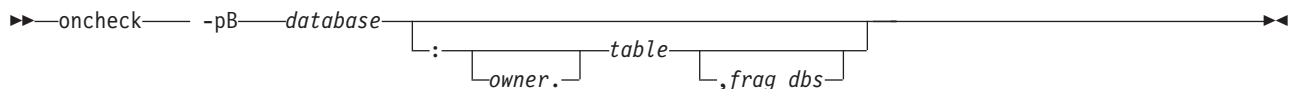

The **-pB** option displays statistics that describe the average fullness of blobpage blobpages in a specified table. These statistics provide a measure of storage efficiency for individual simple large objects in a database or table. If you do not specify a table or fragment, the option displays statistics for the entire database. For more information, see optimizing blobpage blobpage size in the chapter on managing disk space in the *IBM Informix Administrator's Guide*.

oncheck -pd and pD: Display rows in hexadecimal format

Syntax:



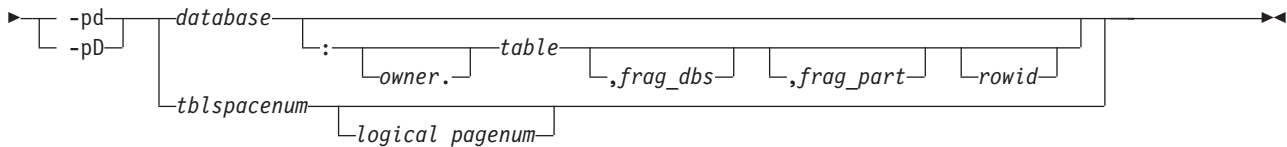

The **-pd** option takes a database, a table, a fragment, a fragment partition (fragpart), and a specific rowid or tblspace number and logical page number as input. In every case, **-pd** prints page-header information and displays the specified rows for the database object (database, table, fragment, internal rowid, or page number) that you specify in hexadecimal and ASCII format. No checks for consistency are performed.

Element	Purpose	Key Considerations
<i>database</i>	Specifies the name of a database that you want to check for consistency	Syntax must conform to the Identifier segment; see <i>IBM Informix Guide to SQL: Syntax</i> .
<i>frag_dbs</i>	Specifies the name of a dbspace that contains a fragment you want to check for consistency	Dbspace must exist and contain the fragment that you want to check for consistency. Syntax must conform to the Identifier segment; see <i>IBM Informix Guide to SQL: Syntax</i> .
<i>frag_part</i>	Specifies the fragment partition	For fragmented tables or an index that use expression-based or round-robin distribution schemes, you can create multiple partitions, which are collections of pages for a table or index, within a single dbspace. This partition is referred to as a <i>fragment partition</i> or <i>fragpart</i> .
<i>logical pagenum</i>	Specifies an integer value that you use to indicate a particular page in a tblspace	Value can be expressed as an unsigned integer or hexadecimal that begins with 0x identifier. Value must be an unsigned integer between 0 and 16,777,215, inclusive.
<i>owner</i>	Specifies the owner of a table	You must specify the current owner of the table. Syntax must conform to the Owner Name segment; see <i>IBM Informix Guide to SQL: Syntax</i> .
<i>rowid</i>	Identifies the rowid of the row whose contents you want to display. The rowid is displayed as part of oncheck -pD output	Value must be an unsigned integer between 0 and 4,277,659,295, inclusive. Value can be expressed as an unsigned integer or hexadecimal that begins with 0x identifier.
<i>table</i>	Specifies the name of the table that you want to check for consistency	Table exists when you execute the utility. Syntax must conform to the Table Name segment; see <i>IBM Informix Guide to SQL: Syntax</i> .
<i>tblspacenum</i>	Identifies the tblspace whose contents you want to display	Value must be an unsigned integer between 0 and 208,666,624, inclusive. Value can be expressed as an unsigned integer or hexadecimal that begins with 0x identifier.

If you specify an internal rowid (expressed as a hexadecimal value), the rowid maps to a particular page, and all rows from that page are printed.

If you specify a logical page number (expressed as a decimal), all the rows of the tblspace number with the logical page number are printed.

Element	Purpose	Key Considerations
<i>database</i>	Specifies the name of a database that you want to check for consistency	Syntax must conform to the Identifier segment; see <i>IBM Informix Guide to SQL: Syntax</i> .
<i>chunknum</i>	Specifies a decimal value that you use to indicate a particular chunk	Value must be an unsigned integer greater than 0. Chunk must exist.
<i>frag_dbs</i>	Specifies the name of a dbspace that contains a fragment you want to check for consistency	Dbspace must exist and contain the fragment that you want to check for consistency. Syntax must conform to the Identifier segment; see <i>IBM Informix Guide to SQL: Syntax</i> .
<i>frag_part</i>	Specifies the partition name of the fragment to be checked. This is useful in cases where more than one fragment of a table was created in the same dbspace.	For fragmented tables or an index that use expression-based or round-robin distribution schemes, you can create multiple partitions, which are collections of pages for a table or index, within a single dbspace. This partition is referred to as a <i>fragment partition</i> or <i>fragpart</i> .
<i>logical pagenum</i>	Specifies an integer value that you use to indicate a particular page in a tblspace	Value can be expressed as an unsigned integer or hexadecimal that begins with 0x identifier. Value must be an unsigned integer between 0 and 16,777,215, inclusive.
<i>owner</i>	Specifies the owner of a table	You must specify the current owner of the table. Syntax must conform to the Owner Name segment; see <i>IBM Informix Guide to SQL: Syntax</i> .
<i>rowid</i>	Identifies the rowid of the row whose contents you want to display. The rowid is displayed as part of oncheck -pD output	Value must be an unsigned integer between 0 and 4,277,659,295, inclusive. Value can be expressed as an unsigned integer or hexadecimal that begins with 0x identifier.
<i>table</i>	Specifies the name of the table that you want to check for consistency	Table exists when you execute the utility. Syntax must conform to the Table Name segment; see <i>IBM Informix Guide to SQL: Syntax</i> .
<i>tblspacenum</i>	Identifies the tblspace whose contents you want to display	Value must be an unsigned integer between 0 and 208,666,624, inclusive. Value can be expressed as an unsigned integer or hexadecimal that begins with 0x identifier.

The **-pp** option has the following syntax variations:

Invocation	Explanation
oncheck -pp tblspc lpn <pages>	Displays the contents of a logical page using a tblspace number and logical page number. You can also specify an optional parameter specifying the number of pages to be printed.
oncheck -pp tblspc lpn -h	Displays only the header of a logical page using a tblspace number and logical page number.
oncheck -pp database:table rowid	Displays the contents of a logical page using a database name, table name, and an Informix internal rowid. You can obtain this internal rowid with the oncheck -pD command. This internal rowid is not the serial rowid that is assigned in tables created with the CREATE TABLE tablename WITH ROWIDS statement. For more information, see "Definition of Rowid" on page 4-13

The page contents appear in ASCII format. The display also includes the number of slot-table entries on the page. The following example shows different invocations of the **oncheck -pp** command:

```
oncheck -pp stores_demo:orders 0x211 # database:owner.table, # fragment rowid
oncheck -pp stores_demo:informix.customer,frag_dbspcel 0x211
oncheck -pp 0x100000a 25 # specify the tblspace number and # logical page number
```

The **-pP** option provides the following syntax variations:

Invocation	Explanation
oncheck -pP chunk# offset pages	Displays the contents of a logical page using a chunk number and an offset. You can also specify an optional parameter specifying the number of pages to be printed.
oncheck -pP chunk# offset -h	Displays only the header of a logical page using a chunk number and an offset.

Note: The output for chunk page displays both the start and the length fields in decimal format.

The following example shows typical output using the **onstat -pP** command:

```
oncheck -pP 1 5 2
addr      stamp      nslots      flag      type      frptr      frcnt      next      prev
stamp     100005      250181      2         1000      ROOTRSV    320        1716     0
0         250181      slot        ptr        len        flg
...
addr      stamp      nslots      flag      type      frptr      frcnt      next      prev
stamp     100005      6          250182    2         1000      ROOTRSV    128      1908     0
250182    slot        ptr        len        flg        1         24         56        0
2         80         48         0
```

oncheck -pr and pR: Display reserved-page information

Syntax:

```
▶▶ oncheck [ -pr ] [ -pR ] ▶▶
```

The **-pr** option performs the same checks as **oncheck -cr** and displays the reserved-page information.

The **-pR** option performs the same checks as **oncheck -cR**, displays the reserved-page information, and displays detailed information about logical-log and physical-log pages, marking the start and end of the active physical-log pages.

If you have changed the value of a configuration parameter (either through ISA or by editing the configuration file), but you have not yet reinitialized shared memory, **oncheck -pr** and **oncheck -pR** detect the inconsistency and return an error message.

For a listing and explanation of **oncheck -pr** output, see “Reserved Pages” on page 4-2. For a description of the **-cr** option, see “oncheck -cr and -cR: Check reserved pages” on page 9-12.

oncheck -pt and -pT: Display tablespaces for a Table or Fragment

The **oncheck -pt** and **oncheck -pT** options print a tablespace report for a specific table or fragment. The only difference between these options is that **oncheck -pT** prints more information, including some index-specific information.

Syntax:

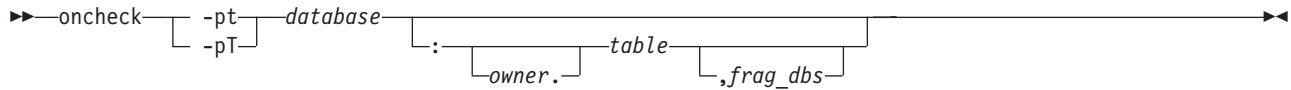

Element	Purpose	Key Considerations
<i>database</i>	Specifies the name of a database that you want to check for consistency	Syntax must conform to the Identifier segment; see <i>IBM Informix Guide to SQL: Syntax</i> .
<i>frag_dbs</i>	Specifies the name of a dbspace that contains a fragment you want to check for consistency	Dbspace must exist and contain the fragment that you want to check for consistency. Syntax must conform to the Identifier segment; see <i>IBM Informix Guide to SQL: Syntax</i> .
<i>owner</i>	Specifies the owner of a table	You must specify the current owner of the table. Syntax must conform to the Owner Name segment; see <i>IBM Informix Guide to SQL: Syntax</i> .
<i>table</i>	Specifies the name of the table that you want to check for consistency	Table exists when you execute the utility. Syntax must conform to the Table Name segment; see <i>IBM Informix Guide to SQL: Syntax</i> .

The **-pt** option prints a tablespace report for the table or fragment with the name and database that you specify when you execute **oncheck** at the command line. The report contains general allocation information including the maximum row size, the number of keys, the number of extents, their sizes, the pages allocated and used per extent, the current serial value, and the date that the table was created. The **-pt** output prints the pagesize of the tablespace, the number of pages (allocated, used and data) in terms of logical pages. The **Extents** fields list the physical address for the tablespace **tablespace** entry for the table and the address of the first page of the first extent. The extent list shows the number of logical as well as physical pages in every extent. If you do not specify a table, the option displays this information for all tables in the database.

The **-pT** option prints the same information as the **-pt** option. In addition, the **-pT** option displays:

- Index-specific information
- Page-allocation information by page type (for dbspaces)
- The number of any compressed rows in a table or table fragment and the percentage of table or table-fragment rows that are compressed
If table or fragment rows are not compressed, the "Compressed Data Summary" section does not appear in the output.

Plan when you want to run the **-pT** option, because it forces a complete scan of partitions.

Output for both **-pt** and **-pT** contains listings for **Number of pages used**. The value shown in the output for this field is never decremented because the disk space allocated to a tblspace as part of an extent remains dedicated to that extent even after you free space by deleting rows. For an accurate count of the number of pages currently used, refer to the detailed information on tblspace use (organized by page type) that the **-pT** option provides.

Example of oncheck -pt Output

The following example shows output of the **oncheck -pt** command:

TBLspace Report for testdb:tbl

```
Physical Address      2:10
Creation date        10/07/2004 17:01:16
TBLspace Flags      801          Page Locking
                                TBLspace use 4 bit bit-maps

Maximum row size    14
Number of special columns  0
Number of keys      0
Number of extents   1
Current serial value 1
Pagesize (k)        4
First extent size   4
Next extent size    4
Number of pages allocated 340
Number of pages used 337
Number of data pages 336
Number of rows      75806
Partition partnum   2097154
Partition lockid    2097154
```

```
Extents
      Logical Page   Physical Page   Size Physical Pages
              0             2:106         340           680
```

Example of oncheck -pT Output

The following example shows output of the **oncheck -pT** command:

TBLspace Report for database_a:nilesh.table_1a

Table fragment partition dbspace1 in DBspace dbspace1

```
Physical Address      3:5
Creation date        03/21/2009 15:35:47
TBLspace Flags      8000901    Page Locking
                                TBLspace contains VARCHARS
                                TBLspace use 4 bit bit-maps
                                TBLspace is compressed

Maximum row size    80
Number of special columns  1
Number of keys      0
Number of extents   1
Current serial value 100001
Current SERIAL8 value 1
Current BIGSERIAL value 1
Current REFID value  1
Pagesize (k)        2
First extent size   8
Next extent size    8
Number of pages allocated 24
Number of pages used 22
Number of data pages 14
Number of rows      500
Partition partnum   3145730
```

```

Partition lockid          3145730

Extents
  Logical Page      Physical Page      Size Physical Pages
           0              3:16053          24          24

Type                Pages      Empty Semi-Full      Full Very-Full
-----
Free                9
Bit-Map             1
Index               0
Data (Home)        14
Data (Remainder)   0          0          0          0          0
-----
Total Pages        24

Unused Space Summary

  Unused data bytes in Home pages      1177
  Unused data bytes in Remainder pages    0

Home Data Page Version Summary

  Version                                Count
  0 (current)                            14

Compressed Data Summary

  Number of compressed rows and percentage of compressed rows  500 100.00

```

For more examples of using **oncheck -pt** and **-pT**, see managing disk space in the *IBM Informix Administrator's Guide* and the *IBM Informix Performance Guide*.

Related reference:

“check partition argument: Check partition consistency (SQL administration API)” on page 22-24

“print partition argument: Print partition information (SQL administration API)” on page 22-99

Turn On Locking with -x

The **-x** option can be appended to the **-ci**, **-cl**, **-pk**, **-pK**, **-pl**, and **-pL** options to place a shared lock on affected tables. While the table is locked, no other users can perform inserts, updates, and deletions while **oncheck** checks or prints the index. Without the **-x** option for tables with row locking, **oncheck** only places an IS (intent shared) lock on the table, which prevents actions such as dropping the table or the indexes during the check.

For example, the following sample command instructs **oncheck** to lock indexes for the **customer** table while it validates the order of key values, validates horizontal links, and ensures that no node appears twice in the index:

```
oncheck -cix stores_demo:customer
```

When you specify option **-x**, **oncheck** locks indexes for tables that use row locking. If **oncheck** detects page-lock mode, it displays a warning message and places a shared lock on the table regardless.

Send Special Arguments to the Access Method with -u

You can use the **-u** option to send special arguments to the access method. The possible arguments depend on the access method. For example, the R-tree access method supports the **display** option, as the following example shows:

```
oncheck -p1 -u "display"
```

Use commas to separate multiple arguments in the argument string.

For information on valid arguments for your access method, refer to the user manual for your access method.

Return Codes on Exit

The **oncheck** utility returns the following codes on exit.

```
GLS failures:-1  
Invalid serial/key:2  
Onconfig access error:2  
Invalid onconfig settings:2  
Invalid arguments to oncheck:2  
Error connecting database server:1  
error detected by oncheck:2  
no errors detected by oncheck:0
```

Windows only:

```
Not properly installed:1  
Authentication error:2
```

Chapter 10. The onclean Utility

Use the **onclean** utility to force a shut down of the database server when normal shut down with the **onmode** utility fails or when you cannot restart the server. The **onclean** utility attempts to clean up shared memory, semaphores, and stops database server virtual processes.

Syntax

On UNIX and Linux, you must be user **root** or **informix** to run the **onclean** command. On Windows, you must be in the **Informix-Admin** group to run the command.



Table 10-1. Syntax Elements of the **onclean** Command

Element	Purpose
-k	Shuts down a server that is online by stopping database server virtual processes and attempting to clean up the remaining semaphores and shared-memory segments, even if they are still running.
-V	Displays short version information.
-version	Displays full version information.
-y	Does not prompt for confirmation.

Usage

Use the **onclean** utility to stop the database server only if the **onmode** utility is unable to shut it down or you cannot restart the server. Perhaps the database server shut down in an uncontrolled way and cannot recover, or it is hung. If the database server fails to restart, the previous instance of the database server is still attached to the shared-memory segments. Check the message log to see if the database server shut down abnormally. The **onclean** utility stops all **oninit** processes and attempts to remove all shared-memory segments and semaphores that are recorded in the **\$INFORMIXDIR/etc/.conf.\$INFORMIXSERVER** file.

Attention: Use the **onclean** utility with caution. When you run **onclean**, any pending transactions and processes fail to complete, and user sessions are disconnected abruptly. However, the database server rolls back transactions when it restarts.

The **INFORMIXDIR**, **INFORMIXSERVER**, **INFORMIXSQLHOSTS**, and **ONCONFIG** environment variables must be set with valid values to run this utility.

The **onclean** command you should use depends on the situation:

- If you are not sure whether the database server is offline, use the **onclean** command without options. If the database server is still online, a message appears directing you to run the **onclean -k** command.
- If the database server is offline, use the **onclean** command.
- If the database server is online and you are sure that you want to force it to shut down, use the **onclean -k** command.

You can only use the **onclean** utility to shut down the local database server; you cannot use it to shut down a remote database server. The **onclean** utility should not be used to shut down an entire high-availability cluster or a remote database server.

The **onclean** utility might not be able to clean up shared memory segments that were in use by the database server in every situation. The **onclean** utility attempts to terminate only **oninit** processes. The **onclean** utility does not succeed in the following situations:

- If a non-database server process is attached to the shared memory segment prior to running the **onclean** command, the **onclean** utility does not stop this process to remove the shared memory segment.
- The **onclean** might not be able to guarantee a clean server startup is when an application or database server utility is connected to a network port. If the user tries to initialize a database server instance on the same network port, then the database server cannot start the listener thread and fails to start. The **onclean** utility does not stop the application to free the network port.

You can automate shutting down the database server with the **onshutdown** script, which calls the **onclean -ky** command if necessary.

Return Codes

- | | |
|---|--|
| 0 | Successful |
| 1 | Failure because of one of the following problems: <ul style="list-style-type: none"> • Incorrect environment variable settings • Incorrect privileges to run the onclean command • Incorrect command syntax • Corrupted information • Running the onclean command without the -k option on a server that is still online |
| 2 | Failure because one or more OS system calls used by onclean returned an error. |

Related reference:

“Taking the Database Server to Offline Mode with the **-k** Option” on page 15-17

The onshutdown script

Use the **onshutdown** script to automate shutting down the database server. The script attempts to shut down the server normally. If the server has not shut down after a specified time, the script forces the server to shut down.

Syntax

The **onshutdown** script first runs the **onmode -ky** command. After a specified wait time, the script runs the **onclean -ky** command.

On UNIX and Linux, you must be user **root** or **informix** to run the **onshutdown** script. On Windows, you must be in the **Informix-Admin** group to run the **onshutdown** script.

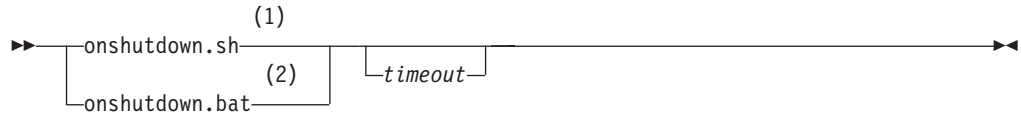

Notes:

- 1 UNIX
- 2 Windows

Table 10-2. Syntax Elements of the onshutdown Script

Element	Purpose
<i>timeout</i>	The number of seconds after the onmode -ky command has been run before running the onclean -ky command. Must be a positive integer from 10 to 60. The default value is 30 seconds.

Usage

Use the **onshutdown** script only when forcing the database server to shut down would be appropriate.

Attention: Use the **onshutdown** script with caution. If the script needs to run the **onclean -ky** command, any pending transactions and processes fail to complete, and user sessions are disconnected abruptly. However, the database server rolls back transactions when it restarts.

The **INFORMIXDIR**, **INFORMIXSERVER**, **INFORMIXSQLHOSTS**, and **ONCONFIG** environment variables must be set with valid values to run this utility.

You can only use the **onshutdown** script to shut down the local database server; you cannot use it to shut down a remote database server. The **onshutdown** script should not be used to shut down an entire high-availability cluster or a remote database server instance.

The **onshutdown** script has a 10 second time period during which it can be aborted.

Related reference:

“Taking the Database Server to Offline Mode with the -k Option” on page 15-17

Chapter 11. The oncmsm utility

Use the **oncmsm** utility to start the Connection Manager. You configure the Connection Manager by using a configuration file.

Syntax

UNIX syntax diagram:

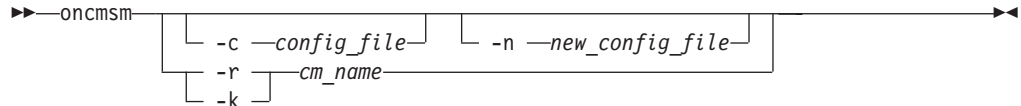

Windows syntax diagram:

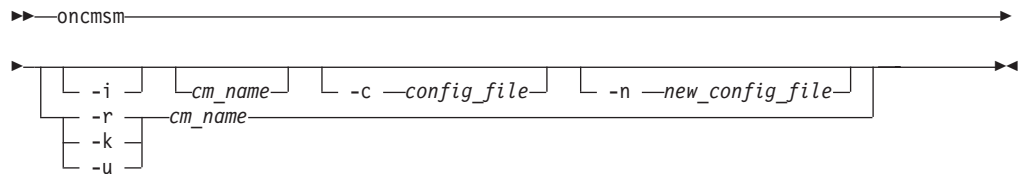

Element	Purpose	Key considerations
-c <i>config_file</i>	Identifies the path and file name of a configuration file that contains service level agreements and failover options.	If the configuration file name is omitted, the Connection Manager attempts to load the file from the following path and file name: \$INFORMIXDIR/etc/cmsm.cfg
<i>cm_name</i>	Specifies the name of the Connection Manager instance.	
-i	Installs the Connection Manager as a Windows service.	This option is valid for Windows platforms only.
-k <i>cm_name</i>	Shuts down a specific instance of the Connection Manager.	Use <i>cm_name</i> to specify the name of the Connection Manager instance.
-n <i>new_config_file</i>	Specifies the path and file name of a configuration file that will contain a converted version of an old Connection Manager configuration file.	Use this option to convert configuration files to the latest Connection Manager format.
-r <i>cm_name</i>	Reloads the Connection Manager settings.	Use the -r option to reload Connection Manager settings without stopping and restarting the Connection Manager.
-u	Uninstall the Connection Manager Windows service.	This option is valid for Windows platforms only.

Usage

Run the **oncmsm** utility from the command line to initialize the Connection Manager. For more information and examples of using the **oncmsm** utility, refer to the *IBM Informix Administrator's Guide*.

You can add, change, or delete Service Level Agreements (SLAs) while the Connection Manager is running by modifying the Connection Manager configuration file and reload it by using the `-r` option. You can reuse an SLA name after it has been deleted.

UNIX Only: Only user **informix** can run the **oncmsm** command. If user **root** or a member of the DBSA group is granted privileges to connect to the sysadmin database, then user **root** or that member of the DBSA group can also run **oncmsm**.

Windows Only:

- You must be a member of the **Informix-Admin** group to run the **oncmsm** utility. If user **administrator** or a member of the DBSA group is granted privileges to connect to the sysadmin database, then user **administrator** or that member of the DBSA group can also run **oncmsm**.
- You must first install **oncmsm** as a service. Two additional options can be passed on the **oncmsm** command line. Use the `-i` option to install **oncmsm** as a Windows service, and `-u` to uninstall the service. After **oncmsm** is installed as a Windows service, it can be started from either a command line by running **oncmsm** or it can be started from the **Services** program (click **Start**, click **Control Panel**, double-click **Administrative Tools**, and then double-click **Services**).

For increased readability of the configuration file, you can break long lines into smaller ones by using a backslash (`\`) as a line continuation character. The following example shows a macro definition separated into four lines:

```
MACRO  srv1list=node1,node2,node3,node4, \
        node6,node7,node8,           \
        node100,node101,              \
        node500,node501
```

Connection Manager configuration file

Most of the Connection Manager options are specified in a configuration file. The configuration file consists of two main parts: the heading and the body. The heading contains Connection Manager configuration options that specify the instance name and other optional parameters. The body consists of one or more connection unit sections that define the type and name of the connection unit, service level agreements, failover configuration and so on. The general format of the configuration file is as follows:

```
# *** HEADING ***
NAME          cm_name

# Optional configuration file parameters
MACRO         macro_name=(macro_list)
LOG           log_errors
LOGFILE       log_file_path_and_file_name
DEBUG         debug_value
EVENT_TIMEOUT timeout_value

# *** BODY ***
# Connection Unit 1
Group_type    connection_unit_name
{
  INFORMIXSERVER server_list
  SLA          SLA_name SLA_attribute=SLA_value
  FOC          ORDER=server_list | DISABLED | NOTIFY
              TIMEOUT=FOC_timeout
              RETRY=FOC_retry
  CMALARMPROGRAM event_alarm_program
```

```

}
# Connection Unit 2
Group_type      connection_unit_name
{
  INFORMIXSERVER server_list
  SLA             SLA_name SLA_attribute=SLA_value
  FOC            ORDER=server_list | DISABLED | NOTIFY
                TIMEOUT=FOC_timeout
                RETRY=FOC_retry
  CMALARMPROGRAM event_alarm_program
}
.
.
.
# Connection Unit n
Group_type      connection_unit_name
{
  INFORMIXSERVER server_list
  SLA             SLA_name SLA_attribute=SLA_value
  FOC            ORDER=server_list | DISABLED | NOTIFY
                TIMEOUT=FOC_timeout
                RETRY=FOC_retry
  CMALARMPROGRAM event_alarm_program
}

```

Connection manager configuration file parameters

The following table lists the parameters that you can use in different sections of the Connection Manager configuration file. For more information about each parameter, follow the link to it from the table. The parameters are described in alphabetical order after the table.

Table 11-1. Mandatory and optional parameters for different parts of the Connection Manager configuration file

Part of the configuration file	Mandatory parameters	Optional parameters
Heading configuration file parameters	NAME	LOGFILE DEBUG LOG MACRO TYPE CM_TIMEOUT SQLHOSTS SLA_WORKERS EVENT_TIMEOUT SECONDARY_EVENT_TIMEOUT CMALARMPROGRAM
Section for a high-availability cluster	SLA FOC INFORMIXSERVER	EVENT_TIMEOUT CMALARMPROGRAM SLA_WORKERS
Section for a grid, replicate set, or server set	SLA INFORMIXSERVER	EVENT_TIMEOUT CMALARMPROGRAM SLA_WORKERS

CMALARMPROGRAM=*event_alarm_program*

Specifies the path and file name of a program or script to run if failover processing encounters an error. If failover processing fails, then the Connection Manager calls the program specified by CMALARMPROGRAM.

CM_TIMEOUT=*value*

Specifies the amount of time, in seconds, for the database server to wait for

events from the Connection Manager. If the server does not receive any events from the Connection Manager within the specified period of time, the server assumes that the Connection Manager is inoperative. If the inoperative Connection Manager is the failover arbitrator, then the next available Connection Manager becomes the failover arbitrator. If `CM_TIMEOUT` is not specified, the default timeout value is 60 seconds.

DEBUG *value*

Specifies whether to enable or disable debug mode. Set the **DEBUG** parameter to 1 to log SQL and ESQL/C error messages. Set the **DEBUG** parameter to 0 or remove the **DEBUG** parameter from the configuration file to disable debug mode. You cannot enable debug mode from the command line.

EVENT_TIMEOUT=*timeout_value*

Specifies the amount of time, in seconds, for the Connection Manager to wait for events from the primary server before beginning failover processing. An *event* in this context is an indication from the primary server that the server is still functioning, such as a performance statistics message, a node change message, or an administration message. If the Connection Manager does not receive any events from the primary server within the specified period of time, the Connection Manager assumes that the primary server is inoperative and failover processing starts. If the **EVENT_TIMEOUT** parameter is not specified, the Connection Manager waits 60 seconds before beginning failover processing. If the **EVENT_TIMEOUT** parameter is set to -1, the Connection Manager waits indefinitely for events from the primary server, or until it receives notification from one of the secondary servers that the primary server is off line. The minimum value for the **EVENT_TIMEOUT** parameter is 30 seconds. The Connection Manager sets the **EVENT_TIMEOUT** parameter to 30 seconds if a value less than 30 is specified.

FOC ORDER=*server_list* | **DISABLED** | **NOTIFY**

TIMEOUT=*FOC_timeout*

RETRY=*FOC_retry*

Specifies the failover configuration (FOC) that the Connection Manager uses to determine which server should take over in case the primary server fails.

Important: If the FOC parameter is enabled and failover processing occurs, you must not restart the failed primary server manually until failover processing completes.

When configuring multiple Connection Manager instances to manage a high-availability cluster, each Connection Manager instance for a given cluster must be configured with identical FOC settings. If your Connection Manager instance manages more than one high-availability cluster, each cluster can have a different failover configuration, as long as the failover configuration for a given cluster is identical within each Connection Manager instance.

The FOC parameter must be set to **DISABLED** if the connection unit type is **REPLSET**.

If the FOC parameter is not specified, the following default value is used:

`FOC ORDER=SDS,HDR,RSS TIMEOUT=0 RETRY=1`

Table 11-2. FOC parameters

Parameter	Description
ORDER=	<p>SDS Specifies an SD (Shared Disk) secondary server</p> <p>HDR HDR (High-Availability Data Replication) secondary server</p> <p>RSS RS (Remote Standalone) secondary server</p> <p>DISABLED Specifies that failover processing by the Connection Manager is disabled. If failover is disabled, the Connection Manager ignores failover requests.</p> <p>NOTIFY Specifies the Connection Manager to send alarm messages to the parameter specified by the CMCALARMPROGRAM parameter.</p> <p>The ORDER parameter specifies the order in which secondary servers take over the role of the primary server in case the primary server fails. The ORDER parameter is specified using a comma-separated list of servers or server alias names, a server type, or a previously defined macro.</p> <p>For example, the following failover configuration indicates that the HDR server should take over if the primary server fails, followed by the first available shared disk secondary server (SDS), followed by the list of servers defined by the CA macro, followed by the server known as srv1: FOC ORDER=HDR,SDS,{CA},srv1</p>
TIMEOUT=	<p><i>value</i> Specifies the number of seconds to wait before initiating the failover process.</p> <p>The TIMEOUT parameter applies only after the value of EVENT_TIMEOUT is exceeded. For example, assume that the EVENT_TIMEOUT parameter is set to 60 and the failover timeout value is set to 10. If the Connection Manager does not receive any events from the primary server for 60 seconds, another 10 seconds must elapse before failover processing begins. See "Failover Configuration Examples" on page 11-16 for more information.</p>
RETRY=	<p><i>value</i> Specifies the number of times to go through the ORDER list while waiting for a successful failover to complete. Setting a value of 0 indicates that the Connection Manager should continue retrying failover processing indefinitely: After the RETRY limit has been reached without a successful failover, an alarm is generated and the Connection Manager terminates the automated failover attempt.</p>

INFORMIXSERVER server_list

Specifies an IBM Informix server or a list of servers to connect with during initialization of the Connection Manager. If the first server in the list is inoperative, then the Connection Manager attempts to connect to the next

server in the list, and so on until the end of the list is reached. You can use a macro for the server list of a comma-separated server list as in the following:

```
INFORMIXSERVER ${NYservers}
```

Group_type connection_unit_name

A connection unit is a specific high-availability server configuration. You specify connection units in your Connection Manager configuration file to direct client connection requests to the appropriate database server. Specify the *Group_type* as one of the following:

- CLUSTER
- GRID
- REPLSET
- SERVERSET

The *connection_unit_name* specifies the name by which the connection unit is known to the Connection Manager. Each *connection_unit_name* name must be unique within the configuration file.

When specifying the name of a CLUSTER connection unit in the configuration file, you should use the same name as the group name for the corresponding cluster in the INFORMIXSQLHOSTS file.

When specifying connection unit names in the configuration file, you can use multibyte characters only for GRID and REPLSET connection unit types.

LOG *log_errors*

Specifies whether to log information about PROXY and REDIRECT modes.

- LOG=1 logs information about both PROXY and REDIRECT service level agreements.
- LOG=2 or LOG=3 logs PROXY mode information only.
- LOG=2 logs data communication between the client and the server.
- LOG=3 logs data communication between the client and the server, and logs the data buffer.

LOGFILE *log_file_path_and_file_name*

Specifies the name and location of the Connection Manager log file. The log file is continuously updated with status information as long as the Connection Manager is running. The log file is necessary for monitoring and troubleshooting purposes. Make sure that the directory for the log file exists, and that access to the file is enabled for the user starting the Connection Manager. If no log file is specified, the Connection Manager creates a new file based on the Connection Manager name and the process ID. The path and file name of the log file are displayed when the Connection Manager is started.

MACRO *macro_name=(macro_list)*

Specifies the name of a macro and a list of server names. The macro name expands to the list of server names when used elsewhere in the configuration file. For example, the following line defines a macro named CA that consists of three servers:

```
MACRO CA=(ca1,ca2,ca3)
```

To use the macro, enclose the macro name in braces as shown here:

```
SLA repl1_ca DBSERVERS=${CA}
```

NAME *cm_name* (Mandatory)

Specifies the name of the Connection Manager instance. If the NAME parameter is not specified, the name of the first SLA is used as the Connection Manager instance name. You use *cm_name* to monitor the instance and to shut down or reload the Connection Manager. If more than one Connection Manager instance is configured, the name of each instance must be unique.

SECONDARY_EVENT_TIMEOUT=*timeout_value*

Specifies the amount of time, in seconds, that the Connection Manager waits for events from a secondary server before assuming the server has failed. If the Connection Manager receives no events from a secondary server during the time specified, the Connection Manager disconnect from the secondary server.

SLA *SLA_name SLA_attribute=SLA_value*

Specifies the service level agreement (SLA) name, redirection policy, and redirection type. Use the *SLA_name* parameter to specify the name of the SLA. The redirection policy specifies the type or the name of the target database server to which the client connects. Client applications use the SLA name to connect to the appropriate database server. The SLA parameter can be specified multiple times in the same configuration file; however, each SLA name must be unique. See "Service Level Agreement Examples" on page 11-12.

Each SLA must have a corresponding entry in the `sqlhosts` file. For each SLA, a listener thread is installed at the specified port on the server to detect incoming client requests. The Connection Manager connects clients to the appropriate database server according to the redirection policy.

Table 11-3. SLA parameters

Attribute	Value
DBSERVERS=	SDS Specifies an SD (Shared Disk) secondary server type.
	HDR Specifies an HDR (High-Availability Data Replication) secondary server type.
	RSS Specifies an RS (Remote Standalone) secondary server type.
	ANY Specifies any available Informix database server.
	PRI or primary Specifies the primary server.
	<i>server_name</i> or <i>server_alias</i> Specifies the name or alias name of a specific server.
#{macro}	The DBSERVERS parameter is specified using a comma-separated list of servers or server alias names, a server type, or a previously defined macro.

Table 11-3. SLA parameters (continued)

Attribute	Value
USEALIASES=	<p>OFF Specifies that the Connection Manager should redirect clients to servers specified by the DBSERVERS attribute, but not to aliases defined for those servers.</p> <p>The USEALIASES attribute accepts one value: OFF. When the Connection Manager connects to a database server, it records the server's DBSERVERNAME and DBSERVERALIASES configuration settings and network protocol types. If the USEALIASES attribute is omitted, the Connection Manager redirects clients to servers specified by the DBSERVERS attribute and also to any aliases that have a compatible network protocol.</p> <p>If the USEALIASES attribute is set to OFF, the Connection Manager redirects clients only to servers specified by the DBSERVERS attribute.</p> <p>For example, suppose that database server <i>srv1</i> has aliases <i>srv1_alias1</i> and <i>svr1_alias2</i>, and your Connection Manager contains the following SLA definitions:</p> <pre>SLA sla1 DBSERVERS=srv1 SLA sla2 DBSERVERS=srv1 USEALIASES=off SLA sla3 DBSERVERS=rv1_alias1 SLA sla4 DBSERVERS=rv1_alias1 USEALIASES=off</pre> <p>Given the previous configuration, the Connection Manager directs clients according to the following list:</p> <p>SLA Servers to which clients might be directed</p> <p>sla1 <i>srv1, srv1_alias1, srv1_alias2</i></p> <p>sla2 <i>srv1</i></p> <p>sla3 <i>srv1, rv1_alias1, rv1_alias2</i></p> <p>sla4 <i>rv1_alias1</i></p> <p>The attribute and the value are not case sensitive.</p> <p>For information about configuring server aliases, see "DBSERVERALIASES configuration parameter" on page 1-44.</p>
HOST=	<p><i>hostname</i> Specifies a particular host or host alias name.</p> <p><i>TCP/IP_address</i> Specifies a TCP/IP address.</p>

Table 11-3. SLA parameters (continued)

Attribute	Value
<p>MODE=</p>	<p>Specifies how Connection Manager redirects client connection requests.</p> <p>PROXY Specifies that client connections are to use proxy mode when clients connect to Informix database servers from outside a firewall. Setting proxy mode causes the Connection Manager to manage client communication with the appropriate server. Use proxy mode when the server is situated behind a firewall that the client would not ordinarily be able to connect to. Because the Connection Manager handles all client requests, consider configuring multiple Connection Manager instances when using proxy mode.</p> <p>REDIRECT Specifies that client connections to use redirect mode, which configures the Connection Manager to return the appropriate server node, IP address, and port number to the client application (depending on the SLA definition). The client application connects to the server using the IP address and port number that the Connection Manager provides.</p>
<p>NETTYPE=</p>	<p>onsoctcp Specify sockets with TCP/IP protocol.</p> <p>drsotcp Specifies Distributed Relational Database Architecture (DRDA) - connection for IBM data server client.</p> <p>onsocssl Specifies Secured Sockets Layer (SSL) protocol for DRDA.</p> <p>By default, the Connection Manager reads network configuration data from the \$INFORMIXSQLHOSTS file; however, you can specify network information in the Connection Manager configuration file without having to modify the \$INFORMIXSQLHOSTS file.</p>

Table 11-3. SLA parameters (continued)

Attribute	Value
<p>POLICY=</p>	<p>LATENCY Specifies that the Connection Manager will direct connection requests to the server with the lowest latency.</p> <p>FAILURE Specifies that connection requests will be routed to the server with the fewest apply failures.</p> <p>WORKLOAD Specifies that connection requests will be directed to the server with the lowest workload.</p> <p>The POLICY parameter specifies how the Connection Manager prioritizes client connection requests. The policy function uses a formula to decide which server to direct clients; the server with the best value is used. The policy refers to a relative value rather than an absolute value. For example, specifying LATENCY does not indicate a specific latency period.</p> <p>To select the server with the lowest latency and the fewest apply failures, making the LATENCY option 10 times more important than the FAILURE option, use: POLICY=10*LATENCY+FAILURE</p> <p>To use the LATENCY and FAILURE policies, you must have created a table through the grid with replication enabled.</p> <p>Quality of data monitoring must be enabled to use the POLICY parameter. See Routing client connections in a grid (Enterprise Replication).</p>
<p>SERVICE=</p>	<p><i>port_number</i> Specifies a port number</p> <p><i>servicename</i> Specifies a service name</p>
<p>SQLHOSTSOPT=</p>	<p>Specifies optional connectivity information. Enclose optional parameters in quotation marks.</p> <p>For example, suppose you wanted the following SQLHOSTS options configured in your SLA:</p> <pre># server nettype hostname servicename options informix1 onsoctcp host_1 sales_1 csm=cspath</pre> <p>You can specify the same parameters in your SLA using the following SLA definition:</p> <pre>SLA o1tp1 DBSERVERS=informix1 \ NETTYPE=onsoctcp \ HOSTNAME=host_1 \ SERVICE=sales_1 \ SQLHOSTSOPT="csm=cspath"</pre> <p>See sqlhosts Connectivity information (Administrator's Guide) for more information.</p>

Table 11-3. SLA parameters (continued)

Attribute	Value
WORKERS=	<i>value</i> Specifies the number of threads allocated to the SLA. When a service level agreement is specified, the Connection Manager creates an SLA listener process to intercept client connection requests. The SLA listener process can have one or more threads, called worker threads. If WORKERS is not specified, the number of worker threads assigned is 4. To set the number of worker threads to 8, set the following: WORKERS=8

SLA_WORKERS

Specifies the number of worker threads. When a service level agreement is specified, the Connection Manager creates an SLA listener process to intercept client connection requests. The SLA listener process can have one or more threads, called worker threads. If the **SLA_WORKERS** parameter is not specified, the number of worker threads assigned is 8.

SQLHOSTS *option*

Specify **SQLHOSTS local**, **SQLHOSTS remote**, or **SQLHOSTS local+remote**. When the Connection Manager receives a client connection request, it searches for the requested server based on the list of server instances defined in the `sqlhosts` file located on the Connection Manager instance. You can use the **SQLHOSTS** parameter to cause the Connection Manager to search for database instances on servers other than those listed in the `sqlhosts` file on the Connection Manager server instance.

For example, assume you have a web server located on an external network and an application server located on an internal network. The database server defines TCP/IP port1 and port2 for external network connections and TCP/IP port3 and port4 for internal connections. Specifying **SQLHOSTS local** causes the Connection Manager to find server instances defined only in the `sqlhosts` file of the Connection Manager instance. In this case, the Connection Manager directs client connection requests only to servers on the external network.

Specifying **SQLHOSTS remote** causes the Connection Manager to find server instances defined in the `sqlhosts` file of the primary server instance. Specifying **SQLHOSTS local+remote** causes the Connection Manager to direct connection requests to servers defined in the `sqlhosts` files of both the Connection Manager instance and the primary server instance.

The **SQLHOSTS** option is useful when you want to prevent users from accessing one or more servers in the cluster.

Table 11-4. Values for the SQLHOSTS Connection Manager configuration parameter

SQLHOSTS parameter	Result
local	The Connection Manager searches for the requested instance in the sqlhosts file located on the computer on which the Connection Manager is running. The Connection Manager uses the value set by the INFORMIXSQLHOSTS environment variable to determine which sqlhosts file to use; Informix instances are specified by the DBSERVERNAME or DBSERVERALIASES configuration parameters.
remote	The Connection Manager searches for the requested instance in the sqlhosts file located on a remote instance. The Connection Manager uses the value set by the INFORMIXSQLHOSTS environment variable to determine which sqlhosts file to use. Informix instances are specified by the DBSERVERNAME or DBSERVERALIASES configuration parameters.
local+remote	The Connection Manager first checks the local sqlhosts file for Informix instances; if the requested server entry is not found then the DBSERVERNAME or DBSERVERALIASES configuration parameters on the remote server are used.

Service Level Agreement Examples

The examples in this section show how to configure SLAs for high-availability clusters, replicate sets, grids, and server sets.

High-availability cluster examples

In each of the following examples, it is possible to use specific server alias names or generic server types. For example, specifying the keyword **RSS** indicates a generic server type, which means that the Connection Manager evaluates every RS secondary server in the cluster to determine the best candidate for client applications requests. You can also refer to a specific server by specifying its alias, such as *sds1*, or *rss1*.

The following examples show how the configuration file should appear. If the configuration file was named `cm_config`, you would start the Connection Manager by typing the following at a command prompt:

```
oncmsm -c cm_config
```

Example 1:

This example configures the Connection Manager for a high-availability cluster and defines two service level agreements. The heading of the configuration file defines the name, `cm1`, specifies that logging is to occur, and specifies the path and file name of the log file. The body of the configuration file defines two SLAs. The first SLA directs client connection requests such as `connect to @oltp` to the primary server. The second SLA directs connection requests such as `connect to @report` to the HDR secondary server or, if the HDR secondary server is not available, to any available SD secondary server.

```
NAME      cm1
LOG       1
LOGFILE   ${INFORMIXDIR}/tmp/cm1.log
```

```
CLUSTER west # cluster name
{
```

```

INFORMIXSERVER ids_w1,ids_w2
SLA oltp DBSERVERS=primary
SLA report DBSERVERS=(HDR,SDS)
FOC ORDER=SDS,HDR TIMEOUT=5 RETRY=1
CMALARMPROGRAM ${INFORMIXDIR}/etc/CMALARMPROGRAM.sh
}

```

Example 2:

This example configures the Connection Manager to resolve a client request such as: connect to @secondaryNodes by connecting to one of the SD secondary servers. If no SD secondary servers exist, then the Connection Manager attempts to direct the connection to the HDR secondary server. If the HDR secondary server is inoperative, then the Connection Manager attempts to connect to the primary server.

```

NAME      cm1
LOG        1
LOGFILE    ${INFORMIXDIR}/tmp/cm1.log

CLUSTER west # cluster name
{
  INFORMIXSERVER ids_w1,ids_w2
  SLA secondaryNodes DBSERVERS=SDS,HDR,primary
  FOC ORDER=SDS,HDR TIMEOUT=5 RETRY=1
  CMALARMPROGRAM ${INFORMIXDIR}/etc/CMALARMPROGRAM.sh
}

```

Example 3:

To enable load balancing among servers, use parentheses around server names or server types. In this example, the parentheses around SDS,HDR indicates that the connection could be routed to an SD secondary server or to the HDR secondary server based on which server has the lowest CPU utilization.

```

NAME      cm1
LOG        1
LOGFILE    ${INFORMIXDIR}/tmp/cm1.log

CLUSTER west # cluster name
{
  INFORMIXSERVER ids_w1,ids_w2
  SLA secondary DBSERVERS=(SDS,HDR)
  FOC ORDER=SDS,HDR TIMEOUT=5 RETRY=1
  CMALARMPROGRAM ${INFORMIXDIR}/etc/CMALARMPROGRAM.sh
}

```

Example 4:

In this example, assume that the primary server is assigned an alias name of **alpha**, the HDR secondary server has an alias of **beta**, and there are two SD secondary servers with aliases of **gamma1** and **gamma2**. The Connection Manager is started with three service level agreements, **sla1**, **sla2**, and **sla3**. Client connection requests sent to **sla1** are directed to the primary server using REDIRECT mode, meaning that the Connection Manager sends the IP address and port number of the primary server to the client application, which uses the information to connect to the server. Client connection requests sent to **sla2** are sent to the HDR secondary server (beta) using PROXY mode, which means that the Connection Manager is responsible for routing client requests. Connection requests sent to **sla3** are sent to one of the SD secondary servers (gamma1 or gamma2) based on which server has the most available resources.

```

NAME      cm1
LOG        1
LOGFILE   ${INFORMIXDIR}/tmp/cm1.log

CLUSTER west # cluster name
{
  INFORMIXSERVER ids_w1,ids_w2
  SLA sla1 DBSERVERS=alpha MODE=REDIRECT
  SLA sla2 DBSERVERS=beta MODE=PROXY
  SLA sla3 DBSERVERS=SDS
  FOC ORDER=SDS,HDR TIMEOUT=5 RETRY=1
  CMALARMPROGRAM ${INFORMIXDIR}/etc/CMALARMPROGRAM.sh
}

```

Start the Connection Manager from a command prompt using the following command:

```
oncmsm -c connectmgr
```

When the Connection Manager starts using the *connectmgr* configuration file, the following occurs:

- A Connection Manager instance named **cm1** is created.
- Four service level agreements, named **oltp**, **report**, **primary**, and **secondary** are created.
 - Client requests sent to SLA **oltp** are directed to the primary server using the Connection Manager as a proxy server.
 - Client requests sent to SLA **report** are directed to the first available SD secondary server; if no SD secondary servers are available, connections are sent to any available RS secondary server; if no RS secondary servers are available, then client requests are sent to the HDR secondary server.
 - Client requests sent to SLA **primary** are directed to the primary server.
 - Client requests sent to SLA **secondary** are directed to the secondary server that has the most resources available, regardless of whether the server is an SD secondary server, RS secondary server, or HDR secondary server.
- Client connection requests sent to **report**, **primary**, and **secondary** are directed to the appropriate server using REDIRECT mode. REDIRECT mode is the default if no mode is specified.
- Connection Manager creates a log file named /tmp/cm1.log.
- Debug mode is enabled.

Replicate set example

The following example shows the Connection Manager configuration file for an ER replicate set.

```

NAME      cm1
MACRO     NY=(ny1,ny2,ny3)
MACRO     CA=(ca1,ca2,ca3)
LOG        1
LOGFILE   ${INFORMIXDIR}/tmp/cm1.log

REPLSET erset #replset name
{
  INFORMIXSERVER g_er1,g_er2
  SLA repl1_any DBSERVERS=ANY # node discovery
  SLA repl1_ca DBSERVERS=${CA} \
    POLICY=WORKLOAD
  SLA repl1_ny DBSERVERS=${NY}
}

```

Grid example

This is an example configuration file for a grid.

```
NAME      cm1
MACRO    NY=(ny1,ny2,ny3)
MACRO    CA=(ca1,ca2,ca3)
LOG      1
LOGFILE  ${INFORMIXDIR}/tmp/cm1.log

GRID grid1 # grid name
{
  INFORMIXSERVER node1,node2,node3
  SLA grid1_any DBSERVERS=ANY POLICY=LATENCY
  SLA grid1_avail DBSERVERS=${NY},${CA}
}
```

Server set example

This example shows an example configuration to support a server set. The Connection Manager provides availability and load balancing of the servers specified in the SLA. The server set must be supported by the Connection Manager.

```
NAME      cm1
MACRO    NY=(ny1,ny2,ny3)
MACRO    CA=(ca1,ca2,ca3)
LOG      1
LOGFILE  ${INFORMIXDIR}/tmp/cm1.log

SERVERSET ss # name of serverset, unique in CM
{
  INFORMIXSERVER ids1,ids2,ids3
  SLA ssavail DBSERVERS=ids1,ids2,ids3 \
    HOST=apollo SERVICE=9600 NETTYPE=onsoctcp
  SLA ssany DBSERVERS=(ids1,ids2,ids3) \
    HOST=apollo SERVICE=9610 \
    NETTYPE=onsoctcp
}
```

Multiple connection unit example

This example shows how the Connection Manager is used to manage multiple connection units, including multiple high-availability clusters, replicate sets, grids, and server sets. The example configures the Connection Manager to support two high-availability clusters, a replicate set, two grids, and one server set.

```
NAME      cm1
MACRO    NY=(ny1,ny2,ny3)
MACRO    CA=(ca1,ca2,ca3)
LOG      1
LOGFILE  ${INFORMIXDIR}/tmp/cm1.log

CLUSTER west # cluster name (unique in CM)
{
  INFORMIXSERVER ids_w1,ids_w2
  SLA oltpw DBSERVERS=primary
  SLA reportw DBSERVERS=(HDR,SDS)
  FOC ORDER=SDS,HDR TIMEOUT=5 RETRY=1
  CMALARMPROGRAM ${INFORMIXDIR}/etc/CMALARMPROGRAM.sh
}
CLUSTER east # cluster name in CM
{
  INFORMIXSERVER ids_e1,ids_e2
  SLA oltpw DBSERVERS=primary
  SLA reporte DBSERVERS=RSS,HDR
```

```

FOC ORDER=HDR,RSS TIMEOUT=5 RETRY=1
CMALARMPROGRAM ${INFORMIXDIR}/etc/CMALARMPROGRAM.sh
}
REPLSET erset #replset name
{
  INFORMIXSERVER g_er1,g_er2
  SLA repl1_any DBSERVERS=ANY # node discovery
  SLA repl1_ca DBSERVERS=${CA} \
    POLICY=WORKLOAD
  SLA repl1_ny DBSERVERS=${NY}
}
GRID grid1 # grid name
{
  INFORMIXSERVER node1,node2,node3
  SLA grid1_any DBSERVERS=ANY POLICY=LATENCY
  SLA grid1_avail DBSERVERS=${NY},${CA}
}
GRID grid2 # grid name
{
  INFORMIXSERVER node4,node5
  SLA grid2_any DBSERVERS=ANY POLICY=LATENCY
  SLA grid2_avail DBSERVERS=${CA},${NY}
}
SERVERSET ss # name of serverset, unique in CM
{
  INFORMIXSERVER ids1,ids2,ids3
  SLA ssavail DBSERVERS=ids1,ids2,ids3 \
    HOST=apollo SERVICE=9600 NETTYPE=onsoctcp
  SLA ssany DBSERVERS=(ids1,ids2,ids3) \
    HOST=apollo SERVICE=9610 \
    NETTYPE=onsoctcp
}

```

Failover Configuration Examples

These examples show how to configure failover by using Connection Manager configuration files.

The following examples show several ways to configure Connection Manager to promote a secondary server to the primary server in the event the original primary server encounters a problem. Each SLA should have a failover configuration defined.

Example 1:

In this example, if the Connection Manager detects that the primary server is offline, then failover processing starts immediately because the timeout value is set to zero. The Connection Manager first attempts to convert the best available SD secondary server to the primary server; if no SD secondary servers are online, it attempts to convert the HDR secondary into the primary server; if that is not possible, it attempts to convert the most suitable RS secondary server to the primary server.

```
FOC ORDER=SDS,HDR,RSS TIMEOUT=0
```

Example 2:

In this example, setting the timeout value to 10 causes the Connection Manager to wait 10 seconds for the primary server to come back on line before starting failover processing. If the primary server does not come back online within the specified time, the Connection Manager attempts to convert any SD secondary server, any HDR secondary server, or any RS secondary server to the primary server.

```
FOC ORDER=SDS,HDR,RSS TIMEOUT=10
```

Example 3:

To specify a group of specific servers that can become the primary server, use alias names. In this example, the Connection Manager immediately performs a failover because the timeout value is not specified and is assumed to be 0. The Connection Manager attempts to fail over to the server with alias **hdrs1**; if **hdrs1** is not available, then it attempts to fail over to **sds1** if possible, and so on, trying **rss1**, **sds2**, and finally **rss2**.

```
FOC ORDER=hdrs1,sds1,rs1,sds2,rs2
```

Example 4:

In this example, if the Connection Manager is not able to determine within 20 seconds that the current primary server is online, then failover processing is started. The Connection Manager first attempts to convert the server with alias **sds1** to the primary server if possible; if not, then it attempts to convert the server with alias **hdrs1** to the primary server if possible; if not then the best SD secondary server is converted to the primary. The **RETRY** parameter indicates that the Connection Manager will go through the **ORDER** list a maximum of two times while waiting for a successful failover to complete. If failover does not complete after going through the **ORDER** list two times, an alarm is generated and the Connection Manager terminates failover.

Note that this failover configuration will not fail over to RS secondary servers because none are specified.

```
FOC ORDER=sds1,hdrs1,SDS TIMEOUT=20 RETRY=2
```

Proxy Mode and Redirect Mode

Use the **MODE=REDIRECT** or **MODE=PROXY** after the SLA definition to specify how the Connection Manager redirects client connection requests.

Specifying **MODE=REDIRECT** configures the Connection Manager to return the appropriate server node, IP address, and port number to the client application (depending on the SLA definition). The client application connects to the server using the IP address and port number that the Connection Manager provides. See Figure 11-1 on page 11-18.

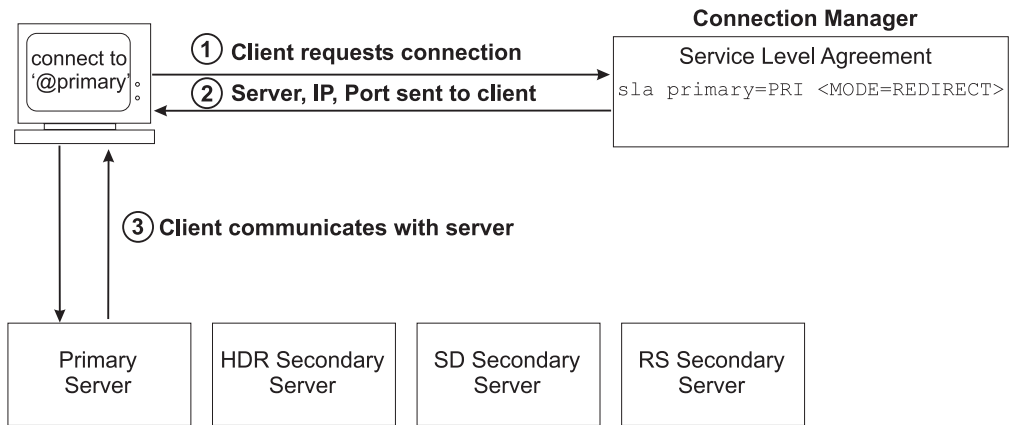

Figure 11-1. *MODE=REDIRECT* Service Level Agreement

Specifying **MODE=PROXY** configures the Connection Manager as a proxy server. Use **MODE=PROXY** when clients connect to Informix data servers from outside a firewall. Setting **MODE=PROXY** for a service level agreement causes the Connection Manager to manage client communication with the appropriate server. Use **MODE=PROXY** when the server is situated behind a firewall that the client would not ordinarily be able to connect to. Because the Connection Manager handles all client requests, consider configuring multiple Connection Manager instances when using **MODE=PROXY**. See Figure 11-2.

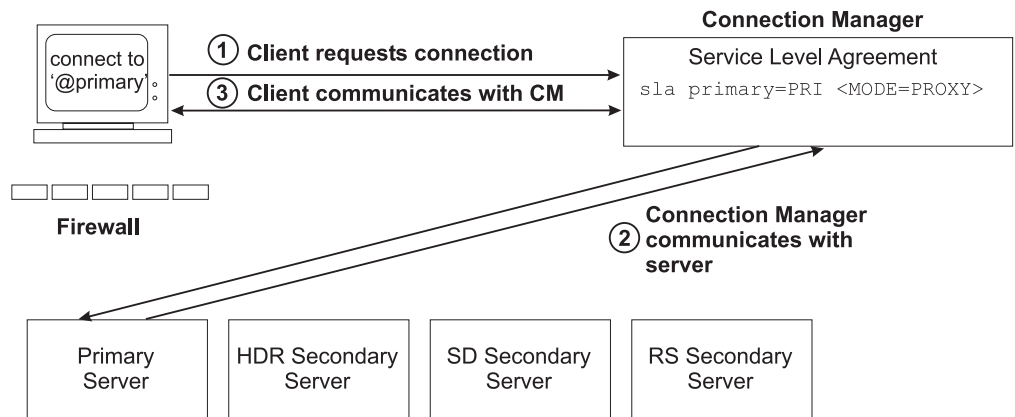

Figure 11-2. *MODE=PROXY* Service Level Agreement

Chapter 12. The ondblog Utility

In This Chapter

This chapter shows you how to use the ondblog utility.

ondblog: Change Logging Mode

Use the **ondblog** utility to change the logging mode for one or more databases.

Alternatively, you can change the logging mode by using an SQL administration API command with the **alter logmode** argument.

The **ondblog** utility logs its output in the BAR_ACT_LOG file.

If you turn on transaction logging for a database, you must create a level-0 backup of all of the storage spaces that contain data in the database before the change takes effect.

For more information and examples of logging modes, see the following topics in the chapter on managing database-logging status in the *IBM Informix Administrator's Guide*:

- Modifying the database-logging status
- Modifying table-logging status

You cannot use the ondblog utility on High-Availability Data Replication (HDR) secondary servers, remote standalone (RS) secondary servers, or shared disk (SD) secondary servers.

ondblog Syntax

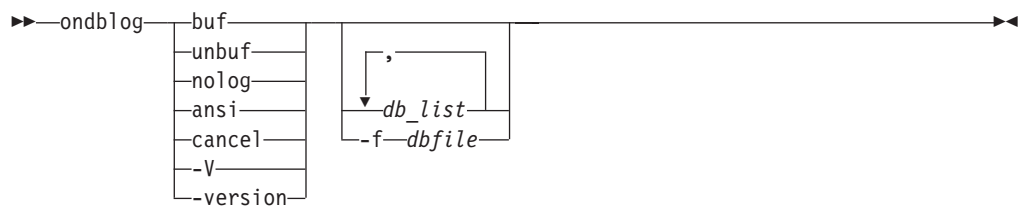

Element	Purpose	Key Considerations
buf	Sets the logging mode so that transaction information is written to a buffer before it is written to a logical log	None.
unbuf	Sets the logging mode so that data is not written to a buffer before it is written to a logical log	None.
nolog	Sets the logging mode so that no database transactions are logged	None.
ansi	Changes database logging to be ANSI compliant	Once you create or convert a database to ANSI mode, you cannot change it back to any of the other logging modes.

Element	Purpose	Key Considerations
cancel	Cancels the logging-mode change request before the next level-0 backup occurs	None.
-f <i>dbfile</i>	Changes the logging status of the databases that are listed (one per line) in the text file whose pathname is given by <i>dbfile</i>	This command is useful if the list of databases is long or used often.
<i>db_list</i>	Names a space-delimited list of databases whose logging status is to be changed	If you do not specify anything, all databases that the database server manages are modified.

Chapter 13. The oninit utility

The **oninit** utility starts the database server.

On UNIX, Linux, and Mac OS X, you must be logged in as user **root**, user **informix**, or the non-root database server owner to run the **oninit** utility. User **informix** should be the only member of the group **informix**. Run the **oninit** command from the command line. You can allow users who belong to the DBSA group to run the **oninit** command. See “Allow DBSA group users to run the oninit command (UNIX)” on page 13-4.

On Windows, IBM Informix runs as a Windows service. Any user who has appropriate permissions to start a Windows service is able to start the IBM Informix service. The **Services** control application runs the **oninit** utility with any options that you supply.

Syntax

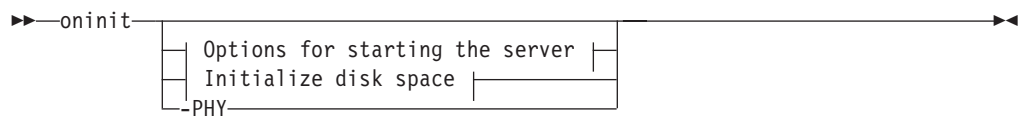

Options for starting the server:

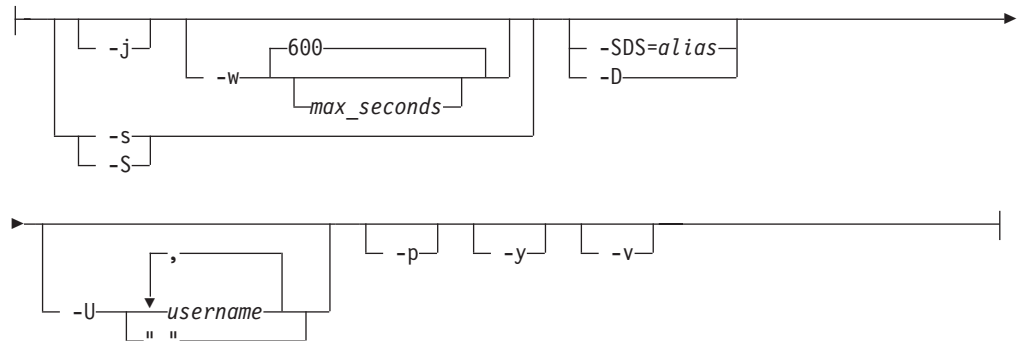

Initialize disk space:

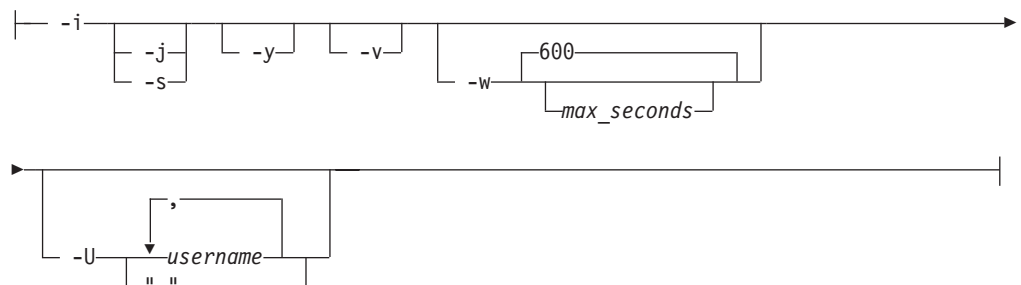

Element	Purpose	Key Considerations
-D	Starts the database server with Enterprise Replication and high-availability cluster replication disabled.	
-i	Initializes disk space for the root dbspace so that it can be used by the database server and starts the database server.	<p>Disk space needs to be initialized only once to prepare data storage for the server.</p> <p>By default, to prevent data loss, you cannot reinitialize disk space. To reinitialize disk space for an existing root dbspace, you must set the FULL_DISK_INIT configuration parameter to 1 and then run the oninit -i command.</p> <p>See “Initialize disk space for the root dbspace” on page 13-3.</p>
-j	Starts the server in administration mode.	See “Start the server in administration mode ” on page 13-3.
-p	Starts the database server without deleting temporary tables.	If you use this option, the database server starts more rapidly, but space used by temporary tables left on disk is not reclaimed.
-PHY	Starts the server as of most current checkpoint. The -PHY option is used to tell the server to do only physical recovery without logical recovery.	<p>This option is normally used to start a secondary server. You must run one of the following commands to connect the secondary server to the primary server:</p> <pre>onmode -d secondary onmode -d RSS</pre> <p>The connection of the secondary server to the primary server fails if the most recent checkpoint on the primary server was not performed on the secondary server.</p>
-s	Starts the server in quiescent mode.	<p>The database server must be shut down when you use this option.</p> <p>When the database server is in quiescent mode, only the user informix can access the database server.</p>
-S	Starts database server in quiescent mode as a standard server with high-availability data replication disabled.	When the database server is in quiescent mode, only the user informix can access the database server.
-SDS=<i>alias</i>	For shared disk servers, starts the current server and specifies the primary server with the alias name.	When both the primary server and all of the SDS servers are down, use the -SDS=<i>alias</i> option to start the designated SDS server as the primary server. The -SDS=<i>alias</i> flag cannot be combined with the -i flag.
-U <i>username</i>	Specifies which users can access the server in administration mode for the current session.	<p>The informix user and members of the DBSA group are always administration mode users.</p> <p>See “Start the server in administration mode ” on page 13-3.</p>
-v	Displays verbose informational messages while the server is starting.	
-w <i>max_seconds</i>	Starts the database server and waits to indicate success or failure until the server is completely started in online mode or the number of seconds specified by <i>max_seconds</i> elapses.	<p>The default number of seconds to wait is 600.</p> <p>This option is not valid on secondary servers in a high-availability cluster.</p> <p>See “Start the server with a script” on page 13-4.</p>

Element	Purpose	Key Considerations
-y	Prevents verification prompts.	The -y option automatically answers yes to all the verification prompts.

Usage

By default, the **oninit** utility shows verification prompts during server startup. You can suppress verification prompts by including the **-y** option. You can view verbose informational messages by including the **-v** option. On UNIX, Linux, and Mac OS X, **oninit** output is shown to standard output. On Windows, you can view **oninit** output by setting the **ONINIT_STOUT** environment variable to save the output to a file.

You can start the server in different operating modes. By default, if you run the **oninit** command without options, the server starts in online mode. When the database server is in online mode, all authorized users can access the server.

Start the server in administration mode

Administration mode is an administrator-only mode you can use to perform maintenance operations including those that require running SQL or DDL commands. When in administration mode, the database server only accepts connection requests from the following users:

- The **informix** user
- Members of the DBSA group
- Users specified by the **oninit -U** command or the **onmode -j -U** command, for the current session. The **-U** option overrides any users listed by the **ADMIN_MODE_USERS** configuration parameter in the **onconfig** file.
- Users specified by the **ADMIN_MODE_USERS** configuration parameter

Use the **-U** option with a list of comma-separated user names to add administration mode users, such as: **Karin,Sarah,Andrew**.

Use the **-U ""** option to remove all administration mode users except the **informix** user and members of the DBSA group: **oninit -U ""**.

Initialize disk space for the root dbspace

The first time you install IBM Informix on your system, disk space for the root dbspace for the database server needs to be initialized. The root dbspace is specified by the **ROOTPATH** configuration parameter.

If you performed a typical installation and chose to create a database server or you performed a customer installation, disk space was automatically initialized. Otherwise, you must initialize disk space by running the **oninit -i** command.

If necessary, you can reinitialize disk space. Reinitializing disk space destroys all existing data managed by the database server. The database server must be offline when you reinitialize.

By default, you cannot reinitialize a root dbspace that is being used by the database server. Disk initialization fails if a page zero exists at the root path location (at the first page of the first chunk location). You can allow disk

reinitialization of an existing root dbspace by setting the FULL_DISK_INIT configuration parameter to 1.

Start the server with a script

You can use the **oninit -w** command in customized startup scripts and to automate startup. The **-w** option forces the server to wait until startup is completely successfully before indicating that the server is in online mode by returning to the shell prompt with a return code of 0. If the server is not in online mode within the timeout period, the server returns a return code of 1 to the shell prompt and writes a warning message in the online log.

The default timeout is 600 seconds (10 minutes), which you can modify to any integer value.

After running the following command, if the server fails to start within 60 seconds, a code of 1 is returned to the prompt:

```
oninit -w 60
```

To determine the reason for the server failing to start, check the online log. You might need to increase the timeout value. When you use the **oninit -w** command in a script, you can check whether the server is online with the **onstat - (Print output header)** command.

Allow DBSA group users to run the oninit command (UNIX)

To allow users who belong to the DBSA group, other than the user **informix**, to run the **oninit** command, log in as the user **root** and change the permissions on the **oninit** utility in the \$INFORMIXDIR/bin directory from 6754 to 6755.

Related concepts:

 Database server operating modes (Administrator's Guide)

Related reference:

“ADMIN_MODE_USERS configuration parameter” on page 1-24

“FULL_DISK_INIT Configuration Parameter” on page 1-81

 Initialization process (Administrator's Guide)

Return codes for the oninit utility

If a **oninit** command encounters an error, the database server returns an error message and a return code value.

The following table contains the return codes, message text, and user actions for the **oninit** utility.

Table 13-1. Return codes for the oninit utility

Return Code	Message Text	User Action
0	The database server was initialized successfully.	The database server started.
1	Server initialized has failed. Look at any error messages written to stderr or the online message log.	Take the appropriate action based on the error messages written to stderr or the online message log.

Table 13-1. Return codes for the oninit utility (continued)

Return Code	Message Text	User Action
87	The database server has detected security violations or certain prerequisites are missing or incorrect.	(UNIX and Mac OS only) Check if user and group informix exists. Check if the server configuration file (onconfig) and sqlhosts file exists and has the correct permissions. Check if the environment variables INFORMIXDIR , ONCONFIG , and SQLHOSTS have a valid value and their length does not exceed 255 characters. Check if the environment variable INFORMIXDIR specifies an absolute path and does not have any spaces, tab, new lines, or other incorrect characters. Check if role separation-related subdirectories under the \$ INFORMIXDIR directory, such as aaodir and dbssodir , have the correct ownership. Run the onsecurity utility to diagnose and fix any issues.
170	The database server failed to initialize the dataskip structure.	Free some physical memory on the system and try to start the database server again.
172	The database server failed to initialize the listener threads.	Free some system resources, check the configuration parameter values for the number of listener threads to start when the database server starts up, and try to start the database server again.
173	The database server failed to initialize data replication.	Free some physical memory in the system and try to start the database server again.
174	The database server failed to start fast recovery threads.	Free some physical memory in the system and try to start the database server again.
175	The database server failed to initialize the root dbspace.	Check the root dbspace related parameters in server configuration file (onconfig) to make sure that the path for the root dbspace is valid.
176	Shared disk secondary server initialization failed.	Check the entries in sqlhosts file (UNIX) or SQLHOSTS registry key (Windows) to make sure that you are using the value of the DBSERVERNAME configuration for the primary server correctly. Check if the value for the SDS_PAGING configuration parameter in the server configuration file (onconfig) is correct. Free some system resources and try to start the database server again.
177	The database server failed to start the main_loop thread.	Free some physical memory on the system and try to start the database server again.
178	The database server failed to initialize the memory required for page conversion.	Free some physical memory on the system and try to start the database server again.
179	The database server was unable to start CPU VPs.	Free some physical memory on the system and try to start the database server again.
180	The database server was unable to start the ADM VP.	Free some physical memory on the system and try to start the database server again.
181	The database server failed to initialize kernel AIO.	Free some physical memory on the system and try to start the database server again.
182	The database server was unable to start IO VPs.	Free some physical memory on the system and try to start the database server again.
183	The database server failed to initialize the memory required for asynchronous I/O operations.	Free some physical memory on the system and try to start the database server again.
184	The database server failed to initialize memory required for parallel database queries. (PDQ)	Free some physical memory on the system and try to start the database server again.

Table 13-1. Return codes for the oninit utility (continued)

Return Code	Message Text	User Action
185	The database server failed to initialize various SQL caches.	Free some physical memory on the system and try to start the database server again.
186	The database server failed to initialize the Global Language Support (GLS) component.	Free some physical memory on the system and try to start the database server again.
187	The database server failed to initialize the Associated Service Facility (ASF) components.	Check the entries in sqlhosts file.
188	The database server was unable to start the CRYPTO VP.	Free some physical memory on the system and try to start the database server again.
189	The database server was unable to initialize the alarm program.	Free some physical memory on the system and try to start the database server again.
190	The database server failed to initialize the auditing component.	Free some physical memory on the system and try to start the database server again.
192	The database server failed to restore the Window station and desktop.	(Windows only) Try to shut down the database server after freeing some system resources.
193	The database server failed to create daemon processes.	(UNIX and Mac OS only) Free some system resources and try to startup the database server once again.
194	The database server failed to redirect the file descriptors properly.	(UNIX and Mac OS only) Check the availability of the /dev/null device and try to start the database server again.
195	The database server failed to initialize the current directory for use.	Check the validity of the current working directory from where the database server is being initialized.
196	The database server failed to initialize the /dev/null device.	(AIX only) Check the validity of the /dev/null device.
197	The database server failed to find the password information for the user trying to initialize the database server.	Verify that the user password is valid.
198	The database server failed to set the resource limits.	(UNIX and Mac OS only) Verify, and if required, increase the resource limits for processes on the host computer.
200	The database server did not have enough memory to allocate structures during initialization.	Free some physical memory on the system and try to start the database server again.
206	The database server could not allocate the first resident segment.	Check the values of the BUFFERPOOL and LOCKS configuration parameters in the server configuration file (onconfig) to make sure that they can be accommodated with the available memory on the host computer.
207	The database server failed to initialize shared memory and disk space.	Free some physical memory in the system, check the validity of all the chunks in the database server, and try to start the database server again.
208	The database server failed to allocate structures from shared memory.	Free some system resources and try to start the database server again.
209	The database server encountered a fatal error during the creation of shared memory.	Free some physical memory in the system and try to start the database server again.
210	The database server requested memory for the resident segment that exceeded the maximum allowed.	Reduce the size of the resident segment by lowering the values of the BUFFERPOOL and LOCKS configuration parameters.
220	The database server failed to read the audit configuration file.	Check that the audit configuration file (adtcfg) exists and is valid.

Table 13-1. Return codes for the oninit utility (continued)

Return Code	Message Text	User Action
221	The database server could not detect the default directory for DUMPPDIR. Usually it is the \$INFORMIXDIR/tmp directory.	Create the \$INFORMIXDIR/tmp directory if it is not present.
222	The database server detected an error in the value of the DBSERVERALIASES configuration parameter in the server's configuration file.	Verify that the values for the DBSERVERALIASES configuration parameter are valid and they have corresponding entries in the sqlhosts file (UNIX) or SQLHOSTS registry key (Windows).
223	The database server detected an error with the value of the DBSERVERNAME configuration parameter in the server's configuration file.	Verify that the value of the DBSERVERNAME configuration parameter is valid and it has a corresponding entry in the sqlhosts file (UNIX) or SQLHOSTS registry key (Windows).
224	The database server detected an error with the value of the HA_ALIAS configuration parameter in the server's configuration file.	Correct the value of the HA_ALIAS configuration parameter in the server configuration file (onconfig).
225	The database server detected too many entries for the NETTYPE configuration parameter or the DBSERVERALIASES configuration parameter in the server's configuration file.	Reduce the number of instances of the NETTYPE or DBSERVERALIASES configuration parameters in server configuration file (onconfig) and try to start the database server again.
226	The database server could not find an entry for the DBSERVERNAME configuration parameter in the sqlhosts file or the contents of the sqlhosts file are not valid.	Check the entries in the sqlhosts file.
227	Incorrect serial number.	Reinstall the database server.
228	The user does not have the necessary DBSA privileges to invoke the executable.	The user must have DBSA privileges or be a part of the Informix-Admin group (Windows).
229	The database server could not initialize the security sub-system.	(Windows only) The user does not the necessary user rights on the host or is not part of the Informix-Admin group.
230	The database server, if started as a process on Windows platform , timed out while trying to build the required system databases during initialization. (Windows only)	Check the event log on the host to determine why the service could not be opened or could not be started. The database server might have timed out while trying to build the system databases. Free some system resources and try to start the database server again.
231	Informix service startup failed when the "oninit -w" command was run as a process on the command line.	(Windows only) Check the event log on the host to determine why the service start has failed.
233	The database server failed to initialize the Pluggable Authentication Module (PAM).	Check the configuration for the PAM library on the system.
235	The database server detected errors for certain configuration parameter values in the server's configuration file.	Inspect the server configuration file (onconfig) for any errors.
236	The database server detected an error while trying to restrict the allowable values for the Informix edition in use.	Check if the SDS_ENABLE configuration parameter is set to 1 in the server configuration file (onconfig). Check if the server name specified with the oninit -SDS command matches the value of the HA_ALIAS or DBSERVERNAME configuration parameter. Check if the shared disk used is part of an existing shared disk cluster.
237	The database server could not find the server configuration file.	Ensure that the server configuration file exists and is valid.

Table 13-1. Return codes for the oninit utility (continued)

Return Code	Message Text	User Action
238	The database server detected an incorrect value for the INFORMIXSERVER environment variable or the value did not match the value of the DBSERVERNAME configuration parameter in the server's configuration file.	(Windows only) Check the value of the INFORMIXSERVER environment variable and the corresponding entry in the registry.
239	The database server detected an incorrect or non-existent value for the INFORMIXDIR environment variable.	(Windows only) Check the value of the INFORMIXDIR environment variable.
240	Incorrect command-line options were issued to the database server.	Correct the command-line options issued to the database server at startup.
248	The database server failed to create the Informix loader domain file.	(AIX only) Check if the /var/adm/ifx_loader_domain file is present.
249	The database server failed to dynamically load the PAM library.	The PAM library is not available for the database server. Install the PAM libraries.
250	The database server failed to dynamically load the ELF library.	The ELF library is not available to the database server. Install the libelf packages.
255	There was an internal error during server initialization. Look at any error messages written to stderr or to the online message log.	Take the appropriate action based on the error messages written to stderr or the online message log.

Chapter 14. The onlog Utility

The **onlog** utility displays the contents of a logical-log file, either on disk or on backup.

onlog: Display Logical-Log Contents

The **onlog** output is useful in debugging situations when you want to track a specific transaction or see what changes have been made to a specific tblspace. (For information about interpreting the logical-log file contents, see Chapter 5, “Interpreting Logical-Log Records,” on page 5-1.)

Any user can run all of the **onlog** options except the **-l** option. Only user **informix** on UNIX or a member of the **Informix-Admin** group on Windows can run the **-l** option.

If the database server is in offline mode when you execute **onlog**, only the files on disk are read. If the database server is in quiescent or online mode, **onlog** also reads the logical-log records stored in the logical-log buffers in shared memory (after all records on disk have been read).

When the database server reads a logical-log file with status U from disk while in online mode, the database server denies all access to the logical-log files, effectively stopping database activity for all sessions. (For more information, see “**onstat -l** command: Print physical and logical log information” on page 21-193.) For this reason, it is recommended that you wait until the files have been backed up and then read the contents of the logical-log files from backup.

The **onlog** utility does not have a functionally equivalent SQL administration API *command* string.

onlog Syntax

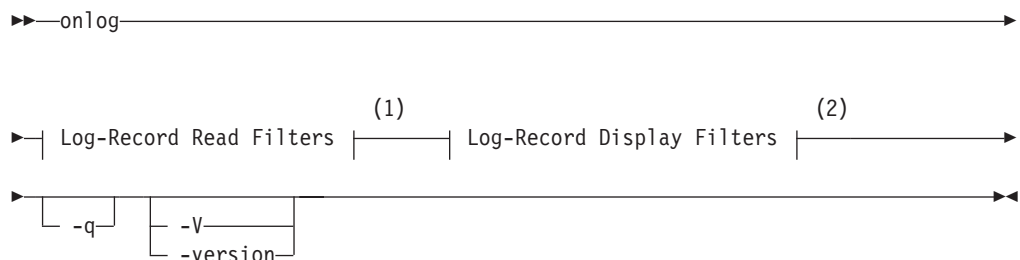

Notes:

- 1 see “Log-Record Read Filters” on page 14-2
- 2 see “Log-Record Display Filters” on page 14-3

Element	Purpose	Key Considerations
-q	Suppresses the initial header and the one-line header that appears every 18 records by default	None.

Element	Purpose	Key Considerations
-V	Displays the software version number and the serial number	See "Obtaining Utility Version Information" on page 6-1.
-version	Displays the build version, host, OS, number and date, as well as the GLS version	See "Obtaining Utility Version Information" on page 6-1.

You direct **onlog** to read the following portions of the logical log as it searches for records to display:

- Records stored on disk
- Records stored on backup media
- Records from the specified logical-log file

By default, **onlog** displays the logical-log record header, which describes the transaction number and the record type. The record type identifies the type of operation performed.

In addition to the header, you can use the read filters to direct **onlog** to display the following information:

- Logical-log record header and data (including copies of simple large objects stored in a dbspace or tblspace)
- Copies of blobpages from blobspaces
They are copied from the logical-log backup only. They are not available from disk.

You can display every logical-log record header, or you can specify output based on the following criteria:

- Records associated with a specific table
- Records initiated by a specific user
- Records associated with a specific transaction

If **onlog** detects an error in the log file, such as an unrecognizable log type, it displays the entire log page in hexadecimal format and terminates.

Log-Record Read Filters

The **onlog** utility uses the pathnames that are stored in the root dbspace reserved pages to locate the logical-log files. If you use ON-Bar to back up the logical logs, **onlog** asks the storage manager to retrieve the appropriate logical-log records from the backup media.

Syntax:

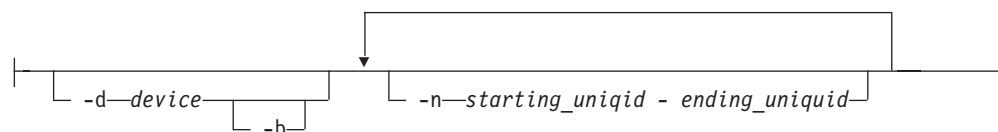

Element	Purpose	Key Considerations
-b	Displays logical-log records associated with blobSPACE blobpages	The database server stores these records on the logical-log backup media as part of blobSPACE logging.
-d device	Names the pathname of the storage device where the desired logical-log backup is mounted	<p>If you use ontape, the device that you name must be the same as the pathname of the device assigned to the configuration parameter LTAPEDEV. If the -d option is not used, onlog reads the logical-log files stored on disk, starting with the logical-log file with the lowest <i>logid</i>.</p> <p>If you use ON-Bar to back up logical logs, use the onbar -P command to view the contents of a logical-log file. See the <i>IBM Informix Backup and Restore Guide</i>.</p> <p>For pathname syntax, see your operating-system documentation.</p>
-n starting_uniqid- ending_uniqid	Directs onlog to read all the logical-log records contained in the log file that you specified from <i>starting_uniqid</i> to the <i>ending_uniqid</i> .	<p>The <i>starting_uniqid</i> and the <i>ending_uniqid</i> are the unique ID numbers of the logical log. To determine the <i>uniqid</i> of a particular logical-log file, use the onstat -l command.</p> <p>If you do not use the -n option, onlog reads all the logical-log files that are available (either on disk or on tape).</p> <p>For information about the onstat utility, see “Monitor the database server status” on page 21-18.</p>

Log-Record Display Filters

Syntax:

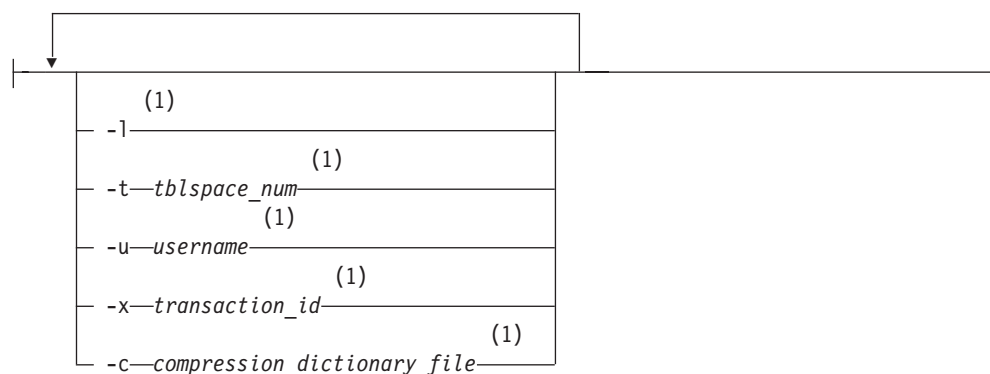

Notes:

- 1 Only one occurrence of this item allowed

Element	Purpose	Key Considerations
-l	Displays the long listing of the logical-log record.	The long listing of a log record includes a complex hexadecimal and ASCII dump of the entire log record. The listing is not intended for casual use.

Element	Purpose	Key Considerations
-tblspace_num	Displays records associated with the tblspace that you specify.	Unsigned integer. Number, greater than 0, must be in the partnum column of the systables system catalog table. Specify this value as either an integer or hexadecimal value. (If you do not use a 0x prefix, the value is interpreted as an integer.) To determine the tblspace number of a particular tblspace, query the systables system catalog table as described in “Tblspace Numbers” on page 4-5.
-u username	Displays records for a specific user.	User name must be an existing login name. User name must conform to operating-system-specific rules for login name.
-x transaction_id	Displays only records associated with the transaction that you specify.	Value must be an unsigned integer between 0 and TRANSACTIONS - 1, inclusive. You should need to use the -x option only in the unlikely case that an error is generated during a rollforward. When this situation occurs, the database server sends a message to the message log that includes the transaction ID of the offending transaction. You can use this transaction ID with the -x option of onlog to investigate the cause of the error.
-c <i>compression_dictionary_file</i>	Uses the compression dictionary to expand compressed data and display uncompressed data.	If the onlog command contains the -l option and the -c option and there are compressed images in the log records, the onlog utility uses the compression dictionary to expand all expandable images in the log records. A compressed image is expandable only if there is a valid compression dictionary for that log record in the compression dictionary file. If -c is not specified or the compression dictionary file does not contain a valid compression dictionary for the compressed image, the onlog utility will display the row image in its compressed format.

If you do not have a compression dictionary file, you can use an UNLOAD statement to unload the compression dictionary, which is contained in the **syscompdicts_full** table in the **sysmaster** database, to a compression dictionary file, as follows:

```
UNLOAD TO 'compression_dictionary_file'
  SELECT * FROM sysmaster:syscompdicts_full;
```

If you do not specify any options, **onlog** displays a short listing of all the records in the log. You can combine options with any other options to produce more selective filters. For example, if you use both the **-u** and **-x** options, **onlog** displays only the activities that the specified user initiated during the specified transaction. If you use both the **-u** and **-t** options, **onlog** displays only the activities initiated by the specified user and associated with the specified tblspace.

Related reference:

“alter logmode argument: Change the database logging mode (SQL administration API)” on page 22-20

Chapter 15. The onmode utility

Use the **onmode** utility to change the database server operating mode and perform various other operations on shared memory, sessions, transactions, parameters, and segments.

These topics show how to use the **onmode** options. If you do not use any options, the database server returns a usage statement.

On UNIX, you must be user **root** or user **informix** to run the **onmode** utility.

On Windows, you must be a member of the **Informix-Admin** group or the Administrators group to run the **onmode** utility.

For information on the **onmode -b** command, which is only used if you upgraded to a new version of Informix and need to revert your databases to the previous version of the server, see Syntax of the **onmode -b** command in the *IBM Informix Migration Guide*.

All **onmode** command options have equivalent SQL administration API *command* strings, except **onmode -b**, **onmode -BC**, and **onmode -R**.

onmode Syntax

Use **onmode** utility commands to perform various database server operations.

The following syntax diagram shows all of the options that you can use with the **onmode** command. The syntax diagram does not show all of the elements that you use with each command option. For the complete syntax of each command, see the topic on that command.

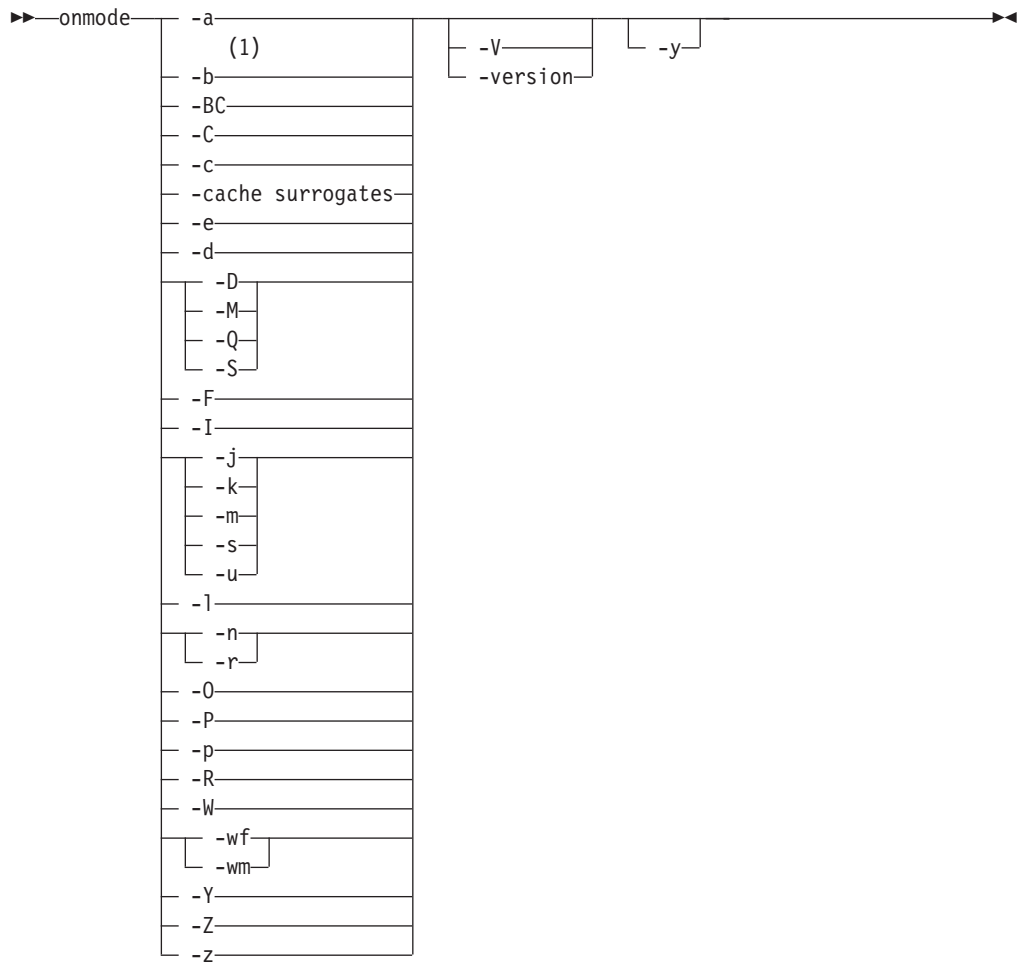

Notes:

- 1 For a description of the **onstat -b** command, see the *IBM Informix Migration Guide*.

Element	Purpose	Key Considerations
-y	Causes the database server to automatically respond yes to all prompts	None.
-V	Displays the software version number and the serial number	See "Obtaining Utility Version Information" on page 6-1.
-version	Displays the build version, host, OS, number and date, as well as the GLS version	See "Obtaining Utility Version Information" on page 6-1.

onmode -a: Add a shared-memory segment

Syntax



Element	Purpose	Key considerations
-a <i>seg_size</i>	Allows you to add a new virtual shared-memory segment. Size is specified in kilobytes	Restriction: The value of <i>seg_size</i> must be a positive integer. It must not exceed the operating system limit on the size of shared-memory segments.

Ordinarily, you do not need to add segments to the virtual portion of shared memory because the database server automatically adds segments as they are needed. However, as segments are added, the database server might reach the operating-system limit for the maximum number of segments before it acquires the memory that it needs. This situation typically occurs when the SHMADD configuration parameter is set so small that the database server exhausts the number of available segments before it acquires the memory that it needs for some operation.

You can use this command to add a segment that is larger than the size specified by the SHMADD configuration parameter. By using this command to add a segment, you can adhere to the operating system limit for segments while meeting the need that the database server has for additional memory.

This command has an equivalent SQL administration API function.

Related reference:

“add memory argument: Increase shared memory (SQL administration API)” on page 22-17

“onmode and a arguments: Add a shared-memory segment (SQL administration API)” on page 22-72

onmode -BC: Allow large chunk mode

Syntax:



Element	Purpose	Key Considerations
-BC 1	Enables support of large chunks, large offsets that are greater than 2 GB, and allows up to 32,768 chunks per instance.	This option allows large chunks to be created. Reversion without dropping the dbspace is possible if no chunks are larger than 2 GB. Dbspaces and blobspaces without chunks greater than 2 GB remain in the old format. After a chunk larger than 2 GB is added to a dbspace or blobspace then all chunks added or altered in that dbspace or blobspace are in the new format. See your <i>IBM Informix Administrator's Guide</i> .
-BC 2	Allows large-chunk-only mode for all dbspaces.	Reversion is not possible. Enables the 9.4 large chunk feature for all dbspaces and blobspaces, Any chunk or offset added or modified has the new format. Existing chunks that you do not alter remain in the old format. See your <i>IBM Informix Administrator's Guide</i>

The **onmode -BC** (backward-compatible) commands are useful if you have converted from Informix 9.40 (small chunk mode) to Informix 10.0 or later. When Informix 10.0 or later is first initialized (with the **oninit -iyv** command), by default

it comes online with large chunk mode already fully enabled. Reversion is not possible. In the case of a newly initialized instance of Informix 10.0 or later, the **onmode -BC** commands will return an error.

Note: After executing the **onmode -BC** command, perform a complete system level-0 backup.

onmode -c: Force a checkpoint

Syntax:

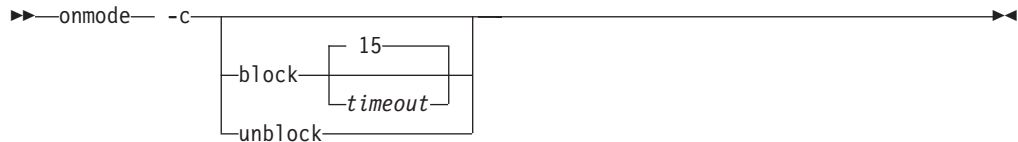

Element	Purpose	Key considerations
-c	Forces a checkpoint that flushes the buffers to disk.	You can use the -c option to force a sync checkpoint if the most recent checkpoint record in the logical log was preventing the logical-log file from being freed (status U-B-L).
block	Blocks the database server from any transactions.	While the database server is blocked, users can access it in read-only mode. Use this option to perform an external backup on IBM Informix. For more information, see the <i>IBM Informix Backup and Restore Guide</i> .
<i>timeout</i>	Specifies the number of seconds to wait for checkpoints to clear before returning to the command prompt.	The <i>timeout</i> option applies only if the DELAY_APPLY configuration parameter is configured (see “DELAY_APPLY Configuration Parameter” on page 1-53. If the DELAY_APPLY configuration parameter is enabled, the checkpoint requested by the primary server might not arrive at the secondary server for an extended period of time. It is also possible that no other checkpoints are staged in the staging directory. The default timeout value is 15 seconds and the maximum timeout allowed is 10 minutes (600 seconds). See <i>IBM Informix Backup and Restore Guide</i> .
unblock	Unblocks the database server.	When the database server is unblocked, data transactions and normal database server operations can resume. Use this option after you complete an external backup on IBM Informix. For more information, see the <i>IBM Informix Backup and Restore Guide</i> .

This command has an equivalent SQL administration API function.

Related reference:

“checkpoint argument: Force a checkpoint (SQL administration API)” on page 22-25

“onmode and c arguments: Force a checkpoint (SQL administration API)” on page 22-73

onmode -C: Control the B-tree scanner

Syntax:

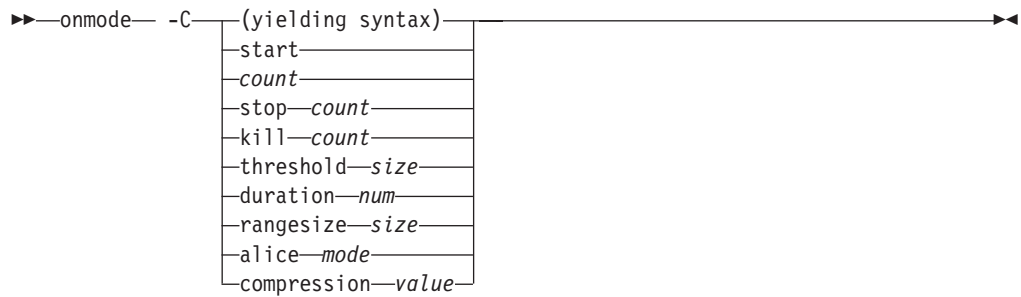

Element	Purpose	Key considerations
-C	Controls the B-tree scanner for cleaning indexes of deleted items	There is no limit to the number of threads that can run at one time. However, there is a limit of 128 threads that can be started at one time. If, for example, you wanted 150 threads to run, you could execute two commands: onmode -C 100 and onmode -C 50 .
start count	Starts additional B-tree scanner threads.	If <i>count</i> is not specified, a <i>count</i> of 1 is assumed. There is no limit on the number of scanner threads that can be specified.
stop count kill count	Stops B-tree scanner threads.	If <i>count</i> is not specified, a <i>count</i> of 1 is assumed. Stopping all index scanners prevents all index cleaning. Either of these commands stop the B-tree scanner.
threshold size	Sets the minimum number of deleted items an index must encounter before an index is placed on the hot list.	Once all indexes above the threshold have been cleaned and there is no other work for the B-tree scanner to do, the indexes below the threshold are added to the hot list.
duration num	The number of seconds that the hot list is valid.	After this number of seconds expires, the hot list will be rebuilt by the next available B-tree scanner thread, even if unprocessed items are on the list. Scanners currently processing requests are not interrupted.
rangesize size	Determines the size of an index before index range cleaning is enabled.	A size of -1 can be used to disable range scanning.
alice num	Sets the system's alice mode.	Valid <i>num</i> values range from 0 (OFF) to 12.
compression value	For a database server instance, modifies the level at which two partially used index pages are merged. The pages are merged if the data on those pages totals a set level.	Valid values for the level are low, med (medium), high, and default. The system default value is med.

The B-tree scanner has statistical information which tracks index efficiency and how much extra work the index currently places on the server. Based on the

amount of extra work the index has accomplished because of committed deleted index items, the B-tree scanner develops an ordered list of indexes that have caused the server to do extra work. This list is called the hot list. The index causing the highest amount of extra work is cleaned first and the rest of the indexes are cleaned in descending order. The DBA can allocate cleaning threads dynamically, thus allowing for configurable workloads.

This command has an equivalent SQL administration API function.

Related reference:

“onmode and C arguments: Control the B-tree scanner (SQL administration API)” on page 22-74

“set index compression argument: Change index page compression (SQL administration API)” on page 22-107

“BTSCANNER Configuration Parameter” on page 1-34

onmode -cache surrogates: Cache the allowed.surrogates file

Syntax:

▶▶ onmode — -cache surrogates —▶▶

Element	Purpose	Key considerations
-cache surrogates	Reads the /etc/informix/ allowed.surrogates file and stores the user IDs and group IDs values in shared memory cache. The user names and group names specified in allowed.surrogates file have to be valid operating system users and groups. The names are converted to corresponding UIDs and GIDs.	<p>You can use onmode -cache surrogates during a session to load the allowed.surrogates file. The allowed.surrogates file is used specify users and groups who can act as surrogates for mapped users. The allowed.surrogates file will be automatically checked before a new connection is made to the database server or when users are created or altered.</p> <p>If the cache-refresh fails, the existing surrogate cache is cleared, effectively disabling mapped users. Existing connections on the server will be unaffected by changes in shared-memory cache. Changes in shared memory cache affect new sessions.</p>

Related concepts:

➦ Mapped user surrogates in the allowed.surrogates file (UNIX, Linux) (Security Guide)

Related tasks:

➦ Specifying surrogates for mapped users (UNIX, Linux) (Security Guide)

Related reference:

➦ Surrogate user properties (UNIX, Linux) (SQL Syntax)

onmode -d: Set data-replication types

Syntax:

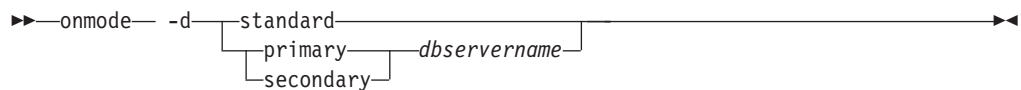

Element	Purpose	Key Considerations
-d	Used to set the High-Availability Data-Replication type, either standard, primary, or secondary, as the following sections describe	You can use the -d primary and -d secondary options only when the database server is in quiescent mode. You can use the -d standard option when the database server is in quiescent, online, or read-only mode.
<i>dbservername</i>	Identifies the database server name of the primary or secondary database server	<p>The <i>dbservername</i> argument must correspond to the DBSERVERNAME parameter in the ONCONFIG file of the intended secondary database server. It should <i>not</i> correspond to one of the database servers that the DBSERVERALIASES parameter specifies.</p> <p>The <i>dbservername</i> argument of the other database server in the data-replication pair and the type of a database server (standard, primary, or secondary) is preserved after reinitialization of shared memory.</p> <p>For more information, see <i>range of values</i> for the DBSERVERNAME configuration parameter in “DBSERVERNAME configuration parameter” on page 1-46.</p>

Related reference:

“ha set primary argument: Define an HDR primary server (SQL administration API)” on page 22-61

“ha set secondary argument: Define an HDR secondary server (SQL administration API)” on page 22-62

“ha set standard argument: Convert an HDR server into a standard server (SQL administration API)” on page 22-62

“onmode and d arguments: Set data-replication types (SQL administration API)” on page 22-75

Using the -d standard Option

The **-d standard** option drops the connection between database servers in a data replication pair (if one exists) and sets the database server type of the current database server to standard. This option does not change the mode or type of the other database server in the pair.

Use the **onmode -d standard** command only to disconnect a primary server from an HDR secondary server. Running the command converts the HDR secondary server to a standalone server. You should not run the **onmode -d standard** command to disconnect a primary server from an RS secondary server. To disconnect a primary server from an RS secondary server run the following commands:

On the primary server:

```
onmode -d delete RSS dbservername
```

On the RS secondary server:

```
onmode -d standard
```

Using the -d primary dbservername Option

The **-d primary *dbservername*** option sets the database server type to primary and attempts to connect with the database server that *dbservername* specifies. If the connection is successful, data replication is turned on. The primary database server goes into online mode, and the secondary database server goes into read-only mode. If the connection is not successful, the database server comes to on-line mode, but data replication is not turned on.

Using the -d secondary dbservername option

The **-d secondary *dbservername*** option sets the database server type to secondary and attempts to connect with the database server that *dbservername* specifies. If the connection is successful, data replication is turned on. The primary database server goes online, and the secondary database server goes into read-only mode. If the connection is not successful, the database server comes to read-only mode, but data replication is not turned on.

This command has an equivalent SQL administration API function. For more information see “SQL Administration API Overview” on page 22-1 and the *IBM Informix Administrator’s Guide*.

Element	Purpose	Key Considerations
<i>password</i>	Specifies the secondary server password	The password is used only during the first connection attempt. After the primary and secondary server have connected, the password cannot be changed.
RSS	Sets an RS secondary server type	This command should be run on the secondary database server.
<i>pri_server_name</i>	Identifies the name of the primary server	
change RSS	Change an RS secondary server	This command should be run on the primary database server.
delete RSS	Removes an RS secondary server definition	This command should be run on the primary database server.
set SDS primary	Defines the server as a shared disk primary server	
<i>server_name</i>	The name of the database server	When used with set SDS or make primary , this is the name of the server whose role is changing.
force	Used to force a change	If the force option is specified, the operation is performed without requiring that the secondary server be connected to the current primary server. If the force option is not specified, the operation must be coordinated with the current primary server. The force option should be used only when the DBA is certain that the current primary server is not active; otherwise, the shared disk subsystem can become corrupted.
clear SDS primary	Disables the shared disk environment. The server name specified no longer acts as an SD primary server	
make primary	Creates a primary server	The make primary command can be issued on any type of secondary server, including HDR secondary, RS secondary, and SD secondary servers. If make primary is run on: <ul style="list-style-type: none"> • HDR Secondary: The current primary server is shut down and the secondary is made the primary. • RS secondary: The server is changed to a standard server. • SD secondary: The server is made the new primary server.

You can also set data replication characteristics can with SQL administration API *command* equivalents. For more information see “SQL Administration API Overview” on page 22-1 and the *IBM Informix Administrator's Guide*.

For other **onmode -d** information, see “onmode -d: Set data-replication types” on page 15-7 and “**onmode -d** command: Replicate an index with data-replication” on page 15-11.

Related reference:

“ha make primary argument: Change the mode of a secondary server (SQL administration API)” on page 22-53

“ha rss argument: Create an RS secondary server (SQL administration API)” on page 22-54

“ha rss add argument: Add an RS secondary server to a primary server (SQL administration API)” on page 22-55

“ha rss change argument: Change the password of an RS secondary server (SQL administration API)” on page 22-56

“ha rss delete argument: Delete an RS secondary server (SQL administration API)” on page 22-57

“ha sds clear argument: Stop shared-disk replication (SQL administration API)” on page 22-57

“ha sds set argument: Create a shared-disk primary server (SQL administration API)” on page 22-59

“ha sds primary argument: Convert an SD secondary server to a primary server (SQL administration API)” on page 22-58

onmode -d command: Replicate an index with data-replication

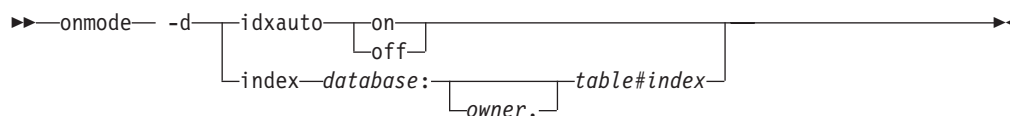
Syntax:

Element	Purpose	Key considerations
-d	Specifies how indexes are replicated to a High-Availability Data-Replication (HDR) secondary server when an index on the secondary server becomes corrupt	You can use the onmode -d idxauto and onmode -d index commands while the server is in online mode.
idxauto	Enables automatic index replication when an index on a secondary server becomes corrupt	Use the onmode -d idxauto command to overwrite the value of the DRIDXAUTO configuration parameter within a session. For more information on DRIDXAUTO, see “DRIDXAUTO Configuration Parameter” on page 1-58. For more information on replicating indexes, see the chapter on using High-Availability Data Replication in the <i>IBM Informix Administrator’s Guide</i> .
index	Replicates an index from a primary to a secondary server	If you detect a corrupt index on a secondary server, use the onmode -d index command to start replication of the index from the primary to the secondary server.
database	Specifies the database containing the index to replicate	Syntax must conform to the Identifier segment; see the <i>IBM Informix Administrator’s Guide</i> .
index	Specifies the name of the index to replicate	Index must exist on table and in database specified. Syntax must conform to the Identifier segment; see the <i>IBM Informix Administrator’s Guide</i> .

Element	Purpose	Key considerations
<i>owner</i>	Specifies the owner of a table	You must specify the current owner of the table. Syntax must conform to the Table Name segment; see the <i>IBM Informix Administrator's Guide</i> .
<i>table</i>	Specifies the name of the table on which the index is based	Syntax must conform to the Table Name segment; see the <i>IBM Informix Administrator's Guide</i> .

The **onmode -d idxauto** and the **onmode -d index** commands provide methods to replicate an index to a secondary server containing a corrupted index. The base table will be locked during the transfer of an index. The alternative to using these options is to drop and rebuild the corrupt index on the primary server.

In the case of a fragmented index with one corrupt fragment, the **onmode -d idxauto** command only transfers the single affected fragment, whereas the **onmode -d index** command transfers the whole index.

This command has an equivalent SQL administration API function. For more information see "SQL Administration API Overview" on page 22-1 and the *IBM Informix Administrator's Guide*.

For additional **onmode -d** command information, see "onmode -d: Set High Availability server characteristics" on page 15-9 and "onmode -d: Set data-replication types" on page 15-7.

Related reference:

"ha set idxauto argument: Replicate indexes to secondary servers (SQL administration API)" on page 22-60

onmode -D, -M, -Q, -S: Change decision-support parameters

Syntax:

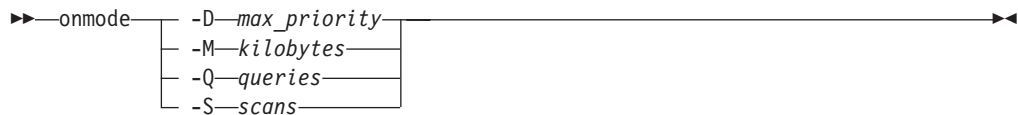

Element	Purpose	Key considerations
-D max_priority	Changes the value of MAX_PDQPRIORITY	This value must be an unsigned integer between 0 and 100. Specify <i>max_priority</i> as a factor to temper user requests for PDQ resources. For information on parameters used for controlling PDQ, see "MAX_PDQPRIORITY configuration parameter" on page 1-96 and the <i>IBM Informix Performance Guide</i> .

Element	Purpose	Key considerations
-M kilobytes	Changes the value of DS_TOTAL_MEMORY	<p>This value has a platform-dependent upper limit. If you enter a very large value and that value is too large for your platform, you will receive a message that gives you the range of values for your platform.</p> <p>Specify <i>kilobytes</i> for the maximum amount of memory available for parallel queries.</p> <p>For more information, see “DS_TOTAL_MEMORY configuration parameter” on page 1-64 and the <i>IBM Informix Performance Guide</i>.</p>
-Q queries	Changes the value of DS_MAX_QUERIES	<p>This value must be an unsigned integer between 1 and 8,388,608.</p> <p>Specify <i>queries</i> for the maximum number of concurrently executing parallel queries.</p> <p>For information on parameters used for controlling PDQ, see “DS_MAX_QUERIES configuration parameter” on page 1-61 and the <i>IBM Informix Performance Guide</i>.</p>
-S scans	Changes the value of DS_MAX_SCANS	<p>This value must be an unsigned integer between 10 and 1,048,576.</p> <p>Specify <i>scans</i> for the maximum number of concurrently executing parallel scans.</p> <p>For information on parameters used for controlling PDQ, see “DS_MAX_SCANS configuration parameter” on page 1-62 and the <i>IBM Informix Performance Guide</i>.</p>

These options allow you to change configuration parameters while the database server is online. The new values affect only the current instance of the database server; the values are not recorded in the ONCONFIG file. If you shut down and restart the database server, the values of the parameters revert to the values in the ONCONFIG file. For more information about these configuration parameters, see Chapter 1, “Database configuration parameters,” on page 1-1.

To check the current values for the MAX_PDQPRIORITY, DS_TOTAL_MEMORY, DS_MAX_SCANS, DS_MAX_QUERIES, and the DS_NONPDQ_QUERY_MEM configuration parameters, use **onstat -g mgm**. See “**onstat -g mgm** command: Print MGM resource information” on page 21-116.

This command has an equivalent SQL administration API function.

Related reference:

“onmode and D arguments: Set PDQ priority (SQL administration API)” on page 22-77

“onmode and M arguments: Temporarily change decision-support memory (SQL administration API)” on page 22-81

“onmode and Q arguments: Set maximum number for decision-support queries (SQL administration API)” on page 22-84

“onmode and S arguments: Set maximum number of decision-support scans (SQL administration API)” on page 22-86

onmode -e: Change usage of the SQL statement cache

Syntax:

►► onmode -e mode ◀◀

Element	Purpose	Key considerations
onmode -e ENABLE	Enables the SQL statement cache. For more information, see the material on improving query performance in the <i>IBM Informix Performance Guide</i> .	User sessions use the cache only when they perform either of the following actions: <ul style="list-style-type: none">• Set the environment variable STMT_CACHE to 1• Execute the SQL statement SET STATEMENT CACHE ON
onmode -e FLUSH	Flushes the statements that are not in use from the SQL statement cache	The onstat -g ssc ref_cnt field shows 0.
onmode -e OFF	Turns off the SQL statement cache	No statements are cached.
onmode -e ON	Turns on the SQL statement cache	All statements are cached unless the user turns it off with one of the following actions: <ul style="list-style-type: none">• Set the environment variable STMT_CACHE to 0• Execute the SQL statement SET STATEMENT CACHE OFF

The **onmode -e** changes are in effect for the current database server session only. When you restart the database server, it uses the default STMT_CACHE parameter value in the ONCONFIG file.

This command has an equivalent SQL administration API function.

Related reference:

“onmode and e arguments: Change usage of the SQL statement cache (SQL administration API)” on page 22-77

onmode -F: Free unused memory segments

Syntax:

►► onmode -F ◀◀

The diagnostics collection procedures are described in the *IBM Informix Administrator's Guide*.

onmode -k, -m, -s, -u, -j: Change database server mode

Syntax:



Element	Purpose	Key Considerations
-k	Takes the database server to offline mode and removes shared memory	To reinitialize shared memory, shut down and restart the database server. "Taking the Database Server to Offline Mode with the -k Option" on page 15-17.
-m	Takes the database server from quiescent or administration mode to online mode	See "Bringing the Database Server Online with the -m Option" on page 15-17.
-s	Shuts down the database server gracefully	Users who are using the database server are allowed to finish before the database server comes to quiescent mode, but no new connections are allowed. When all processing is finished, -s takes the database server to quiescent mode. The -s option leaves shared memory intact. See "Shutting Down the Database Server Gracefully with the -s Option" on page 15-17.
-u	Shuts down the database server immediately	This option brings the database server to quiescent mode without waiting for users to finish their sessions. Their current transactions are rolled back, and their sessions are terminated. See "Shutting Down the Database Server Immediately with the -u Option" on page 15-17.
-j	Puts the database server into administration mode	This option brings the database server to administration mode, allowing the informix user all functions including the issuance of SQL and DDL commands. The -j -U option enables the DBSA to designate specific users (in addition to the informix user) to access the database server. See your <i>IBM Informix Administrator's Guide</i> .

The following sections describe the options that take the database server from one mode to another.

Related reference:

“onmode and j arguments: Switch the database server to administration mode (SQL administration API)” on page 22-79

“onmode and m arguments: Switch to multi-user mode (SQL administration API)” on page 22-80

Taking the Database Server to Offline Mode with the -k Option

The **onmode -k** option takes the database server to offline mode and removes database server shared memory.

A prompt asks for confirmation. Another prompt asks for confirmation to kill user threads before the database server comes offline. If you want to eliminate these prompts, execute the **-y** option with the **-s** option.

This option does not kill all client sessions. Use the **-u** option to avoid hanging client sessions or virtual server processes.

Important: When you use the **onmode -k** command to shut down the database server, utilities that are waiting for a user response might not terminate. For example, **ontape** might be waiting for another tape, **onstat -i** might be waiting for a user response, or **onspaces** might be waiting for **y** or **n** to continue. If this problem occurs, use **onmode -uk** or **-uky** instead to roll back work before removing shared memory. For more information, see the descriptions of other options on this page.

Related reference:

Chapter 10, “The onclean Utility,” on page 10-1

“The onshutdown script” on page 10-2

Bringing the Database Server Online with the -m Option

The **-m** option brings the database server online from quiescent mode.

Shutting Down the Database Server Gracefully with the -s Option

The **-s** option causes a graceful shutdown. Users who are using the database server are allowed to finish before the database server comes to quiescent mode, but no new connections are allowed. When all processing is finished, **-s** takes the database server to quiescent mode. The **-s** option leaves shared memory intact.

A prompt asks for confirmation. If you want to eliminate this prompt, execute the **-y** option with the **-s** option.

Shutting Down the Database Server Immediately with the -u Option

The **-u** option causes immediate shutdown. This option brings the database server to quiescent mode without waiting for users to finish their sessions. Their current transactions are rolled back, and their sessions are terminated.

A prompt asks for confirmation. Another prompt asks for confirmation to kill user threads before the database server comes to quiescent mode. If you want to eliminate these prompts, execute the **-y** option with the **-s** option.

Changing the Database Server to Administration Mode with the -j Option

The **-j** option puts the database server into the administration mode and allows only the DBSA group and the user **informix** to connect to the server. The **-j** option allows a DBSA to have the server in a fully functional mode to perform maintenance.

The **-j -U** option enables the DBSA to grant individual users access to the database server in administration mode. Once connected, these individual users can execute any SQL or DDL command. When the server is changed to administration mode, all sessions for users other than user **informix**, the DBSA group users, and those identified in the **onmode -j -U** command lose their database server connection.

The following example enables three individual users to connect to the database server and have database server access until the database server mode changes to offline, quiescent or online mode:

```
onmode -j -U karin,sarah,andrew
```

Access for individual users can also be removed by executing **onmode -j -U** and removing their name from the new list of names in the command. For example, in the following commands, the first command grants only Karin access, the second command grants Karin and Sarah access, and the third command grants only Sarah access (and removes access from Karin).

```
onmode -j -U karin
onmode -j -U karin,sarah
onmode -j -U sarah
```

To allow user **informix** and the DBSA group user to retain their database server access in administration mode and remove all single users from accessing the database server, use the following command:

```
onmode -j -U ' '
```

For information on designating single users in administration mode using a configuration parameter, see “ADMIN_MODE_USERS configuration parameter” on page 1-24

Related reference:

“ADMIN_MODE_USERS configuration parameter” on page 1-24

Changing Database Server Mode with ON-Monitor (UNIX)

You can also use ON-Monitor options to change the database server mode. The following table shows ON-Monitor options that are equivalent to the **onmode** options.

onmode Option	ON-Monitor Option
-k	Take-Offline
-m	On-Line
-s	Graceful-Shutdown
-u	Immediate-Shutdown
-j	Administration Mode

onmode -l: Switch the logical-log file

Syntax:

►► onmode -l ◀◀

Element	Purpose	Key considerations
-l	Switches the current logical-log file to the next logical-log file	You must use onmode to switch to the next logical-log file. For information on switching to the next logical-log file, see the chapter on managing logical-log files in the <i>IBM Informix Administrator's Guide</i> .

This command has an equivalent SQL administration API function.

Related reference:

"onmode and l arguments: Switch to the next logical log (SQL administration API)" on page 22-80

onmode -n, -r: Change shared-memory residency

Syntax:

►► onmode [-n] [-r] ◀◀

Element	Purpose	Key considerations
-n	Ends forced residency of the resident portion of shared memory	This command does not affect the value of RESIDENT, the forced-residency parameter in the ONCONFIG file.
-r	Starts forced residency of the resident portion of shared memory	This command does not affect the value of RESIDENT, the forced-memory parameter in the ONCONFIG file.

Important: Set the RESIDENT parameter to 1 before you use the **onmode -r** or **-n** options.

For information on using the forced-residency parameter to turn residency on or off for the next time that you restart the database server, see the chapter on managing shared memory in the *IBM Informix Administrator's Guide*.

This command has an equivalent SQL administration API function.

Related reference:

“onmode and n arguments: Unlock resident memory (SQL administration API)” on page 22-82

“onmode and r arguments: Force residency of shared memory (SQL administration API)” on page 22-85

onmode -O: Override ONDBSPACEDOWN WAIT mode

Syntax:

► onmode -O ◀

Element	Purpose	Key considerations
-O	Overrides the WAIT mode of the ONDBSPACEDOWN configuration parameter	None.

Use the **onmode -O** option only in the following circumstances:

- ONDBSPACEDOWN is set to WAIT.
- A disabling I/O error occurs that causes the database server to block all updating threads.
- You cannot or do not want to correct the problem that caused the disabling I/O error.
- You want the database server to mark the disabled dbspace as down and continue processing.

When you execute this option, the database server marks the dbspace responsible for the disabling I/O error as down, completes a checkpoint, and releases blocked threads. Then **onmode** prompts you with the following message:

```
This will render any dbspaces which have incurred disabling I/O errors unusable
and require them to be restored from an archive.
Do you wish to continue?(y/n)
```

If **onmode** does not find any disabling I/O errors on noncritical dbspaces when you run the -O option, it notifies you with the following message:

```
There have been no disabling I/O errors on any noncritical dbspaces.
```

This command has an equivalent SQL administration API function.

Related reference:

“onmode and O arguments: Mark a disabled dbspace as down (SQL administration API)” on page 22-82

onmode -p: Add or remove virtual processors

Use the **onmode -p** command to dynamically add or remove virtual processors for the current database session. The **onmode -p** command does not update the onconfig file.

Syntax:

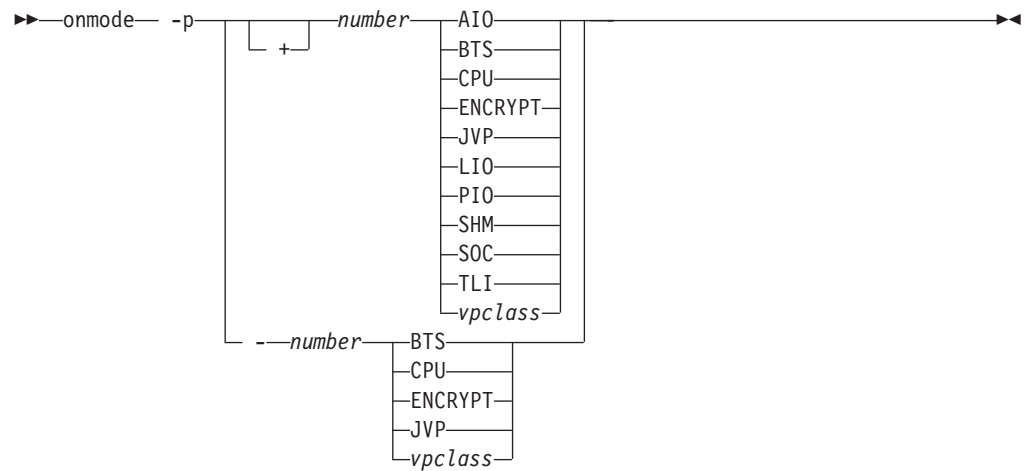

Element	Purpose	Key Considerations
<code>-p number</code>	<p>Adds or removes virtual processors. The <i>number</i> argument indicates the number of virtual processors to add or remove</p> <p>If this value is a negative integer, processors are removed. If this value is a positive integer, processors are added.</p>	<p>You can use the <code>-p</code> option only when the database server is in online mode, and you can add to only one class of virtual processors at a time.</p> <p>For more details, see “Adding and Dropping Virtual Processors” on page 15-22.</p> <p>If you are removing virtual processors, the maximum cannot exceed the actual number of processors of the specified type. If you are adding virtual processors, the maximum number depends on the operating system.</p> <p>For more information, see the chapter on using virtual processors in the <i>IBM Informix Administrator’s Guide</i>.</p>
AIO	Performs nonlogging disk I/O to cooked disk spaces	Also performs nonlogging I/O to raw disk spaces if kernel asynchronous I/O (KAIO) is not used.
BTS	Run basic text search index operations and queries.	<p>BTS virtual processors are non-yielding. Specify more BTS virtual processors if you want multiple basic text search queries to be run simultaneously. Use the VPCLASS parameter in the onconfig file to create at least one permanent BTS virtual processor.</p> <p>For more information on basic text search queries, see the <i>IBM Informix Database Extensions User’s Guide</i>.</p>
CPU	Runs all session threads and some system threads	It is recommended that the number of CPU VPs not be greater than the number of physical processors. If KAIO is used, performs I/O to raw disk spaces, including I/O to physical and logical logs. Runs thread for KAIO where available or a single poll thread. The database server uses the number of CPU VPs to allocate resources for parallel database queries (PDQ). If you drop CPU VPs, your queries will run significantly slower. The Reinit field of the onstat -g mgm output displays information on the number of queries that are waiting for running queries to complete after an onmode -p command. Also see the <i>IBM Informix Performance Guide</i> .
ENCRYPT	Executes column-level encryption and decryption routines	Specify more ENCRYPT virtual processors if you have multiple encrypted columns.
JVP	Executes Java user-defined routines in the Java Virtual Machine (JVM)	Specify more JVPs if you are running many Java UDRs.

Element	Purpose	Key Considerations
LIO	Writes to the logical-log files if they are in cooked disk space	Use two LIO virtual processors only if the logical logs are in mirrored dbspaces. The database server allows a maximum of two LIO virtual processors.
PIO	Writes to the physical log if it is in cooked disk space	Use two PIO virtual processors only if the physical log is in a mirrored dbspace. The database server allows a maximum of two PIO virtual processors.
SHM	Performs shared-memory communication	You can use the SHM virtual processor even if the database server is not configured for shared-memory communication.
SOC	Uses sockets to perform network communications	You can use the SOC virtual processor only if the database server is configured for network connections through sockets.
STR	Performs stream pipe connections	
TLI	Uses the Transport Layer Interface (TLI) to perform network communication	You can use the TLI virtual processor only if the database server is configured for network connections through TLI.
<i>vpclass</i>	Names a user-defined virtual processor class	<p>Use the VPCLASS parameter in the <code>onconfig</code> to define the user-defined virtual-processor class. Specify more user-defined virtual processors if you are running many UDRs.</p> <p>On Windows, you can have only one user-defined virtual processor class at a time. Omit the <i>number</i> parameter in the <code>onmode -p vpclass</code> command.</p> <p>For more information on extension classes, see “VPCLASS configuration parameter” on page 1-167.</p>

Related reference:

“onmode and p arguments: Add or remove virtual processors (SQL administration API)” on page 22-83

“VPCLASS configuration parameter” on page 1-167

Adding and Dropping Virtual Processors

The following rules about adding or dropping virtual processors apply:

- You can add but not drop virtual processors of the AIO, PIO, LIO, TLI, SHM, SOC, and STR classes.
- You cannot add or drop virtual processors of the OPT, ADM, ADT, and MSC classes. The database server adds them automatically.
- You can add or drop virtual processors of the CPU, ENCRYPT, JVP, and user-defined (*vpclass*) classes.
-

Windows Only: You can add a virtual processor of any class, but you cannot drop virtual processors.

Dropping Virtual Processors Automatically

Table 15-1 on page 15-23 shows the virtual processors that the database server starts automatically. You cannot add or drop these virtual processors with the `onmode -p` command. To drop these virtual processors, shut down and restart the database server.

Table 15-1. Virtual-Processor Classes That the Database Server Starts Automatically

Virtual-Processor Class	Description
ADM	Performs administrative functions
ADT	Runs auditing processes The database server starts one virtual processor in the audit class when you turn on audit mode by setting the ADTMODE parameter in the ONCONFIG file.
MSC	Services requests for system calls that require a large stack The database server starts this virtual processor automatically.
OPT	Performs I/O to the optical disk The database server starts one OPT virtual processor when you use the Optical Subsystem.

Monitoring poll threads with the onstat utility

While the database server is online, you cannot drop a CPU virtual processor that is running a poll thread. To identify poll threads that run on CPU virtual processors, use the following command:

```
onstat -g ath | grep 'cpu.*poll'
```

The following **onstat -g ath** output shows two CPU virtual processors with poll threads. In this situation, you cannot drop to fewer than two CPU virtual processors.

```
tid tcb      rstcb prty status   vp-class name
8   a362b90 0     2   running 1cpu    tlitcpoll
9   a36e8e0 0     2   cond wait arrived 3cpu
```

The status field contains information, such as running, cond wait, I0 Idle, I0 Idle, sleeping secs: *number_of_seconds*, or sleeping forever. To improve performance, you can remove or reduce the number of threads that are identified as sleeping forever.

For more information on the types of virtual processors, see the chapter on virtual processors and threads in the *IBM Informix Administrator's Guide*.

This command has an equivalent SQL administration API function.

onmode -P: Start, stop, or restart a listen thread dynamically

Use the **onmode -P** command to start, stop, or restart an existing listen thread for a SOCTCP or TLITCP network protocol without interrupting existing connections.

Syntax:

```

▶▶ onmode -P {start | stop | restart} server_name

```

Element	Purpose	Key Considerations
start	Start a new listen thread for a SOCTCP or TLITCP network protocol without interrupting existing connections.	The definition of the listen thread must exist in the sqlhosts file for the server. If the definition of the listen thread does not exist in the sqlhosts file, you must add it before you can start the listen thread dynamically.

Element	Purpose	Key Considerations
stop	Stop an existing listen thread for a SOCTCP or TLITCP network protocol without interrupting existing connections.	The definition of the listen thread must exist in the sqlhosts file for the server.
restart	Stop and start an existing listen thread for a SOCTCP or TLITCP network protocol without interrupting existing connections.	The definition of the listen thread must exist in the sqlhosts file for the server.
server_name	The name of the database server on which you want to start, stop, or restart a listen thread.	

These commands do not update the **sqlhosts** file.

These commands are equivalent to the SQL administration API functions that have **start listen**, **stop listen**, or **restart listen** arguments.

Example

The following command stops and then starts a listen thread for a server named **ids_serv1**:

```
onmode -P restart ids_serv1
```

Related reference:

“start listen argument: Start a listen thread dynamically (SQL administration API)” on page 22-117

“stop listen argument: Stop a listen thread dynamically (SQL administration API)” on page 22-118

“restart listen argument: Stop and start a listen thread dynamically (SQL administration API)” on page 22-101

onmode -R: Regenerate .infos File

The database server uses information from the **.infos.dbservername** file when it accesses utilities. The database server creates and manages this file, and you should never need to do anything to the file. However, if **.infos.dbservername** is accidentally deleted, you must either recreate the file or shut down and restart the database server.

Syntax:

```
▶▶ onmode -R ◀◀
```

Element	Purpose	Key Considerations
-R	Re-creates the .infos.dbservername file	Before you use the -R option, set the INFORMIXSERVER environment variable to match the DBSERVERNAME parameter from the ONCONFIG file. Do not use the -R option if INFORMIXSERVER is one of the DBSERVERALIASES names. For more information, see “ .infos.dbservername ” on page A-7.

onmode -W: Change settings for the SQL statement cache

Syntax:

```

▶▶ onmode -W [STMT_CACHE_HITS hits | STMT_CACHE_NOLIMIT value]

```

Element	Purpose	Key Considerations
STMT_CACHE_HITS <i>hits</i>	Specifies the number of hits (references) to a statement before it is fully inserted in the SQL statement cache. Set <i>hits</i> to 1 or more to exclude ad hoc queries from entering the cache.	You can only increase or reset the value of STMT_CACHE_HITS. The new value displays in the #hits field of the onstat -g ssc output. If <i>hits</i> = 0, the database server inserts all qualified statements and its memory structures in the cache. If <i>hits</i> > 0 and the number of times the SQL statement has been executed is less than STMT_CACHE_HITS, the database server inserts <i>key-only</i> entries in the cache. It inserts qualified statements in the cache after the specified number of hits have been made to the statement. ONCONFIG Parameter: STMT_CACHE_HITS
STMT_CACHE_NOLIMIT <i>value</i>	Controls whether statements are inserted in the SQL statement cache.	If <i>value</i> = 0, the database server inserts no statements in the cache. If <i>value</i> = 1, the database server always inserts statements in the cache. If none of the queries are shared, turn off STMT_CACHE_NOLIMIT to prevent the database server from allocating a large amount of memory for the cache. ONCONFIG Parameter: STMT_CACHE_NOLIMIT

Related reference:

“onmode and W arguments: Reset statement cache attributes (SQL administration API)” on page 22-86

SQL statement cache examples

The following are examples of **onmode -W** commands for changing SQL statement cache (SSC) settings. The changes are in effect for the current database server session only and do not change the ONCONFIG values. When you restart the database server, it uses the default SSC settings, if not specified in the ONCONFIG file, or the ONCONFIG settings. To make the changes permanent, set the appropriate configuration parameter.

```

onmode -W STMT_CACHE_HITS 2 # number of hits before statement is
# inserted into SSC
onmode -W STMT_CACHE_NOLIMIT 1 # always insert statements into
# the cache

```

This command has an equivalent SQL administration API function.

onmode -wf, -wm: Dynamically change certain configuration parameters

Use the **onmode -wf** or **onmode -wm** command to dynamically change specific configuration parameters.

Syntax:

```

▶▶ onmode [ -wf config_param=value | -wm config_param=value ]

```

Element	Purpose	Key considerations
-wf	Updates the value of the specified configuration parameter in the ONCONFIG file.	None.
-wm	Dynamically sets the value of the specified configuration parameter in memory.	The specified <i>value</i> is not preserved when the server is restarted.
<i>config_param=value</i>	Specifies the configuration parameter and its new value.	See Chapter 1, "Database configuration parameters," on page 1-1.

You can use **onmode -wm** or **onmode -wf** to change the following configuration parameters:

- ADMIN_MODE_USERS
- ALARMPROGRAM
- AUTO_AIOVPS
- AUTO_CKPTS
- AUTO_LRU_TUNING
- AUTO_READAHEAD
- AUTO_REPREPARE
- AUTO_STAT_MODE
- BAR_CKPTSEC_TIMEOUT
- BATCHEDREAD_TABLE
- BATCHEDREAD_INDEX
- BLOCKTIMEOUT
- CDR_DELAY_PURGE_DTC
- CDR_LOG_LAG_ACTION
- CDR_LOG_STAGING_MAXSIZE
- CKPTINTVL
- DBSPACETEMP
- DEADLOCK_TIMEOUT
- DEF_TABLE_LOCKMODE
- DELAY_APPLY
- DIRECTIVES
- DRINTERVAL
- DRTIMEOUT

- DS_MAX_QUERIES
- DS_MAX_SCANS
- DS_NONPDQ_QUERY_MEM
- DS_TOTAL_MEMORY
- DUMPCNT
- DUMPSHMEM
- DYNAMIC_LOGS
- ENABLE_SNAPSHOT
- EXPLAIN_STAT
- FILLFACTOR
- HA_ALIAS
- IFX_EXTEND_ROLE
- IFX_FOLDVIEW
- LIMITNUMSESSIONS
- LISTEN_TIMEOUT
- LOG_INDEX_BUILDS
- LOG_STAGING_DIR
- LOGSIZE
- LOW_MEMORY_MGR (**onmode -wf** only, not **onmode -wm**)
- LOW_MEMORY_RESERVE
- LTAPEBLK
- LTAPEDEV
- LTAPESIZE
- LTXEHWM
- LTXHWM
- MAX_INCOMPLETE_CONNECTIONS
- MAX_PDQPRIORITY
- MSG_DATE
- MSGPATH
- NET_IO_TIMEOUT_ALARM
- NS_CACHE
- ONDBSPACEDOWN
- ONLIDX_MAXMEM
- OPTCOMPIND
- RA_PAGES
- REMOTE_SERVER_CFG
- REMOTE_USERS_CFG
- RESIDENT
- RSS_FLOW_CONTROL
- RTO_SERVER_RESTART
- S6_USE_REMOTE_SERVER_CFG
- SBSPACENAME
- SBSPACETEMP
- SDS_TIMEOUT
- SHMADD

- SMX_COMPRESS
- SP_AUTOEXPAND
- SP_THRESHOLD
- SP_WAITTIME
- SQL_LOGICAL_CHAR
- STACKSIZE
- STATCHANGE
- STOP_APPLY
- SYSALARMPROGRAM
- SYSSBSPACENAME
- TAPEBLK
- TAPEDEV
- TAPESIZE
- TBLTBLFIRST
- TBLTBLNEXT
- TEMPTAB_NOLOG
- TXTIMEOUT
- USELASTCOMMITTED
- USTLOW_SAMPLE
- VP_MEMORY_CACHE_KB
- WSTATS

The **onmode -wf** and **onmode -wm** commands have equivalent SQL administration API functions.

Related reference:

“onmode and wf arguments: Permanently update a configuration parameter (SQL administration API)” on page 22-88

“onmode and wm arguments: Temporarily update a configuration parameter (SQL administration API)” on page 22-89

“set onconfig memory argument: Temporarily change a configuration parameter (SQL administration API)” on page 22-108

“set onconfig permanent argument: Permanently change a configuration parameter (SQL administration API)” on page 22-109

“REMOTE_SERVER_CFG configuration parameter” on page 1-117

“REMOTE_USERS_CFG configuration parameter” on page 1-118

“S6_USE_REMOTE_SERVER_CFG configuration parameter” on page 1-125

onmode -wm: Change LRU tuning status

Use the **onmode -wm** option to change the least recently used (LRU) tuning status.

Syntax:

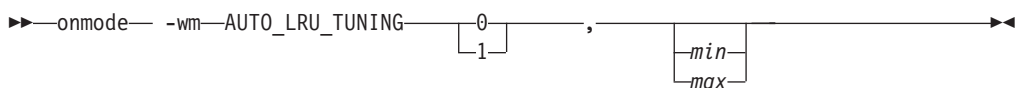

Element	Purpose	Key considerations
-wm	Dynamically sets the value of the specified configuration parameter for the current session.	None.
0	Turns off automatic LRU tuning for the current session.	None.
1	Turns on automatic LRU tuning for the current session.	None.
<i>min</i>	Specifies the percentage of modified pages in the LRU queues at which page cleaning is no longer mandatory.	LRU flushing parameters can be set when LRU tuning is either on or off.
<i>max</i>	Specifies the percentage of modified pages in the LRU queues at which the queue is cleaned.	LRU flushing parameters can be set when LRU tuning is either on or off.

Important: If a *min* value is greater or equal to the *max* value for a specific buffer pool, the *min* value is ignored and no error message is returned.

This command has an equivalent SQL administration API function.

Related reference:

“onmode, wm, and AUTO_LRU_TUNING arguments: Change LRU tuning status (SQL administration API)” on page 22-90

onmode -Y: Dynamically change SET EXPLAIN

Syntax:

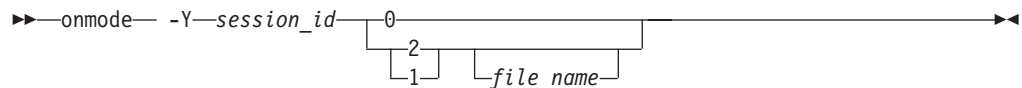

Element	Purpose	Key considerations
<i>file_name</i>	The explain output file name.	If the file's absolute path is not included, the example output file is created in the default example output file location. If the file exists, explain output is appended to it. If a file exists from the SET EXPLAIN statement, that file is not used until dynamic explain is turned off.
<i>session_id</i>	Identifies the specific session.	None.
-Y	Dynamically change the value of the SET EXPLAIN statement.	None.

You can use the SET EXPLAIN statement to display the query plan of the optimizer, an estimate of the number of rows returned, and the relative cost of the query. When you use the **onmode -Y** command to turn on SET EXPLAIN, the output is displayed in the explain output file.

If the session does not exit the section or release the latch, the database server administrator can take the database server offline, as described in “Taking the Database Server to Offline Mode with the -k Option” on page 15-17, to close all sessions.

This command has an equivalent SQL administration API function.

Related reference:

“onmode and z arguments: Terminate a user session (SQL administration API)” on page 22-92

onmode -Z: Kill a distributed transaction

Syntax:

►► onmode -Z address ◀◀

Element	Purpose	Key considerations
-Z address	Kills a distributed transaction associated with the shared-memory address <i>address</i>	<p>This argument must be the address of an ongoing distributed transaction that has exceeded the amount of time that TXTIMEOUT specifies. The address must conform to the operating-system-specific rules for addressing shared-memory. (The address is available from onstat -x output.)</p> <p>This option is not valid until the amount of time that the ONCONFIG parameter TXTIMEOUT specifies has been exceeded. The -Z option should rarely be used and only by an administrator of a database server involved in distributed transactions.</p> <p>For information on initiating independent actions in a two-phase commit protocol, see the chapter on multiphase commit protocols in the <i>IBM Informix Administrator's Guide</i>.</p>

Distributed transactions provide the ability to query data on different database servers.

Attention: If applications are performing distributed transactions, killing one of the distributed transactions can leave your client/server database system in an inconsistent state. Try to avoid this situation.

This command has an equivalent SQL administration API function.

Related reference:

“onmode and Z arguments: Terminate a distributed transaction (SQL administration API)” on page 22-93

Chapter 16. The ON-Monitor Utility

Using ON-Monitor (UNIX)

Use the ON-Monitor utility to perform various administrative tasks. This section provides a quick reference for the ON-Monitor screens. To start ON-Monitor, execute the following command from the operating-system prompt:

```
onmonitor
```

If you are logged in as user **informix** or user **root**, the main menu appears. All users other than **informix** and **root** have access only to the Status menu.

The ON-Monitor main menu displays the following menus:

- **Status** menu
- **Parameters** menu
- **Dbspaces** menu
- **Mode** menu
- **Force-Ckpt** menu
- **Archive** menu
- **Logical-Logs** menu
- **Exit** option

These menus are shown on the following pages (Table 16-1 on page 16-2 through Table 16-7 on page 16-3).

To obtain ON-Monitor version information, execute the **-V** or **-version** command from the operating-system prompt. For complete information on version information, see “Obtaining Utility Version Information” on page 6-1

You cannot use ON-Monitor on High-Availability Data Replication (HDR) secondary servers, remote standalone (RS) secondary servers, or shared disk (SD) secondary servers.

Navigating ON-Monitor and Using Help

All menus and screens in ON-Monitor function in the same way. For menus, use the arrow keys or SPACEBAR to scroll to the option that you want to execute and press RETURN, or press the first capitalized letter of the option (usually the first letter). When you move from one option to the next by pressing SPACEBAR or an arrow key, the option explanation (line 2 of the menu) changes.

If you want general instructions for a specific screen, press CTRL-W. If you need help to determine what you should enter in a field on the screen, use the TAB key to highlight the field and press CTRL-F or F2.

Some of the menus display ellipses (...) on the far right or left side. The ellipses indicate that you can move in the direction of the dots, using the arrow keys or SPACEBAR, to view other options.

Executing Shell Commands Within ON-Monitor

To execute a shell command from within ON-Monitor, type an exclamation point (!) followed by the command. For example, to list the files in the current directory, type the following command:

```
!ls
```

ON-Monitor Screen Options

Table 16-1. Status Menu

Menu	Description
Profile	Displays database server performance statistics
Userthreads	Displays the status of active user threads
Spaces	Displays status information about database server storage spaces and chunks
Databases	Displays the name, owner, and logging mode of the 100 first databases
Logs	Displays status information about the physical-log buffer, the physical log, the logical-log buffer, and the logical-log files
Archive	Displays a list of all backup tapes and logical-log files that you require to restore data using ontape
data-Replication	Displays High-Availability Data-Replication (HDR) status and configuration
Output	Stores the output of other status information in a specified file
Configuration	Copies the current database server configuration to a file

Table 16-2. Parameters Menu

Menu	Description
Initialize	Initializes database server disk space or modifies disk-space parameters
Shared-Memory	Initializes database server shared memory or modifies shared-memory parameters
perFormance	Specifies the number of virtual processors for each VP
data-Replication	Specifies the HDR parameters
diaGnostics	Specifies values for the diagnostics parameters
pdQ	Changes parameters for parallel database queries
Add-Log	Adds a logical-log file to a dbspace
Drop-Log	Drops a logical-log file from a dbspace
Physical-Log	Changes the size or the location of the database server physical log

Table 16-3. Dbspaces Menu

Menu	Description
Create	Creates a dbspace
BLOBSpace	Creates a blobspace
Mirror	Adds mirroring to an existing storage space or ends mirroring for a storage space
Drop	Drops a storage space from the database server configuration

Table 16-3. Dbspaces Menu (continued)

Menu	Description
Info	Displays the identification number, location, and fullness of each chunk assigned to a storage space
Add_chunk	Adds a chunk to a storage space
datasKip	Changes the database parameter
Status	Changes the status of a chunk in a mirrored pair

Table 16-4. Mode Menu

Menu	Description
Startup	Initializes shared memory and takes the database server to quiescent mode
On-Line	Takes the database server from quiescent to online mode
Graceful-Shutdown	Takes the database server from online to quiescent mode so users can complete work
Immediate-Shutdown	Takes the database server from online to quiescent mode in 10 seconds
Take-Offline	Detaches shared memory and immediately takes the database server to offline mode
Add-Proc	Adds virtual processors
Drop-Proc	Drops virtual processors
Decision-support	Sets decision-support parameters dynamically
Administration	Tells the server to change into administration mode

Table 16-5. Force-Ckpt Menu

Menu	Description
Force-Ckpt	Displays the time of the most-recent checkpoint or forces the database server to execute a checkpoint

Table 16-6. Archive Menu

Menu	Description
Tape-Parameters	Modifies the ontape parameters for the backup tape device

Table 16-7. Logical Logs Menu

Menu	Description
Databases	Modifies the logging status of a database
Tape-Parameters	Modifies the ontape parameters for the logical-log backup tape device

Chapter 17. The onparams Utility

Use the **onparams** utility to add or drop a logical-log file, change physical-log parameters, and add a new buffer pool.

In This Chapter

This chapter shows you how to use the following **onparams** options:

- “**onparams -a -d *dbspace***: Add a logical-log file” on page 17-2
- “**onparams -d -l *lognum***: Drop a logical-log file” on page 17-2
- “**onparams -p**: Change physical-log parameters” on page 17-3
- “**onparams -b**: Add a new buffer pool” on page 17-4

Any **onparams** command fails if a storage-space backup is in progress. If you do not use any options, **onparams** returns a usage statement.

You cannot use the **onparams** utility on High-Availability Data Replication (HDR) secondary servers, remote standalone (RS) secondary servers, or shared disk (SD) secondary servers.

You can also use SQL administration API commands that are equivalent to **onparams** commands to add or drop a logical-log file, change physical-log parameters, and add a new buffer pool.

On UNIX, you must be logged in as user **root** or user **informix** to execute **onparams**. Only user **informix** is allowed to execute the SQL administration API *command* strings.

On Windows, you must be a member of the **Informix-Admin** group to execute **onparams**.

onparams Syntax

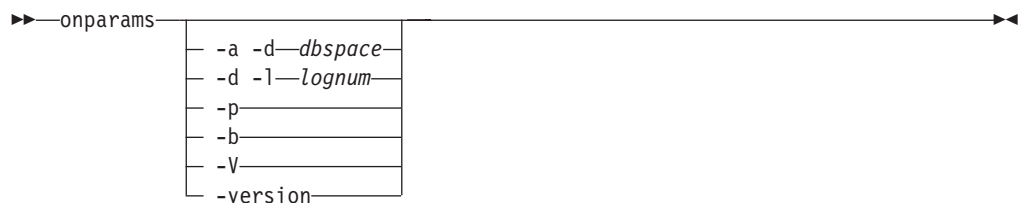

Element	Purpose	Key Considerations
-V	Displays the software version number and the serial number	See “Obtaining Utility Version Information” on page 6-1.
-version	Displays the build version, host, OS, number and date, as well as the GLS version	See “Obtaining Utility Version Information” on page 6-1.

onparams -a -d *dbspace*: Add a logical-log file

Syntax:

```
▶▶ onparams -a -d dbspace [ -s size ] [ -i ] ▶▶
```

Element	Purpose	Key considerations
-a -d <i>dbspace</i>	Adds a logical-log file to the end of the log-file list to the specified <i>dbspace</i>	<p>You can add a log file to a <i>dbspace</i> only if the database server has adequate contiguous space. The newly added log files have a status of A and are immediately available for use. You can add a log file during a backup. You can have a maximum of 32,767 logical-log files. Use onstat -l to view the status of your logical-log files. It is recommended that you take a level-0 backup of the root <i>dbspace</i> and the <i>dbspace</i> that contains the log file as soon as possible.</p> <p>You cannot add a log file to a <i>blobospace</i> or <i>sbspace</i>.</p> <p>Syntax must conform to the Identifier segment; see <i>IBM Informix Guide to SQL: Syntax</i>.</p>
-i	Inserts the logical-log file after the current log file	Use this option when the Log File Required alarm prompts you to add a logical-log file.
-s <i>size</i>	Specifies a size in kilobytes for the new logical-log file	<p>This value must be an unsigned integer greater than or equal to 200 kilobytes</p> <p>If you do not specify a size with the -s option, the size of the log file is taken from the value of the LOGSIZE parameter in the ONCONFIG file when database server disk space was initialized.</p> <p>For information on changing LOGSIZE, see the chapter on managing logical-log files in the <i>IBM Informix Administrator's Guide</i>.</p>

This command has an equivalent SQL administration API function.

Related reference:

“add log argument: Add a new logical log (SQL administration API)” on page 22-16

onparams -d -l *lognum*: Drop a logical-log file

Syntax:

```
▶▶ onparams -d -l lognum [ -y ] ▶▶
```

Element	Purpose	Key considerations
-d -l <i>lognum</i>	Allows you to drop a logical-log file specified by the log file number	<p>Restrictions: The <i>lognum</i> value must be an unsigned integer greater than or equal to 0.</p> <p>You can obtain the <i>lognum</i> from the number field of onstat -l. The sequence of <i>lognum</i> might be out of order.</p>
-y	Causes the database server to automatically respond yes to all prompts	None.

Usage

You can only drop one log files at a time.

The database server requires a minimum of three logical-log files at all times. You cannot drop a log if your logical log is composed of only three log files.

Important: Before you can drop any of the first three logical-log files, you must add new logical-log files and run a backup of the logical-log files. The backup must be run using either the **ontape -a** command or the **ontape -c** command. After you add the new logical-log files and run a backup, you can then use **onparams -d -llognum** to delete the first three logical-log files.

The status of the log file determines if the log file can be dropped, and the actions taken by the database server when the log file is dropped:

- If you drop a log file that has never been written to, status is newly Added (**A**), the database server deletes the log file and frees the space immediately.
- If you drop a used log file that has a status of User (**U**) or Free (**F**), the database server marks the log file as Deleted (**D**). After you take a level-0 backup of the dbspaces that contain the log files and the root dbspace, the database server deletes the log file and frees the space.
- You cannot drop a log file that is currently in use (**C**) or contains the last checkpoint record (**L**).

This command has an equivalent SQL administration API function.

When you move logical-log files to another dbspace, use the **onparams** commands to add and drop logical-log files. See moving a logical-log file, in the section on managing logical-log files in the *IBM Informix Administrator's Guide*.

Related reference:

“drop log argument: Drop a logical log (SQL administration API)” on page 22-48

onparams -p: Change physical-log parameters

Syntax:

```
▶▶ onparams -p -s size [-d dbspace] [-y]
```

Element	Purpose	Key Considerations
-p	Changes the physical log	Whenever you use the onparams -p command, you must include the -s parameter. Additionally, you can specify the -d and -y parameters. The database server must be in either administration, online, or quiescent mode to specify the -p parameter. The database server does not need to be restarted for the changes take effect.
-s size	Changes the size (in kilobytes) of the physical log	This value must be an unsigned integer greater than or equal to 200 kilobytes. Attention: If you move the log to a dbspace without adequate contiguous space or increase the log size beyond the available contiguous space, the operation will fail and the physical log will not change.

Element	Purpose	Key Considerations
-d <i>dbspace</i>	Changes the location of the physical log to the specified <i>dbspace</i>	The space allocated for the physical log must be contiguous. Syntax must conform to the Identifier segment; see the <i>IBM Informix Guide to SQL: Syntax</i> .
-y	Causes the database server to automatically respond yes to all prompts	None.

Related reference:

“alter plog argument: Change the physical log (SQL administration API)” on page 22-21

“LOGSIZE configuration parameter” on page 1-90

Backing Up After You Change the Physical-Log Size or Location

The database server must be in either the online or quiescent mode when you change the physical log. The database server does not need to be restarted for the changes to take effect.

Create a level-0 backup of the root *dbspace* immediately after you change the physical-log size or location. This backup is critical for proper recovery of the database server.

Changing the Size of the Physical Log and Using Non-Default Page Sizes

If you use non-default page sizes, you might need to increase the size of your physical log. If you perform many updates to non-default pages you might need a 150 to 200 percent increase of the physical log size. Some experimentation might be needed to tune the physical log. You can adjust the size of the physical log as necessary according to how frequently the filling of the physical log triggers checkpoints.

onparams -b: Add a new buffer pool

Use the **onparams -b** command to create a buffer pool that corresponds to the page size of the *dbspace*.

Syntax:

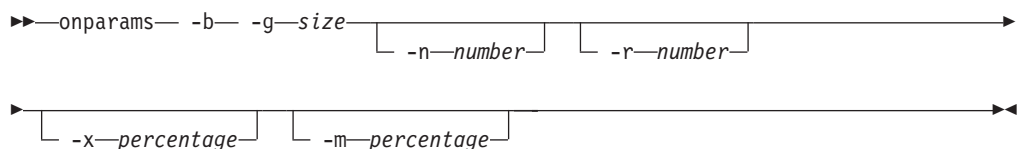

Element	Purpose	Key considerations
-b	Creates a new buffer pool	You can add a new buffer pool while the database server is running.

Element	Purpose	Key considerations
-g <i>size</i>	Specifies the size in kilobytes of the buffer pages to create	Each dbspace you create with a non-default page size must have a corresponding buffer pool with the corresponding page size. If you create a dbspace with a page size that has no buffer pool, the system will automatically create a buffer pool using the fields in the default line of the BUFFERPOOL parameter. The size of the buffer pages must be between 2 and 16 kilobytes and it must be a multiple of the default page size.
-m <i>percent</i>	Specifies the percentage of modified pages in the LRU queues at which page cleaning is no longer mandatory	Fractional values are allowed. If you do not specify this option, the percentage used is the value of the <i>lru_min_dirty</i> field as set in the default line of the BUFFERPOOL configuration parameter.
-n <i>number</i>	Specifies the number of buffers in the buffer pool	The range is 500 - 2147483647. If you do not specify this option, the number used is the value of <i>buffers</i> as set in the default line of the BUFFERPOOL configuration parameter.
-r <i>number</i>	Specifies the number of LRU (least-recently-used) queues in the shared-memory buffer pool	Range of values: <ul style="list-style-type: none"> • 32-bit platforms: 1 - 128 • 64-bit platforms: 1 - 512 If you do not include this option, the number of LRU queues allocated is equal to the value of <i>lrus</i> as set in the default line of the BUFFERPOOL configuration parameter.
-x <i>percent</i>	Specifies the default percentage of modified pages in the LRU queues at which the queue is cleaned	Fractional values are allowed. If you do not specify this option, the percentage used is the value of <i>lru_max_dirty</i> as set in the default line of the BUFFERPOOL configuration parameter.

The values of the elements correspond to the values of the fields of the BUFFERPOOL configuration parameter.

You should create a buffer pool for a dbspace before you create the dbspace. You cannot reduce or increase the number of buffers in an existing buffer pool while the database server is running. You also cannot drop a buffer pool while the database server is running. You can, however, add new buffer pools with a new size while the database server is running.

Buffer pools added with the **onparams** utility are put into virtual memory, not into resident memory. Upon restart, buffer pool entries will go into resident memory depending on the amount of memory that is available.

When you add a new buffer pool with the **onparams** utility or when you add a dbspace with a different page size (with the **onspaces** utility), a new entry for the BUFFERPOOL configuration parameter is added in the onconfig file.

This command has an equivalent SQL administration API function.

Related reference:

“add bufferpool argument: Add a buffer pool (SQL administration API)” on page 22-13

“BUFFERPOOL configuration parameter” on page 1-36

Examples of onparams Commands

The following are examples of **onparams** commands:

```
onparams -a -d rootdbs -s 1000 # adds a 1000-KB log file to rootdbs
onparams -a -d rootdbs -i      # inserts the log file after the current log
onparams -d -l 7               # drops log 7
onparams -p -d dbpace1 -s 3000 # resizes and moves physical-log to dbpace1
onparams -b -g 6 -n 3000 -r 2 -x 2.0 -m 1.0 # adds 3000 buffers of size
6K bytes each with 2 LRUS with maximum dirty of 2% and minimum dirty of 1%
```

Chapter 18. The onpassword utility

Use the **onpassword** utility to encrypt and decrypt a password file so that the Connection Manager and Enterprise Replication utilities can connect to servers that require a secure connection.

Syntax

```
▶▶ onpassword -k access_key [-e text_file] [-d output_filename] ▶▶
```

Element	Purpose	Key Considerations
-k <i>access_key</i>	Specifies the key used to encrypt a plain text password file. The same key must be specified to decrypt the file.	The length of the <i>access_key</i> cannot exceed 24 bytes. To modify the password file, you must decrypt the file using the <i>access_key</i> that was used to encrypt the file. If the access key is lost or forgotten, decrypting the password file is not possible. In such cases, the recommended solution is to re-encrypt the plain text password file. If the plain text password file has been deleted then a new file must be created. Also see "Password key" on page 18-2.
-e <i>text_file</i>	Encrypts the specified ASCII text file that contains user IDs, passwords, and server names.	The output file is always written to \$INFORMIXDIR/etc/passwd_file. See "Password file structure" on page 18-2.
-d <i>output_filename</i>	Decrypts the specified encrypted password file.	The file is written to the specified location. See "Password file structure" on page 18-2.

Usage

The **onpassword** utility is used to encrypt or decrypt password files. A password file contains user IDs, passwords, and server information that are required for connecting to Informix servers in high-availability clusters or Enterprise Replication domains. The password file is used by the Connection Manager and the **cdr** utility. Only users logged in as **informix** have permission to run the **onpassword** utility.

You decrypt and modify the password file if you add or remove servers from your cluster or Enterprise Replication domain, change the passwords, or change your encryption key.

On both UNIX and Windows systems, an encrypted password file is required in order to configure the Connection Manager and Enterprise Replication to run in an untrusted network environment. In certain situations, an encrypted password file is also required for trusted network environments. An encrypted password file is required when a local system account attempts to connect to a server within a high-availability cluster or Enterprise Replication domain, or when the user ID does not exist on one or more servers. The password file is required because a local system account or a Windows-only account cannot directly connect to a remote server. In this case, the encrypted password file provides the correct system-level access for the request.

An encrypted password file must be located on each server on which Enterprise Replication utility commands are run. Also, an encrypted password file must be located on each server on which the Connection Manager is running.

The user IDs of the password file must have the following privileges (only user **informix** has these privileges by default):

- Permission to connect to the **sysadmin** database.
- CONNECT permission on the remote servers.
- Inclusion in the DBSA group (group **informix** on UNIX platforms, **Informix-Admin** group on Windows)

The encrypted password file cannot be copied from one platform to another. For example, password files created on a UNIX platform will not work on a Windows platform.

Password file structure

The password file consists of a separate line for each Enterprise Replication group name, each network port service, and each high-availability cluster group name. Each line also must contain the name of an alternate server, and the user ID and password for the server.

If a group is configured for both a high-availability cluster and for Enterprise Replication, there should be a line in the password file for each server in the cluster and for the group specifying the alternate server.

The input file (*text_file*) is an ASCII text file with the following structure:
Server_or_group AlternateServer UserName Password

The file contains the server names, user names, and passwords that must be specified in order to connect to the appropriate server. *AlternateServer* specifies the name of an alternate server to connect with in case the connection cannot be made to *ServerName*. For example, *AlternateServer* name is used when *ServerName* is a located on a secure port (using the s=6 option in the sqlhosts file).

Password key

The password key can be any sequence of numbers or letters up to 24 bytes. To include a space in the key, enclose the entire key in quotation marks. You must specify a key to encrypt the file and specify the same key to decrypt the file.

Examples

To encrypt a file named `passwords.txt` by using a key named `EncryptKey` and place the encrypted file in `$INFORMIXDIR/etc/passwd_file`:

```
onpassword -k EncryptKey -e ./passwords.txt
```

To decrypt the `$INFORMIXDIR/etc/passwd_file` and place the unencrypted file in `./passwords.txt`:

```
onpassword -k EncryptKey -d ./passwords.txt
```

Configuring secure connections using a password file

You can use secure connections in a high-availability cluster, an Enterprise Replication domain, and in a combined configuration with both high-availability clusters and an Enterprise Replication domain.

High-availability cluster example

Figure 18-1 illustrates a high-availability cluster configuration. Using a secure connection in a high-availability cluster is appropriate when the servers connect over a public network. In the figure, **computer1** represents the cluster primary server and **computer2** is a secondary server.

The Connection Manager retrieves user IDs and passwords from the password file and uses them to access the primary and secondary servers in the cluster. For high-availability cluster environments, the password file must contain an entry for each group name and each alternate server name for every secondary server.

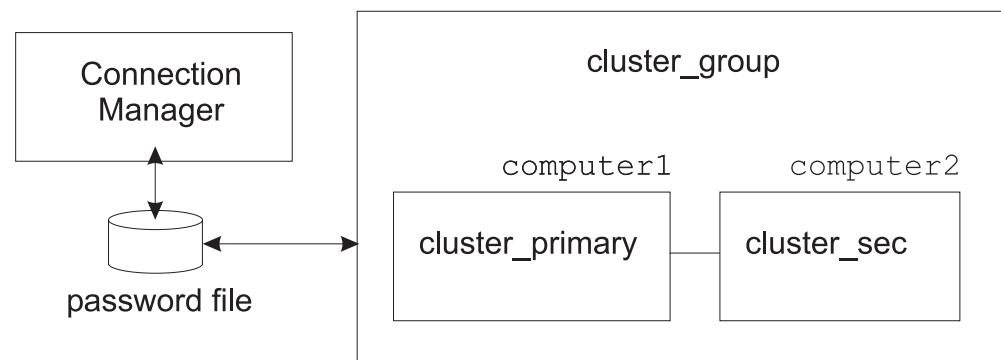

Figure 18-1. High-availability cluster password file configuration

The sqlhosts file for the high-availability cluster is configured as follows:

```
cluster_primary  ontlitcp  computer1  rach21  s=6
cluster_sec      ontlitcp  computer2  rach22  s=6

cluster_group    group      -          -
cluster_primary_a ontlitcp  computer1  rach23  g=cluster_group
cluster_sec_a    ontlitcp  computer2  rach24  g=cluster_group
```

The password file for the high-availability cluster is configured as follows:

```
cluster_group  cluster_primary_a  informix  pass4DBSA
cluster_group  cluster_sec_a      informix  pass4DBSA
cluster_primary cluster_primary_a  informix  pass4DBSA
cluster_sec    cluster_sec_a      informix  pass4DBSA
```

Enterprise Replication example

Figure 18-2 on page 18-4 illustrates a configuration with secure connections in an Enterprise Replication environment. The Enterprise Replication domain is named **er_group_1** and consists of computers named **computer1** and **computer2**.

Using a secure connection in an Enterprise Replication environment is appropriate when the servers connect over a public network.

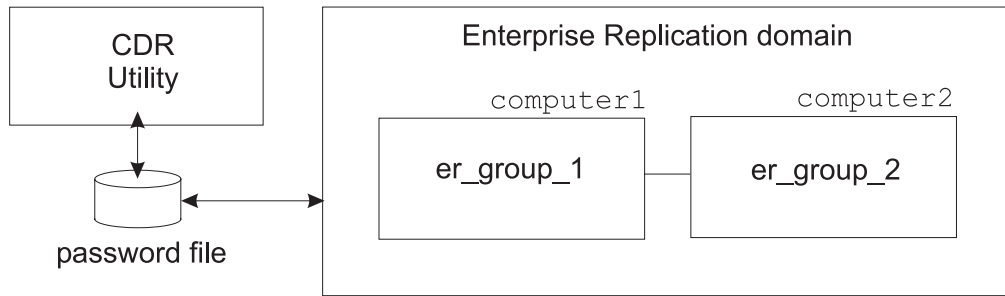

Figure 18-2. Enterprise Replication password file example

The `sqlhosts` file contains two entries for each computer; one entry is defined as a secure (`s=6`) connection and the other entry is defined without the `s=6` option. The non-secure connection is used by the CDR utility, which cannot connect to a secure server. The non-secure servers are listed as alternate servers in the password file.

The password file must contain a record for each Enterprise Replication group name and alternate server name. A user ID and password must also be provided. The password file must also contain a record for each network port service server and alternate server name, and user ID and password.

The `sqlhosts` file for the Enterprise Replication environment is configured as follows:

```
er_group1 group - - i=100
er_srv_1 ontlitcp computer1 rach1 g=er_group1,s=6
er_srv_1a ontlitcp computer1 rach2

er_group2 group - - i=200
er_srv_2 ontlitcp computer2 rach3 g=er_group2,s=6
er_srv_2a ontlitcp computer2 rach4
```

The password file for the Enterprise Replication environment is configured as follows:

```
er_group1 er_srv_1a informix pass4DBSA
er_srv_1 er_srv_1a informix pass4DBSA
er_srv_1a er_srv_1a informix pass4DBSA

er_group2 er_srv_2a informix pass4DBSA
er_srv_2 er_srv_2a informix pass4DBSA
er_srv_2a er_srv_2a informix pass4DBSA
```

High-availability cluster with Enterprise Replication example

You configure the `sqlhosts` file and a password file for secure connections in an environment that contains both a high-availability cluster and Enterprise Replication. In the `sqlhosts` file, **computer3** is the **er_group_2** server.

The `sqlhosts` file for the combined high-availability cluster and Enterprise Replication environment is configured as follows:

```
# Configuration for ER ports for cluster
er_group_1 group - - i=100
cluster_primary_a ontlitcp computer1 rach1 g=er_group_1,s=6
cluster_sec_a ontlitcp computer2 rach2 g=er_group_1,s=6

# Configuration for non-ER ports for cluster
cluster_group group - -
cluster_primary ontlitcp computer1 rach3 g=cluster_group
```

```

cluster_sec      ontlitcp  computer2  rach4 g=cluster_group

# Configuration for ER ports on computer3
er_group_2      group      -          -      i=200
er_srv_2_a      ontlitcp  computer3  rach5 g=er_group_2,s=6

# Configuration for non-ER port on computer3
er_srv_2        ontlitcp  computer3  rach6

```

The password file for the combined high-availability cluster and Enterprise Replication environment is configured as follows:

```

er_group_1      cluster_primary  informix  Pass4DBSA
er_group_1      cluster_sec      informix  Pass4DBSA
cluster_primary_a cluster_primary  informix  Pass4DBSA
cluster_primary cluster_primary  informix  Pass4DBSA
cluster_sec_a   cluster_sec      informix  Pass4DBSA
cluster_group   cluster_primary  informix  pass4DBSA
cluster_group   cluster_sec      informix  pass4DBSA
er_group_2      er_srv_2         informix  Pass4DBSA
er_srv_2_a      er_srv_2         informix  Pass4DBSA
er_srv_2        er_srv_2         informix  Pass4DBSA

```



Chapter 19. The ifxclone utility

You use the **ifxclone** utility to create a snapshot of a database server.

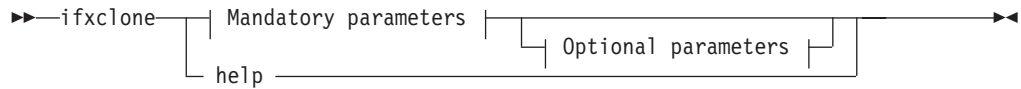
Syntax

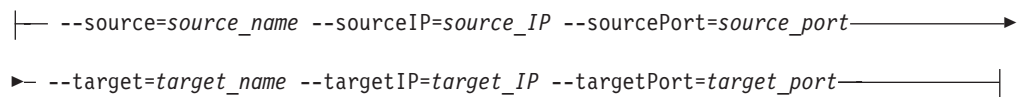

Mandatory parameters:



Optional parameters:

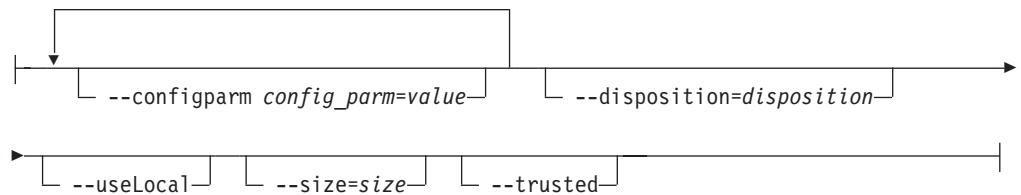

Element	Purpose	Key Considerations
<i>config_parm=value</i>	Specifies an optional configuration parameter and value to set on the target server.	Certain configuration parameters on the source server must match those on the target server. See "Prerequisites for cloning an RS secondary server" on page 19-5.
<i>disposition</i>	Specifies the final disposition of the new server instance. Valid values are: RSS and ER.	If the --disposition (-d) parameter is not specified, a standard server is created.
<i>size</i>	Specifies the size of the target server. Valid values are tiny, small, medium, and large.	If the size parameter is not specified, the size parameters from the source instance are used.
<i>source_name</i>	Specifies the name of the source instance.	The source server must be a primary server and cannot be a secondary server.
<i>source_IP</i>	Specifies the source server instance TCP/IP address.	
<i>source_port</i>	Specifies the TCP/IP port address of the source server instance, or the name of a service associated with the port.	
<i>target_name</i>	Specifies the name of the target server instance.	

Element	Purpose	Key Considerations
<i>target_IP</i>	Specifies the target server instance TCP/IP address.	
<i>target_port</i>	Specifies the TCP/IP port address of the target server instance, or the name of a service associated with the port.	

The following table describes the options of the **ifxclone** utility.

Long Form	Short Form	Meaning
--configParm	-c	Specifies the name and value of a configuration parameter to set on the target server.
--disposition	-d	Specifies the disposition of the new server instance.
--help	-h	Displays usage information.
--size	-s	Specifies the size of the target instance.
--source	-S	Specifies the name of the source server instance.
--sourceIP	-I	Specifies the TCP/IP address of the source server instance.
--sourcePort	-P	Specifies the TCP/IP port address of the source server instance, or the name of a service associated with the port.
--target	-t	Specifies the name of the target server instance.
--targetIP	-i	Specifies the TCP/IP address of the target server instance.
--targetPort	-p	Specifies the TCP/IP port address of the target server instance, or the name of a service associated with the port.
--trusted	-T	Specifies that the server is trusted and that it is not necessary to obtain a userid and password to access the server.
--useLocal	-L	Specifies that the configuration information contained in the source server <code>onconfig</code> file should be merged with the target server <code>onconfig</code> file. Certain configuration parameters on the source server must match those on the target server. See "Prerequisites for all servers" on page 19-4.

Usage

Use the **ifxclone** utility to clone a server with minimum setup or configuration, or to quickly add a new node to an existing ER replication domain. When the **ifxclone** utility is run, the majority of the setup information is obtained from the server node that is being cloned. Successfully cloning a server might still require some post-configuration steps to achieve a better running system.

The source server is the server that contains the data you wish to clone. The target server is the server that is to be loaded with data from the source server. You must run the **ifxclone** utility from the target server.

To run the **ifxclone** utility on a UNIX computer, you must run the command on the target server as user root, user informix, or as a member of the informix group. You must also be a DBSA on the source server.

To run the **ifxclone** utility on a Windows computer, you must run the command on the target server as a member of the local administrators group. You must also be a DBSA on the source server and you must belong to the Informix-Admin group on the source server.

The **ifxclone** utility uses the onconfig and sqlhosts configuration files from the source server to configure the target server. The **ifxclone** utility also configures some additional configuration settings, but only those required to configure the clone server. The **ifxclone** utility is not meant to configure all of the possible configuration options, but rather to provide enough configuration to clone the source server.

The number of CPU VPs and buffers on the target server can be configured using the size parameter. Table 19-1 lists the number of CPU VPs and buffer pools created on the target server for each size option. Additional refinement of the generated configuration should be performed after the target system is created. If the size configuration is omitted, the parameter configured on the source server is used.

Table 19-1. List of size parameter values

Size	Number of CPU VPs	Number of buffers
tiny	1	50,000
small	2	100,000
medium	4	250,000
large	8	500,000

You can use the **-c** option to specify a configuration parameter and its value on the target server. You can also use an existing configuration file. If the target server contains a configuration file that is different than the source server configuration file, the **ifxclone** utility does not overwrite the file but modifies those parameters that must match the source server during the clone process.

The useLocal (**-L**) parameter is required if the target server is located on the same host machine as the source server.

If the useLocal parameter is specified, the **ifxclone** utility merges the source server onconfig file with the target server onconfig file. The configuration parameters listed in "Prerequisites for all servers" on page 19-4 are overwritten by the **ifxclone** utility and the rest of the parameters are not affected.

If the useLocal parameter is not specified as an input parameter, the **ifxclone** utility uses the source server's onconfig file as the target's onconfig file and uses the server name from the input parameters of the **ifxclone** utility.

If the `useLocal` parameter is not specified, the `ifxclone` utility updates the `sqlhosts` file on the host server with the target server entry and copies both entries to the target's `sqlhosts` file.

The order of precedence of options for the `ifxclone` parameters is as follows:

- The `--configParm` (-c) parameter takes precedence over the configuration file on the source server.
- The `--size` (-s) parameter takes precedence over merged configuration parameters or the settings in the local configuration file.
- The `--configParm` (-c) parameter takes precedence over the `--size` (-s) parameter.
- Parameters that must be the same on each server take precedence over all other options.

Prerequisites for all servers

Perform the following prerequisites before cloning a server:

- Hardware and software requirements for the servers are generally the same as those for HDR secondary servers (refer to the machine notes for specific supported platforms).
- Both the source and target servers must be part of a trusted network environment. See Network security files for information about configuring a trusted environment.
- If the disposition of the target server is specified as ER or RSS then you must provide users with connection permission to the `sysadmin` database on the source server. By default, connection permission to the `sysadmin` database is limited to user `informix`.
- Only one server clone process can occur at a time. Do not start cloning a second server until the first clone process has completed running.
- The source server must have the `ENABLE_SNAPSHOT_COPY` configuration parameter set to 1 in the `onconfig` file.

Archive operations, such as `ontape` and `ON-Bar` commands, are not allowed while cloning a server. Perform your data archive activities before starting to clone a server.

The following environment variables must be set on the target server before cloning a server:

- `INFORMIXDIR`
- `INFORMIXSERVER`
- `INFORMIXSQLHOSTS`
- `ONCONFIG`

The following configuration parameter values must be identical on both the source and target servers:

- `DRAUTO`
- `DRINTERVAL`
- `DRTIMEOUT`
- `LOGBUFF`
- `LOGFILES`
- `LOGSIZE`
- `LTAPEBLK`

- LTAPESIZE
- ROOTNAME
- ROOTSIZE
- PHYSBUFF
- PHYSFILE
- STACKSIZE
- TAPEBLK
- TAPESIZE

If the MIRROR configuration parameter is enabled on the target server, the following configuration parameters also must match between the source and target servers:

- MIRRORPATH
- MIRROROFFSET

The database server allows only certain combinations of the MIRROR configuration parameter on the source and target servers. See Table 19-2.

Table 19-2. Allowable settings of the MIRROR configuration parameter on source and target servers

MIRROR configuration parameter set on the source server	MIRROR configuration parameter set on the target server	Permitted or not permitted
No	No	Permitted
Yes	Yes	Permitted
Yes	No	Permitted
No	Yes	Not permitted. If this setting is configured, the server issues a warning and disables the MIRROR parameter in the target server onconfig file.

Prerequisites for cloning an RS secondary server

1. Set the following environment variables on the target server:
 - INFORMIXDIR
 - INFORMIXSERVER
 - ONCONFIG
 - INFORMIXSQLHOSTS
2. On the target server, create all of the chunks and mirror chunks that exist on the source server. If the target server is using mirroring, the mirror chunk paths must match those of the source server and the chunks must exist. Follow these steps to create the chunks and (if necessary) mirror chunks for the target server:
 - a. On the source server, run the **onstat -d** command to display a list of chunks and mirror chunks:

```
onstat -d
```
 - b. On the target server, log in as user informix and use the **touch**, **chown**, and **chmod** commands to create the set of chunks and mirror chunks reported by the **onstat -d** command. For example, to create a chunk named `/usr/informix/chunks/rootdbs.chunk`, follow these steps:

```

$ su informix
Password:
$ touch /usr/informix/chunks/rootdbs.chunk
$ chown informix:informix /usr/informix/chunks/rootdbs.chunk
$ chmod 660 /usr/informix/chunks/rootdbs.chunk

```

- c. Repeat all of the commands in the previous step for each chunk reported by the **onstat -d** command.
3. Run the **ifxclone** utility with the appropriate parameters on the target system.
4. Optionally, create **onconfig** and **sqlhosts** files on the target server.

Example 1, Cloning an RS secondary server using the source server configuration

This example shows how to clone a server by using the **onconfig** and **sqlhosts** configuration files from the source server.

In this example, omitting the **-L** option causes the **ifxclone** utility to retrieve the necessary configuration information from the source server. The configuration files are used as a template to create the target server configuration. Having the **ifxclone** utility create the configuration files for you saves time and reduces the chance of introducing errors into the configuration files.

For this example, assume that the source server (Amsterdam) has an **sqlhosts** file configured as follows:

```

#Server Protocol HostName Service Group
Amsterdam onsoctcp 192.168.0.1 123 -

```

You also need the name, IP address, and port number of the target server. The following values are used for this example:

- Source server name: Amsterdam
 - Source IP address: 192.168.0.1
 - Source port: 123
 - Target server name: Berlin
 - Target IP address: 192.168.0.2
 - Target port: 456
1. On the target server, log in as user **informix** and use the **touch**, **chown**, and **chmod** commands to create, change the owner, and set the permissions for the chunks. The chunk paths must match the paths of the chunks on the source server.

2. On the target server, run the **ifxclone** utility:

```

ifxclone -T -S Amsterdam -I 192.168.0.1 -P 123 -t Berlin
-i 192.168.0.2 -p 456 -d RSS

```

The **ifxclone** utility modifies the **sqlhosts** file on the source server and creates a copy of the file on the new target server. The **sqlhosts** file on the target server is the same as the source server:

```

#Server Protocol HostName Service Group
Amsterdam onsoctcp 192.168.0.1 123 -
Berlin onsoctcp 192.168.0.2 456

```

Example 2, Cloning an RS secondary server by merging the source server configuration

Use the **-L** (**--useLocal**) option to create a clone of a server on a remote host computer: The **-L** option is used to merge the source **onconfig** file configuration

information with the target onconfig file. This option also copies the source sqlhosts file to the target server. The following values are used for this example:

- Source server name: Amsterdam
 - Source IP address: 192.168.0.1
 - Source port: 123
 - Target server name: Berlin
 - Target IP address: 192.168.0.2
 - Target port: 456
1. Create the onconfig and sqlhosts files and set the environment variables on the target computer.
 2. On the target server, log in as user informix and use the **touch**, **chown**, and **chmod** commands to create, change the owner, and set the permissions for the chunks. The chunk paths must match the paths of the chunks on the source server.
 3. On the target server, run the **ifxclone** utility:

```
ifxclone -T -L -S Amsterdam -I 192.168.0.1 -P 123 -t Berlin
-i 192.168.0.2 -p 456 -d RSS
```

Example 3, Adding an RS secondary server to a cluster

This example shows how to add an RS secondary server to the existing Informix high-availability cluster. The following values are used for this example:

- Source server name: Amsterdam
 - Source IP address: 192.168.0.1
 - Source port: 123
 - Target server name: Berlin
 - Target IP address: 192.168.0.2
 - Target port: 456
1. Create the onconfig and sqlhosts files and set the environment variables on the target computer.
 2. On the target server, log in as user informix and use the **touch**, **chown**, and **chmod** commands to create, change the owner, and set the permissions for the chunks. The chunk paths must match the paths of the chunks on the source server.
 3. On the target server, run the **ifxclone** utility:

```
ifxclone -T -L -S Amsterdam -I 192.168.0.1 -P 123 -t Berlin
-i 192.168.0.2 -p 456 -s medium -d RSS
```

Prerequisites for cloning an ER server

Complete the following prerequisites before attempting to clone an ER server.

1. The source server (that is, the server that is being cloned) must have ER configured and active.
2. For configuration parameters that specify directory names, the directory names must exist on the target server. For example, if the CDR_LOG_STAGING_DIR configuration parameter is set to a directory name on the source server then the directory must also exist on the target server.
3. If ATS or RIS is enabled on the source server then the appropriate ATS or RIS directories must exist on the target server. See Enabling ATS and RIS File Generation and Creating ATS and RIS Directories. If the directories do not exist then ATS/RIS spooling will fail.

4. If the source server has the CDR_SERIAL configuration parameter set then you must set the value for CDR_SERIAL to a different value on the server to be cloned. The value of CDR_SERIAL must be different on all replication servers. You can specify a unique value for the CDR_SERIAL configuration parameter by using the `--configParm (-c)` parameter in the `ifxclone` command line.
5. The clock on the new ER clone must be appropriately synchronized. See Time Synchronization.
6. The source server (that is, the server being cloned) must not have any stopped or suspended replicates, nor can it have any shadow replicates defined.

Avoid performing ER administrative tasks that change the set of replicates on which the target server participates while the `ifxclone` utility is running.

Example: Creating a clone of an ER server

Suppose you have five ER servers named S1, S2, S3, S4, and S5 currently configured as root servers in an ER domain. You would like to add a new server, S6, on a new computer named machine6, and you want it to have the same data as server S3.

1. Install and configure Informix database software on machine6. You can use the deployment utility to deploy a pre-configured database server instance.
2. Copy the `sqlhosts` file from server S3 to server S6 and modify it to add entries for the new server. For example, assuming the ER group name for the new server is `g_S6` and the ID is 60, the `sqlhosts` file lines would look like the following.

```
g_S6 group - - i=60
S6 onsoctcp machine6 service6 g=g_S6
```
3. Add the two lines from the previous step in the `sqlhosts` files on all of the other five servers (S1 through S5).
4. Copy the `onconfig` file from server S3 to server S6 and change the `DBSERVERNAME` configuration parameter to S6. Do not modify any storage or chunk parameters except for path information.
5. On server S6 (machine6) provision chunk paths and other storage to the same sizes as server S3. Ensure that S6 has adequate memory and disk space resources.
6. Run the following command as user **informix**:

```
ifxclone -L -S S3 -I machine3 -P service3 -t S6 -i machine6 -p service6 -d ER
```

 When prompted, enter the user name **informix** and then enter the password for user `informix`.
7. Monitor the server logs of servers S6 and S3. When the cloning process is complete you can check the status of servers by running the following command on servers S3 and S6:

```
cdr list server
```

You should see the new ER server `g_S6` connected to all of the other five servers. In addition, ER node `g_S6` will now participate in all replicates in which ER node `g_S3` participates.

Related reference:

“ENABLE_SNAPSHOT_COPY configuration parameter” on page 1-71

Chapter 20. The onspaces utility

Use the onspaces utility to manage the storage spaces in your database.

These topics show you how to use the following **onspaces** options:

- “onspaces -a: Add a chunk to a dbspace or blobspace” on page 20-2
- “onspaces -a: Add a chunk to an sbspace” on page 20-3
- “onspaces -c -b: Create a blobspace” on page 20-5
- “onspaces -c -d: Create a dbspace” on page 20-7
- “onspaces -c -S: Create an sbspace” on page 20-11
- “onspaces -c -x: Create an extspace” on page 20-16
- “onspaces -ch: Change sbspace default specifications” on page 20-17
- “onspaces -cl: Clean up stray smart large objects in sbspaces” on page 20-18
- “onspaces -d: Drop a chunk in a dbspace, blobspace, or sbspace” on page 20-19
- “onspaces -d: Drop a blobspace, dbspace, extspace, or sbspace” on page 20-20
- “onspaces -f: Specify DATASKIP parameter” on page 20-21
- “onspaces -m: Start mirroring” on page 20-22
- “onspaces -r: Stop mirroring” on page 20-24
- “onspaces -ren: Rename a dbspace, blobspace, sbspace, or extspace” on page 20-25
- “onspaces -s: Change status of a mirrored chunk” on page 20-26

When you use **onspaces** to manage a storage space, the database server updates information about the space in the **oncfg_servername.servernum** file. For more information on the **oncfg*** file, refer to Appendix A, “Files That the Database Server Uses,” on page A-1.

You can specify a maximum of 2047 chunks for a storage space, and a maximum of 2047 storage spaces on the database server system. The storage spaces can be any combination of dbspaces, blobspaces, and sbspaces.

On UNIX, you must be logged in as user **root** or user **informix** to execute **onspaces**. On Windows, you must be a member of the **Informix-Admin** group.

You cannot use the onspaces utility on High-Availability Data Replication (HDR) secondary servers, remote standalone (RS) secondary servers, or shared disk (SD) secondary servers.

You can use SQL administration API commands that are equivalent to **onspaces** commands.

onspaces Syntax

Element	Purpose	Key considerations
-m <i>pathname</i> <i>offset</i>	Specifies an optional path name and offset to the chunk that mirrors the new chunk. Also see the entries for <i>pathname</i> and <i>offset</i> in this table.	For more information, see adding a chunk to a dbspace or blobspace, in the chapter on managing disk space in the <i>IBM Informix Administrator's Guide</i> .
-o <i>offset</i>	After the -a option, <i>offset</i> indicates, in kilobytes, the offset into the disk partition or into the device to reach the initial chunk of the new blobspace or dbspace.	Unsigned integer. The starting offset must be equal to or greater than 0. The starting offset plus the chunk size cannot exceed the maximum chunk size. The maximum offset is 4 terabytes. For more information, see allocating raw disk space on UNIX in the chapter on managing disk space in the <i>IBM Informix Administrator's Guide</i> .
-p <i>pathname</i>	Indicates the disk partition or unbuffered device of the initial chunk of the blobspace or dbspace that you are adding. The chunk must be an existing unbuffered device or buffered file.	The chunk name can be up to 128 bytes. When you specify a path name, you can use either a full path name or a relative path name. However, if you use a relative path name, it must be relative to the directory that was the current directory when you initialized the database server. UNIX example (unbuffered device): /dev/rdisk/c0t3d0s4 UNIX example (buffered device): /ix/ids9.2/db1chunk Windows example: c:\Ifmxdata\ol_icecream\mychunk1.dat For path name syntax, see your operating-system documentation.
-s <i>size</i>	Indicates, in kilobytes, the size of the new blobspace or dbspace chunk.	Unsigned integer. The size must be equal to or greater than 1000 kilobytes and a multiple of the page size. The starting offset plus the chunk size cannot exceed the maximum chunk size. The maximum offset is 4 terabytes.
<i>blobspace</i>	Names the blobspace to which you are adding a chunk.	See adding a chunk to a blobspace in the chapter on managing disk space in the <i>IBM Informix Administrator's Guide</i> . Syntax must conform to the Identifier segment; see the <i>IBM Informix Guide to SQL: Syntax</i> .
<i>dbspace</i>	Names the dbspace to which you are adding a chunk.	See adding a chunk to a dbspace, in the chapter on managing disk space in the <i>IBM Informix Administrator's Guide</i> . Syntax must conform to the Identifier segment; see the <i>IBM Informix Guide to SQL: Syntax</i> .

This command has an equivalent SQL administration API function.

Related reference:

“Avoid overwriting a chunk” on page 20-28

“add chunk argument: Add a new chunk (SQL administration API)” on page 22-14

“create chunk argument: Create a chunk (SQL administration API)” on page 22-29

onspaces -a: Add a chunk to an sbpace

Syntax:

►► onspaces -a—*sbspace*— -p—*pathname*— -o—*offset*— -s—*size*—►►

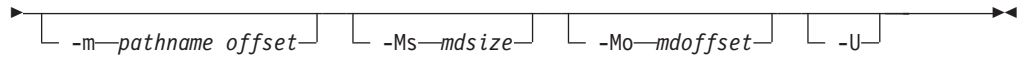

Use **onspaces -a** to add a chunk to an sbspace.

Element	Purpose	Key considerations
-a	Indicates that a chunk is to be added	You can have up to 32766 chunks in an instance. You can put all those chunks in one storage space, or spread them among multiple storage spaces.
-m pathname offset	Specifies an optional path name and offset to the chunk that mirrors the new chunk Also see the entries for <i>pathname</i> and <i>offset</i> in this table.	For background information, see adding a chunk to an sbspace, in the chapter on managing disk space in the <i>IBM Informix Administrator's Guide</i> .
-Mo mdoffset	Indicates, in kilobytes, the offset into the disk partition or into the device where metadata should be stored	Value can be an integer between 0 and the chunk size. You cannot specify an offset that causes the end of the metadata space to be past the end of the chunk. For background information, see sizing sbspace metadata, in the chapter on managing disk space in the <i>IBM Informix Administrator's Guide</i> .
-Ms mds size	Specifies the size, in kilobytes, of the metadata area allocated in the initial chunk. The remainder is user-data space	Value can be an integer between 0 and the chunk size. For background information, see sizing sbspace metadata, in the chapter on managing disk space in the <i>IBM Informix Administrator's Guide</i> .
-o offset	After the -a option, <i>offset</i> indicates, in kilobytes, the offset into the disk partition or into the unbuffered device to reach the initial chunk of the new blobspace or dbspace.	Unsigned integer. The starting offset must be equal to or greater than 0. The starting offset plus the chunk size cannot exceed the maximum chunk size. The maximum offset is 2 or 4 terabytes, depending on the platform. For more information, see allocating raw disk space on UNIX, in the chapter on managing disk space in the <i>IBM Informix Administrator's Guide</i> .
-p pathname	Indicates the disk partition or unbuffered device of the initial chunk of the sbspace that you are creating The chunk must be an existing unbuffered device or buffered file.	The chunk name can be up to 128 bytes. When you specify a path name, you can use either a full path name or a relative path name. However, if you use a relative path name, it must be relative to the directory that was the current directory when you initialized the database server. For path name syntax, see your operating-system documentation.
-U	Specifies that the entire chunk should be used to store user data	The -M and -U options are mutually exclusive. For background information, see adding a chunk to an sbspace, in the chapter on managing disk space in the <i>IBM Informix Administrator's Guide</i> .
-s size	Indicates, in kilobytes, the size of the new sbspace chunk	Unsigned integer. The size must be equal to or greater than 1000 kilobytes and a multiple of the page size. The starting offset plus the chunk size cannot exceed the maximum chunk size. The maximum offset is 4 terabytes

Element	Purpose	Key considerations
<i>sbspace</i>	Names the sbspace to which you are adding a chunk	See adding a chunk to an sbspace in the chapter on managing disk space in the <i>IBM Informix Administrator's Guide</i> . Syntax must conform to the Identifier segment; see the <i>IBM Informix Guide to SQL: Syntax</i> .

This command has an equivalent SQL administration API function.

Related reference:

“Avoid overwriting a chunk” on page 20-28

“add chunk argument: Add a new chunk (SQL administration API)” on page 22-14

“create chunk argument: Create a chunk (SQL administration API)” on page 22-29

onspaces -c -b: Create a blobspace

Syntax:

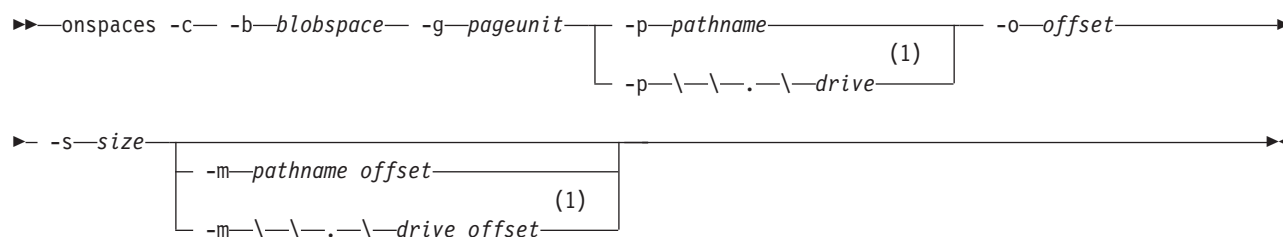

Notes:

- 1 Windows Only

Use **onspaces -c -b** to create a blobspace.

Element	Purpose	Key considerations
-b blobspace	Names the blobspace to be created	The blobspace name must be unique and cannot exceed 128 bytes. It must begin with a letter or underscore and must contain only letters, numbers, underscores, or the \$ character. For more information, see creating a blobspace, in the chapter on managing disk space in the <i>IBM Informix Administrator's Guide</i> . The syntax must conform to the Identifier segment. For more information, see the <i>IBM Informix Guide to SQL: Syntax</i> .
-c	Creates a dbspace, blobspace, sbspace, or extspace You can create up to 2047 storage spaces of any type.	After you create a storage space, you must back up both this storage space and the root dbspace. If you create a storage space with the same name as a deleted storage space, perform another level-0 backup to ensure that future restores do not confuse the new storage space with the old one. For more information, see creating a dbspace, blobspace, or extspace, in the chapter on managing disk space in the <i>IBM Informix Administrator's Guide</i> .

Element	Purpose	Key considerations
<i>drive</i>	Specifies the Windows drive to allocate as unbuffered disk space The format can be either <code>\\.\<drive></code> , where <i>drive</i> is the drive letter assigned to a disk partition, or <code>\\.\PhysicalDrive<number></code> , where <i>PhysicalDrive</i> is a constant value and <i>number</i> is the physical drive number.	For information on allocating unbuffered disk space, see allocating unbuffered disk space on Windows in the chapter on managing disk space in the <i>IBM Informix Administrator's Guide</i> . Examples: <code>\\.\F:</code> <code>\\.\PhysicalDrive2</code> For path name syntax, see your operating-system documentation.
-g pageunit	Specifies the blobpage size in terms of <i>page_unit</i> , the number of the base page size of the instance (either 2K or 4K)	Unsigned integer. Value must be greater than 0. The maximum number of pages that a blobpage can contain is 2147483647. Therefore, the size of the blobpage is limited to the blobpage size x 2147483647. This includes blobpages in all chunks that make up the blobpage. For more information, see blobpage size considerations, in the chapter on I/O Activity in the <i>IBM Informix Performance Guide</i> .
-m pathname offset	Specifies an optional path name and offset to the chunk that mirrors the initial chunk of the new blobpage or dbpage Also see the entries for -p pathname and -o offset in this table.	For more information, see creating a dbpage or a blobpage in the chapter on managing disk space in the <i>IBM Informix Administrator's Guide</i> .
-o offset	Indicates, in kilobytes, the offset into the disk partition or into the device to reach the initial chunk of the new blobpage, dbpage, or sbpage	Unsigned integer. The starting offset must be equal to or greater than 0. The starting offset plus the chunk size cannot exceed the maximum chunk size. The maximum offset is 2 or 4 terabytes, depending on the platform. For more information, see allocating raw disk space, in the chapter on managing disk space in the <i>IBM Informix Administrator's Guide</i> .
-p pathname	Indicates the disk partition or device of the initial chunk of the blobpage or dbpage that you are creating	The chunk must be an existing unbuffered device or buffered file. When you specify a path name, you can use either a full path name or a relative path name. However, if you use a relative path name, it must be relative to the directory that was the current directory when you initialized the database server. UNIX example (unbuffered device): <code>/dev/rdisk/c0t3d0s4</code> UNIX example (buffered device): <code>/ix/ids9.2/db1chunk</code> Windows example: <code>c:\Ifmxdata\ol_icecream\mychunk1.dat</code> For path name syntax, see your operating-system documentation.
-s size	Indicates, in kilobytes, the size of the initial chunk of the new blobpage or dbpage	Unsigned integer. The size must be equal to or greater than 1000 kilobytes and a multiple of the page size. The starting offset plus the chunk size cannot exceed the maximum chunk size. The maximum chunk size is 2 or 4 terabytes, depending on the platform.

This command has an equivalent SQL administration API function.

Related reference:

“Avoid overwriting a chunk” on page 20-28

“create blobspace argument: Create a blobspace (SQL administration API)” on page 22-26

onspaces -c -d: Create a dbspace

Use the **onspaces -c -d** option to create a dbspace or a temporary dbspace.

Syntax:

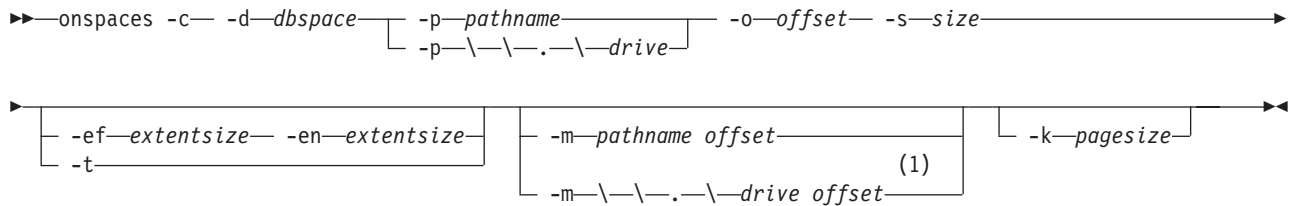

Notes:

1 Windows Only

Element	Purpose	Key considerations
-c	Creates a dbspace You can create up to 2047 storage spaces of any type.	After you create a storage space, you must back up both this storage space and the root dbspace. If you create a storage space with the same name as a deleted storage space, perform another level-0 backup to ensure that future restores do not confuse the new storage space with the old one. For more information, see Manage dbspaces (Administrator's Guide).
<i>drive</i>	Specifies the Windows drive to allocate as unbuffered disk space The format can be either \\.\< <i>drive</i> >, where <i>drive</i> is the drive letter assigned to a disk partition, or \\.\< <i>PhysicalDrive</i> < <i>number</i> >, where <i>PhysicalDrive</i> is a constant value and <i>number</i> is the physical drive number.	For information on allocating unbuffered disk space, see Allocating raw disk space on Windows (Administrator's Guide). Examples: \\.\F: \\.\PhysicalDrive2 okay For path name syntax, see your operating-system documentation.
-d <i>dbspace</i>	Names the dbspace to be created	The dbspace name must be unique and cannot exceed 128 bytes. It must begin with a letter or underscore and must contain only letters, numbers, underscores, or the \$ character. For more information, see Manage dbspaces (Administrator's Guide). The syntax must conform to the Identifier segment. For more information, see the <i>IBM Informix Guide to SQL: Syntax</i> .

Element	Purpose	Key considerations
-ef extentsize	Indicates, in kilobytes, the size of the first extent for the tblspace	<p>The minimum, and default, size of the first extent for the tblspace of a non-root dbpace is equivalent to 50 dbpace pages, specified in K. For example: 100 KB for a 2 KB page size dbpace, 200 KB for a 4 KB page size dbpace, 400 KB for an 8 KB page size dbpace.</p> <p>The maximum size of a tblspace extent is 1048575 pages minus the space needed for any system objects. On a 2 KB pagesize system this would evaluate to approximately 2 GB.</p> <p>For more information, see Specifying the first and next extent sizes for the tblspace (Administrator's Guide).</p>
-en extentsize	Indicates, in kilobytes, the size of the next extents in the tblspace	<p>The minimum size of the next extents for the tblspace of a non-root dbpace is equivalent to 4 dbpace pages, specified in K. For example: 8 KB for a 2 KB page size dbpace, 16 KB for a 4 KB page size dbpace, 32 KB for an 8 KB page size dbpace.</p> <p>The default size for a next extent is 50 dbpace pages.</p> <p>The maximum size of a tblspace extent is 1048572 pages. On a 2 KB pagesize system this would evaluate to approximately 2 GB.</p> <p>If there is not enough space for a next extent in the primary chunk, the extent is allocated from another chunk. If the specified space is not available, the closest available space is allocated.</p> <p>For more information, see Specifying the first and next extent sizes for the tblspace (Administrator's Guide).</p>
-k pagesize	<p>Indicates in kilobytes, the non-default page size for the new dbpace.</p> <p>For systems with sufficient storage, performance advantages of a larger page size can include the following:</p> <ul style="list-style-type: none"> • Reduced depth of B-tree indexes, even for smaller index keys • You can group on the same page long rows that currently span multiple pages of the default page size • Checkpoint time is typically reduced with larger pages • You can define a different page size for temporary tables, so that they have a separate buffer pool. 	<p>The page size must be between 2KB and 16KB and must be a multiple of the default page size. For example, if the default page size is 2KB, then <i>pagesize</i> can be 2, 4, 6, 8, 10, 12, 14, or 16. If the default page size is 4KB (Windows), then <i>pagesize</i> can be 4, 8, 12, or 16.</p> <p>For more information, see Creating a dbpace with a non-default page size (Administrator's Guide).</p>

Element	Purpose	Key considerations
-m <i>pathname offset</i>	Specifies an optional path name and offset to the chunk that mirrors the initial chunk of the new dbspace Also see the entries for -p <i>pathname</i> and -o <i>offset</i> in this table.	For more information, see Manage dbspaces (Administrator's Guide).
-o <i>offset</i>	Indicates, in kilobytes, the offset into the disk partition or into the device to reach the initial chunk of the new dbspace	Unsigned integer. The starting offset must be equal to or greater than 0. The starting offset plus the chunk size cannot exceed the maximum chunk size. The offset must be a multiple of the page size. The maximum offset is 2 or 4 terabytes, depending on the platform. For more information, see Allocating raw disk space on Windows (Administrator's Guide).
-p <i>pathname</i>	Indicates the disk partition or device of the initial chunk of the dbspace that you are creating	The chunk must be an existing unbuffered device or buffered file. When you specify a path name, you can use either a full path name or a relative path name. However, if you use a relative path name, it must be relative to the directory that was the current directory when you initialized the database server. UNIX example (unbuffered device): /dev/rdisk/c0t3d0s4 UNIX example (buffered device): /ix/ids9.2/db1chunk Windows example:c:\Ifmldata\ol_icecream\mychunk1.dat For path name syntax, see your operating-system documentation.
-s <i>size</i>	Indicates, in kilobytes, the size of the initial chunk of the new dbspace	Unsigned integer. The size must be equal to or greater than 1000 kilobytes and a multiple of the page size. The starting offset plus the chunk size cannot exceed the maximum chunk size. The maximum chunk size is 2 or 4 terabytes, depending on the platform.
-t	Creates a temporary dbspace for storage of temporary tables	You cannot mirror a temporary dbspace. You cannot specify the first and next extent sizes for the tblspace of a temporary dbspace. For more information, see Temporary dbspaces (Administrator's Guide).

The maximum size of a dbspace is equal to the maximum number of chunks multiplied by the maximum size of a chunk. (The maximum number of chunks is 32766 per instance. The maximum size of a chunk is equal to 2147483647 pages multiplied by the page size.)

This command has an equivalent SQL administration API function.

Related reference:

“Avoid overwriting a chunk” on page 20-28

“create dbspace argument: Create a dbspace (SQL administration API)” on page 22-32

“create tempdbspace argument: Create a temporary dbspace (SQL administration API)” on page 22-38

“BUFFERPOOL configuration parameter” on page 1-36

Creating a temporary dbspace with the `onspaces -t` command

When you create a temporary dbspace with `onspaces`, the database server uses the newly created temporary dbspace, after you perform the following steps:

1. Add the name of the new temporary dbspace to your list of temporary dbspaces in the `DBSPACETEMP` configuration parameter, the `DBSPACETEMP` environment variable, or both.
2. Restart the database server.

Use `create tempdbspace` as the SQL administration API *command* string for `onspaces -c -d -t`.

Specifying first and next extent sizes

You cannot specify the first and next extent of a temporary dbspace. You can specify the first and next space of the tblspace `tblspace` in the root dbspace if you do not want the database server to automatically manage the size.

The extent size for temporary dbspaces is 100 kilobytes for a 2 kilobyte page system or 200 kilobytes for a 4 kilobyte page system.

To specify the first and next extent sizes of a root tblspace `tblspace`, use the `TBLTBLFIRST` and `TBLTBLNEXT` configuration parameters before you create the root dbspace the first time you start the database server.

Related tasks:

[➤](#) Specifying the first and next extent sizes for the tblspace `tblspace` (Administrator's Guide)

Related reference:

[➤](#) `TBLTBLFIRST` configuration parameter (Administrator's Reference)

[➤](#) `TBLTBLNEXT` configuration parameter (Administrator's Reference)

Specifying a Non-Default Page Size with the Same Size as the Buffer Pool

When you create a dbspace with a non-default page size, you must also create a buffer pool specific to that page size. It is recommended that you create the buffer pool before you create the dbspace. Use the `onparams` utility to create a buffer pool. For more information, see “`onparams -b`: Add a new buffer pool” on page 17-4.

When you add a dbspace with a different page size with the `onspaces` utility or you add a new buffer pool (with the `onparams` utility), a new `BUFFERPOOL` line is appended in the `BUFFERPOOL` configuration parameter in the `ONCONFIG` file to reflect the new entry and it is rewritten to disk.

Notes:

1. You cannot change the page size of a dbspace after you create it.
2. You cannot store logical or physical logs in a dbspace that is not the default platform page size.
3. If a dbspace is created when a buffer pool with that page size does not exist, Informix creates a buffer pool using the values of the fields of the default line of the BUFFERPOOL parameter. You cannot have multiple buffer pools with the same page size.

Related reference:

“BUFFERPOOL configuration parameter” on page 1-36

onspaces -c -S: Create an sbspace

Use the **onspaces -c -S** option to create a sbspace or a temporary sbspace.

Syntax:

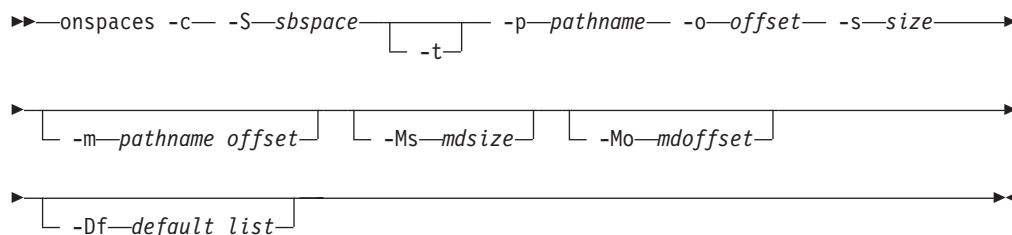

Element	Purpose	Key Considerations
-S <i>sbspace</i>	Names the sbspace to be created	The sbspace name must be unique and must not exceed 128 bytes. It must begin with a letter or underscore and must contain only letters, numbers, underscores, or the \$ character. Syntax must conform to the Identifier segment; see the <i>IBM Informix Guide to SQL: Syntax</i> .
-c	Creates an sbspace You can create up to 32767 storage spaces of any type.	None.
-m <i>pathname offset</i>	Specifies an optional pathname and offset to the chunk that mirrors the initial chunk of the new sbspace Also see the entries for -p <i>pathname</i> and -o <i>offset</i> in this table.	For more information, see sbspaces in the chapter on data storage, and creating an sbspace, in the chapter on managing disk space in the <i>IBM Informix Administrator's Guide</i> .
-Mo <i>mdoffset</i>	Indicates, in kilobytes, the offset into the disk partition or into the device where metadata will be stored.	Restrictions: Value can be an integer between 0 and the chunk size. You cannot specify an offset that causes the end of the metadata space to be past the end of the chunk. References: For more information, see sizing sbspace metadata, in the chapter on managing disk space in the <i>IBM Informix Administrator's Guide</i> .

Element	Purpose	Key Considerations
-Ms mdsiz	Specifies the size, in kilobytes, of the metadata area allocated in the initial chunk The remainder is user-data space.	Restrictions: Value can be an integer between 0 and the chunk size.
-o offset	Indicates, in kilobytes, the offset into the disk partition or into the device to reach the initial chunk of the sbspace	Restrictions: Unsigned integer. The starting offset must be equal to or greater than 0. The starting offset plus the chunk size cannot exceed the maximum chunk size. The maximum chunk size is 4 terabytes for systems with a two-kilobyte page size and 8 terabytes for systems with a four-kilobyte page size. References: For more information, see allocating raw disk space on UNIX, in the chapter on managing disk space in the <i>IBM Informix Administrator's Guide</i> .
-p pathname	Indicates the disk partition or unbuffered device of the initial chunk of the sbspace	The chunk must be an existing unbuffered device or buffered file. When you specify a pathname, you can use either a full pathname or a relative pathname. However, if you use a relative pathname, it must be relative to the directory that was the current directory when you initialized the database server. References: For pathname syntax, see your operating-system documentation.
-s size	Indicates, in kilobytes, the size of the initial chunk of the new sbspace	Restrictions: Unsigned integer. The size must be equal to or greater than 1000 kilobytes and a multiple of the page size. The starting offset plus the chunk size cannot exceed the maximum chunk size. The maximum chunk size is 2 or 4 terabytes, depending on the platform.
-t	Creates a temporary sbspace for storage of temporary smart large objects. You can specify the size and offset of the metadata area	Restrictions: You cannot mirror a temporary sbspace. You can specify any -Df option, except the LOGGING=ON option, which has no effect. References: For more information, see "Creating a Temporary Sbspace with the -t Option" on page 20-13.
-Df default list	Lists default specifications for smart large objects stored in the sbspace	Restrictions: Tags are separated by commas. If a tag is not present, system defaults take precedence. The list must be enclosed in double quotation marks (") on the command line. References: For a list of tags and their parameters, see Table 20-1 on page 20-13.

Related reference:

“Avoid overwriting a chunk” on page 20-28

“create sbspace argument: Create an sbspace (SQL administration API)” on page 22-34

“create tempsbpace argument: Create a temporary sbspace (SQL administration API)” on page 22-40

“create sbspace with log argument: Create an sbspace with transaction logging (SQL administration API)” on page 22-37

Creating a Temporary Sbspace with the -t Option

This example creates a temporary sbspace of 1000 kilobytes:

```
onspaces -c -S tempsbsp -t -p ./tempsbsp -o 0 -s 1000
```

You can optionally specify the name of the temporary sbspace in the SBSPACETEMP configuration parameter. Restart the database server so that it can use the temporary sbspace.

Creating an Sbspace with the -Df option

When you create an sbspace with the optional **-Df** option, you can specify several default specifications that affect the behavior of the smart large objects stored in the sbspace. The default specifications must be expressed as a list separated by commas. The list need not contain all of the tags. The list of tags must be enclosed in double quotation marks (“”). The table in Table 20-1 describes the tags and their default values.

The four levels of inheritance for sbspace characteristics are system, sbspace, column, and smart large objects. For more information, see smart large objects in the chapter on where data is stored in the *IBM Informix Administrator's Guide*.

Table 20-1. -Df Default Specifications

Tag	Values	Default	Description
ACCESSTIME	ON or OFF	OFF	When set to ON, the database server tracks the time of access to all smart large objects stored in the sbspace. For information about altering storage characteristics of smart large objects, see the <i>IBM Informix DataBlade API Programmer's Guide</i> .

Table 20-1. -Df Default Specifications (continued)

Tag	Values	Default	Description
AVG_LO_SIZE	Windows: 4 to 2**31 UNIX: 2 to 2**31	8	<p>Specifies the average size, in kilobytes, of the smart large object stored in the sbspace</p> <p>The database server uses this value to calculate the size of the metadata area. Do not specify AVG_LO_SIZE and -Ms together. You can specify AVG_LO_SIZE and the metadata offset (-Mo) together.</p> <p>If the size of the smart large object exceeds 2**31, specify 2**31. If the size of the smart large object is less than 2 on UNIX or less than 4 in Windows, specify 2 or 4.</p> <p>Error 131 is returned if you run out of space in the metadata and reserved areas in the sbspace. To allocate additional chunks to the sbspace that consist of metadata area only, use the -Ms option instead.</p> <p>For more information, see creating smart large objects, in the chapter on managing data on disk in the <i>IBM Informix Administrator's Guide</i>.</p>
BUFFERING	ON or OFF	ON	<p>Specifies the buffering mode of smart large objects stored in the sbspace</p> <p>If set to ON, the database server uses the buffer pool in the resident portion of shared memory for smart-large-object I/O operations. If set to OFF, the database server uses light I/O buffers in the virtual portion of shared memory (lightweight I/O operations).</p> <p>BUFFERING = OFF is incompatible with LOCK_MODE = RANGE and creates a conflict</p> <p>For more information, see lightweight I/O, in the chapter on configuration effects on memory in the <i>IBM Informix Performance Guide</i>.</p>
LOCK_MODE	RANGE or BLOB	BLOB	<p>Specifies the locking mode of smart large objects stored in the sbspace</p> <p>If set to RANGE, only a range of bytes in the smart large object is locked. If set to BLOB, the entire smart large object is locked.</p> <p>LOCK_MODE = RANGE is incompatible with BUFFERING = OFF and creates a conflict.</p> <p>For more information, see smart large objects, in the chapter on locking in the <i>IBM Informix Performance Guide</i>.</p>

Table 20-1. -Df Default Specifications (continued)

Tag	Values	Default	Description
LOGGING	ON or OFF	OFF	<p>Specifies the logging status of smart large objects stored in the sbspace</p> <p>If set to ON, the database server logs changes to the user data area of the sbspace. When you turn on logging for an sbspace, take a level-0 backup of the sbspace.</p> <p>When you turn off logging, the following message displays: You are turning off smart large object logging.</p> <p>For more information, see smart large objects, in the chapters on data storage and logging in the <i>IBM Informix Administrator's Guide</i>. For information about onspaces -ch messages, see Appendix E, "Error Messages," on page E-1.</p>
EXTENT_SIZE	4 to 2**31	None	<p>Specifies the size, in kilobytes, of the first allocation of disk space for smart large objects stored in the sbspace when you create the table</p> <p>Let the system select the EXTENT_SIZE value. To reduce the number of extents in a smart large object, use mi_lo_specset_estbytes (DataBlade API) or ifx_lo_specset_estbytes (Informix ESQL/C) to hint to the system the total size of the smart large object. The system attempts to allocate a single extent for the smart large object.</p> <p>For more information, see smart large objects, in the chapter on where data is stored in the <i>IBM Informix Administrator's Guide</i>. For information about altering storage characteristics of smart large objects, see the <i>IBM Informix DataBlade API Programmer's Guide</i> or the <i>IBM Informix ESQL/C Programmer's Manual</i>.</p>
MIN_EXT_SIZE	2 to 2**31	Windows: 4UNIX: 2	<p>Specifies the minimum amount of space, in kilobytes, to allocate for each smart large object</p> <p>The following message displays: Changing the sbspace minimum extent size: old value <i>value1</i> new value <i>value2</i>.</p> <p>For information about tuning this value, see smart large objects, in the chapter on configuration effects on I/O utilization in the <i>IBM Informix Performance Guide</i>. For information about onspaces -ch messages, see Appendix E, "Error Messages," on page E-1.</p>
NEXT_SIZE	4 to 2**31	None	<p>Specifies the extent size, in kilobytes, of the next allocation of disk space for smart large objects when the initial extent in the sbspace becomes full. Let the system select the NEXT_SIZE value. To reduce the number of extents in a smart large object, use mi_lo_specset_estbytes or ifx_lo_specset_estbytes to hint to the system the total size of the smart large object. The system attempts to allocate a single extent for the smart large object.</p> <p>For more information, see smart large objects, in the chapter on where data is stored in the <i>IBM Informix Administrator's Guide</i>. For information about obtaining the size of smart large objects, see the <i>IBM Informix DataBlade API Programmer's Guide</i> or the <i>IBM Informix ESQL/C Programmer's Manual</i>.</p>

This example creates a 20-megabyte mirrored sbsp, **eg_sbsp**, with the following specifications:

- An offset of 500 kilobytes for the primary and mirror chunks
- An offset of 200 kilobytes for the metadata area
- An average expected smart-large-object size of 32 kilobytes
- Log changes to the smart large objects in the user-data area of the sbsp

UNIX Only:

```
% onspaces -c -S eg_sbsp -p /dev/raw_dev1 -o 500 -s 20000  
-m /dev/raw_dev2 500 -Mo 200 -Df "AVG_LO_SIZE=32,LOGGING=ON"
```

Changing the -Df Settings

As the database server administrator, you can override or change the **-Df** default settings in one of the following ways:

- To change the default settings for an sbsp, use the **onspaces -ch** option. For more information, refer to “onspaces -ch: Change sbsp default specifications” on page 20-17.
- To override the following **-Df** default settings for a specific table, use the SQL statements CREATE TABLE or ALTER TABLE:
 - LOGGING
 - ACESSTIME
 - EXTENT_SIZE
 - NEXT_SIZE

For more information on the ALTER TABLE and CREATE TABLE statements, see the *IBM Informix Guide to SQL: Syntax*.

The programmer can override these **-Df** default settings with DataBlade API and Informix ESQ/C functions. For information about altering storage characteristics of smart large objects, see the *IBM Informix DataBlade API Programmer's Guide* and the *IBM Informix ESQ/C Programmer's Manual*.

Using the onspaces -g option

The **onspaces -g** option is not used for sbsp. The database server uses a different method to determine the number of pages to transfer in an I/O operation for sbsp than for blobspaces. The database server can automatically determine the block size to transfer in an I/O operation for smart large objects. For more information, see sbsp extent sizes in the chapter on I/O activity in your *IBM Informix Performance Guide*.

This command has an equivalent SQL administration API function.

onspaces -c -x: Create an extspace

Use the **onspaces -c -x** option to create an extspace.

Syntax:

```
►► onspaces -c -x extspace -l location -o offset -s size ◀◀
```

Element	Purpose	Key Considerations
-c	Creates a dbspace, blobspace, sbspace, or extspace You can create up to 2047 storage spaces of any type.	After you create a storage space, you must back up both this storage space and the root dbspace. If you create a storage space with the same name as a deleted storage space, perform another level-0 backup to ensure that future restores do not confuse the new storage space with the old one. For more information, see creating a dbspace, blobspace, or extspace, in the chapter on managing disk space in the <i>IBM Informix Administrator's Guide</i> .
-l <i>location</i>	Specifies the location of the extspace The access method determines the format of this string.	Restrictions: String. Value must not be longer than 255 bytes. For more information, see creating an extspace, in the chapter on managing disk space in the <i>IBM Informix Administrator's Guide</i> .
-o <i>offset</i>	Indicates, in kilobytes, the offset into the disk partition or into the device to reach the initial chunk of the new blobspace, dbspace, or sbspace	Restrictions: Unsigned integer. The starting offset must be equal to or greater than 0. The starting offset plus the chunk size cannot exceed the maximum chunk size. The maximum offset is 2 or 4 terabytes, depending on the platform. For more information, see allocating raw disk space, in the chapter on managing disk space in the <i>IBM Informix Administrator's Guide</i> .
-s <i>size</i>	Indicates, in kilobytes, the size of the initial chunk of the new blobspace or dbspace	Restrictions: Unsigned integer. The size must be equal to or greater than 1000 kilobytes and a multiple of the page size. The starting offset plus the chunk size cannot exceed the maximum chunk size. The maximum chunk size is 2 or 4 terabytes, depending on the platform.
-x <i>extspace</i>	Names the extspace to be created	Restrictions: Extspace names can be up to 128 bytes. They must be unique, begin with a letter or underscore, and contain only letters, digits, underscores, or \$ characters. For more information, see extspaces, in the chapter on managing disk space in the <i>IBM Informix Administrator's Guide</i> .

onspaces -ch: Change sbspace default specifications

Use the **onspaces -ch** option to change the default specifications of a sbspace.

Syntax:

►► onspaces -ch—*sbspace*— -Df—*default list*—◀◀

Element	Purpose	Key Considerations
-ch	Indicates that one or more sbspace default specifications are to be changed	None.

Element	Purpose	Key Considerations
<i>sbspace</i>	Names the sbspace for which to change the default specifications	Syntax must conform to the Identifier segment; see the <i>IBM Informix Guide to SQL: Syntax</i> . For background information, see changing default specifications of an sbspace with onspaces in the <i>IBM Informix Performance Guide</i> .
-Df default list	Lists new default specifications for smart large objects stored in the sbspace	Tags are separated by commas. If a tag is not present, system defaults take precedence. The list must be enclosed in double quotation marks (") on the command line. For a list of tags and their parameters, see Table 20-1 on page 20-13.

You can change any of the **-Df** tags with the **onspaces -ch** option. The database server applies the change to each smart large object that was created prior to changing the default specification.

For example, to turn off logging for the sbspace that you created in “Creating an Sbspace with the **-Df** option” on page 20-13, use the following command:

```
onspaces -ch eg_sbsp -Df "LOGGING=OFF"
```

Note: After you turn on logging for an sbspace, take a level-0 backup of the sbspace to create a point from which to recover.

Related reference:

“set sbspace accesstime argument: Control access time tracking (SQL administration API)” on page 22-110

“set sbspace avg_lo_size argument: Set the average size of smart large objects (SQL administration API)” on page 22-111

“set sbspace logging argument: Change the logging of an sbspace (SQL administration API)” on page 22-112

onspaces -cl: Clean up stray smart large objects in sbspaces

Use the **onspaces -cl** option to clean up stray smart large objects in sbspaces.

Syntax:

```
▶▶—onspaces -cl—sbspace—◀◀
```

Element	Purpose	Key Considerations
-cl	Cleans up stray smart large objects in an sbspace	To find any stray smart large objects, use the oncheck -pS command when no users are connected to the database server. The smart large objects with a reference count of 0 are stray objects.
<i>sbspace</i>	Names the sbspace to be cleaned up	Syntax must conform to the Identifier segment; see the <i>IBM Informix Guide to SQL: Syntax</i> .

During normal operation, no unreferenced (stray) smart large objects should exist. When you delete a smart large object, the space is released. If the database server fails or runs out of system memory while you are deleting a smart large object, the smart large object might remain as a stray object.

The following is an example of the **onspaces -cl** command:

```
onspaces -cl myspace
```

The best way to find the reference count for a smart large object is to call the **mi_lo_stat** or **ifx_lo_stat** functions from a C program. Although the **mi_lo_increfcount** and **mi_lo_decrefcount** functions return the reference count, they increment or decrement the reference count. For more information on these functions, see the *IBM Informix DataBlade API Function Reference*.

This command has an equivalent SQL administration API function.

Related reference:

“clean sbspace argument: Release unreferenced smart large objects (SQL administration API)” on page 22-26

onspaces -d: Drop a chunk in a dbspace, blobspace, or sbspace

Use the **onspaces -d** option to drop a chunk in a dbspace, blobspace, or sbspace.

Syntax:

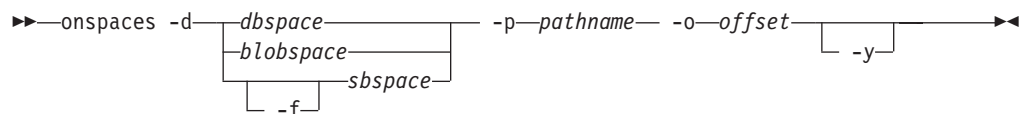

This command has an equivalent SQL administration API function.

Element	Purpose	Key considerations
-d	Drops a chunk	<p>You can drop a chunk from a dbspace, temporary dbspace, or sbspace when the database server is online or quiescent. For more information, see the chapter on managing disk space in the <i>IBM Informix Administrator's Guide</i>.</p> <p>You can drop a chunk from a blobspace only when the database server is in quiescent mode.</p>
-f	Drops an sbspace chunk that contains user data but no metadata. If the chunk contains metadata for the sbspace, you must drop the entire sbspace.	<p>Use the -f option with sbspaces only. If you omit the -f option, you cannot drop an sbspace that contains data.</p> <p>For more information, see dropping a chunk from an sbspace with onspaces, in the chapter on managing disk space in the <i>IBM Informix Administrator's Guide</i>.</p>
-o offset	Indicates, in kilobytes, the offset into the disk partition or into the unbuffered device to reach the initial chunk of the dbspace, blobspace, or sbspace that you are dropping	<p>Restrictions: Unsigned integer. The starting offset must be equal to or greater than 0. The starting offset plus the chunk size cannot exceed the maximum chunk size.</p> <p>The maximum offset is 4 terabytes.</p> <p>For more information, see allocating raw disk space on UNIX, in the chapter on managing disk space in the <i>IBM Informix Administrator's Guide</i>.</p>

Element	Purpose	Key considerations
-p pathname	Indicates the disk partition or unbuffered device of the initial chunk of the dbspace, blobspace, or sbspace that you are dropping	The chunk must be an existing unbuffered device or buffered file. When you specify a path name, you can use either a full path name or a relative path name. However, if you use a relative path name, it must be relative to the directory that was the current directory when you initialized the database server. For path name syntax, see your operating-system documentation.
-y	Causes the database server to automatically respond yes to all prompts	None.
blobspace	Names the blobspace from which the chunk is dropped	Syntax must conform to the Identifier segment; see the <i>IBM Informix Guide to SQL: Syntax</i> . For more information, see dropping a chunk from a blobspace, in the chapter on managing disk space in the <i>IBM Informix Administrator's Guide</i> .
dbspace	Names the dbspace from which the chunk is dropped	Syntax must conform to the Identifier segment; see the <i>IBM Informix Guide to SQL: Syntax</i> . For more information, see dropping a chunk from a dbspace with onspaces , in the chapter on managing disk space in the <i>IBM Informix Administrator's Guide</i> .
sbspace	Names the sbspace from which the chunk is dropped	Syntax must conform to the Identifier segment; see the <i>IBM Informix Guide to SQL: Syntax</i> . For background information, see dropping a chunk from a sbspace with onspaces , in the chapter on managing disk space in the <i>IBM Informix Administrator's Guide</i> .

Important: You must specify a path name to indicate to the database server that you are dropping a chunk.

Related reference:

“drop chunk argument: Drop a chunk (SQL administration API)” on page 22-44

onspaces -d: Drop a blobspace, dbspace, extspace, or sbspace

Use the **onspaces -d** option to drop a dbspace, blobspace, sbspace, or extspace.

Syntax:

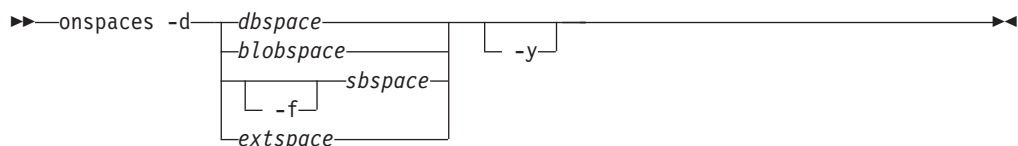

This command has an equivalent SQL administration API function.

Element	Purpose	Key considerations
-d	Indicates that a dbspace, blobspace, sbspace, or extspace is to be dropped	You can drop a dbspace, blobspace, sbspace, or extspace while the database server is online or in quiescent mode. After you drop a storage space, you must back it up to ensure that the sysutils database and the reserved pages are up-to-date. Execute oncheck -pe to verify that no table is currently storing data in the dbspace, blobspace, or sbspace. For more information, see dropping a storage space, in the chapter on managing disk space in the <i>IBM Informix Administrator's Guide</i> .
-y	Causes the database server to automatically respond yes to all prompts	None.
-f	Drops an sbspace that contains user data and metadata	You must use the -f (force) option to drop an sbspace that contains data. Restriction: Use the -f option with sbspaces only. Warning: If you use the -f option, the tables in the database server might have dead pointers to the smart large objects that were deleted with this option. For more information, see dropping a chunk from an sbspace with onspaces , in the chapter on managing disk space in the <i>IBM Informix Administrator's Guide</i> .
<i>blobspace</i>	Names the blobspace to be dropped	Before you drop a blobspace, drop all tables that include a TEXT or BYTE column that references the blobspace.
<i>dbspace</i>	Names the dbspace to be dropped	Before you drop a dbspace, drop all databases and tables that you previously created in the dbspace.
<i>extspace</i>	Names the extspace to be dropped	You cannot drop an extspace if it is associated with an existing table or index.
<i>sbspace</i>	Names the sbspace to be dropped	Before you drop an sbspace, drop all tables that include a BLOB or CLOB column that references the sbspace.

Important: Do not specify a path name when you drop these storage spaces.

Related reference:

“drop blobspace argument: Drop a blobspace (SQL administration API)” on page 22-43

“drop dbspace argument: Drop a dbspace (SQL administration API)” on page 22-47

“drop sbspace argument: Drop an sbspace (SQL administration API)” on page 22-49

“drop tempdbspace argument: Drop a temporary dbspace (SQL administration API)” on page 22-50

onspaces -f: Specify DATASKIP parameter

Use the **onspaces -f** option to specify the value of the DATASKIP configuration parameter on a dbspace level or across all dbspaces.

Syntax:

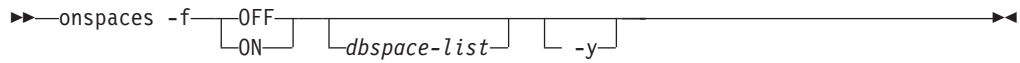

This command has an equivalent SQL administration API function.

Element	Purpose	Key considerations
-f	Indicates to the database server that you want to change the DATASKIP default for specified dbspaces or all dbspaces	All changes in the DATASKIP status are recorded in the message log.
-y	Causes the database server to automatically respond yes to all prompts	None.
dbspace-list	Specifies the name of one or more dbspaces for which DATASKIP will be turned ON or OFF	Syntax must conform to the Identifier segment; see the <i>IBM Informix Guide to SQL: Syntax</i> . For more information, see "DATASKIP Configuration Parameter" on page 1-42 and the <i>IBM Informix Performance Guide</i> .
OFF	Turns off DATASKIP	If you use OFF without <i>dbspace-list</i> , DATASKIP is turned off for all fragments. If you use OFF with <i>dbspace-list</i> , only the specified fragments are set with DATASKIP off.
ON	Turns on DATASKIP	If you use ON without <i>dbspace-list</i> , DATASKIP is turned on for all fragments. If you use ON with <i>dbspace-list</i> , only the specified fragments are set with DATASKIP on.

Related reference:

"set dataskip argument: Start or stop skipping a dbspace (SQL administration API)" on page 22-107

"DATASKIP Configuration Parameter" on page 1-42

onspaces -m: Start mirroring

Use the **onspaces -m** option to start mirroring for a dbspace, blobspace, or sbspace.

Syntax:

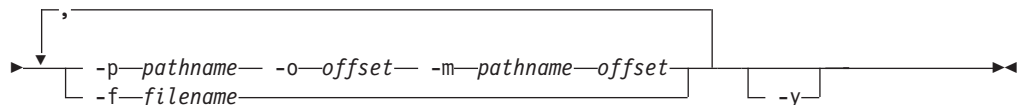

This command has an equivalent SQL administration API function.

Element	Purpose	Key considerations
-f filename	Indicates that chunk-location information is in a file named <i>filename</i>	The file must be a buffered file that already exists. The path name must conform to the operating-system-specific rules for path names. For more information, see “Using a File to Specify Chunk-Location Information with the -f Option” on page 20-24.
-m	Adds mirroring for an existing dbspace, blobspace, or sbspace	User-data chunks in a mirrored sbspace need not be mirrored. The mirrored chunks should be on a different disk. You must mirror all the chunks at the same time.
-m pathname offset	The second time that <i>pathname</i> occurs in the syntax diagram, it indicates the disk partition or unbuffered device of the initial chunk of the dbspace, blobspace, or sbspace that performs the mirroring. The second time <i>offset</i> appears in the syntax diagram, it indicates the offset to reach the mirrored chunk of the newly mirrored dbspace, blobspace, or sbspace. Also see the entries for <i>pathname</i> and <i>offset</i> in this table.	None.
-o offset	The first time that <i>offset</i> occurs in the syntax diagram, it indicates, in kilobytes, the offset into the disk partition or into the unbuffered device to reach the initial chunk of the newly mirrored dbspace, blobspace, or sbspace.	Restrictions: Unsigned integer. The starting offset must be equal to or greater than 0. The starting offset plus the chunk size cannot exceed the maximum chunk size. The maximum offset is 4 terabytes. For more information, see allocating raw disk space on UNIX, in the chapter on managing disk space in the <i>IBM Informix Administrator's Guide</i> .
-p pathname	The first time <i>pathname</i> occurs in the syntax diagram, it indicates the disk partition or unbuffered device of the initial chunk of the dbspace, blobspace, or sbspace that you want to mirror.	The chunk must be an existing unbuffered device or buffered file. When you specify a path name, you can use either a full path name or a relative path name. However, if you use a relative path name, it must be relative to the directory that was the current directory when you initialized the database server. For path name syntax, see your operating-system documentation.
-y	Causes the database server to automatically respond yes to all prompts	None.
blobspace	Names the blobspace that you want to mirror	Syntax must conform to the Identifier segment; see <i>IBM Informix Guide to SQL: Syntax</i> . For more information, see the chapter on using mirroring in the <i>IBM Informix Administrator's Guide</i> .
dbspace	Names the dbspace that you want to mirror	Syntax must conform to the Identifier segment; see <i>IBM Informix Guide to SQL: Syntax</i> . For background information, see the chapter on using mirroring in the <i>IBM Informix Administrator's Guide</i> .

Element	Purpose	Key considerations
<i>sbspace</i>	Names the sbspace that you want to mirror	Syntax must conform to the Identifier segment; see <i>IBM Informix Guide to SQL: Syntax</i> . For background information, see the chapter on using mirroring in the <i>IBM Informix Administrator's Guide</i> .

Related reference:

“add mirror argument: Add a mirror chunk (SQL administration API)” on page 22-18

“start mirroring argument: Starts storage space mirroring (SQL administration API)” on page 22-118

Using a File to Specify Chunk-Location Information with the -f Option

You can create a file that contains the chunk-location information. Then, when you execute **onspaces**, use the **-f** option to indicate to the database server that this information is in a file whose name you specify in *filename*.

The contents of the file should conform to the following format, with options separated by spaces and each set of primary and mirror chunks on separate lines:

primary_chunk_path offset mirror_chunk_path offset

If the dbspace that you are mirroring contains multiple chunks, you must specify a mirror chunk for each of the primary chunks in the dbspace that you want to mirror. For an example that enables mirroring for a multichunk dbspace, see starting mirroring for unmirrored dbspaces with **onspaces** in the chapter on using mirroring in the *IBM Informix Administrator's Guide*.

onspaces -r: Stop mirroring

Use the **onspaces -r** option to end mirroring for a dbspace, blobspace, or sbspace.

Syntax:

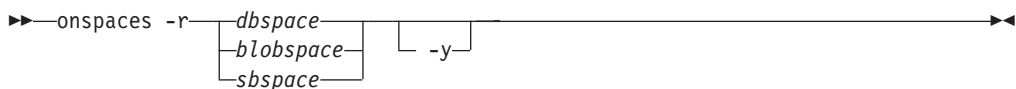

This command has an equivalent SQL administration API function.

Element	Purpose	Key considerations
-r	Indicates to the database server that mirroring should be ended for an existing dbspace, blobspace, or sbspace	For background information, see the chapter on using mirroring in the <i>IBM Informix Administrator's Guide</i> .
-y	Causes the database server to respond yes to all prompts automatically	None.
<i>blobspace</i>	Names the blobspace for which you want to end mirroring.	Syntax must conform to the Identifier segment; see the <i>IBM Informix Guide to SQL: Syntax</i> . For more information, see the chapter on using mirroring in the <i>IBM Informix Administrator's Guide</i> .

Element	Purpose	Key considerations
<i>dbspace</i>	Names the dbspace for which you want to end mirroring.	Syntax must conform to the Identifier segment; see the <i>IBM Informix Guide to SQL: Syntax</i> . For more information, see the chapter on using mirroring in the <i>IBM Informix Administrator's Guide</i> .
<i>sbspace</i>	Names the sbspace for which you want to end mirroring	Syntax must conform to the Identifier segment; see the <i>IBM Informix Guide to SQL: Syntax</i> . For background information, see the chapter on using mirroring in the <i>IBM Informix Administrator's Guide</i> .

Related reference:

“stop mirroring argument: Stops storage space mirroring (SQL administration API)” on page 22-119

onspaces -ren: Rename a dbspace, blobspace, sbspace, or extspace

Use the **onspaces -ren** option to rename a dbspace, blobspace, sbspace, or extspace.

Syntax:

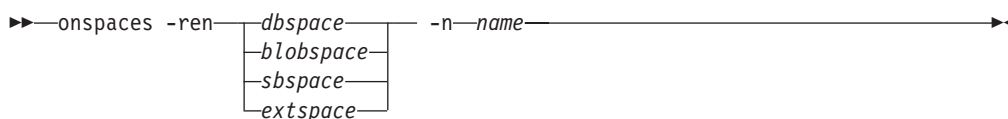

This command has an equivalent SQL administration API function.

Element	Purpose	Key considerations
-ren	Causes the database server to rename the specified blobspace, dbspace, extspace, or sbspace	Restrictions: You can rename a blobspace, dbspace, extspace, or sbspace when the database server is in quiescent mode. For more information, see the chapter on managing disk space in the <i>IBM Informix Administrator's Guide</i> .
-n name	Specifies the new name for the blobspace, dbspace, extspace, or sbspace	Restrictions: The blobspace, dbspace, external space, or sbspace name must be unique and cannot exceed 128 bytes. It must begin with a letter or underscore and must contain only letters, numbers, underscores, or the \$ character. For more information, see the chapter on managing disk space in the <i>IBM Informix Administrator's Guide</i> . The syntax must conform to the Identifier segment. For more information, see the <i>IBM Informix Guide to SQL: Syntax</i> .
<i>blobspace</i>	Names the blobspace to be renamed	Syntax must conform to the Identifier segment; see the <i>IBM Informix Guide to SQL: Syntax</i> . For more information, see renaming spaces, in the chapter on managing disk space in the <i>IBM Informix Administrator's Guide</i> .

Element	Purpose	Key considerations
<i>dbspace</i>	Names the dbspace to be renamed	<p>Restrictions: You cannot rename a critical dbspace, such as the root dbspace or a dbspace that contains physical logs.</p> <p>Additional Information: If you rename dbspaces that are included in the DATASKIP list, update the DATASKIP configuration parameter with the new names using the onspaces -f command.</p> <p>Syntax must conform to the Identifier segment; see the <i>IBM Informix Guide to SQL: Syntax</i>. For more information, see renaming spaces, in the chapter on managing disk space in the <i>IBM Informix Administrator's Guide</i>.</p>
<i>extspace</i>	Names the extspace to be renamed	<p>Syntax must conform to the Identifier segment; see the <i>IBM Informix Guide to SQL: Syntax</i>. For more information, see renaming spaces, in the chapter on managing disk space in the <i>IBM Informix Administrator's Guide</i>.</p>
<i>sbspace</i>	Names the sbspace to be renamed	<p>Syntax must conform to the Identifier segment; see the <i>IBM Informix Guide to SQL: Syntax</i>. For more information, see renaming spaces, in the chapter on managing disk space in the <i>IBM Informix Administrator's Guide</i>.</p>

Related reference:

“rename space argument: Rename a storage space (SQL administration API)” on page 22-99

Renaming a dbspace, blobspace, sbspace, or extspace when Enterprise Replication is active

You can rename a space (dbspace, blobspace, sbspace, or extspace) when Enterprise Replication is active.

When you put the database server into quiescent mode to rename the space, Enterprise Replication will be disconnected. You can then rename the space. The servers will resynchronize after you put the database server into online mode.

If you want to rename the same space on another server, you must put that server into quiescent mode and rename the space separately. No enforced relationship is propagated between renamed spaces on different ER servers; the same tables can be in different spaces.

If the Enterprise Replication server also participates in High-Availability Data Replication (HDR), you can rename the dbspace on the primary server and it will be automatically propagate to the secondary server. (The secondary server cannot participate in Enterprise Replication.)

Performing an Archive after Renaming a Space

After renaming any space (except extspaces or temporary spaces), perform a level-0 archive of the renamed space and the root dbspace. This will ensure that you can restore the spaces to a state including or following the rename dbspace operation. It is also necessary prior to performing any other type of archive.

onspaces -s: Change status of a mirrored chunk

Use the **onspaces -s** option to change the status of a mirrored chunk in a dbspace, a non-primary chunk within a noncritical dbspace, a blobspace, or an sbspace.

Syntax:

```

▶▶ onspaces -s 
dbspace
blobspace
sbspace
 -p pathname -o offset 
-D
-0
 
-y

```

This command has an equivalent SQL administration API function.

Element	Purpose	Key considerations
-D	Indicates that you want to take the chunk down	None.
-o <i>offset</i>	Indicates, in kilobytes, the offset into the disk partition or unbuffered device to reach the chunk	<p>Restrictions: Unsigned integer. The starting offset must be equal to or greater than 0. The starting offset plus the chunk size cannot exceed the maximum chunk size. The offset must be a multiple of the page size.</p> <p>The maximum offset is 4 terabytes.</p> <p>For more information, see allocating raw disk space on UNIX, in the chapter on managing disk space in the <i>IBM Informix Administrator's Guide</i>.</p>
-O	Indicates that you want to restore the chunk and bring it online	None.
-p <i>pathname</i>	Indicates the disk partition or unbuffered device of the chunk	<p>The chunk can be an unbuffered device or a buffered file. When you specify a path name, you can use either a full path name or a relative path name. However, if you use a relative path name, it must be relative to the directory that was the current directory when you initialized the database server.</p> <p>For path name syntax, see your operating-system documentation.</p>
-s	Indicates that you want to change the status of a chunk	<p>Restrictions: You can only change the status of a chunk in a mirrored pair or a non-primary chunk within a noncritical dbspace.</p> <p>For more information, see changing the mirror status in the <i>IBM Informix Administrator's Guide</i>.</p>
-y	Causes the database server to respond yes to all prompts automatically	None.
<i>blobspace</i>	Names the blobspace whose status you want to change	Syntax must conform to the Identifier segment; see the <i>IBM Informix Guide to SQL: Syntax</i> . For more information, see changing the mirror status in the <i>IBM Informix Administrator's Guide</i> .
<i>dbspace</i>	Names the dbspace whose status you want to change	Syntax must conform to the Identifier segment; see the <i>IBM Informix Guide to SQL: Syntax</i> . For more information, see changing the mirror status in the <i>IBM Informix Administrator's Guide</i> .
<i>sbspace</i>	Names the sbspace whose status you want to change	Syntax must conform to the Identifier segment; see the <i>IBM Informix Guide to SQL: Syntax</i> . For background information, see changing the mirror status in the <i>IBM Informix Administrator's Guide</i> .

Related reference:

“alter chunk argument: Change chunk status to online or offline (SQL administration API)” on page 22-19

“set chunk argument: Change the status of a chunk (SQL administration API)” on page 22-106

Avoid overwriting a chunk

The chunks associated with each Informix instance are not known to other Informix instances. It is possible to inadvertently create a chunk on a file or device that is allocated as a chunk to another Informix instance, which results in data corruption.

If you attempt to initialize an instance, where the ROOTPATH configuration parameter specifies a file or device that is the root chunk of another instance, the command fails with the following message in the online.log:

```
DISK INITIALIZATION ABORTED: potential instance overwrite detected.
```

To disable this initialization check, set the FULL_DISK_INIT configuration parameter to 1 in your configuration file and try to initialize the instance again. However, this initialization check is restricted to the root chunk. Adding dbspaces or chunks succeeds even when the file or device is allocated to another instance.

Related reference:

“onspaces -a: Add a chunk to a dbspace or blobspace” on page 20-2

“onspaces -a: Add a chunk to an sbspace” on page 20-3

“onspaces -c -b: Create a blobspace” on page 20-5

“onspaces -c -d: Create a dbspace” on page 20-7

“onspaces -c -S: Create an sbspace” on page 20-11

“create blobspace argument: Create a blobspace (SQL administration API)” on page 22-26

“create chunk argument: Create a chunk (SQL administration API)” on page 22-29

“create dbspace argument: Create a dbspace (SQL administration API)” on page 22-32

“create sbspace argument: Create an sbspace (SQL administration API)” on page 22-34

Chapter 21. The onstat utility

The **onstat** utility reads shared-memory structures and provides statistics about the database server at the time that the command executes.

The *system-monitoring interface* also provides information about the database server. For information on the system-monitoring interface, see Chapter 2, “The sysmaster database,” on page 2-1.

You can combine multiple **onstat** option flags in a single command. The contents of shared memory might change as the **onstat** output displays. The **onstat** utility does not place any locks on shared memory, so running the utility does not affect performance.

These topics show you how to use the following **onstat** options:

- “**onstat -** command: Print output header” on page 21-23
- “**onstat -** command: Print onstat options and functions” on page 21-24
- “Running **onstat** Commands on a Shared Memory Dump File” on page 21-24
- “**onstat -a** command: Print overall status of the database server” on page 21-25
- “**onstat -b** command: Print buffer information for buffers in use” on page 21-25
- “**onstat -B** command: Prints information about used buffers” on page 21-26
- “**onstat -c** command: Print ONCONFIG file contents” on page 21-28
- “**onstat -C** command: Print B-tree scanner information” on page 21-29
- “**onstat -d** command: Print chunk information” on page 21-34
- “**onstat -D** command: Print page-read and page-write information” on page 21-39
- “**onstat -f** command: Print dbspace information affected by dataskip” on page 21-40
- “**onstat -F** command: Print counts” on page 21-40
- “**onstat -g** monitoring options” on page 21-42
- “**onstat -G** command: Print TP/XA transaction information” on page 21-187
- “**onstat -h** command: Print buffer header hash chain information” on page 21-188
- “**onstat -i** command: Initiate interactive mode” on page 21-189
- “**onstat -j** command: Provide onpload status information” on page 21-190
- “**onstat -k** command: Print active lock information” on page 21-192
- “**onstat -l** command: Print physical and logical log information” on page 21-193
- “**onstat -L** command: Print the number of free locks” on page 21-196
- “**onstat -m** command: Print recent system message log information” on page 21-197
- “**onstat -o** command: Output shared memory contents to a file” on page 21-198
- “**onstat -O** command: Print optical subsystem information” on page 21-198
- “**onstat -p** command: Print profile counts” on page 21-200
- “**onstat -P** command: Print partition information” on page 21-203
- “**onstat -r** command: Repeatedly print selected statistics” on page 21-204

- “**onstat -R** command: Print LRU, FLRU, and MLRU queue information” on page 21-207
- “**onstat -s** command: Print latch information” on page 21-209
- “**onstat -t** and **onstat -T** commands: Print tblspace information” on page 21-211
- “**onstat -u** command: Print user activity profile” on page 21-212
- “**onstat -x** command: Print database server transaction information” on page 21-215
- “**onstat -X** command: Print thread information” on page 21-217
- “**onstat -z** command: Clear statistics” on page 21-219

onstat Portal: onstat Utility Commands Sorted by Functional Category

The information in this section lists **onstat** commands sorted by functional category.

Each category represents a different IBM Informix feature for which **onstat** commands are useful for providing troubleshooting and performance enhancement information. Commands that appear in **bold** typeface are especially useful for providing troubleshooting information. Certain **onstat** commands are specific to one category, while others provide more general information and are listed in more than one category.

Category List

To use this section, you first determine the appropriate category from the following list, then follow the link to the **onstat** options for that category.

- “onstat Utility Archive Information Options” on page 21-3
- “onstat Utility Cache Information Options” on page 21-3
- “onstat Utility Debugging Options” on page 21-4
- “onstat Utility Enterprise Replication Options” on page 21-5
- “onstat Utility High-Availability Replication Options” on page 21-6
- “onstat Utility I/O Options” on page 21-7
- “onstat Utility Informix Warehouse Accelerator Options” on page 21-8
- “onstat Utility Locks and Latches Options” on page 21-8
- “onstat Utility Logs Options” on page 21-9
- “onstat Utility Memory Options” on page 21-9
- “onstat Utility Network Options” on page 21-10
- “onstat Utility Performance Checks (First Tier)” on page 21-11
- “onstat Utility Performance Checks (Second Tier)” on page 21-12
- “onstat Utility Table Options” on page 21-13
- “onstat Utility Thread Options” on page 21-14
- “onstat Utility User/Session Options” on page 21-14
- “onstat Utility Virtual Processor Options” on page 21-15
- “onstat Utility Waiting Options” on page 21-16
- “onstat Utility Compression Options” on page 21-16
- “Other Useful onstat Utility Options” on page 21-17

onstat Utility Archive Information Options

Use the following **onstat** options to display information about archives and restores.

Table 21-1. *onstat* Utility Archive Information Options

Commands	Reference
onstat -D	Prints chunk I/O activity. Prints dbspace read/write activity for monitoring restore progress. “ onstat -D command: Print page-read and page-write information” on page 21-39
onstat -g arc	Prints the last committed and any ongoing backups for each dbspace. “ onstat -g arc command: Print archive status” on page 21-52

onstat Utility Cache Information Options

Use the following **onstat** options to display information about caches and cached data, including buffer pools.

Table 21-2. *onstat* Utility Cache Information Options

Commands	Reference
onstat -b	Prints buffer pages in use. “ onstat -b command: Print buffer information for buffers in use” on page 21-25
onstat -B	Prints information about used buffers. “ onstat -B command: Prints information about used buffers” on page 21-26
onstat -F	Prints state of buffer queue cleaners and I/O. “ onstat -F command: Print counts” on page 21-40
onstat -g dic	Prints data dictionary cache, containing system catalog data for tables. Prints one line of information for each table cached in the shared-memory dictionary. For more information, see your <i>IBM Informix Performance Guide</i> . For sample output, see “ onstat -g dic command: Print table information” on page 21-76.
onstat -g dsc	Prints table distribution statistics for the optimizer. “ onstat -g dsc command: Print distribution cache information” on page 21-83.
onstat -g prc	Prints the stored procedure (SPL) routine cache. Prints information about SPL routine cache. “ onstat -g prc command: Print sessions using UDR or SPL routine” on page 21-134.

Table 21-2. *onstat* Utility Cache Information Options (continued)

Commands	Reference
onstat -g ssc	Prints the number of times that the database server reads the SQL statement in the cache. Displays the same output as onstat -g cac . For more information, see improving query performance in the <i>IBM Informix Performance Guide</i> . “ onstat -g ssc command: Print SQL statement occurrences” on page 21-174.
onstat -g vpcache	Prints CPU virtual processor memory cache. “ onstat -g vpcache command: Print CPU VP memory block cache statistics” on page 21-182
onstat -h	Prints buffer hash chain information. “ onstat -h command: Print buffer header hash chain information” on page 21-188
onstat -O	Prints optical subsystem memory cache and staging-area (disk cache) blob space for TEXT or BYTE data. “ onstat -O command: Print optical subsystem information” on page 21-198
onstat -p	Prints global (server) information regarding the effectiveness of buffer pool caching. “ onstat -p command: Print profile counts” on page 21-200
onstat -X	Prints threads waiting for buffers. “ onstat -X command: Print thread information” on page 21-217

onstat Utility Debugging Options

Use the following **onstat** options to display information that is useful for debugging problems with the server.

Table 21-3. *onstat* Utility Debugging Options

Commands	Reference
onstat -g dmp	Prints raw memory at a given address for a number of given bytes. “ onstat -g dmp command: Print raw memory” on page 21-80
onstat -g src	Searches for patterns in shared memory. Note that memory is byte-swapped on Intel platforms. “ onstat -g src command: Patterns in shared memory” on page 21-173
onstat -o	Prints shared memory contents to a file. “ onstat -o command: Output shared memory contents to a file” on page 21-198.

onstat Utility Enterprise Replication Options

Use the following **onstat** options to track Enterprise Replication statistics and to provide troubleshooting information. For additional information about Enterprise Replications see the **cdr view** and **cdr view profile** commands described in the *IBM Informix Enterprise Replication Guide*.

Table 21-4. onstat Utility Enterprise Replication Options

Commands	Reference
onstat -g cat	Prints information from the Enterprise Replication global catalog. The global catalog contains a summary of information about the defined servers, replicates, and replicate sets on each of the servers within the enterprise. “ onstat -g cat command: Print ER global catalog information” on page 21-57.
onstat -g cdr	Prints the settings of Enterprise Replication configuration parameters and environment variables. “ onstat -g cdr config command: Print ER settings” on page 21-59.
onstat -g cdr config	Prints Enterprise Replication configuration parameters and environment variables. “ onstat -g cdr config command: Print ER settings” on page 21-59
onstat -g ddr	Prints status of Enterprise Replication components that read and process log records. “ onstat -g ddr command: Print ER database log reader status” on page 21-74
onstat -g dss	Prints activity of individual data sync (transaction processing) threads. “ onstat -g dss command: Print ER environment data” on page 21-84
onstat -g dtc	Prints delete table cleaner activity. Deleted or updated rows placed in the delete table are purged at intervals. “ onstat -g dtc command: Print delete table cleaner statistics” on page 21-85
onstat -g grp	Prints Enterprise Replication grouper statistics. The grouper evaluates the log records, rebuilds the individual log records into the original transaction, packages the transaction, and queues the transaction for transmission. “ onstat -g grp command: Print ER grouper statistics” on page 21-91
onstat -g nif	Prints network interface statistics. Shows the state of the network interface, servers, and data transfer among servers. “ onstat -g nif command: Print statistics about the network interface” on page 21-120
onstat -g que	Prints statistics for the high-level queue interface (which is common to all of the queues of the Enterprise Replication Queue Manager). “ onstat -g que command: Prints ER queue statistics” on page 21-140

Table 21-4. *onstat* Utility Enterprise Replication Options (continued)

Commands	Reference
onstat -g rcv	Prints receive manager statistics. “ onstat -g rcv command: Print ER receive manager statistics” on page 21-144
onstat -g rep	Prints events that are in the queue for the schedule manager. “ onstat -g rep command: Print ER schedule manager events” on page 21-148
onstat -g rqm	Prints statistics and contents of the low-level queues (send queue, receive queue, ack send queue, sync send queue, and control send queue) managed by the Reliable Queue Manager (RQM). “ onstat -g rqm command: Print low-level queue statistics” on page 21-148
onstat -g sync	Prints synchronization status. “ onstat -g sync command: Print ER synchronization status” on page 21-179

onstat Utility High-Availability Replication Options

Use the following **onstat** options to monitor high-availability cluster environments and the Connection Manager.

Table 21-5. *onstat* Utility High-Availability Replication Options

Commands	Reference
onstat -g cluster	Prints high-availability cluster information. “ onstat -g cluster command: Print high-availability cluster information” on page 21-65
onstat -g cmsm	Prints Connection Manager information. “ onstat -g cmsm command: Print Connection Manager information” on page 21-69
onstat -g dri	Prints data-replication information. See <i>Monitoring High-Availability Data-Replication status</i> in the <i>IBM Informix Administrator's Guide</i> . “ onstat -g dri command: Print high-availability data replication information” on page 21-81.
onstat -g ipl	Prints index page logging status. “ onstat -g ipl command: Print index page logging status information” on page 21-107
onstat -g laq	Prints information about queues on the secondary server. “ onstat -g laq command: Print secondary server queues” on page 21-109
onstat -g proxy	Prints proxy distributors for high-availability. “ onstat -g proxy command: Print proxy distributor information” on page 21-135

Table 21-5. *onstat* Utility High-Availability Replication Options (continued)

Commands	Reference
onstat -g rss	Prints remote stand-alone server (RSS) information. “ onstat -g rss command: Print RS secondary server information” on page 21-151
onstat -g sds	Prints shared disk secondary (SDS) server information. “ onstat -g sds command: Print SD secondary server information” on page 21-157
onstat -g smx	Prints Server Multiplexer Group (SMX) connections in high-availability environments. Prints data transfer statistics and encryption status. “ onstat -g smx command: Print multiplexer group information” on page 21-169

onstat Utility I/O Options

Use the following **onstat** options to track input and output (read and write) activity.

Table 21-6. *onstat* Utility I/O Options

Commands	Reference
onstat -D	Prints chunk I/O activity. “ onstat -D command: Print page-read and page-write information” on page 21-39
onstat -g cpu	Prints runtime statistics for each thread. “ onstat -g cpu : Print runtime statistics” on page 21-71
onstat -g ioa	Prints combined information from onstat -g ioq (queues), onstat -g iov (virtual processors), and onstat -g iob (big buffer). “ onstat -g ioa command: Print combined onstat -g information” on page 21-102
onstat -g iob	Prints the big buffer usage summary. “ onstat -g iob command: Print big buffer use summary” on page 21-103
onstat -g iof	Prints I/O statistics by file or chunk. This option is similar to the onstat -D option, but also displays information about non-chunk, temporary, and sort-work files. “ onstat -g iof command: Print asynchronous I/O statistics” on page 21-104
onstat -g iog	Prints AIO global information. “ onstat -g iog command: Print AIO global information” on page 21-105
onstat -g ioq	Prints queue read/write statistics and queue length. “ onstat -g ioq command: Print I/O queue information” on page 21-105. Also see the <i>IBM Informix Performance Guide</i> .

Table 21-6. *onstat* Utility I/O Options (continued)

Commands	Reference
onstat -g iov	Prints asynchronous I/O statistics by virtual processor. “ onstat -g iov command: Print AIO VP statistics” on page 21-107
onstat -p	Prints global disk activity including sequential scans. “ onstat -p command: Print profile counts” on page 21-200

onstat Utility Informix Warehouse Accelerator Options

Use the following **onstat** options to display information exchanged between the database server and the Informix Warehouse Accelerator.

Table 21-7. *onstat* Utility Informix Warehouse Accelerator options

Commands	Reference
onstat -g aqt	Prints information about the data marts and the associated accelerated query tables (AQTs). “ onstat -g aqt command: Print data mart and accelerated query table information” on page 21-49.

onstat Utility Locks and Latches Options

Use the following **onstat** options to display information about locks.

Table 21-8. *onstat* Utility Locks and Latches Options

Commands	Reference
onstat -k	Prints information about active locks. “ onstat -k command: Print active lock information” on page 21-192
onstat -L	Prints the number of locks on a lock free list. “ onstat -L command: Print the number of free locks” on page 21-196
onstat -p	Prints global statistics on lock requests, lock waits, and latch waits. “ onstat -p command: Print profile counts” on page 21-200
onstat -s	Prints latch (mutex) information. “ onstat -s command: Print latch information” on page 21-209

onstat Utility Logs Options

Use the following **onstat** options to monitor logical and physical logs.

Table 21-9. *onstat* Utility Logs Options

Commands	Reference
onstat -g ipl	Prints index page logging information in high-availability environments. “ onstat -g ipl command: Print index page logging status information” on page 21-107
onstat -l	Prints status of physical and logical logs, and log buffering. “ onstat -l command: Print physical and logical log information” on page 21-193

onstat Utility Memory Options

Use the following **onstat** options to monitor the various aspects of server memory allocation and use.

Table 21-10. *onstat* Utility Memory Options

Commands	Reference
onstat -g afr	Prints allocated memory fragments for a specified session or shared-memory pool. To obtain the pool name, see the onstat -g mem option. “ onstat -g afr command: Print allocated memory fragments” on page 21-48
onstat -g ffr (<i>pool name session ID</i>)	Prints free fragments for a session or shared memory pool. “ onstat -g ffr command: Print free fragments” on page 21-88
onstat -g lmm	Prints information about automatic low memory management settings and recent activity: “ onstat -g lmm command: Print low memory management information” on page 21-111
onstat -g mem	Prints session or pool virtual shared memory statistics. “ onstat -g mem command: Print pool memory statistics” on page 21-114
onstat -g mgm	Prints Memory Grant Manager (parallel and sort operations) resource information. “ onstat -g mgm command: Print MGM resource information” on page 21-116. Also see the <i>IBM Informix Performance Guide</i> .
onstat -g nbm	Prints block map for non-resident segments. “ onstat -g nbm command: Print a block bit map” on page 21-119
onstat -g rbm	Prints block map for resident segment. “ onstat -g rbm command: Print a block map of shared memory” on page 21-143
onstat -g seg	Prints memory segment statistics. “ onstat -g seg command: Print shared memory segment statistics” on page 21-161. Also see the <i>IBM Informix Administrator’s Guide</i> .

Table 21-10. *onstat* Utility Memory Options (continued)

Commands	Reference
onstat -g ses	Prints session information, including memory breakdown. For detailed information, use: onstat -g ses session_id “ onstat -g ses command: Print session-related information” on page 21-162 Also see the <i>IBM Informix Performance Guide</i>
onstat -g stm	Prints SQL statement memory use. “ onstat -g stm command: Print SQL statement memory usage” on page 21-176
onstat -g stq	Prints stream queue buffers. “ onstat -g stq command: Print queue information” on page 21-177
onstat -g ufr	Prints memory pool fragments for a session or shared memory pool in use. “ onstat -g ufr command: Print memory pool fragments” on page 21-181
onstat -R	Prints buffer pool queues and their status. “ onstat -R command: Print LRU, FLRU, and MLRU queue information” on page 21-207

onstat Utility Network Options

Use the following **onstat** options to monitor shared memory and network connection services.

Table 21-11. *onstat* Utility Network Options

Commands	Reference
onstat -g imc	Prints information about Informix MaxConnect instances that are connected to the database server. If Informix MaxConnect is not connected to the database server, this command displays <i>No MaxConnect servers are connected.</i>
onstat -g nsc	Prints shared-memory status by <i>client id</i> . If <i>client id</i> is omitted, all client status areas are displayed. This command prints the same status data as the nss command. “ onstat -g nsc command: Print current shared memory connection information” on page 21-121
onstat -g nsd	Prints network shared-memory data for poll threads. “ onstat -g nsd command: Print poll threads shared-memory data” on page 21-124
onstat -g nss	Prints network shared-memory status by <i>session id</i> . If <i>session id</i> is omitted, all session status areas are displayed. This command prints the same status data as the onstat -g nsc command. “ onstat -g nss command: Print shared memory network connections status” on page 21-124

Table 21-11. *onstat* Utility Network Options (continued)

Commands	Reference
onstat -g nta	Prints combined network statistics from onstat -g ntd , onstat -g ntm , onstat -g ntt , and onstat -g ntu . If Informix MaxConnect is installed, this command prints statistics that you can use to tune Informix MaxConnect performance.
onstat -g ntd	Prints network statistics by service. “ onstat -g ntd command: Print network statistics” on page 21-125
onstat -g ntm	Prints network mail statistics. “ onstat -g ntm command: Print network mail statistics” on page 21-126
onstat -g ntt	Prints network user times. “ onstat -g ntt command: Print network user times” on page 21-126
onstat -g ntu	Prints network user statistics. “ onstat -g ntu command: Print network user statistics” on page 21-127

onstat Utility Performance Checks (First Tier)

Use the following **onstat** options to monitor performance and to check for performance impediments. Use the second-tier **onstat** options (and other **onstat** commands) to further narrow the problem.

Table 21-12. *onstat* Utility Performance Checks (First Tier)

Commands	Reference
onstat -c	Prints server configuration. “ onstat -c command: Print ONCONFIG file contents” on page 21-28
onstat -D	Prints chunk I/O. “ onstat -D command: Print page-read and page-write information” on page 21-39
onstat -g ath	Prints status and statistics for all threads. The sqlexec thread is a client session thread. The rstcb value corresponds to the user field of the onstat -u command. “ onstat -g ath command: Print information about all threads” on page 21-54. For information about using onstat -g ath to print Enterprise Replication threads, see the <i>IBM Informix Enterprise Replication Guide</i> .
onstat -g ckp	Prints checkpoint history and display configuration recommendations. “ onstat -g ckp command: Print checkpoint history and configuration recommendations” on page 21-61
onstat -g cpu	Prints runtime statistics for each thread. “ onstat -g cpu : Print runtime statistics” on page 21-71

Table 21-12. *onstat* Utility Performance Checks (First Tier) (continued)

Commands	Reference
onstat -g ioq	Prints pending I/O operations for the <i>queue name</i> . “ onstat -g ioq command: Print I/O queue information” on page 21-105
onstat -p	Prints global server performance profile. “ onstat -p command: Print profile counts” on page 21-200
onstat -u	Prints status and statistics for user threads. If a thread is waiting for a resource, this command identifies the type (flags field) and address (wait field) of the resource. “ onstat -u command: Print user activity profile” on page 21-212

onstat Utility Performance Checks (Second Tier)

Use the following **onstat** options to identify performance impediments.

Table 21-13. *onstat* Utility Performance Checks (Second Tier)

Commands	Reference
onstat -b	Prints active buffers. “ onstat -b command: Print buffer information for buffers in use” on page 21-25
onstat -g act	Prints active threads. “ onstat -g act command: Print active threads” on page 21-48
onstat -g glo	Prints virtual processors and their operating system processes (oninit processes). Prints virtual processor CPU use. On Windows, the virtual processors are operating system threads, and the values in the pid field are thread IDs. “ onstat -g glo command: Print global multithreading information” on page 21-89
onstat -g mgm	Prints Memory Grant Manager resource information. “ onstat -g mgm command: Print MGM resource information” on page 21-116
onstat -g rah	Prints read-ahead request information “ onstat -g rah command: Print read-ahead request statistics” on page 21-142
onstat -g rea	Prints threads in the ready queue waiting for CPU resources. “ onstat -g rea command: Print ready threads” on page 21-147
onstat -g seg	Prints shared-memory-segment statistics. This option shows the number and size of shared-memory segments allocated to the database server. “ onstat -g seg command: Print shared memory segment statistics” on page 21-161.

Table 21-13. *onstat* Utility Performance Checks (Second Tier) (continued)

Commands	Reference
onstat -g wai	Prints waiting threads; all threads waiting for mutex or condition, or yielding. “ onstat -g wai command: Print wait queue thread list” on page 21-184
onstat -k	Prints active locks. “ onstat -k command: Print active lock information” on page 21-192

onstat Utility Table Options

Use the following **onstat** options to display information about table status and table statistics.

Table 21-14. *onstat* Utility Table Options

Commands	Reference
onstat -g buf	Prints buffer pool profile information. “ onstat -g buf command: Print buffer pool profile information” on page 21-55
onstat -g lap	Prints information about the status of currently active light appends (writes bypassing the buffer pool). “ onstat -g lap command: Print light appends status information” on page 21-109
onstat -g opn	Prints open partitions (tables). “ onstat -g opn command: Print open partitions” on page 21-127
onstat -g ppf	Prints partition profile (activity data) for the specified partition number or prints profiles for all partitions. “ onstat -g ppf command: Print partition profiles” on page 21-132
onstat -g scn	Prints information about the progress of a scan, based on rows scanned on compressed tables, tables with rows that are larger than a page, and tables with VARCHAR, LVARCHAR, and NVARCHAR data, and identifies whether a scan is a light or bufferpool scan. “ onstat -g scn command: Print scan information” on page 21-155
onstat -P	Prints table and B-tree pages in the buffer pool, listed by partition (table). “ onstat -P command: Print partition information” on page 21-203
onstat -t onstat -T	Prints basic tblspace (partition) information for active (t) or all (T) tblspaces. “ onstat -t and onstat -T commands: Print tblspace information” on page 21-211

onstat Utility Thread Options

Use the following **onstat** options to display the status and activity of threads.

Table 21-15. *onstat* Utility Thread Options

Commands	Reference
onstat -g act	Prints active threads. This output is included in onstat -g ath output. “ onstat -g act command: Print active threads” on page 21-48
onstat -g ath	Prints all threads. “ onstat -g ath command: Print information about all threads” on page 21-54. For information about using onstat -g ath to print Enterprise Replication threads, see the <i>IBM Informix Enterprise Replication Guide</i> .
onstat -g cpu	Prints runtime statistics for each thread. “ onstat -g cpu : Print runtime statistics” on page 21-71
onstat -g rea	Prints ready threads (threads waiting for CPU resource). This output is included in the onstat -g ath output. “ onstat -g rea command: Print ready threads” on page 21-147.
onstat -g sle	Prints information about threads sleeping for a specified time. Does not include threads that are sleeping forever. “ onstat -g sle command: Print all sleeping threads” on page 21-167
onstat -g stk	Prints the stack of a specified thread or prints stacks for all threads. “ onstat -g stk command: Print thread stack” on page 21-176
onstat -g sts	Prints maximum and current stack use per thread. “ onstat -g sts command: Print stack usage for each thread” on page 21-177
onstat -g tpf	Prints thread activity statistics. “ onstat -g tpf command: Print thread profiles” on page 21-180
onstat -g wai	Prints waiting (idle, sleeping, and waiting) threads. Included in onstat -g ath output. “ onstat -g wai command: Print wait queue thread list” on page 21-184
onstat -g wst	Prints wait statistics for threads. “ onstat -g wst command: Print wait statistics for threads” on page 21-185

onstat Utility User/Session Options

Use the following **onstat** options to display information about the user environment and active sessions.

Table 21-16. *onstat* Utility User/Session Options

Commands	Reference
onstat -g env	Prints the values of environment variables the database server is currently using. “ onstat -g env command: Print environment variable values” on page 21-86
onstat -g his	Prints SQL tracing information. “ onstat -g his command: Print SQL trace information” on page 21-97
onstat -g pqs	Prints operators used in currently running SQL queries. “ onstat -g pqs command: Print operators for all SQL queries” on page 21-133
onstat -g ses	Prints summary information for all active sessions or detailed information for individual sessions. “ onstat -g ses command: Print session-related information” on page 21-162
onstat -g sql	Prints SQL information for all active sessions or detailed SQL information for individual sessions. “ onstat -g sql command: Print SQL-related session information” on page 21-172
onstat -G	Prints global transactions. “ onstat -G command: Print TP/XA transaction information” on page 21-187
onstat -u	Prints status of user threads and their global read/write statistics. “ onstat -u command: Print user activity profile” on page 21-212
onstat -x	Prints information about transactions. “ onstat -x command: Print database server transaction information” on page 21-215

onstat Utility Virtual Processor Options

Use the following **onstat** options to display information and statistics for virtual processors.

Table 21-17. *onstat* Utility Virtual Processor Options

Commands	Reference
onstat -g glo	Prints global multithreading information and global statistics for virtual processor classes and individual virtual processors. On Windows, the virtual processors are operating system threads, and the values in the pid field are thread IDs. “ onstat -g glo command: Print global multithreading information” on page 21-89

Table 21-17. *onstat* Utility Virtual Processor Options (continued)

Commands	Reference
onstat -g sch	Prints the number of semaphore operations, spins, and busy waits for each virtual processor. On Windows, the virtual processors are operating system threads, and the values in the pid field are thread IDs. “ onstat -g sch command: Print VP information” on page 21-155

onstat Utility Waiting Options

Use the following **onstat** options to display information about wait conditions for threads.

Table 21-18. *onstat* Utility Waiting Options

Commands	Reference
onstat -g con	Prints IDs of threads waiting for conditions. “ onstat -g ath to print thread information. See “ onstat -g con command: Print condition and thread information” on page 21-71
onstat -g lmx	Prints all locked mutexes. “ onstat -g lmx command: Print all locked mutexes” on page 21-113
onstat -g qst	Prints queue wait statistics for mutex and condition queues. “ onstat -g qst command: Print wait options for mutex and condition queues” on page 21-141
onstat -g rwm	Prints read/write mutexes. “ onstat -g rwm command: Print read and write mutexes” on page 21-154
onstat -g spi	Prints spin locks with long spins and spin lock statistics. “ onstat -g spi command: Print spin locks with long spins” on page 21-171
onstat -g wai	Prints waiting threads; all threads waiting for mutex or condition, or yielding. “ onstat -g wai command: Print wait queue thread list” on page 21-184
onstat -g wmx	Prints all mutexes with waiters. “ onstat -g wmx command: Print all mutexes with waiters” on page 21-184

onstat Utility Compression Options

Table 21-19. *onstat* Utility Compression Options

Commands	Reference
onstat -g dsk	Prints progress of currently running compression operations. “ onstat -g dsk command: Print the progress of the currently running compression operation” on page 21-78

Table 21-19. *onstat* Utility compression Options (continued)

Commands	Reference
onstat -g ppd	Prints partition compression dictionary information. “ onstat -g ppd command: Print partition compression dictionary information” on page 21-131

Other Useful *onstat* Utility Options

Table 21-20. Other Useful *onstat* Utility Options

Commands	Reference
onstat -	Prints onstat header; includes engine version, status (On-Line, Quiescent, and so on), elapsed time since initialization, and memory footprint. “ onstat - command: Print output header” on page 21-23
onstat -	Prints onstat usage options. “ onstat - command: Print onstat options and functions” on page 21-24
onstat options infile	Print onstat output using a shared memory dump (infile) as input. “Running onstat Commands on a Shared Memory Dump File” on page 21-24
onstat -a	Prints collective onstat outputs. “ onstat -a command: Print overall status of the database server” on page 21-25
onstat -c	Prints the server configuration file. “ onstat -c command: Print ONCONFIG file contents” on page 21-28
onstat -C	Prints B-tree index scanner information (shows statistics about index cleaning). “ onstat -C command: Print B-tree scanner information” on page 21-29
onstat -d	Prints chunk information. “ onstat -d command: Print chunk information” on page 21-34
onstat -f	Prints dbspaces configured for dataskip. “ onstat -f command: Print dbspace information affected by dataskip” on page 21-40
onstat -g all	Prints diagnostic information. “ onstat -g all command: Print diagnostic information” on page 21-49
onstat -g dbc	Prints statistics about dbScheduler and dbWorker threads. “ onstat -g dbc command: Print dbScheduler and dbWorker thread statistics” on page 21-73

Table 21-20. Other Useful onstat Utility Options (continued)

Commands	Reference
onstat -g dis	Prints a list of database servers, their status, directory location, configuration information, and host name. “ onstat -g dis command: Print database server information” on page 21-77
onstat -g dll	Prints a list of dynamic libraries that have been loaded. “ onstat -g dll command: Print dynamic link library file list” on page 21-79
onstat -g osi	Prints information about operating system resources and parameters. “ onstat -g osi : Print operating system information” on page 21-129
onstat -g pos	Prints values from \$INFORMIXDIR/etc/.infos.servernum file, which are used by clients such as onmode for shared memory connections to the server. onmode -R rebuilds the \$INFORMIXDIR/etc/.infos.servernum file. “ onstat -g pos command: Print file values” on page 21-130
onstat -g smb	Prints detailed information about sbspaces. “ onstat -g smb command: Print sbspaces information” on page 21-167
onstat -g sym	Prints symbol table information for the oninit utility. “ onstat -g sym command: Print symbol table information for the oninit utility” on page 21-178
onstat -i	Changes onstat mode to interactive. “ onstat -i command: Initiate interactive mode” on page 21-189
onstat -j	Prints information about the status of an onpload job. “ onstat -j command: Provide onpload status information” on page 21-190
onstat -m	Prints message log contents. “ onstat -m command: Print recent system message log information” on page 21-197
onstat -O	Prints Optical subsystem cache information. “ onstat -O command: Print optical subsystem information” on page 21-198
onstat -r	Prints repetitive onstat execution. “ onstat -r command: Repeatedly print selected statistics” on page 21-204
onstat -z	Resets the accumulated statistics to zero. “ onstat -z command: Clear statistics” on page 21-219

Monitor the database server status

To monitor the database server status, view the heading of the **onstat** command.

Whenever the database server is blocked, **onstat** displays the following line after the banner line:

Blocked: *reason*

The variable *reason* can be one or more of the following values.

Reason	Description
ADMINISTRATION	Database is in administration mode
ARCHIVE	Ongoing storage-space backup
ARCHIVE_EBR	Blocked for External Backup and Recovery.
CHG_PLOG	Blocked while physical log is being changed.
CKPT	Checkpoint
CKPT INP	Interval checkpoint in progress
DBS_DROP	Dropping a dbspace
DDR	Discrete data replication
DYNAMIC_LOG	Log file is being added dynamically
DYNAMIC_LOG_FOR_ER	Log file is being added dynamically in ER setup
FREE_LOG	Log file is being freed
HA_CONV_STD	Blocked while High Availability server is being converted to standard server.
HA_FAILOVER	Blocked while High Availability server failover being processed.
HANG_SYSTEM	Database server failure
LAST_LOG_RESERVED4BACKUP	Waiting for last available log to be backed up
LBU	Logs full high-watermark
LOG_DROP	Log file is being dropped
LONGTX	Long transaction
MEDIA_FAILURE	Media failure
OVERRIDE_DOWN_SPACE	Waiting to override down dbspace setting because the ONDBSPACEDOWN onconfig parameter is set to WAIT

In this table, the value CKPT INP does not indicate that the database server is blocked, but that a nonblocking interval checkpoint is in progress while the buffer pool is being flushed. This CKPT INP value appears in the status line of **onstat** output until all pages in the shared-memory buffer pool have been written to disk. For information about setting interval checkpoints to flush the buffer pool, see the “CKPTINTVL configuration parameter” on page 1-40.

onstat Command Syntax

The complete syntax for the **onstat** command, including information about the interactive mode and how to have options to execute repeatedly.

```

▶▶ onstat [-pu]

```

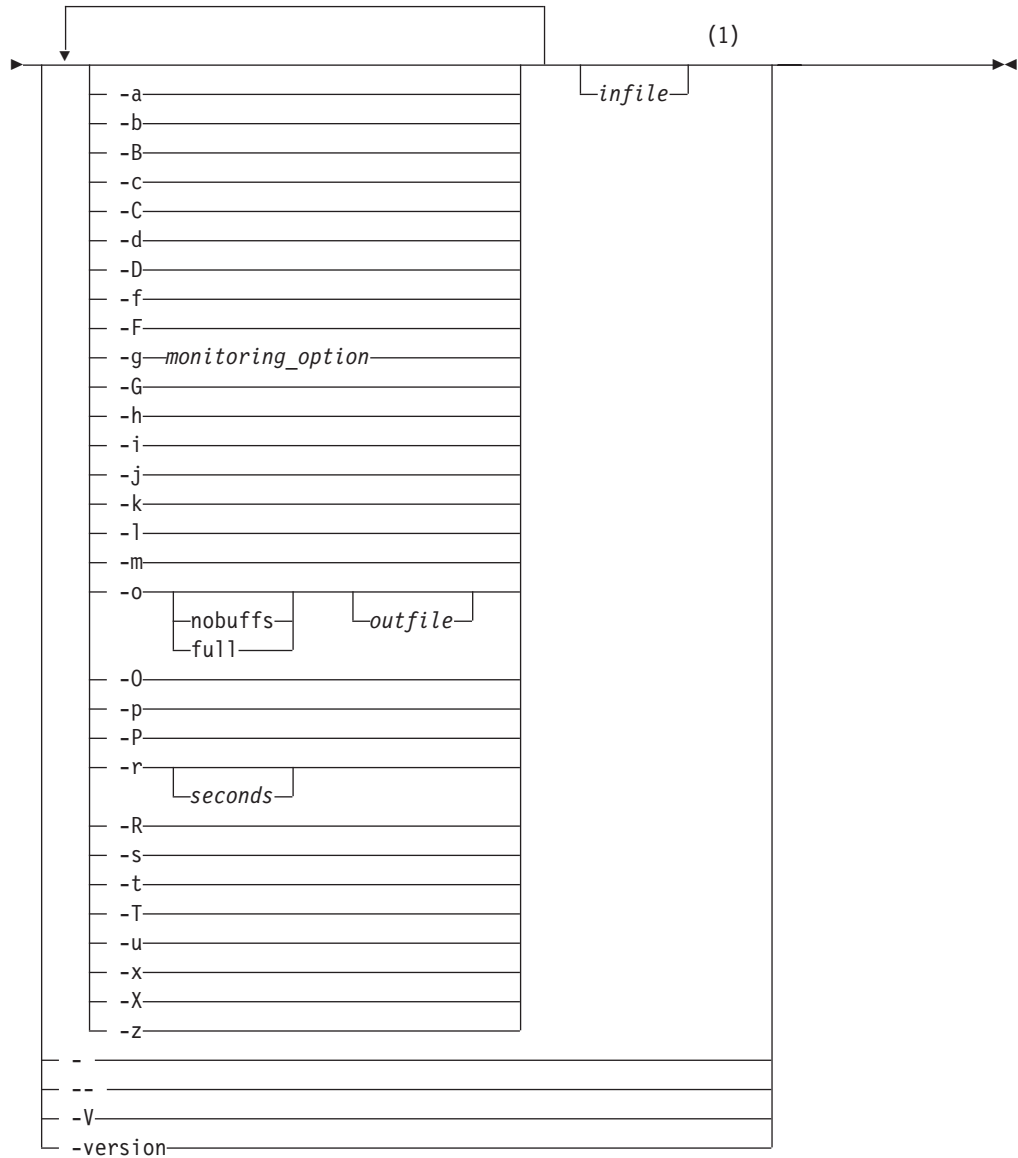

Notes:

- 1 Only one occurrence of each item is allowed. More than one option can be specified on a single **onstat** command invocation.

Element	Purpose	Key Considerations
-	Displays the output header only.	See “ onstat - command: Print output header” on page 21-23.
--	Displays a listing of all onstat options and their functions	See “ onstat - command: Print onstat options and functions” on page 21-24. This option cannot be combined with any other onstat option.
-a	Interpreted as onstat -cuskbtdlp . Displays output in that order.	See “ onstat -a command: Print overall status of the database server” on page 21-25.

Element	Purpose	Key Considerations
-b	Displays information about buffers currently in use, including number of resident pages in the buffer pool	See “ onstat -b command: Print buffer information for buffers in use” on page 21-25.
-B	Obtains information about all database server buffers, not just buffers currently in use.	See “ onstat -B command: Prints information about used buffers” on page 21-26.
-c	Displays the ONCONFIG file: <ul style="list-style-type: none"> • \$INFORMIXDIR/etc/\$ONCONFIG for UNIX • %INFORMIXDIR%\etc\ %ONCONFIG% for Windows 	See “ onstat -c command: Print ONCONFIG file contents” on page 21-28.
-C	Prints B-tree scanner information	See “ onstat -C command: Print B–tree scanner information” on page 21-29.
-d	Displays information for chunks in each storage space	See “ onstat -d command: Print chunk information” on page 21-34.
-D	Displays page-read and page-write information for the first 50 chunks in each dbspace	See “ onstat -D command: Print page-read and page-write information” on page 21-39.
-f	Lists the dbspaces currently affected by the DATASKIP feature	See “ onstat -f command: Print dbspace information affected by dataskip” on page 21-40.
-F	Displays a count for each type of write that flushes pages to disk	See “ onstat -F command: Print counts” on page 21-40.
-g option	Prints monitoring option	See “ onstat -g monitoring options” on page 21-42.
-G	Prints global transaction IDs	See “ onstat -G command: Print TP/XA transaction information” on page 21-187.
-h	Provides information on the buffer header hash chains	See “ onstat -h command: Print buffer header hash chain information” on page 21-188.
-i	Puts the onstat utility into interactive mode	See “ onstat -i command: Initiate interactive mode” on page 21-189.
-j	Prints the interactive status of the active onpload process	See “ onstat -j command: Provide onpload status information” on page 21-190.
-k	Displays information about active locks	See “ onstat -k command: Print active lock information” on page 21-192.
-l	Displays information about physical and logical logs, including page addresses	See “ onstat -l command: Print physical and logical log information” on page 21-193.
-m	Displays the 20 most recent lines of the database server message log	Output from this option lists the full pathname of the message-log file and the 20 file entries. A date-and-time header separates the entries for each day. A time stamp prefaces single entries within each day. The name of the message log is specified as MSGPATH in the ONCONFIG file. See “ onstat -m command: Print recent system message log information” on page 21-197.
-o	Saves a copy of the shared-memory segments to <i>outfile</i>	See “ onstat -o command: Output shared memory contents to a file” on page 21-198.
-O	Displays information about the Optical Subsystem memory cache and staging-area blobospace	See “ onstat -O command: Print optical subsystem information” on page 21-198.

Element	Purpose	Key Considerations
-p	Displays profile counts.	See “ onstat -p command: Print profile counts” on page 21-200.
-P	Displays for all partitions the partition number and the break-up of the buffer-pool pages that belong to the partition	See “ onstat -P command: Print partition information” on page 21-203.
-pu	If you invoke onstat without any options, the command is interpreted as onstat -pu (-p option and -u option). Displays profile counts and prints a profile of user activity	See “ onstat -p command: Print profile counts” on page 21-200 and “ onstat -u command: Print user activity profile” on page 21-212.
-r seconds	Repeats the accompanying onstat options after a wait time specified in <i>seconds</i> between each execution	See “ onstat -r command: Repeatedly print selected statistics” on page 21-204.
-R	Displays detailed information about the LRU queues, FLRU queues, and MLRU queues	See “ onstat -R command: Print LRU, FLRU, and MLRU queue information” on page 21-207.
-s	Displays general latch information	See “ onstat -s command: Print latch information” on page 21-209.
-t	Displays tbspace information, including residency state, for active tbspaces	See “ onstat -t and onstat -T commands: Print tbspace information” on page 21-211.
-T	Displays tbspace information for all tbspaces	See “ onstat -t and onstat -T commands: Print tbspace information” on page 21-211.
-u	Prints a profile of user activity	See “ onstat -u command: Print user activity profile” on page 21-212.
-V	Displays the software version number and the serial number. This option cannot be combined with any other onstat option.	See “Obtaining Utility Version Information” on page 6-1.
-version	Displays the build version, host, OS, number and date, as well as the GLS version. This option cannot be combined with any other onstat option.	See “Obtaining Utility Version Information” on page 6-1.
-x	Displays information about transactions	See “ onstat -x command: Print database server transaction information” on page 21-215.
-X	Obtains precise information about the threads that are sharing and waiting for buffers	See “ onstat -X command: Print thread information” on page 21-217.
-z	Sets the profile counts to 0	See “ onstat -z command: Clear statistics” on page 21-219.
<i>infile</i>	Specifies a source file for the onstat command	This file must include a previously stored shared-memory segment that you created with the onstat -o command. For instructions on how to create the <i>infile</i> with onstat -o , see “ onstat -o command: Output shared memory contents to a file” on page 21-198. For information about running onstat on the source file, see “Running onstat Commands on a Shared Memory Dump File” on page 21-24.

Interactive Execution

To put the **onstat** utility in interactive mode, use the **-i** option. Interactive mode allows you to enter multiple options, one after the other, without exiting the program. For information on using interactive mode, see “**onstat -i** command: Initiate interactive mode” on page 21-189.

Continuous onstat command Execution

Use the **onstat -r** option combined with other **onstat** options to cause the other options to execute repeatedly at a specified interval. For information, see “**onstat -r** command: Repeatedly print selected statistics” on page 21-204.

onstat command: Equivalent to the onstat -pu command

If you invoke **onstat** without any options, the command is interpreted as **onstat -pu** (the **-p** option and the **-u** option).

Syntax:

```
▶▶ onstat —————▶▶
```

onstat - command: Print output header

All **onstat** output includes a header. The **onstat -** command displays only the output header and the value that is returned from this command indicates the database server mode.

Syntax:

```
▶▶ onstat - - —————▶▶
```

The header takes the following form:

```
Version--Mode (Type)--(Checkpnt)--Up Uptime--Sh_mem Kbytes
```

Version

Is the product name and version number

Mode

Is the current operating mode.

(Type)

If the database server uses High-Availability Data Replication, indicates whether the type is primary or secondary

If the database server is not involved in data replication, this field does not appear. If the type is primary, the value P appears. If the type is secondary, the value S appears.

(Checkpnt)

Is a checkpoint flag

If it is set, the header might display two other fields after the mode if the timing is appropriate:

(CKPT REQ)

Indicates that a user thread has requested a checkpoint

(CKPT INP)

Indicates that a checkpoint is in progress. During the checkpoint,

access is limited to read only. The database server cannot write or update data until the checkpoint ends

Uptime

Indicates how long the database server has been running

If the system time is manually changed to the past and the server startup time is later than the current system time, the uptime is not available. In this situation, the header displays the text `Uptime Unavailable`.

Sh_mem

Is the size of database server shared memory, expressed in kilobytes

A sample header for the database server follows:

```
Informix Version  
11.70.UC1--On-Line--Up 15:11:41--9216 Kbytes
```

If the database server is blocked, the **onstat** header output includes an extra line. For information about status codes in that line, see “Monitor the database server status” on page 21-18.

Return codes

When you exit the **onstat** utility, there are several useful codes that are displayed. See “Return codes on exiting the **onstat** utility” on page 21-219.

onstat – command: Print onstat options and functions

Use the **onstat –** command to display a listing of all of the **onstat** options and their functions. You cannot combine this option with any other flag.

Syntax:

```
▶▶ onstat -- _____ ▶▶
```

Running onstat Commands on a Shared Memory Dump File

You can run **onstat** commands against a shared memory dump file. The shared memory dump file can be produced explicitly by using the **onstat -o** command. If the DUMPSHMEM configuration parameter is set to 1 or set to 2, the dump file is created automatically at the time of an assertion failure.

Syntax:

```
▶▶ onstat options infile _____ ▶▶
```

When using the command line, enter the source file as the final argument. The following example prints information about all threads for the shared memory dump contained in the file named `onstat.out`, rather than attempting to attach to the shared memory of a running server.

```
onstat -g ath onstat.out
```

For instructions on how to create the memory dump file with **onstat -o**, see “**onstat -o** command: Output shared memory contents to a file” on page 21-198.

Running onstat Commands on a Shared Memory Dump File Interactively

Use **onstat -i** (interactive mode) to run more than one **onstat** command against a dump file. Interactive mode can save time because the file is read only once. In command-line mode, each command reads the file.

The following example reads the shared memory dump file and enters interactive mode. Other **onstat** commands can be executed against the dump file in the normal interactive fashion.

```
onstat -i source_file
```

For information about interactive mode, see “**onstat -i** command: Initiate interactive mode” on page 21-189.

Running onstat Commands on a Shared Memory Dump File Created Without a Buffer Pool

Certain **onstat** commands have different output when you run them on a dump file created without the buffer pool (created with **onstat -o nobuffs** or with the DUMPSHMEM configuration parameter set to 2):

- If you run **onstat -B** on a dump file created without the buffer pool, the output will display 0 in the memaddr, nslots, and pgflgs columns.
- If you run **onstat -g seg** on a dump file created without the buffer pool, the output will show both the original and nobuffs resident segment size.
- If you run **onstat -P** on a shared-memory dump file that does not have the buffer pool, the output is:

```
Nobuffs dumpfile -- this information is not available
```

onstat -a command: Print overall status of the database server

Use the **onstat -a** command to display information about the status of the database server. This command does not display information about all of the onstat options, only about those onstat options used for initial troubleshooting.

Syntax:

```
▶▶ onstat -a ▶▶
```

onstat -b command: Print buffer information for buffers in use

Use the **onstat -b** option to display information about the buffers that are currently in use, including the total number of resident pages in the buffer pool.

Syntax:

```
▶▶ onstat -b ▶▶
```

The maximum number of buffers available is specified in the **buffers** field in the BUFFERPOOL configuration parameter in the ONCONFIG file.

The **onstat -b** command also provides summary information about the number of modified buffers, the total number of resident pages in the buffer pool, the total number of buffers available, the number of hash buckets available, and the size of the buffer in bytes (the page size).

123 modified, 23 resident, 2000 total, 2048 hash buckets, 2048 buffer size.

For information about displaying information about all buffers, use “**onstat -B** command: Prints information about used buffers.”

Example output

Following is sample output from the **onstat -b** command. For a description of the output, see “**onstat -B** command: Prints information about used buffers.”

```
Buffer pool page size: 4096

address      userthread flgs pagenum memaddr      nslots pgflgs xflgs owner waitlist
70000001097e9e8 0          c07 1:47841 7000000118e0000 10      1      0      0      0
700000010982188 0          807 1:47827 700000011939000 225     90     10     0      0
2011 modified, 50000 total, 65536 hash buckets, 4096 buffer size
```

Figure 21-1. **onstat -b** command output

onstat -B command: Prints information about used buffers

Use the **onstat -B** option to display information about buffers that are not on the free-list.

Syntax:

▶▶—onstat— -B—▶▶

Both **onstat -B** and **onstat -b** display the similar information, except that the **onstat -b** command only displays buffers that are currently being accessed by a user thread. The **onstat -B** command displays information for all the buffers that are not on the free-list.

For information about running the **onstat -B** command on a dump file created without the buffer pool, see “Running **onstat** Commands on a Shared Memory Dump File” on page 21-24.

Example output

```

Buffer pool page size: 4096

address      userthread flgs pagenum memaddr          nslots pgflgs xflgs owner          waitlist
700000010932fe8 0          806 1:40264 700000011150000 5      8b0  0  0          0
700000010933088 0          806 1:40284 700000011151000 5      870  0  0          0
.
.
700000010933e48 0          806 1:44585 700000011167000 113    8890 0  0          0
700000010933ee8 0          806 1:42578 700000011168000 5      802  0  0          0
700000010933f88 0          86  1:44348 700000011169000 39     890  0  ffffffff 0
700000010934028 0          6   1:8     70000001116a000 0      1800 0  0          0
7000000109340c8 0          806 1:246   70000001116b000 5      802  0  0          0
.
.
700000010941c28 0          807 1:46486 7000000112ca000 123    801  0  0          0
700000010941ea8 0          806 1:47101 7000000112ce000 10     801  0  0          0
25 modified, 50000 total, 65536 hash buckets, 4096 buffer size

```

Figure 21-2. `onstat -B` command output

Output description

Buffer pool page size

the size of the buffer pool pages in bytes

address the address of the buffer header in the buffer table

userthread

the address of the most recent user thread to access the buffer table. Many user threads might be reading the same buffer concurrently.

flgs Uses the following flag bits to describe the buffer:

0x01 Modified data

0x02 Data

0x04 LRU

0x08 Error

pagenum

the physical page number on the disk

memaddr

the buffer memory address

nslots the number of slot-table entries in the page

This field indicates the number of rows (or portions of a row) that are stored on the page.

pgflgs Uses the following values, alone or in combination, to describe the page type:

1 Data page

2 Tblspace page

4 Free-list page

8 Chunk free-list page

9 Remainder data page

b Partition resident blobpage

c Blobspace resident blobpage

d	Blob chunk free-list bit page
e	Blob chunk blob map page
10	B-tree node page
20	B-tree root-node page
40	B-tree branch-node page
80	B-tree leaf-node page
100	Logical-log page
200	Last page of logical log
400	Sync page of logical log
800	Physical log
1000	Reserved root page
2000	No physical log required
8000	B-tree leaf with default flags
<i>xflgs</i>	Uses the following flag bits to describe buffer access:
0x10	share lock
0x80	exclusive lock
<i>owner</i>	the user thread that set the xflgs buffer flag
<i>waitlist</i>	the address of the first user thread that is waiting for access to this buffer
	For a complete list of all threads waiting for the buffer, refer to “ onstat -X command: Print thread information” on page 21-217.

onstat -c command: Print ONCONFIG file contents

Use the **onstat -c** command to display the contents of the ONCONFIG file.

Syntax:

```
▶▶ onstat -c ◀◀
```

The database server first checks if you have assigned a value to the environment variable **ONCONFIG**. You can use the **onstat -c** option with the database server in any mode, including offline.

UNIX Only:

On UNIX, if you have set **ONCONFIG**, **onstat -c** displays the contents of the **\$INFORMIXDIR/etc/\$ONCONFIG** file. If not, by default, **onstat -c** displays the contents of **\$INFORMIXDIR/etc/onconfig**.

Windows Only:

On Windows, if you have set **ONCONFIG**, **onstat -c** displays the contents of the **%INFORMIXDIR%\etc\%ONCONFIG%** file. If not, by default, **onstat -c** displays the contents of **%INFORMIXDIR%\etc\onconfig**.

onstat -C command: Print B-tree scanner information

Use the `-C` command to display information about the B-tree scanner subsystem and each B-tree scanner thread.

Syntax:



The following options are available with the `onstat -C` command and can be combined:

- prof* Prints the profile information for the system and each B-tree scanner thread. This is the default option.
- hot* Prints the hot list index key in the order to be cleaned
- part* Prints all partitions with index statistics
- clean* Prints information about all the partitions that were cleaned or need to be cleaned
- range* Prints the savings in pages processed by using index range scanning
- map** Displays the current bitmaps for each index being cleaned by the alice cleaning method
- alice** Displays the efficiency of the alice cleaning method option
- all* Prints all `onstat -C` options

Example output using the `prof` option

```

Btree Cleaner Info
BT scanner profile Information
=====
Active Threads                1
Global Commands              2000000 Building hot list
Number of partition scans    11003
Main Block                   0xc000000003c9dc68
BTC Admin                    0xc0000000024bc208

BTS info      id Prio  Partnum  Key  Cmd
0xc000000003c9dee8  0 High  0x00000000  0  40 Yield N
  Number of leaves pages scanned 77
  Number of leaves with deleted items 6
  Time spent cleaning (sec) 0
  Number of index compresses 0
  Number of deleted items 113
  Number of index range scans 0
  Number of index leaf scans 0
  Number of index alic scans 2

```

Figure 21-3. **onstat -C** command output with the *prof* option

Output description using the *prof* option

- Id* BTSCANNER ID
- Prio* Current priority of BTSCANNER
- Partnum*
The partition number for the index this thread is currently working on
- Cmd* Command this thread is processing currently

Example output using the *hot* option

```

Btree Cleaner Info

Index Hot List
=====
  Current Item      5 List Created      15:29:47
  List Size        4 List expires in   0 sec
  Hit Threshold    500 Range Scan Threshold -1

Partnum  Key      Hits
0x00100191  1      14 *
0x00A00022  1      13 *
0x00100191  2       8 *
0x00100150  2       7 *

```

Figure 21-4. **onstat -C** command output with the *hot* option

Output description using the *hot* option

- Partnum*
The partition number for an index
- Key* Index Key
- Hits* The current value of the Hit counter

- * Indicates that this partition has been cleaned during this hot list duration

Example output using the part option

```

Btree Cleaner Info

Index Statistics
=====
Partnum Key   Positions  Compress  Split
0x00100002 1      146        0         0
0x00100004 1         4         0         0
0x00100004 2        13        0         0
0x00100005 1         1         0         0
0x00100005 2         0         0         0
0x00100006 1         1         0         0
0x00100006 2         0         0         0
0x00100007 2         1         0         0
0x00100008 2         1         0         0
0x0010000a 1         0         0         0
0x0010000e 3         1         0         0
0x00100011 1         1         0         0
0x00100013 2         2         0         0

```

Figure 21-5. **onstat -C** command output with the part option

Output description using the part option

Partnum

The partition number for an index

Key Index Key

Positions

Number of times index has been read

Compress

Number of pages which have been compressed

Split Number of splits that have occurred

C Indicates partition is busy being cleaned

N Index partition no longer eligible for cleaning

Example output using the clean option

```

Btree Cleaner Info

Index Cleaned Statistics
=====
Partnum Key      Dirty Hits  Clean Time  Pg Examined  Items Del  Pages/Sec
0x00100013 2          2           0            0            0           0.00
0x0010008b 3          1           0            0            0           0.00
0x001000c7 1          2           0            0            0           0.00
0x00100150 2          7           0            0            0           0.00
0x0010016f 2          2           0            0            0           0.00
0x00100191 1         14           0            0            0           0.00
0x00100191 2          8           0            0            0           0.00
0x00a00011 2          6           0            0            0           0.00
0x00a00013 1          0           0            24           0           24.00
0x00a00019 1          0           0            470          225         470.00
0x00a00022 1         13           0            0            0           0.00
0x00a00022 2          5           0            0            0           0.00

```

Figure 21-6. **onstat -C** command output with the clean option

Output description using the clean option

Partnum

The partition number for an index

Key Index Key

Dirty Hits

Number of times a dirty page has been scanned

Clean Time

Total time spent, in seconds

Pg Examined

Number of pages examined by btscanner thread

Items Del

Number of items removed form this index

Pages/Sec

Number of pages examined per second

C Indicates partition is busy being cleaned

N index partition is no longer eligible for cleaning

Example Output

```

Btree Cleaner Info

Cleaning Range Statistics
=====
Partnum Key      Low          High          Size          Saving
0x001001bc 2          36           69           96           65.6 %
0x001001be 1          16           20           48           91.7 %
0x001001cd 1          8            21           32           59.4 %
0x001001cd 2          24           25           32           96.9 %

```

Figure 21-7. **onstat -C** range

Output Description

Partnum

The partition number

Key Index Key

Low Low boundary for range scan

High High boundary for index scan

Size Size of index in pages

Saving Percentage of time saved versus a full scan

C Indicates partition is busy being cleaned

N Index partition is no longer eligible for cleaning

Example Output

```
Btree Cleaner Info

ALICE Bitmap of Deleted Index Items
=====
Partnum  Key      Map
0x00100013 2 0000: 80000000 00000000
0x0010008b 3 0000: 80000000 00000000
0x001000c7 1 0000: 80000000 00000000
0x00100150 2 0000: 80000000 00000000
0x0010016f 2 0000: 80000000 00000000
0x00100191 1 0000: 80000000 00000000
0x00100191 2 0000: 80000000 00000000
0x00a00011 2 0000: 80000000 00000000
0x00a00013 1 0000: 00000000 00000000
0x00a00019 1 0000: 00000000 00000000
0x00a00022 1 0000: 80000000 00000000
0x00a00022 2 0000: 80000000 00000000
```

Figure 21-8. `onstat -C` map

Output Description

Partnum

The partition number

Key Index Key

Map Alice bitmap

Example Output

```

Btree Cleaner Info

ALICE Cleaning Statistics
=====

System ALICE Info: Mode =    6, Eff =    30 %, Adj =    5

Partnum   Mode  BM_Sz  Used_Pg  Examined  Dirty_Pg  # I/O  Found   Eff   Adj
0x00100013  6    64    97        0         0         0     0    0.0 %  0
0x0010008b  6    64     5         0         0         0     0    0.0 %  0
0x001000c7  6    64     2         0         0         0     0    0.0 %  0
0x00100150  6    64    91         0         0         0     0    0.0 %  0
0x0010016f  6    64    91         0         0         0     0    0.0 %  0
0x00100191  6    64    26         0         0         0     0    0.0 %  0
0x00100191  6    64    26         0         0         0     0    0.0 %  0
0x001001bc  0     0    91         0         0         0     0    0.0 %  0
0x001001cd  0     0    26         0         0         0     0    0.0 %  0
0x001001cd  0     0    26         0         0         0     0    0.0 %  0
0x00a00011  6    64    91         0         0         0     0    0.0 %  0
0x00a00013  6    64    25         24         3         3     1   33.3 %  1
0x00a00019  6    64   470        470         3         3     2   66.7 %  1
0x00a00022  6    64    26         0         0         0     0    0.0 %  0
0x00a00022  6    64    26         0         0         0     0    0.0 %  0

```

Figure 21-9. **onstat -C** alice

Output Description

Partnum

The partition number for an index

Mode

The alice mode for the current partition

BM_Sz

The size allocated for the bitmap

Used_Pg

The size of the index in pages (used)

Dirty_Pg

Number of dirty pages

I/O

Number of pages read

Found

Number of dirty pages found in reads

Eff

How efficient was the bitmap

Adj

Number of times the alice efficiency level for the partition was insufficient and was adjusted

onstat -d command: Print chunk information

Use the **onstat -d** command to display information about chunks in each storage space.

Syntax:

▶▶ onstat -d ◀◀

Using onstat -d with sbspaces

For information about using **onstat -d** to determine the size of sbspaces, user-data areas, and metadata areas, see monitoring sbspaces in the *IBM Informix Administrator's Guide*.

Using onstat -d with blobspaces

If you issue the **onstat -d** command on an instance with blobspace chunks, the database server displays the following message:

NOTE: For BLOB chunks, the number of free pages shown is out of date.
Run 'onstat -d update' for current stats.

To obtain the current statistics for blobspace chunks, issue the **onstat -d update** command. The **onstat** utility updates shared memory with an accurate count of free pages for each blobspace chunk. The database server displays the following message:

Waiting for server to update BLOB chunk statistics ...

Example output

You can interpret output from this option as follows.

```
BM Informix Dynamic Server Version 11.70.F      -- On-Line -- Up 00:01:27 -- 133540 Kbytes

Dbspaces
address  number  flags      fchunk  nchunks  pgsize  flags  owner   name
48750028 1       0x60001   1       1        2048   N BA   informix rootdbs
4a0bee00 2       0x60001   2       1        2048   N BA   informix dbspace2
  2 active, 2047 maximum

Chunks
address  chunk/dbs  offset  size   free   bpages  flags  pathname
487501c8 1          1      0     1000000 923615  PO-B-- /dev/raw/raw1
49f1bda0 2          2      0      5000    4972   PO-BED /work2/dbspaces/dbs2
  2 active, 32766 maximum

Chunks
address  chunk/dbs  offset  size   free   bpages  flags  pathname
460bb1c0 1          1      0      60000  24387  PO-B-D /work8/root_chunk
460bb7a0 2          3      0      2500   2447   PO-BED /work8/dbspaces/cook1
460bb990 3          4      0      2500   2447   PO-BED /work8/dbspaces/cook2
460bbb80 4          5      0     10000  9947   PO-BE- /work8/dbspaces/dbtmp
460bbd70 5          6      0    100000 30483   PO-BED /work8/dbspaces/dbs1
  5 active, 32766 maximum

NOTE: The values in the "size" and "free" columns for DBspace chunks are
      displayed in terms of "pgsize" of the DBspace to which they belong.

Expanded chunk capacity mode: always
```

Figure 21-10. **onstat -d** command output

Output description - Dbspaces

The first section of the display describes the storage spaces:

address Is the address of the storage space in the shared-memory space table

number

Is the unique ID number of the storage space assigned at creation

flags

Uses hexadecimal values to describe each storage space. The individual flag values can be summed to show cumulative properties of the dbspace. The following table describes each hexadecimal value:

Table 21-21. Descriptions for each hexadecimal value

Flag Value	Description
0x00000000	Mirror not allowed and dbspace is unmirrored
0x00000001	Mirror is allowed and dbspace is unmirrored
0x00000002	Mirror is allowed and dbspace is mirrored
0x00000004	Down
0x00000008	Newly mirrored
0x00000010	Blobspace
0x00000020	Blobspace on removable media
0x00000040	Blobspace is on optical media
0x00000080	Blobspace is dropped
0x00000100	Blobspace is the optical STAGEBLOB
0x00000200	Space is being recovered
0x00000400	Space is fully recovered
0x00000800	Logical log is being recovered
0x00001000	Table in dbspace is dropped
0x00002000	Temporary dbspace
0x00004000	Blobspace is being backed up
0x00008000	Sbospace
0x00010000	Physical or logical log changed
0x00020000	Dbspace or chunk tables have changed
0x00040000	Dbspace or blobspace contains large chunk
0x00080000	Chunk in this dbspace has been renamed
0x00100000	Temporary dbspace used by only by shared disk secondary server. It is one of the dbspaces listed in the SDS_TEMPDBS configuration parameter on the SD secondary server.
0x00200000	Temporary dbspace for the SD secondary server. This is listed in the DBSPACETEMP configuration parameter on the shared disk secondary server.
0x00400000	The dbspace was externally backed up.

fchunk The ID number of the first chunk

nchunks

The number of chunks in the storage space

pgsize

The size of the dbspace pages in bytes

flags

Uses the following letter codes to describe each storage space:

Position 1:

Flag	Description
M	Mirrored
N	Not mirrored

Position 2:

Flag	Description
X	Newly mirrored
P	Physically recovered, waiting for logical recovery
L	Being logically recovered
R	Being recovered
D	Down

Position 3:

Flag	Description
B	Blobspace
S	Sbpace
T	Temporary dbspace
U	Temporary sbpace
W	Temporary dbspace on primary server (This flag is shown on SD secondary servers only.)

Position 4:

Flag	Description
B	The dbspace can have large chunks that are greater than 2 GB.

Position 5:

Flag	Description
A	The dbspace is auto-expandable, because the SP_AUTOEXPAND configuration parameter is enabled and the dbspace is configured with a create size or extend size that is not zero.

owner The owner of the storage space

name The name of the storage space

In the line immediately following the storage-space list, **active** refers to the current number of storage spaces in the database server instance including the rootdbs and **maximum** refers to total *allowable* spaces for this database server instance.

Output description - Chunks

The second section of the **onstat -d** command output describes the chunks:

address

The address of the chunk

chk/db

The chunk number and the associated space number

offset The offset into the file or raw device in base page size

size The size of the chunk in terms of the page size of the dbspace to which it belongs.

free The number of unallocated pages in the chunk in units of the page size of the associated dbspace. A value of 0 indicates that all the space in the chunk has been allocated to tables, but does not indicate how much space is free inside the tables. For example, suppose you create a dbspace with one chunk of 200 MB and create one table with an extent size of 200 MB. The value of the **free** field is 0, indicating that the chunk has no free space, however, the new empty table has 200 MB of free space.

For a blob space, a tilde indicates an approximate number of unallocated blob pages.

For an sbspace, indicates the number of unallocated pages of user data space and total user data space.

bpages

Is the size of the chunk in blob pages

Blob pages can be larger than disk pages; therefore, the **bpages** value can be less than the **size** value.

For an sbspace, is the size of the chunk in sbpages.

flags Provides the chunk status information as follows:

Position 1:

Flag	Description
P	Primary
M	Mirror

Position 2:

Flag	Description
N	Renamed and either Down or Inconsistent
O	Online
D	Down
X	Newly mirrored
I	Inconsistent

Position 3:

Flag	Description
-	Dbspace
B	Blob space
S	Sbspace

Position 4:

Flag	Description
B	The dbspace can have large chunks that are greater than 2 GB.

Position 5:

Flag	Description
E	Identifies the chunk as extendable
-	Identifies the chunk as not extendable

Position 6:

Flag	Description
-	Not using the direct I/O or concurrent I/O option for this cooked file chunk
C	On AIX, using the concurrent I/O option for this cooked file chunk
D	Using the direct I/O option for this cooked file chunk

pathname

The pathname of the physical device

In the line immediately following the chunk list, **active** displays the number of active chunks (including the root chunk) and **maximum** displays the total number of chunks.

For information about page reads and page writes, refer to “**onstat -D** command: Print page-read and page-write information.”

Related reference:

“modify chunk extend argument: Extend the size of a chunk (SQL administration API)” on page 22-66

onstat -D command: Print page-read and page-write information

Use the **onstat -D** command to display page-read and page-write information for the first 50 chunks in each space.

Syntax:

▶▶ onstat -D ▶▶

Example output

```

Dbspaces
address number flags fchunk nchunks pgsz flags owner name
a40d7d8 1 0x1 1 1 2048 N informix rootdbs
1 active, 2047 maximum

Chunks
address chunk/dbs offset page Rd page Wr pathname
a40d928 1 1 0 0 0 /work/11.1/dbspaces/stardbs3
1 active, 2047 maximum

Expanded chunk capacity mode: disabled

```

Figure 21-11. **onstat -D** command output

Output description

The output of **onstat -D** is almost identical to the output of **onstat -d**. The following columns are unique to **onstat -D**. For information on the other output columns see “**onstat -d** command: Print chunk information” on page 21-34.

page Rd

Is the number of pages read

page Wr

Is the number of pages written

onstat -f command: Print dbspace information affected by dataskip

Use the **-f** command to list the dbspaces that the dataskip feature currently affects.

Syntax:

▶▶—onstat— -f—▶▶

The **-f** option lists both the dbspaces that were set with the DATASKIP configuration parameter and the **-f** option of **onspaces**. When you execute **onstat -f**, the database server displays one of the following three outputs:

- Dataskip is OFF for all dbspaces.
- Dataskip is ON for all dbspaces.
- Dataskip is ON for the following dbspaces:
dbspace1 dbspace2...

Related reference:

“DATASKIP Configuration Parameter” on page 1-42

onstat -F command: Print counts

Use the **onstat -F** command to display a count for each type of write that flushes pages to disk.

Syntax:

▶▶—onstat— -F—▶▶

Example output

Fg Writes	LRU Writes	Chunk Writes							
0	330	7631							
address	flusher	state	data	# LRU	Chunk	Wakeups	Idle Time		
c7c8850	0	I	0	9	29	16116	16093.557		
			states:	Exit	Idle	Chunk	Lru		

Figure 21-12. **onstat -F** command output

Output description

You can interpret output from this option as follows:

Fg Writes

Is the number of times that a foreground write occurred

LRU Writes

Is the number of times that an LRU write occurred

Chunk Writes

Is the number of times that a chunk write occurred

address Is the address of the user structure assigned to this page-cleaner thread

flusher Is the page-cleaner number

state Uses the following codes to indicate the current page-cleaner activity:

- C** Chunk write
- E** Exit
- I** Cleaner is idle
- L** LRU queue

The exit code indicates either that the database server is performing a shutdown or that a page cleaner did not return from its write in a specific amount of time. When an operation fails to complete within the allotted time, this situation is known as a time-out condition. The database server does not know what happened to the cleaner, so it is marked as `exit`. In either case, the cleaner thread eventually exits.

data Provides additional information in concert with the **state** field

If **state** is **C**, **data** is the chunk number to which the page cleaner is writing buffers. If **state** is **L**, **data** is the LRU queue from which the page cleaner is writing. The **data** value is displayed as a decimal, followed by an equal sign, and repeated as a hexadecimal.

#LRU Corresponds to the **onstat -g ath** thread ID output

Chunk

Number of chunks cleaned

Wakeups

Number of times the flusher thread was awoken

Idle Time

Time in seconds the flusher thread has been idle

onstat -g monitoring options

The options that you can use with **onstat -g** command are used for support and debugging only. You can include only one of these options in the **onstat -g** command.

The following table lists the **onstat -g** options. For more information, see the *IBM Informix Performance Guide*.

onstat -g Option	Topic or Function
-g act	Prints active threads. See “ onstat -g act command: Print active threads” on page 21-48.
-g afr	Prints allocated memory fragments for a specified session or shared-memory pool. Each session is allocated a pool of shared memory. To obtain the pool name, see the -mem option. See “ onstat -g afr command: Print allocated memory fragments” on page 21-48.
-g all	Prints output from all onstat -g options. See “ onstat -g all command: Print diagnostic information” on page 21-49.
-g aqt	Prints information about the data marts and the associated accelerated query tables (AQTs). See “ onstat -g aqt command: Print data mart and accelerated query table information” on page 21-49.
-g ath	Prints all threads. The sqlmain threads represent client sessions. The rstcb value corresponds to the user field of the onstat -u command. See “ onstat -g ath command: Print information about all threads” on page 21-54. For information about using onstat -g ath to print Enterprise Replication threads, see the <i>IBM Informix Enterprise Replication Guide</i> .
-g buf	Prints profile information for each buffer pool. See “ onstat -g buf command: Print buffer pool profile information” on page 21-55.
-g cat	Prints information from the Enterprise Replication global catalog. The global catalog contains a summary of information about the defined servers, replicates, and replicate sets on each of the servers within the enterprise. See “ onstat -g cat command: Print ER global catalog information” on page 21-57.
-g cac agg	Prints the definitions for user-defined aggregates that are currently in the cache.
-g cac stmt	Prints the contents of the SQL statement cache. Prints the same output as the -g ssc option.
-g cdr	Prints the settings of Enterprise Replication configuration parameters and environment variables. See “ onstat -g cdr config command: Print ER settings” on page 21-59.
-g ckp	Prints the checkpoint history and displays configuration recommendations if a suboptimal configuration is detected. See “ onstat -g ckp command: Print checkpoint history and configuration recommendations” on page 21-61.
-g cluster	Prints high-availability cluster information. See “ onstat -g cluster command: Print high-availability cluster information” on page 21-65.
-g cmsm	Prints Connection Manager daemon instances and displays the number of connections each daemon has processed. See “ onstat -g cmsm command: Print Connection Manager information” on page 21-69.
-g con	Prints conditions with waiters. See “ onstat -g con command: Print condition and thread information” on page 21-71.

onstat -g Option	Topic or Function
-g cpu	Prints information about runtime statistics for all the threads running in the server. See “ onstat -g cpu : Print runtime statistics” on page 21-71.
-g dbc	Prints information for database scheduler and the SQL administration API. See “ onstat -g dbc command: Print dbScheduler and dbWorker thread statistics” on page 21-73.
-g ddr	Prints the status of the Enterprise Replication database log reader. If log reading is blocked, data might not be replicated until the problem is resolved. See “ onstat -g ddr command: Print ER database log reader status” on page 21-74.
-g dic	Prints one line of information for each table cached in the shared-memory dictionary. If given a specific table name as a parameter, prints internal SQL information for that table. For more information, see your <i>IBM Informix Performance Guide</i> . For sample output, see “ onstat -g dic command: Print table information” on page 21-76.
-g dis	Prints a list of database servers and their status, and information about each database server, INFORMIXDIR , sqlhosts file, ONCONFIG file, and hostname. See “ onstat -g dis command: Print database server information” on page 21-77.
-g dll	Prints a list of dynamic libraries that have been loaded. See “ onstat -g dis command: Print database server information” on page 21-77.
-g dmp	Prints raw memory at a given address for a number of given bytes. See “ onstat -g dmp command: Print raw memory” on page 21-80.
-g dri	Prints data-replication information. See monitoring High-Availability Data-Replication status in the <i>IBM Informix Administrator's Guide</i> . See “ onstat -g dri command: Print high-availability data replication information” on page 21-81.
-g dsc	Prints data-distribution cache information. See “ onstat -g dsc command: Print distribution cache information” on page 21-83.
-g dss	Prints detailed statistical information about the activity of individual data sync threads and about user-defined data types. See “ onstat -g dss command: Print ER environment data” on page 21-84.
-g dsk	Prints information that shows the progress of currently running compression operations, such as compress, repack, and uncompress. See “ onstat -g dsk command: Print the progress of the currently running compression operation” on page 21-78.
-g dtc	Prints statistics about the delete table cleaner which removes rows from the delete table when they are no longer needed. See “ onstat -g dtc command: Print delete table cleaner statistics” on page 21-85.
-g env	Prints the values of environment variables the database server currently uses. See “ onstat -g env command: Print environment variable values” on page 21-86.
-g ffr	Prints free fragments for a pool of shared memory. See “ onstat -g ffr command: Print free fragments” on page 21-88.
-g glo	Prints global multithreading information. This information includes CPU use information about the virtual processors, the total number of sessions, and other multithreading global counters. On Windows, the virtual processors are operating system threads. The values displayed under the pid field are thread IDs not process IDs. (Windows). See “ onstat -g glo command: Print global multithreading information” on page 21-89.

onstat -g Option	Topic or Function
-g grp	Prints statistics about the Enterprise Replication grouper. The grouper evaluates the log records, rebuilds the individual log records into the original transaction, packages the transaction, and queues the transaction for transmission. See “ onstat -g grp command: Print ER grouper statistics” on page 21-91.
-g his	Prints information about the SQLTrace configuration parameter. See “ onstat -g his command: Print SQL trace information” on page 21-97.
-g imc	Prints information about Informix MaxConnect instances that are connected to the database server. If Informix MaxConnect is not connected to the database server, this command displays No MaxConnect servers are connected.
-g ioa	Prints combined information from the -g ioq and -g iov command. See “ onstat -g ioa command: Print combined onstat -g information” on page 21-102.
-g iob	Prints the big buffer usage summary. See “ onstat -g iob command: Print big buffer use summary” on page 21-103.
-g iof	Prints asynchronous I/O statistics by chunk or file. This option is similar to the -D option, except it also displays information about nonchunk, temporary, and sort-work files. See “ onstat -g iof command: Print asynchronous I/O statistics” on page 21-104.
-g iog	Prints AIO global information. See “ onstat -g iog command: Print AIO global information” on page 21-105.
-g ioq	Prints pending I/O operations for the <i>queue name</i> . If given the <i>gfd</i> or <i>kaio</i> queue name, a queue for each CPU VP is displayed. If <i>queue name</i> is omitted, I/O statistics for all queues are displayed. See “ onstat -g ioq command: Print I/O queue information” on page 21-105.
-g iov	Prints asynchronous I/O statistics by virtual processor. See “ onstat -g iov command: Print AIO VP statistics” on page 21-107.
-g ipl	Prints index page logging status. See “ onstat -g ipl command: Print index page logging status information” on page 21-107.
-g lap	Prints information about the status of light appends. See “ onstat -g lap command: Print light appends status information” on page 21-109.
-g laq	Prints information about queues on the secondary server. See “ onstat -g laq command: Print secondary server queues” on page 21-109.
-g lmm	Prints information about automatic low memory management settings and recent activity. See “ onstat -g lmm command: Print low memory management information” on page 21-111.
-g lmx	Prints all locked mutexes. See “ onstat -g lmx command: Print all locked mutexes” on page 21-113.

onstat -g Option	Topic or Function
-g mem	<p>Prints statistics for a memory pool. Also prints the pool name, type of shared memory segment that contains the pool, the address of the pool, the total size of the pool, the number of bytes of free memory that it contains, and the number of free and allocated fragments in the pool. If no argument is provided, displays information about all pools. The block pools are listed in a separate section after the main pool list.</p> <p>You also can use ISA to obtain detailed information about a memory pool. If you run an SQL query that allocates memory from the PER_STMT_EXEC and PER_STMT_PREP memory duration pools, the onstat -g mem command displays information about the PRP.sessionid.threadid pool and the EXE.sessionid.threadid pool.</p> <p>See “onstat -g mem command: Print pool memory statistics” on page 21-114. For more information, see the <i>IBM Informix DataBlade API Programmer’s Guide</i>.</p>
-g mgm	Prints Memory Grant Manager resource information. See “ onstat -g mgm command: Print MGM resource information” on page 21-116.
-g nbm	Prints block bit map for the nonresident segments, one bit per 8-kilobyte block. Bit set indicates block free. See “ onstat -g nbm command: Print a block bit map” on page 21-119.
-g nif	Prints statistics about the network interface. This command is useful to determine why data is not replicating. See “ onstat -g nif command: Print statistics about the network interface” on page 21-120.
-g nsc	Prints shared-memory status by <i>client id</i> . If <i>client id</i> is omitted, all client status areas are displayed. This command prints the same status data as the nss option. See “ onstat -g nsc command: Print current shared memory connection information” on page 21-121.
-g nsd	Prints network shared-memory data for poll threads. See “ onstat -g nsd command: Print poll threads shared-memory data” on page 21-124.
-g nss	Prints network shared-memory status by <i>session id</i> . If <i>session id</i> is omitted, all session status areas are displayed. This command prints the same status data as the nsc option. See “ onstat -g nss command: Print shared memory network connections status” on page 21-124.
-g nta	Prints combined network statistics from the -g ntd , -g ntm , -g ntt , and -g ntu commands. If Informix MaxConnect is installed, this command prints statistics that you can use to tune Informix MaxConnect performance.
-g ntd	Prints network statistics by service. See “ onstat -g ntd command: Print network statistics” on page 21-125.
-g ntm	Prints network mail statistics. See “ onstat -g ntm command: Print network mail statistics” on page 21-126.
-g ntt	Prints network user times. See “ onstat -g ntt command: Print network user times” on page 21-126.
-g ntu	Prints network user statistics. See “ onstat -g ntu command: Print network user statistics” on page 21-127.
-g opn	Prints open partitions. See “ onstat -g opn command: Print open partitions” on page 21-127.

onstat -g Option	Topic or Function
-g osi	Prints information about operating system resources and parameters. See “ onstat -g osi : Print operating system information” on page 21-129.
-g pos	Prints \$INFORMIXDIR/etc/ .infos.DBSERVERNAME file for UNIX or the %INFORMIXDIR%\etc\ .infos.DBSERVERNAME file for Windows. See “ onstat -g pos command: Print file values” on page 21-130.
-g ppd	Prints information about compressed fragments (also referred to as partitions) and the compression dictionary. See “ onstat -g ppd command: Print partition compression dictionary information” on page 21-131.
-g ppf	Prints partition profile for the specified partition number or prints profiles for all partitions. See “ onstat -g ppf command: Print partition profiles” on page 21-132.
-g pqs	Prints SQL statement information. You can display information for all sessions or for a specific <i>sessionid</i> . See “ onstat -g pqs command: Print operators for all SQL queries” on page 21-133.
-g prc	Prints information about SPL routine cache. See “ onstat -g prc command: Print sessions using UDR or SPL routine” on page 21-134.
-g proxy	Prints proxy distributor information. See “ onstat -g proxy command: Print proxy distributor information” on page 21-135.
-g qst	Prints queue wait statistics. See “ onstat -g qst command: Print wait options for mutex and condition queues” on page 21-141.
-g que	Prints statistics for the high-level queue interface (which are common to all the queues of the Enterprise Replication Queue Manager. See “ onstat -g que command: Prints ER queue statistics” on page 21-140.
-g rbm	Prints block bit map for the resident segment (communication message area). See “ onstat -g rbm command: Print a block map of shared memory” on page 21-143.
-g rcv	Prints statistics about the receive manager, which is a set of service routines between the receive queues and data sync. See “ onstat -g rcv command: Print ER receive manager statistics” on page 21-144.
-g rea	Prints ready threads. See “ onstat -g rea command: Print ready threads” on page 21-147.
-g rep	Prints events that are in the queue for the schedule manager. See “ onstat -g rep command: Print ER schedule manager events” on page 21-148.
-g rqm	Prints statistics and contents of the low-level queues (each individual queue) managed by the Reliable Queue Manager (RQM). See “ onstat -g rqm command: Print low-level queue statistics” on page 21-148.
-g rss	Prints remote standalone secondary (RSS) server information. See “ onstat -g rss command: Print RS secondary server information” on page 21-151.
-g rwm	Prints read/write mutexes. See “ onstat -g rwm command: Print read and write mutexes” on page 21-154.
-g sch	Prints the number of semaphore operations, spins, and busy waits for each virtual processor. On Windows, the virtual processors are operating system threads. The values displayed under the pid field are thread IDs not process IDs. See “ onstat -g sch command: Print VP information” on page 21-155.

onstat -g Option	Topic or Function
-g scn	Prints information about scans based on rows scanned. See “ onstat -g scn command: Print scan information” on page 21-155
-g sds	Prints shared disk secondary (SDS) server information. See “ onstat -g sds command: Print SD secondary server information” on page 21-157.
-g seg	Prints shared-memory-segment statistics. This option shows the number and size of shared-memory segments that the database server is currently using. See “ onstat -g seg command: Print shared memory segment statistics” on page 21-161.
-g ses	Prints session information by <i>sessionid</i> . If <i>sessionid</i> is missing, a one-line summary of each session prints. See “ onstat -g ses command: Print session-related information” on page 21-162.
-g sle	Prints all sleeping threads. See “ onstat -g sle command: Print all sleeping threads” on page 21-167.
-g smb	Prints detailed information about sbspaces. See “ onstat -g smb command: Print sbspaces information” on page 21-167.
-g smx	Displays server multiplexer group connections information. See “ onstat -g smx command: Print multiplexer group information” on page 21-169.
-g spi	Prints spin locks with long spins. See “ onstat -g spi command: Print spin locks with long spins” on page 21-171.
-g sql	Prints SQL information by <i>session id</i> . If <i>session id</i> is omitted, a one-line summary for each session prints. See “ onstat -g sql command: Print SQL-related session information” on page 21-172.
-g src	Searches for patterns in shared memory. See “ onstat -g src command: Patterns in shared memory” on page 21-173.
-g ssc	Monitors the number of times that the database server reads the SQL statement in the cache. Optional keywords include all and pool . For the syntax, option descriptions, and example output, see “ onstat -g ssc command: Print SQL statement occurrences” on page 21-174. Displays the same output as onstat -g cac stmt . For more information, see improving query performance in the <i>IBM Informix Performance Guide</i> .
-g stk	Prints the stack of a specified thread or prints stacks for <i>all</i> threads. This option is not supported on all platforms and is not always accurate. See “ onstat -g stk command: Print thread stack” on page 21-176.
-g stm	Prints the memory that each prepared SQL statement uses. See “ onstat -g stm command: Print SQL statement memory usage” on page 21-176. For more information, see memory utilization and improving query performance in the <i>IBM Informix Performance Guide</i> .
-g stq	Prints queue stream information. See “ onstat -g stq command: Print queue information” on page 21-177.
-g sts	Prints maximum and current stack use per thread. See “ onstat -g sts command: Print stack usage for each thread” on page 21-177.
-g sync	Prints which sync is active. See “ onstat -g sync command: Print ER synchronization status” on page 21-179.
-g tpf	Prints thread profile for a specific thread ID. See “ onstat -g tpf command: Print thread profiles” on page 21-180.

onstat -g Option	Topic or Function
-g ufr	Prints allocated fragments by use. See “ onstat -g ufr command: Print memory pool fragments” on page 21-181.
-g vpcache	Prints information about CPU VP memory block cache statistics. See “ onstat -g vpcache command: Print CPU VP memory block cache statistics” on page 21-182.
-g wai	Prints waiting threads; all threads waiting on mutex or condition, or yielding. See “ onstat -g wai command: Print wait queue thread list” on page 21-184.
-g wmx	Prints all mutexes with waiters. See “ onstat -g wmx command: Print all mutexes with waiters” on page 21-184.
-g wst	Prints wait statistics for threads. See “ onstat -g wst command: Print wait statistics for threads” on page 21-185.

onstat -g act command: Print active threads

Use the **onstat -g act** command to display information about the active threads.

Syntax:

```
▶▶ onstat -g act ◀◀
```

Following is sample output from the **onstat -g act** command. For a description of the output, see “**onstat -g ath** command: Print information about all threads” on page 21-54.

Example output

Running threads:							
tid	tcb	rstcb	prty	status	vp-class	name	
2	b3132d8	0	1	running	*2adm	adminthd	
40	c5384d0	0	1	running	*1cpu	tlitcpoll	

Figure 21-13. **onstat -g act** command output

onstat -g afr command: Print allocated memory fragments

Use the **onstat -g afr** command to display information about the allocated memory fragments for a specified session or shared-memory pool. Each session is allocated a pool of shared memory.

This command requires an additional argument to specify either a pool name or session ID whose memory pool information is to be displayed. Each session is allocated a memory pool with the same name as the session ID. Use the **onstat -g mem** command to identify the pool name and the **onstat -g ses** command to identify the session ID.

Syntax:

```
▶▶ onstat -g afr [pool_name | sessionid] ◀◀
```

Example output

```
Allocations for pool name global:
addr          size    memid    fileid  location
4b231000     3288   overhead 306     mtshpool.c:617
4b231cd8      72     mcbmsg   1637    rldmsg.c:92
4b231d20     160    mcbmsg   1637    rldmsg.c:92
4b231dc0      64     osendv   2909    osendv.c:1164
4b231e00      64     osendv   2909    osendv.c:1971
4b231e40      64     osendv   2909    osendv.c:1164
4b231e80      64     osendv   2909    osendv.c:1971
```

Figure 21-14. `onstat -g afr` command output

Output description

addr (hexadecimal)

Memory address of the pool fragment.

size (decimal)

Size, in bytes, of the pool fragment.

memid (string)

Memory ID of the pool fragment.

fileid (decimal)

Internal use only. Code file identifier for the allocation.

location (string)

Internal use only. Line number in the code for the allocation.

onstat -g all command: Print diagnostic information

Use the `onstat -g all` command to gather diagnostic information if advised to do so by IBM Support. For normal administrative purposes, use the `onstat -g` command with individual options.

Syntax:

```
▶▶ onstat -g all ◀◀
```

onstat -g aqt command: Print data mart and accelerated query table information

Use the `onstat -g aqt` command to display information about the data marts and the associated accelerated query tables (AQTs).

Syntax:

```
▶▶ onstat -g aqt [ aqt_name ] ◀◀
```

Example output

```

AQT Dictionary Cache for database school:

mart: school
accelerator: DWAFINAL
last load: 2011/07/29 07:00:39

AQT name                               FactTab #tab #matched  address
-----
aqt4d11b552-7d41-4b0c-824b-7714b6cb580a  103   1    328    0x4d187e08
aqt61498fab-3617-4c8c-ab40-fd8af4253998  103   2     42    0x4d84a448
aqtbc2da77c-bca8-4ce7-9191-8180a860da34  103   2    768    0x4d187f60
aqt88757e9d-81ee-43b4-87b2-0bf48c98fa55  103   3     15    0x4d84a190
aqt786d0dc-8e95-4de0-a1bd-773aa03a52db  103   3   1475    0x4d84a650
aqt8dd61c80-2c1c-4f0e-8f0c-91babe789f41  103   4    632    0x4d84a908

mart: school2
accelerator: DWAFINAL
last load: 2011/07/29 07:01:04

AQT name                               FactTab #tab #matched  address
-----
aqt56d5aea7-32f4-44e6-8d98-02a7af37630f  103   1    845    0x4d84ac70
aqt03ec4c20-7ba8-4c3a-ae56-4134b005269d  103   2     27    0x4d95c298
aqt4ae7c2fd-5b94-423d-bc49-9ca3f5f38799  103   2   3912    0x4d84adc8
aqt5ed69a75-15e3-45cc-9892-4f5386257895  103   3     83    0x4d95c4a0
aqtdf314aa6-177d-4443-9f6d-f14ba766995a  103   3     37    0x4d95c028
aqt7e36b1f2-4646-4075-ac0b-5fdee475cd7e  103   4    518    0x4d95c758

mart: school3
accelerator: DWAFINAL
last load: 2011/07/29 07:01:50

AQT name                               FactTab #tab #matched  address
-----
aqt92b36a8a-1567-4146-833c-385cd103f5d4  103   1    678    0x4d95cac0
aqt3189bec1-b6c9-417d-b969-92c687ef2e44  103   2     59    0x4d95cc18
aqt8d3b3dc8-59b6-4e34-822b-75b06b99c900  103   2   4487    0x4d90c0d8
aqt5f9c2a05-9131-4738-a929-036fcf77f65c  103   3     71    0x4d90c2e0
aqttee08ed16-6a5c-4478-ac57-fc4f99539c74  103   3    795    0x4d95ce20
aqt04d1c96a-022b-4ed7-938d-caf765bc9926  103   4    367    0x4d90c598

18 entries

```

Figure 21-15. `onstat -g aqt` command output

If you use the AQT name for the optional `aqt_name` parameter, the command prints information about the specific AQT.

```

AQT: aqt6de1afdd-f10a-45b0-93e9-0c208405fefd
database: iwadb
AQT tabid: 125
Fact table: 111
Number of times matched: 8947

Join structure: alias(tabid)[colno,...] = alias(tabid)[colno,...] {u:unique}
0(111)[1] = 1(110)[1] u
           1(110)[2] = 2(109)[1] u
                       2(109)[5] = 3(101)[1] u
                                   3(101)[3] = 4(100)[1] u

0(111)[2] = 5(106)[1] u
           5(106)[2] = 6(103)[1] u
           5(106)[3] = 7(104)[1] u
           5(106)[4] = 8(105)[1] u
                       8(105)[3] = 9(101)[1] u
                                   9(101)[3] = 10(100)[1] u

           5(106)[5] = 11(102)[1] u
0(111)[2,3] = 15(108)[1,2] u
              15(108)[1] = 16(106)[1] u
                          16(106)[2] = 17(103)[1] u
                          16(106)[3] = 18(104)[1] u
                          16(106)[4] = 19(105)[1] u
                                  19(105)[3] = 20(101)[1] u
                                          20(101)[3] = 21(100)[1] u

              16(106)[5] = 22(102)[1] u
15(108)[2] = 23(107)[1] u
              23(107)[2] = 24(101)[1] u
                                  24(101)[3] = 25(100)[1] u

0(111)[3] = 12(107)[1] u
           12(107)[2] = 13(101)[1] u
                       13(101)[3] = 14(100)[1] u

```

Figure 21-16. `onstat -g aqt aqt_name` command output

Output description

The AQTs are grouped by the data mart that they belong to. The groups are sorted by accelerator name, and then by data mart name. Within the data mart groups, the AQTs are sorted in the following order: Fact table tabid (FactTab), number of tables (#tab), and AQT name.

The output comes from the entries in the dictionary cache that refer to the AQTs of the data marts. The output is shown only if the AQTs have been loaded into the dictionary cache, which normally occurs when a query is being matched against the AQTs.

Before the server attempts to match a query against the AQTs, the AQTs do not have any entries in the dictionary cache. The `onstat -g aqt` command will not show any entries in the output. When the dictionary cache is initialized during the database server startup, the columns #matched and address get new values.

The `onstat -g aqt` command prints the following information:

mart The name of the data mart

accelerator

The name of the accelerator instance

last load

The time stamp for when the data mart was last loaded

AQT name

The unique system-generated name of the AQT

FactTab

The tabid of the fact table for the AQT

#tab The number of tables that are part of the AQT

#matched

The counter for query matches that have occurred for the AQT

address

The internal database server memory address for the AQT

The **onstat -g aqt aqt_name** command prints the following information:

AQT The unique system-generated name of the AQT

database

The name of the database to which the AQT belongs

AQT tabid

The tabid for the entry that constitutes the AQT in the systables system catalog table of the database server.

Fact table

The tabid of the fact table of the AQT

Number of times matched

The counter for query matches that have occurred for the AQT

The information about the AQT is followed by a textual representation of the star schema of the data mart. The textual representation shows how the columns of the tables are related to each other in the star join.

For information about the Informix Warehouse Accelerator, see the *IBM Informix Warehouse Accelerator Administration Guide*.

onstat -g arc command: Print archive status

Use the **onstat -g arc** command to display information about the last committed archive for each dbspace and also information about any current ongoing archives.

Syntax:

▶▶ onstat -g arc ◀◀

Example output

```

Dbspaces - Ongoing archives
number  name           Q Size Q Len  buffer partnum   size   Current-page
1       rootdbs        100   3     100   0x1001c9    0      1:128
3       datadbs01     0      0
4       datadbs02     0      0

Dbspaces - Archive Status
name      number level date           log           log-position
rootdbs   1       0     07/30/2009.09:59 28           0x320018
datadbs01 3       0     07/30/2009.09:59 28           0x320018
datadbs02 4       0     07/30/2009.09:59 28           0x320018

```

Figure 21-17. `onstat -g arc` command output

Output description - Ongoing archives

This output section represents current information about the archives. If no archives are active in the system, this section is not displayed.

Column	Description
Number	The number of the dbspace
Name	The name of the dbspace
Q Size	The before-image queue list size. This information is primarily for IBM support.
Q Len	The before-image queue length. This information is primarily for IBM support.
Buffer	The number of pages used in the before-image buffer
Partnum	The partition number of the before-image bin
Size	The number of pages in the before-image bin
Current-page	The current page that is being archived

Note: The before-image bin is a temporary table created in a temporary dbspace, or in the root dbspace if you do not have any temporary dbspaces. If the before-image bin becomes too small, it can extend to additional partitions, in which case the output will display see multiple Partnum and Size fields for the same dbspace.

Output description - Archive status

This output section contains information about the last backup that has occurred for each dbspace.

Column	Description
Name	The name of the dbspace
Number	The dbspace number
Level	The archive level
Date	The date and time of the last archive

Column	Description
Log	The unique ID (UNIQID) of the checkpoint that was used to start the archive
Log-position	The log position (LOGPOS) of the checkpoint that was used to start the archive

onstat -g ath command: Print information about all threads

Use the **onstat -g ath** command to display information about all threads.

Syntax:

► onstat -g ath ◀

Example output

```
Threads:
tid    tcb          rstcb      prty status          vp-class    name
2      10bbf36a8    0          1    IO Idle          3lio       lio vp 0
3      10bc12218    0          1    IO Idle          4pio       pio vp 0
4      10bc31218    0          1    running          5aio       aio vp 0
5      10bc50218    0          1    IO Idle          6msc       msc vp 0
6      10bc7f218    0          1    running          7aio       aio vp 1
7      10bc9e540    10b231028  1    sleeping secs: 1 1cpu       main_loop()
8      10bc12548    0          1    running          1cpu       tlitcpoll
9      10bc317f0    0          1    sleeping forever 1cpu       tlitcplst
10     10bc50438    10b231780  1    IO Wait          1cpu       flush_sub(0)
11     10bc7f740    0          1    IO Idle          8aio       aio vp 2
12     10bc7fa00    0          1    IO Idle          9aio       aio vp 3
13     10bd56218    0          1    IO Idle          10aio      aio vp 4
14     10bd75218    0          1    IO Idle          11aio      aio vp 5
15     10bd94548    10b231ed8  1    sleeping forever 1cpu       aslogflush
16     10bc7fd00    10b232630  1    sleeping secs: 34 1cpu       btscanner 0
32     10c738ad8    10b233c38  1    sleeping secs: 1 1cpu       onmode_mon
50     10c0db710    10b232d88  1    IO Wait          1cpu       sqlxec
```

Figure 21-18. **onstat -g ath** command output

Output description

tid	Thread ID
tcb	Thread control block access
rstcb	RSAM thread control block access
prty	Thread priority
status	Thread status
vp-class	Virtual processor class
name	Thread name

Related reference:

“**onstat -g wst** command: Print wait statistics for threads” on page 21-185

“NUMFDSERVERS configuration parameter” on page 1-106

onstat -g buf command: Print buffer pool profile information

Use the **onstat -g buf** command to display profile information for each buffer pool.

Syntax:

►► onstat -g buf ◀◀

Example output

```
Profile
Buffer pool page size: 2048
dskreads pagreads bufreads %cached dskwrits pagwrits bufwrits %cached
53056 118251 982617385 99.99 10640768 10915965 15968877 33.37

bufwrits_sinceckpt bufwaits ovbuff flushes
17477 863 0 874

Fg Writes LRU Writes Avg. LRU Time Chunk Writes
0 0 NaN 110767

Fast Cache Stats
gets hits %hits puts
48314472 47220455 97.74 45757549
```

Figure 21-19. **onstat -g buf** command output

Output description

Buffer pool page size

Number of bytes in a page in the buffer pool being profiled

dskreads

Number of disk read operations performed to bring pages into this buffer pool. Each read operation reads one or more pages.

pagreads

Number of pages read from disk to this buffer pool

bufreads

Number of times a memory image for a page was read from this buffer pool

%cached

Percentage of page reads for this buffer pool that were satisfied by a cached page image (rather than having to perform a disk read). Computed as $(\text{bufreads} - \text{dskreads}) / \text{bufreads} \times 100$. Higher percentages indicate better caching performance.

dskwrits

Number of disk write operations performed to write changed pages from this buffer pool back to disk. Each write operation writes one or more pages.

pagwrits

Number of pages written to disk from this buffer pool

bufwrits

Number of times a memory image of a page was written to in this buffer pool

%cached

Percentage of page writes for this buffer pool that were satisfied by a cached page image (rather than having to perform a disk write). Computed as $(\text{bufwrits} - \text{dskwrits}) / \text{bufwrits} \times 100$.

bufwrits_sinceckpt

Number of times a memory image of a page was written to in this buffer pool since the last checkpoint

bufwaits

Number of times a thread had to wait for a lock on a buffer in this buffer pool. Higher numbers indicate more contention among multiple threads for mutually incompatible locks on the same pages.

ovbuff

Number of times a changed buffer from this buffer pool was written to disk specifically to create a free buffer to read another requested page. If the *ovbuff* value is high, it may indicate that the buffer pool is not large enough to hold the working set of pages needed by the applications using this buffer pool, which may lead to performance degradation from I/O thrashing.

flushes

Number of times the server performed a mass flush of all dirty buffers in the buffer pool. This can occur for a variety of reasons, including as part of checkpoint processing or if the buffer pool is running out of clean buffers despite normal LRU cleaning activity.

Fg Writes

Number of changed buffers from this buffer pool that were written to disk by a non-I/O flusher thread that was accessing the buffer. This number is a superset of *ovbuff*. In addition to the writes to service page faults counted by *ovbuff*, this value also includes foreground writes that are done by certain operations to maintain the consistency of database logs and reserved pages in order to guarantee correctness of crash recovery in special cases.

LRU Writes

Number of changed buffers from this buffer pool that were written to disk by an LRU cleaner thread. LRU cleaners are activated if the buffer pool exceeds the value specified in the **lru_max_dirty** field of the BUFFERPOOL configuration parameter or if foreground writes occur due to buffer pool overflows.

Avg. LRU Time

Average amount of time taken by an LRU cleaner thread to clean a single LRU chain.

Chunk Writes

Number of changed buffers that were written to disk by a chunk cleaning operation. Chunk cleaning writes out all changed buffers of a given chunk that are in the buffer pool. This is done in a variety of special circumstances that need to clean a large number of buffers quickly, such as checkpoint processing and fast recovery.

Fast Cache Stats

Statistics for the fast cache, which is a type of cache that reduces the time needed for accessing the bufferpool

- gets** The number of times the server looked for a buffer in the fast cache
- hits** The number of times that the server found the buffer it was searching for in the fast cache
- %hits** The percentage of hits, which is $\text{hits} \times 100 / \text{gets}$
- puts** The number of times that the server inserted buffers inserted into the fast cache

onstat -g cat command: Print ER global catalog information

Use the **onstat -g cat** command to display information from the Enterprise Replication global catalog. The global catalog contains information about the defined servers, replicates, and replicate sets on each of the servers within the domain.

Syntax:

```
▶▶ onstat -g cat ◀◀
```

If a replicated table is undergoing an alter operation, the **onstat -g cat** command shows that it is in alter mode. For example, use this command to determine:

- How many servers and how many replicates are configured
- Which table matches a given replicate
- Whether a server is a root or leaf server
- The current bitmap mask for a given server. You can use the bitmap mask with the output from the **onstat -g rqm** command to determine which server Enterprise Replication is waiting on for an acknowledgment.

The **onstat -g cat** command has the following formats:

```
onstat -g cat  
onstat -g cat replname  
onstat -g cat scope
```

The following table describes these formats.

Modifier	Description
<i>replname</i>	Specify the name of a replicate
<i>scope</i>	Specify one of the following values: <ul style="list-style-type: none">servers : Displays information only about serversrepls : Displays information only about replicatesfull : Displays expanded information for both replicate servers and replicates

Example output

This sample output from the **onstat -g cat repls** command shows that the table **tab** is in alter mode. The replicate **rep1** is defined on this table, its replicate ID is 6553601. For more information on the replicate attributes that this command

displays, see the *IBM Informix Enterprise Replication Guide*.

```
GLOBAL-CATALOG CACHE STATISTICS
REPLICATES
-----
Parsed statements:
  Id 6553601 table tab
  Id 6553602 table tab12
Inuse databases: test(2)
  Name: rep1, Id: 6553601 State: ACTIVE Flags: 0x800000 ALTERMODE
    use 0 lastexec Wed Dec 31 18:00:00 1969
    Local Participant: test:nagaraju.tab
    Attributes: TXN scope, Enable ATS, Enable RIS, all columns
      sent in updates
    Conflict resolution: [TIMESTAMP]
    Column Mapping: ON, columns INORDER, offset 8, uncomp_len 12
    Column Name Verification: ON
    No Replicated UDT Columns
  Name: rep12, Id: 6553602 State: ACTIVE Flags: 0x800000 use 0
    lastexec Wed Dec 31 18:00:00 1969
    Local Participant: test:nagaraju.tab12
    Attributes: TXN scope, Enable ATS, Enable RIS, all columns
      sent in updates
    Conflict resolution: [TIMESTAMP]
    Column Mapping: ON, columns INORDER, offset 8, uncomp_len 2064
    Column Name Verification: ON
    No Replicated UDT Columns
```

Figure 21-20. `onstat -g cat repls` command output

onstat -g cdr command: Print ER statistics

Use the `onstat -g cdr` command to display the output for all of the Enterprise Replication statistics commands.

Syntax:

```
▶▶ onstat -g cdr ▶▶
```

The output of the `onstat -g cdr` command is a combination of the following Enterprise Replication `onstat` command outputs:

- `onstat -g cat`
- `onstat -g grp`
- `onstat -g que`
- `onstat -g rqm`
- `onstat -g nif all`
- `onstat -g rcv`
- `onstat -g dss`
- `onstat -g dtc`
- `onstat -g rep`

For examples and descriptions of the output, refer to the following topics about the commands that compose the `onstat -g cdr` output:

- “`onstat -g cat` command: Print ER global catalog information” on page 21-57
- “`onstat -g grp` command: Print ER grouper statistics” on page 21-91
- “`onstat -g que` command: Prints ER queue statistics” on page 21-140

- “**onstat -g rqm** command: Print low-level queue statistics” on page 21-148
- “**onstat -g nif** command: Print statistics about the network interface” on page 21-120
- “**onstat -g rcv** command: Print ER receive manager statistics” on page 21-144
- “**onstat -g dss** command: Print ER environment data” on page 21-84
- “**onstat -g dtc** command: Print delete table cleaner statistics” on page 21-85
- “**onstat -g rep** command: Print ER schedule manager events” on page 21-148

onstat -g cdr config command: Print ER settings

Use the **onstat -g cdr config** command to display the settings of Enterprise Replication configuration parameters and environment variables that can be set with the CDR_ENV configuration parameter.

Syntax:

```

▶▶ onstat -g cdr config
┌───────────────────────────────────────────────────────────────────────────────────┐
│ long                                                                              │
│ parameter_name                                                                    │
│ parameter_name long                                                                │
│ CDR_ENV                                                                            │
│ CDR_ENV long                                                                      │
│ CDR_ENV variable_name                                                            │
│ CDR_ENV variable_name long                                                       │
└───────────────────────────────────────────────────────────────────────────────────┘

```

This command has the following formats:

```

onstat -g cdr config
onstat -g cdr config long
onstat -g cdr config parameter_name
onstat -g cdr config parameter_name long
onstat -g cdr config CDR_ENV
onstat -g cdr config CDR_ENV long
onstat -g cdr config CDR_ENV variable_name
onstat -g cdr config CDR_ENV variable_name long

```

The **long** option prints additional information about settings that can be useful for IBM Support.

The following table describes *parameter_name* and *variable_name*.

Modifier	Description
<i>parameter_name</i>	The name of an Enterprise Replication configuration parameter
<i>variable_name</i>	The name of an Enterprise Replication environment variable

If you use **onstat -g cdr config** without any options, the settings of all Enterprise Replication configuration parameters and environment variables are included in the output. If you specify the CDR_ENV configuration parameter without an environment variable name, all Enterprise Replication environment variables are included in the output.

Example output

The following sample output of the **onstat -g cdr config ENCRYPT_CDR** command shows the setting of the ENCRYPT_CDR configuration parameter:

```

onstat -g cdr config ENCRYPT_CDR
ENCRYPT_CDR configuration setting:          0

```

The following sample output of the **onstat -g cdr config CDR_ENV** command shows the settings of all Enterprise Replication environment variables:

```

onstat -g cdr config CDR_ENV

CDR_ENV environment variable settings:
  CDR_LOGDELTA:
    CDR_LOGDELTA configuration setting:      0
  CDR_PERFLOG:
    CDR_PERFLOG configuration setting:       0
  CDR_ROUTER:
    CDR_ROUTER configuration setting:        0
  CDR_RMSCALEFACT:
    CDR_RMSCALEFACT configuration setting:   0
  CDRSITES_731:
    CDRSITES_731 configuration setting:     [None configured]
  CDRSITES_92X:
    CDRSITES_92X configuration setting:     [None configured]
  CDRSITES_10X:
    CDRSITES_10X configuration setting:     [None configured]

```

The following sample output of the **onstat -g cdr config** command shows the settings of all Enterprise Replication configuration parameters and CDR_ENV environment variables:

```

onstat -g cdr config

CDR_DBSPACE:
  CDR_DBSPACE configuration setting:        rootdbs
CDR_DSLOCKWAIT:
  CDR_DSLOCKWAIT configuration setting:     5
CDR_EVALTHREADS:
  CDR_EVALTHREADS configuration setting:    1, 2
CDR_MAX_DYNAMIC_LOGS:
  CDR_MAX_DYNAMIC_LOGS configuration setting: 0
CDR_NIFCOMPRESS:
  CDR_NIFCOMPRESS configuration setting:    0
CDR_QDATA_SBSpace:
  CDR_QDATA_SBSpace configuration setting:  cdrsbsp
CDR_QHDR_DBSPACE:
  CDR_QHDR_DBSPACE configuration setting:   rootdbs
CDR_QUEUEMEM:
  CDR_QUEUEMEM configuration setting:      4096
CDR_SERIAL:
  CDR_SERIAL configuration setting:        0, 0
CDR_SUPPRESS_ATSRISWARN:
  CDR_SUPPRESS_ATSRISWARN configuration setting: [None suppressed]
ENCRYPT_CDR:
  ENCRYPT_CDR configuration setting:        0
ENCRYPT_CIPHERS:
  ENCRYPT_CIPHERS configuration setting:    [None configured]
ENCRYPT_MAC:
  ENCRYPT_MAC configuration setting:       [None configured]
ENCRYPT_MACFILE:
  ENCRYPT_MACFILE configuration setting:    [None configured]
ENCRYPT_SWITCH:
  ENCRYPT_SWITCH configuration setting:     0,0
CDR_ENV environment variable settings:
  CDR_LOGDELTA:
    CDR_LOGDELTA configuration setting:    0
  CDR_PERFLOG:
    CDR_PERFLOG configuration setting:     0
  CDR_ROUTER:

```

```

CDR_ROUTER configuration setting:          0
CDR_RMSCALEFACT:
  CDR_RMSCALEFACT configuration setting:    0
CDRSITES_731:
  CDRSITES_731 configuration setting:       [None configured]
CDRSITES_92X:
  CDRSITES_92X configuration setting:       [None configured]
CDRSITES_10X:
  CDRSITES_10X configuration setting:       [None configured]

```

onstat -g ckp command: Print checkpoint history and configuration recommendations

Use the **onstat -g ckp** command to print checkpoint history and display configuration recommendations if a suboptimal configuration is detected.

Syntax:

```
▶▶ onstat -g ckp ◀◀
```

Example output

Auto Checkpoints=On RTO_SERVER_RESTART=60 seconds Estimated recovery time 7 seconds											
											Critical Sections
Interval	Clock	Trigger	LSN	Total Time	Flush Time	Block Time	# Waits	Ckpt Time	Wait Time	Long Time	#Dirty Buffers
1	18:41:36	Startup	1:f8	0.0	0.0	0.0	0	0.0	0.0	0.0	4
2	18:41:49	Admin	1:11c12cc	0.3	0.2	0.0	1	0.0	0.0	0.0	2884
3	18:42:21	Llog	8:188	2.3	2.0	2.0	1	0.0	2.0	2.0	14438
4	18:42:44*	User	10:19c018	0.0	0.0	0.0	1	0.0	0.0	0.0	39
5	18:46:21	RTO	13:188	54.8	54.2	0.0	30	0.6	0.4	0.6	68232
Physical Log											
Dskflu /Sec	Total Pages	Avg /Sec	Logical Log								
4	3	0	Total Pages	Avg /Sec							
2884	1966	163	4549	379							
7388	318	10	65442	2181							
39	536	21	20412	816							
1259	210757	1033	150118	735							
Max Plog pages/sec	Max Llog pages/sec	Max Dskflush Time	Avg Dskflush pages/sec	Avg Dirty pages/sec	Blocked Time						
8796	6581	54	43975	2314	0						

Figure 21-21. **onstat -g ckp** command output

Output description

Auto Checkpoints

Indicates if the `AUTO_CKPTS` configuration parameter is on or off

RTO_SERVER_RESTART

Displays the RTO time in seconds. Zero (0) means that RTO is off.

Estimated recovery time ## seconds

Indicates the estimated recovery time if the data server stops responding. This value only appears if `RTO_SERVER_RESTART` is active.

Interval

Checkpoint interval ID

Clock Time

Clock time when checkpoint occurred.

Trigger

Event that triggered the checkpoint. An asterisk (*) indicates that the checkpoint requested was a transaction-blocking checkpoint.

Trigger name	Description
Admin	Administrator related tasks. For example: <ul style="list-style-type: none"> • Create, drop, or rename a dbspace • Add or drop a chunk • Add or drop a log file • Change physical log size or location • After "shrink" operation on partition • Turn on or off mirroring
Backup	Backup related operations. For example: <ul style="list-style-type: none"> • Fake backup • Start of an archive • After the completion of a physical restore
CDR	ER subsystem is started for the first time, or is restarted after all of the replication participants were removed.
CKPTINTVL	When the checkpoint interval expires. The checkpoint interval is the value specified for the CKPTINTVL parameter in the ONCONFIG file.
Conv/Rev	Conversion reversion checkpoint. After the check phase of convert and before the actual conversion of disk structures. After the reversion is completed also triggers a checkpoint.
HA	High availability. For example: <ul style="list-style-type: none"> • A new RSS or SDS node is added to a High Availability cluster • A secondary server is promoted to a primary server • The physical log file is low on a secondary server
HDR	High-Availability Data Replication. For example: <ul style="list-style-type: none"> • The mode of the server is changed • The start of the first transfer after HDR is setup • There is the potential for a physical log overflow on primary or secondary servers
Lightscan	Before the look aside is turned off on partitions.
Llog	Running out of logical log resources.

Trigger name	Description
LongTX	Long Transaction. If a long transaction has been found but not stopped, a checkpoint is initiated to stop the transaction. During rollback, a checkpoint is initiated in the rollback phase if a checkpoint has not already happened after long transaction has been aborted.
Misc	Miscellaneous events. For example: <ul style="list-style-type: none"> • A dbspace or chunk is being brought down because of I/O errors • During rollback when the addition of the chunk is being undone. For example, when removing the chunk.
Pload	When the High-Performance Loader starts in the Express mode.
Plog	Physical log has one of the following conditions: <ul style="list-style-type: none"> • Physical log is 75% full • The amount of physical log used plus the number of dirty partitions is more than 90% of physical log size
Restore Pt	Restore Point. Checkpoints at the start and end of a restore point. The restore point is (used by conversion guard) CONVERSION_GUARD configuration parameter is enabled and a temporary directory is specified in the RESTORE_POINT_DIR configuration parameter.
Recovery	During a restore, at the start of a fast recovery.
Reorg	At the start of online index build.
RTO	Maintaining the Recovery Time Objective (RTO) policy. During normal operations, when the restart time after a crash might exceed the value set for the RTO_SERVER_RESTART configuration parameter.
Stamp Wrap	Checkpoint timestamp. If the new checkpoint timestamp appears to be before the last written checkpoint, then the timestamp is advanced out of interval between checkpoints. Another checkpoint is triggered.
Startup	At the startup of the database server.
Uncompress	Uncompress commands that are issued on a table or partition. This applies only for checkpoints on tables or databases that are not logged.
User	A checkpoint request is submitted by the user.

LSN Logical log position where checkpoint is recorded

Total Time

Total checkpoint duration, in seconds, from request time to checkpoint completion

Flush Time

Time, in seconds, to flush bufferpools

Block Time

Time a transaction was blocked, in seconds, by a checkpoint that was triggered by a scarcity of some needed resource. For example, running out of physical log, or wrap-around of the logical log.

Waits

Number of transactions blocked waiting for checkpoint

Ckpt Time

Time, in seconds, for all transactions to recognize a requested checkpoint

Wait Time

Average time, in seconds, that transactions waited for checkpoint

Long Time

Longest amount of time, in seconds, a transaction waited for checkpoint

Dirty Buffers

Number of dirty buffers flushed to disk during checkpoint

Dskflu/sec

Number of buffers flushed per second

Physical Log Total Pages

Total number of pages physically logged during checkpoint interval

Physical Log Avg/Sec

Average rate of physical log activity during checkpoint interval

Logical Log Total Pages

Total number of pages logically logged during checkpoint interval

Logical Log Avg/Sec

Average rate of logical log activity during checkpoint interval

Max Plog pages/sec

Maximum rate of physical log activity during checkpoint interval

Max Llog pages/sec

Maximum rate of logical log activity during checkpoint interval

Max Dskflush Time

Maximum time, in seconds, to flush bufferpools to disk

Avg Dskflush pages/sec

Average rate bufferpools are flushed to disk

Avg Dirty pages/sec

Average rate of dirty pages between checkpoints

Blocked Time

Longest blocked time, in seconds, since the database server was last started

Performance advisory messages

If the Informix data server detects a configuration that is less than optimal, a performance advisory message with tuning recommendations appears below the

checkpoint history. This performance advisory message also appears in the message log. Following are examples of performance advisory messages:

Physical log is too small for bufferpool size. System performance may be less than optimal.
Increase physical log size to at least %ldKb

Physical log is too small for optimal performance.
Increase the physical log size to at least \$ldKb.

Logical log space is too small for optimal performance.
Increase the total size of the logical log space to at least %ld Kb.

Transaction blocking has taken place. The physical log is too small.
Please increase the size of the physical log to %ldKb

Transaction blocking has taken place. The logical log space is too small.
Please increase the size of the logical log space to %ldKb

Related reference:

“sysckptinfo” on page 2-10

onstat -g cluster command: Print high-availability cluster information

Use the **onstat -g cluster** command to display information about the servers in a high-availability cluster environment.

Syntax:

```
▶▶ onstat -g cluster [verbose] ▶▶
```

The **onstat -g cluster** command combines the functionality of **onstat -g dri**, **onstat -g sds**, and **onstat -g rss**. The output of the **onstat -g cluster** command differs slightly depending on whether the command is run on the primary server or on one of the secondary servers.

Example output (primary server)

Following is sample output from the **onstat -g cluster** command. The sample shows output when the command is run on the primary server.

```
Primary Server: serv1
Current Log Page: 16,476
Index page logging status: Enabled
Index page logging was enabled at: 2010/01/11 14:05:17

Server ACKed Log Supports Status
(log, page) Updates
serv2 16,476 Yes SYNC(SDS), Connected, Active
serv3 16,476 Yes ASYNC(HDR), Connected, On
serv4 16,476 Yes ASYNC(RSS), Connected, Active
```

Figure 21-22. **onstat -g cluster** command output (run on the primary server)

Output description (primary server)

Primary server

The name assigned to the primary server.

Current log page

The log ID and page number of the current log page.

Index page logging status

Indicates whether index page logging is enabled or disabled.

Index page logging was enabled at

The date and time that index page logging was enabled.

Server The name of the secondary server.

ACKed Log (log, page)

The log ID and page number of the last acknowledged log transmission.

Supports Updates

Displays whether client applications can perform update, insert, and delete operations on the secondary server (as specified by the `UPDATABLE_SECONDARY` configuration parameter).

Status Displays the connection status of the secondary server

Example output (primary server, verbose output)

Following is sample output from the `onstat -g cluster verbose` command. The sample shows output when the command is run on the primary server with the verbose option.

```
Primary Server: serv1
Current Log Page: 16,479
Index page logging status: Enabled
Index page logging was enabled at: 2010/01/11 14:05:17
```

```
-----
server name: serv3
type: ASYNC (HDR)
control block: 0x4b673018
server status: On
connection status: Connected
Last log page sent (log id, page): 16,479
Last log page acked (log id, page): 16,479
Approximate log page backlog: 0
SDS cycle not used
Delayed Apply Not Used
Stop Apply Not Used
Time of last ack: 2010/01/15 14:09:12
Supports Updates: Yes
```

```
-----
server name: serv2
type: SYNC (SDS)
control block: 0x4c2de0b8
server status: Active
connection status: Connected
Last log page sent (log id, page): 16,479
Last log page acked (log id, page): 16,479
Approximate log page backlog: 0
SDS cycle current: 20 ACKed: 20
Delayed Apply Not Used
Stop Apply Not Used
Time of last ack: 2010/01/15 14:09:13
Supports Updates: Yes
```

Figure 21-23. `onstat -g cluster verbose` command output (run on the primary server)

Output description (primary server, verbose output)

Primary server

The name of the primary server

Current log page

The log ID and page number of the current log page.

Index page logging status

Indicates whether index page logging is enabled or disabled.

Index page logging was enabled at

The date and time that index page logging was enabled.

Server name

The name of the secondary server.

type

Displays whether the secondary server is connected synchronously (SYNC) or asynchronously (ASYNC). Also displays the type of secondary server: HDR, SDS, or RSS.

control block

The in-memory address of the thread control block.

server status

Displays the current status of the secondary server.

connection status

Displays the current network connection status of the secondary server.

Last log page sent (log id, page)

The log ID and page number of the most recent log page sent by the primary server to the secondary server.

Last log page acked (log id, page)

The log ID and page number of the most recent log page the secondary server acknowledged.

Approximate log page backlog

Indicates the approximate number of log pages that have yet to be processed by the secondary server.

SDS cycle

Indicates the cycle number to which the primary server has advanced and which the shared disk secondary server has acknowledged. Used internally by IBM support to monitor coordination of the primary server with the secondary server.

Delayed Apply

Indicates whether the secondary server waits for a specified amount of time before applying logs (as specified by the DELAY_APPLY configuration parameter).

Stop Apply

Indicates whether the secondary server has stopped applying log files received from the primary server (as specified by the STOP_APPLY configuration parameter).

Time of last ack

The date and time of the last acknowledged log.

Supports Updates

Displays whether client applications can perform update, insert, and delete operations on the secondary server (as specified by the UPDATABLE_SECONDARY configuration parameter).

Example output (secondary server)

Following is sample output from the **onstat -g cluster** command. The sample shows output when the command is run on a secondary server.

```
Primary Server: serv1
Index page logging status: Enabled
Index page logging was enabled at: 2010/01/11 14:05:17

Server ACKed Log   Supports   Status
   (log, page) Updates
serv2 16,479      Yes       SYNC(SDS),Connected,Active
```

Figure 21-24. **onstat -g cluster** command output (run on the secondary server)

Output description (secondary server)

Primary server

The name of the primary server

Index page logging status

Indicates whether index page logging is enabled or disabled.

Index page logging was enabled at

The date and time that index page logging was enabled.

Server The name of the secondary server.

ACKed Log (log, page)

The log ID and page number of the last acknowledged log.

Supports Updates

Displays whether client applications can perform update, insert, and delete operations on the secondary server (as specified by the `UPDATABLE_SECONDARY` configuration parameter).

Status Displays the connection status of the secondary server.

Related reference:

“`DELAY_APPLY` Configuration Parameter” on page 1-53

“`STOP_APPLY` configuration parameter” on page 1-154

“`UPDATABLE_SECONDARY` Configuration Parameter” on page 1-162

onstat -g cmsm command: Print Connection Manager information

Use the `onstat -g cmsm` command to display Connection Manager information, such as the number of Connection Manager daemons attached to the current database instance, as well as the number of connections each daemon has processed.

Syntax:

```
▶▶ onstat -g cmsm cm_name ▶▶
```

The optional `cm_name` parameter is used to specify the name of a Connection Manager instance. Omitting the `cm_name` parameter displays information about all active Connection Manager instances.

Example output

```
Connection Manager Name: cm1      Hostname: apollo11
Cluster c1
  SLA          Connections  Service/Protocol  Rule
  oltp1        3           9696/onsoctcp    DBSERVERS=primary

Failover Configuration:
Connection Manager name      Rule      Timeout  State
cm1                          SDS+HDR+RSS      0  Active Arbitrator, Primary is up

Grig grid1
  SLA          Connections  Service/Protocol  Rule
  gridany      3           9400/onsoctcp    DBSERVERS=ANY
  grid1_avail  30          9410/onsoctcp    DBSERVERS=(ny1,ny2,ny3),\
                                     (ca1,ca2,ca3)
```

Figure 21-25. `onstat -g cmsm` command output with the Connection Manager managing one cluster and one grid

Output description

The output of the `onstat -g cmsm` command is divided into several sections. The first section displays the Connection Manager instance name and host name. The rest of the sections display service level agreements and failover configurations for each connection unit. The example output shows two Connection Manager instances named `dwk_ucm1` and `dwk_ucm2`.

Connection Manager Name

The name of the Connection Manager instance.

Hostname

The name of the host.

SLA The name of the service level agreement.

Connections

The number of connections that are processed with the service level agreement.

Service/Protocol

The port number or service name associated with the Service Level Agreement, followed by the protocol (onsoctcp, drsoctcp, onsocssl, drsocssl).

Rule The service level agreement definition which can include server types (Primary, SDS, RSS, HDR) or server names.

Failover Configuration

Connection Manager Name

The name of the Connection Manager instance.

Rule The failover configuration.

Timeout

The timeout value, in seconds, for the failover configuration.

State An indicator of the status of the primary server. Also indicates the Connection Manager instance serving as the failover arbitrator.

onstat -g con command: Print condition and thread information

Use the **onstat -g con** command to display information about conditions and the threads that are waiting for the conditions.

Syntax:

▶▶ onstat -g con ◀◀

Example output

```
Conditions with waiters:
cid      addr          name          waiter  waittime
271      c63d930      netnorm      1511    6550
```

Figure 21-26. **onstat -g con** command output

Output description

cid Condition identifier

addr Condition control block address

name Name of condition the thread is waiting on

waiter ID of thread waiting on condition

waittime

Time, in seconds, thread has been waiting on this condition

onstat -g cpu: Print runtime statistics

Use the **onstat -g cpu** command to display information about runtime statistics for each thread that is running in the server.

Syntax:

▶▶ onstat -g cpu ◀◀

Example output

```
onstat -g cpu
```

```
Thread CPU Info:
```

tid	name	vp	Last Run	CPU Time	#scheds	status
2	lio vp 0	3lio*	07/18 08:35:35	0.0000	1	IO Idle
3	pio vp 0	4pio*	07/18 08:35:36	0.0102	2	IO Idle
4	aio vp 0	5aio*	07/18 08:35:47	0.6876	68	IO Idle
5	msc vp 0	6msc*	07/18 11:47:24	0.0935	14	IO Idle
6	main_loop()	1cpu*	07/18 15:02:43	2.9365	23350	sleeping secs: 1
7	soctcpoll	7soc*	07/18 08:35:40	0.1150	1	running
8	soctcpio	8soc*	07/18 08:35:40	0.0037	1	running
9	soctcplst	1cpu*	07/18 11:47:24	0.1106	10	sleeping forever
10	soctcplst	1cpu*	07/18 08:35:40	0.0103	6	sleeping forever
11	flush_sub(0)	1cpu*	07/18 15:02:43	0.0403	23252	sleeping secs: 1
12	flush_sub(1)	1cpu*	07/18 15:02:43	0.0423	23169	sleeping secs: 1
13	flush_sub(2)	1cpu*	07/18 15:02:43	0.0470	23169	sleeping secs: 1
14	flush_sub(3)	1cpu*	07/18 15:02:43	0.0407	23169	sleeping secs: 1
15	flush_sub(4)	1cpu*	07/18 15:02:43	0.0307	23169	sleeping secs: 1
16	flush_sub(5)	1cpu*	07/18 15:02:43	0.0323	23169	sleeping secs: 1
17	flush_sub(6)	1cpu*	07/18 15:02:43	0.0299	23169	sleeping secs: 1
18	flush_sub(7)	1cpu*	07/18 15:02:43	0.0314	23169	sleeping secs: 1
19	kaio	1cpu*	07/18 14:56:42	1.4560	2375587	IO Idle
20	aslogflush	1cpu*	07/18 15:02:43	0.0657	23166	sleeping secs: 1
21	btscanner_0	1cpu*	07/18 15:00:53	0.0484	784	sleeping secs: 61
37	onmode_mon	1cpu*	07/18 15:02:43	0.3467	23165	sleeping secs: 1
43	dbScheduler	1cpu*	07/18 14:58:14	1.6613	320	sleeping secs: 31
44	dbWorker1	1cpu*	07/18 13:48:10	0.4264	399	sleeping forever
45	dbWorker2	1cpu*	07/18 14:48:11	1.9346	2936	sleeping forever
94	bf_priosweep()	1cpu*	07/18 15:01:42	0.0431	77	cond wait bp_cond

Figure 21-27. `onstat -g cpu` command output

Output description

tid The ID of the thread

name The name of the thread

vp The ID of the virtual processor in which the thread is running

Last Run

The timestamp when the thread last ran

CPU Time

The time taken until now by the thread

#scheds

The number of times the thread was scheduled to run

status The status of the thread. Possible status values are:

- cond wait
- IO Idle
- join wait
- mutex wait
- ready
- sleeping
- terminated
- running
- yield

onstat -g dbc command: Print dbScheduler and dbWorker thread statistics

Use the **onstat -g dbc** command to display statistics about the Scheduler tasks that are currently running, which are handled by dbWorker threads, or scheduled to be run, which are handled by the dbScheduler thread.

Syntax:

```
▶▶ onstat -g dbc ◀◀
```

Example output

```
Worker Thread(0) 46fa6f10
=====
Task: 47430c18
Task Name: mon_config_startup
Task ID: 3
Task Type: STARTUP SENSOR
Last Error
  Number -310
  Message Table (informix.mon_onconfig) already exists in database.
  Time 09/11/2007 11:41
  Task Name mon_config_startup

Task Execution: onconfig_save_diffs

WORKER PROFILE
  Total Jobs Executed 10
  Sensors Executed 8
  Tasks Executed 2
  Purge Requests 8
  Rows Purged 0

Worker Thread(1) 46fa6f80
=====
Task: 4729fc18
Task Name: mon_sysenv
Task ID: 4
Task Type: STARTUP SENSOR
Task Execution: insert into mon_sysenv select 1, env_name, env_value FROM
  sysmaster:sysenv

WORKER PROFILE
  Total Jobs Executed 3
  Sensors Executed 2
  Tasks Executed 1
  Purge Requests 2
  Rows Purged 0

Scheduler Thread 46fa6f80
=====
Run Queue
  Empty
Run Queue Size 0
Next Task 7
Next Task Waittime 57
```

Figure 21-28. onstat -g dbc command output

Output description

Worker Thread

Address of the worker thread in shared memory

Task Name of the last executed task

Task ID

The task ID from the `tk_id` column in the `sysadmin:ph_task` table for this task

Task Type

Type of the task

Last Error

Error number, error message, time (in seconds), and task name from the last error the dbWorker thread encountered. It could be from the previously executed task or from a task executed days ago.

Task Execution

SQL statement or SPL procedure or routine executed as part of the task

WORKER PROFILE

The dbWorker thread profile data shows the total jobs executed, number of sensors executed, number of tasks executed, number of purge requests, and the number of rows purged from the result tables for all sensors executed by this dbWorker thread.

Scheduler Thread

Address of the scheduler thread in shared memory

Run Queue

The task ID for the next scheduled task. If no task is scheduled, the value is Empty.

Run Queue Size

The number of tasks that are waiting to be executed by the dbWorker thread

Next Task

The task ID of the next task that will be scheduled to be executed

Next Task Waittime

The number of seconds before the Next Task will be scheduled for execution

Related reference:

 [Monitor the scheduler \(Administrator's Guide\)](#)

“scheduler argument: Stop or start the scheduler (SQL administration API)” on page 22-102

onstat -g ddr command: Print ER database log reader status

Use the `onstat -g ddr` command to display information about the status of the Enterprise Replication database log reader.

Syntax:

```
▶▶ onstat -g ddr ▶▶
```

The `ddr`, or `ddr_snoopy` option, is an internal component of Enterprise Replication that reads the log buffers and passes information to the grouper component.

You can use the information from the **onstat -g ddr** command to monitor the *replay position* in the log file and ensure that the replay position is never overwritten, which can cause loss of data. The replay position is the point from where, if a system failure occurs, Enterprise Replication starts re-reading the log information into the log update buffers. All the transactions generated before this position at all of the target servers have been applied by Enterprise Replication or safely stored in the stable queue space. As messages are acknowledged or stored in the stable queue, the replay position should advance. If you notice that replay position is not advancing, this can mean that the stable queue is full or a remote server is down.

The output from the **onstat -g ddr** command shows you a snapshot of the replay position, the *snoopy position*, and the *current position*. The snoopy position identifies the position of the **ddr_snoopy** thread in the logical logs. The snoopy position is the read position. The **ddr_snoopy** thread has read the log records up until this point. The current position is the position where the server has written its last logical log record.

If log reading is blocked, data might not be replicated until the problem is resolved. If the block is not resolved, the database server might overwrite the read (**ddr_snoopy**) position, which means that data will not be replicated. If this occurs, you must manually resynchronize the source and target databases.

You can enable dynamic log creation by setting the `CDR_MAX_DYNAMIC_LOGS` configuration parameter in the `ONCONFIG` file. If the current position reaches the log needs position, instead of going into a blocked state, Enterprise Replication automatically adds another log file. If this option is set, the **onstat -g ddr** command displays information about the number of dynamic log requests made. For more information, see the *IBM Informix Enterprise Replication Guide*.

Example output

The following sample output from the **onstat -g ddr** command shows the replay position, the snoopy position, and the current position highlighted.

```

DDR -- Running
# Event Snoopy   Snoopy  Replay  Replay  Current  Current
Buffers ID    Position ID    Position ID    Position
528      24    165018  24     6a018   24     166000

Log Pages Snooped:      From      From      Tossed
                       Cache     Disk     (LBC full)
                       247     111      0

Total dynamic log requests: 0
DDR events queue

Type  TX id  Partnum  Row id

```

Figure 21-29. **onstat -g ddr** command output

onstat -g defragment command: Print defragment partition extents

Use the **onstat -g defragment** command to display information about the active requests to defragment partition extents.

Syntax:

►► onstat -g defragment ◀◀

Example output

Defrag info							
id	table name	tid	dbnum	partnum	status	substatus	errnum
15	stores_demo:informix.stdtab2	49	2	2097155	SEARCHING_FOR_EXTENT	0	0

Figure 21-30. onstat -g defragment command output

Note: This command displays information about defragment requests that are active. If there are no active defragment requests, only the column headings are returned.

Output description

id The ID of the defragment request.

table name

The fully-qualified name of the table that is being defragmented.

tid The thread ID.

dbnum

The dbspace number that is being defragmented.

partnum

The partition number that is being defragmented.

status

- SEARCHING_FOR_EXTENT
- MERGING_EXTENTS
- DEFRAG_COMPLETED
- DEFRAG_FAILED

substatus

The detailed status number, if any.

errnum

The last error number returned from the defragmentation request.

onstat -g dic command: Print table information

Use the **onstat -g dic** command to display a line of information about each table that is cached in the shared-memory dictionary. If you specify a table name, this command prints internal SQL information about that particular table.

Syntax:

►► onstat -g dic ◀◀

Example output

```

Dictionary Cache: Number of lists: 31, Maximum list size: 10
list# size refcnt dirty? heapptr table name
-----
  1    3     1    no    14b5d890 wbe@oninit_shm:informix.t0010url
      1     1    no    14cbb820 wbe@oninit_shm:informix.t9051themeval
      0     0    no    14b63c20 wbe@oninit_shm:informix.t0060hits
  2    2     0    no    14b97420 wbe@oninit_shm:informix.t0120import
      1     1    no    14b6c820 wbe@oninit_shm:informix.t9110domain
  3    3     0    no    14bce020 wbe@oninit_shm:informix.t0150url
      0     0    no    14d3d820 contact@oninit_shm:informix.wbtags
      0     0    no    14c87420 wbe@oninit_shm:informix.wbtags
  4    1     0    no    14b7a420 drug@oninit_shm:abcdef.product ..
Total number of dictionary entries: 36

```

Figure 21-31. `onstat -g dic` command output

Output description

list# Data dictionary hash chain ID

size Number of entries in this hash

refcnt Number of SQL statements currently referencing one of the cache entries.

dirty? Whether the entry has been modified since last written to disk.

heapptr

Address for the heap used to store this table

table name

Name of table in cache

For more information on the `onstat -g dic` command, see the *IBM Informix Performance Guide*.

onstat -g dis command: Print database server information

Use the `onstat -g dis` command to display a list of database servers, the status of each server, and information about each server, including the location of the `INFORMIXDIR` directory, `sqlhosts` file, and `ONCONFIG` file. You can use this command in any database server mode, including offline.

Syntax:

▶▶—onstat— -g—dis—▶▶

Example output

```

There are 2 servers found
Server       : ol_tuxedo
Server Number : 53
Server Type  : IDS
Server Status : Up
Server Version: IBM Informix Version 11.50.UC1
Shared Memory : 0xa000000
INFORMIXDIR  : /local1/engines/ol_tuxedo/dist
ONCONFIG     : /local1/engines/ol_tuxedo/dist/etc/onconfig.ol_tuxedo
SQLHOSTS     : /local1/engines/ol_tuxedo/dist/etc/sqlhosts
Host        : avocet

Server       : ol_9next
Server Number : 0
Server Type  : IDS
Server Status : Down
Server Version:
Shared Memory : 0
INFORMIXDIR  : /local1/engines/ol_9next/dist
ONCONFIG     :
SQLHOSTS     :
Host        :

```

Figure 21-32. `onstat -g dis` command output

Output description

Server Server name

Server Number
Number of the server.

Server Type
Type of server

Server Status
Up means that the server is online, Down means that the server is offline

Server Version
Version of the server

Shared Memory
Location of the shared memory address

INFORMIXDIR
Location of the `$INFORMIXDIR/` directory on UNIX and in the `%INFORMIXDIR%\` directory on Windows.

ONCONFIG
Location of the ONCONFIG file

SQLHOSTS
Location of the `sqlhosts` file

Host Host name of the server

onstat -g dsk command: Print the progress of the currently running compression operation

Use the `onstat -g dsk` command to print information that shows the progress of currently running compression operations, such as compress, repack, and shrink.

Syntax:

```
▶▶ onstat -g dsk ◀◀
```

Example output

Partnum	OP	Rows Processed	Cur Page	Approx Prog	Duration	Approx Remaining	Table
0x00100196	COMPRESS	63253	3515	75%	00:00:03	00:00:01	footab

Figure 21-33. `onstat -g dsk` command output for a compress operation

Partnum	OP	Rows Processed	Cur Page	Approx Prog	Duration	Approx Remaining	Table
0x00100196	REPACK	22900	4285	28%	00:00:01	00:00:02	footab

Figure 21-34. `onstat -g dsk` command output for a repack operation

Output description

partnum

Partition number of the table or fragment

OP Compression operation, such as compress, repack, or shrink.

Processed

Number of rows processed so far for the specified operation

Curr Page

The current page number that the server is operating on now

Approx Prog

Percentage of the total operation that has completed

Duration

The number of seconds that have elapsed since the operation started

Approx Remaining

The approximate time that remains before the operation is complete

Table Name of the table

onstat -g dll command: Print dynamic link library file list

Use the `onstat -g dll` command to display a list of and the status of dynamic link library (DLL) files that were loaded.

Syntax:

```
▶▶ onstat -g dll ◀◀
```

Example output

The output displays the names of the library files only one time each process group. The flags indicate if the library was loaded when the server was started.

addr	slot	vp	baseaddr	flags	filename
0x4af55310	15	1	0x2a985e3000	PM	/finance/jeffzhang/mylib.udr
0x4b6f2310		2	0x2a985e3000		
0x4b71b310		3	0x2a985e3000		
0x4c09f310	16	1	0x2a985e3000	M	/deptxyz/udrs/geodetic.bld
0x4c0c0310		2	0x2a985e3000		
0x4c0f1310		3	0x2a985e3000		
0x4c112310	17	1	0x7a138e9000		/home/informix/extend/blade.so
0x4c133310		2	0x3a421e1000		
0x4c133310		3	0x3a421e1000		

Figure 21-35. `onstat -g dll` command output

Output description

addr Address of the DLL file

slot Slot number entry in the library table

vp ID of the virtual processor

baseaddr
Base address of the shared library

flags

- M indicates that the thread calling the UDR can migrate from one CPU virtual processor to another CPU virtual processor.
- P indicates that the shared library was loaded when the database server was started.

filename
Name of the DLL file

onstat -g dmp command: Print raw memory

Use the `onstat -g dmp` command to display information about raw memory at a given address for a number of given bytes.

Syntax:

►► `onstat -g dmp address length` ◀◀

Each address and length must be within the allocated memory shown from `onstat -g seg` output. The address specified can be in decimal or hexadecimal format. Hexadecimal addresses must begin with `0x`. You can specify the address in decimal, but doing so requires converting the memory shown from `onstat -g seg` to decimal before using it as a command line argument.

Example output

```

%onstat -g dmp 0x700000011a19d48 100

address          bytes in mem
0700000011a19d48: 07000000 118e0fa8 07000000 11942b40 .....+@
0700000011a19d58: 07000000 10137120 00000000 00000000 .....q .....
0700000011a19d68: 00000000 00000000 00000000 00000000 .....
0700000011a19d78: 07000000 11a19d48 07000000 11a19d48 .....H .....H
0700000011a19d88: 00000000 00000000 00000000 00000000 .....
0700000011a19d98 *
0700000011a19da8: 00000000 ....

```

Figure 21-36. `onstat -g dmp` command output

Output description

address

Memory address of the raw memory.

bytes in mem

Hexadecimal and ASCII representations of the memory contents.

Output from the command is divided into three columns: memory address, hexadecimal values for the bytes in memory, and the ASCII representation of the bytes in memory. The bytes in memory (middle) section displays the first 16 bytes of memory starting at the address specified on the command line. The third column shows the ASCII representation of the hexadecimal data. Periods are displayed for all hexadecimal values that do not have an ASCII character equivalent. ASCII values are shown in order to make searching for plain text easier.

In the example output shown, the fifth line of data displays zeros and the sixth line contains an asterisk. The asterisk indicates an unknown number of repetitions of the previous line, which means that there is no more data after the fourth line.

`onstat -g dri` command: Print high-availability data replication information

Use the `onstat -g dri` command to print information about high-availability data replication statistics on the current server.

Use the `onstat -g dri ckpt` command to print information about nonblocking checkpoints in HDR servers.

Syntax:

```

▶▶ onstat -g dri [ckpt]

```

Example output

```

Data Replication:
Type           State           Paired server      Last DR CKPT (id/pg)  Supports Proxy Writes
primary        on              BB_1                554 / 558             Y

DRINTERVAL    30
DRTIMEOUT     30
DRAUTO        0
DRLOSTFOUND   /vobs/tristarm/sqlldist/etc/dr.lostfound
DRIDXAUTO     0
ENCRYPT_HDR    0
Backlog       0
Last Send     2011/12/04 00:40:32
Last Receive  2011/12/04 00:40:32
Last Ping     2011/12/04 00:40:18

```

Figure 21-37. **onstat -g dri** command output

```

Data Replication:
Type           State           Paired server      Last DR CKPT (id/pg)  Supports Proxy Writes
primary        on              BB_1                554 / 558             Y

DRINTERVAL    30
DRTIMEOUT     30
DRAUTO        0
DRLOSTFOUND   /vobs/tristarm/sqlldist/etc/dr.lostfound
DRIDXAUTO     0
ENCRYPT_HDR    0

DR Checkpoint processing:
Save State     N
Pages Saved    0
Save Area      none
Received log id, page  17,68
Saved log id, page    0,0
Drain log id, page    0,0
Processed log id, page 17,68
Pending checkpoints  0

```

Figure 21-38. **onstat -g dri ckpt** command output

Output description

Type Current type of server: primary, secondary, or standard

State on or off

Paired server

Name of the primary or secondary server that this server is paired with

Last DR CKPT

Last checkpoint ID and page

Supports Proxy Writes

Displays whether the server is currently configured to allow secondary server updates. **Y** = supports secondary server updates, **N** = does not support secondary server updates.

The second section lists the values of the following configuration parameters in the ONCONFIG file:

- DRINTERVAL
- DRTIMEOUT

- DRAUTO
- DRLOSTFOUND
- DRIDXAUTO
- ENCRYPT_HDR
- Backlog - Number of log pages in the HDR data replication buffer (not yet sent to the secondary server)
- Last Send - The time that the last message was sent to the peer node
- Last Receive - The time that the last message was received from the peer node
- Last Ping - The time of the last ping

The third section displays checkpoint processing statistics:

Save State

Displays **B** (for *buffering*) when the server is adding logs to the staging area, **D** (for *draining*) when the server is removing logs from the staging area, or **N** (for *normal*) when the server is operating normally, meaning that no logs are saved.

Pages Saved

Displays the number of log pages that have been saved in the staging area that have yet to be applied.

Save Area

Displays the location of the staged log files.

Received log id,page

Displays the last log ID and page received from the primary server.

Processed log id,page

Displays the last log ID and page that have been queued to the recovery pipeline.

Saved log id,page

Displays the last log ID and page that was stored in the staging area (if stage state is either **B** or **D**).

Drain log id,page

Displays the last log ID and page that have been removed from the staging area.

Pending checkpoints

Displays the number of checkpoints that have been staged but have not yet been applied.

Pending ckpt log id, page

Displays the position of any pending checkpoint records.

onstat -g dsc command: Print distribution cache information

Use the **onstat -g dsc** command to display information about distribution cache.

Syntax:

▶▶ onstat -g dsc ◀◀

Example output

```

Distribution Cache:
  Number of lists      : 31
  PC_POOLSIZe        : 50
  Number of entries   : 0
  Number of entries in use : 0
Distribution Cache Entries:
list# id ref_cnt  dropped?  heap_ptr      distribution name
-----
Distribution Cache is empty.

```

Figure 21-39. **onstat -g dsc** command output

Output description

The first section of output describes the distribution cache.

Number of lists

Number of lists in the distribution cache

PC_POOLSIZe

Number of entries that can be cached at one time

Number of entries

Number of entries in the distribution cache

Number of entries in use

Number of entries being used

The second section of output describes the distribution cache entries.

list# Distribution cache hash chain ID

id Number of hash entries

ref_cnt

Number of statements referencing a cache entry

dropped?

Whether this entry has been dropped since being added to the cache

heap_ptr

Heap address used to store this entry

distribution name

The name of the distribution in the cache

onstat -g dss command: Print ER environment data

Use the **onstat -g dss** command to print detailed statistical information about the activity of individual data sync threads in an Enterprise Replication environment.

Syntax:

```

▶▶ onstat -g dss [modifier]

```

The data sync thread applies the transaction on the target server. Statistics include the number of applied transactions and failures and when the last transaction from a source was applied.

The **onstat -g dss** command has the following formats:

```
onstat -g dss
onstat -g dss modifier
```

The following table describes the values for *modifier*.

Modifier	Action
UDR	Prints summary information about any UDR invocations by the data sync threads.
UDRx	Prints expanded information (including a summary of error information) about any UDR invocations by the data sync threads. The Proc id column lists the UDR procedure ID.

Example output

In the following example, only one data sync thread is currently processing the replicated data. It has applied a total of one replicated transaction and the transaction was applied at 2004/09/13 18:13:10. The Processed Time field shows the time when the last transaction was processed by this data sync thread.

```
DS thread statistic
cmtTime      Tx      Tx      Tx      Last Tx
Name         < local  Committed Aborted Processed  Processed Time
-----
CDRD_1          0          1          0          1 (1095117190) 2008/09/13 18:13:10
      Tables (0.0%):
      Databases: test
CDR_DSLOCKWAIT = 1
CDR_DSCLOSEINTERVAL = 60
```

Figure 21-40. `onstat -g dss` Output

onstat -g dtc command: Print delete table cleaner statistics

Use the `onstat -g dtc` command to display statistics about the delete table cleaner. The delete table cleaner removes rows from the delete table when the rows are not needed.

The `onstat -g dtc` command is used primarily as a debugging tool and most often by IBM Support.

Syntax:

```
▶▶ onstat -g dtc ◀◀
```

Example output

In the following example, the thread name of the delete table cleaner is **CDRDTCleaner**. The total number of rows deleted is **1**. The last activity on this thread occurred at 2010/09/13 18:47:19. The delete table for replicate **rep1** was last cleaned at 2010/09/13 18:28:25.

```

-- Delete Table Cleanup Status as of (1095119368) 2010/09/13 18:49:28
  thread          = 49 <CDRDTCleaner>
  rows deleted    = 1
  lock timeouts   = 0
  cleanup interval = 300
  list size       = 3
  last activity   = (1095119239) 2010/09/13 18:47:19
Id      Database      Last Cleanup Time
  Replicate      Server      Last Log Change
=====
000001  test              (1095118105) 2010/09/13 18:28:25
      repl          g_bombay      (1095118105) 2010 /09/13 18:28:25
      repl          g_delhi       (1095118105) 2010 /09/13 18:28:25
000002  test              <never cleaned>

```

Figure 21-41. `onstat -g dtc` command output

onstat -g env command: Print environment variable values

Use the `onstat -g env` command to display the values of the environment variables that the database server currently uses.

Syntax:

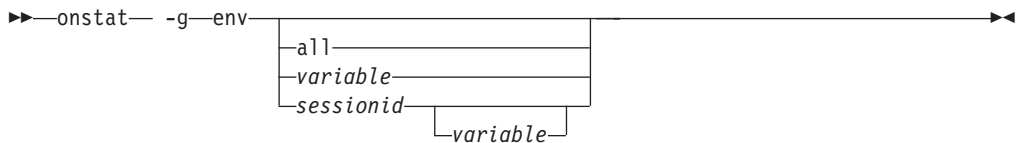

You can specify one of the following invocations.

Invocation	Explanation
<code>onstat -g env</code>	Displays the settings of environment variables when the database server was started Does not display environment variables that have not been set explicitly.
<code>onstat -g env all</code>	Displays the settings used by all sessions This display is the same as the output of <code>onstat -g env</code> and <code>onstat -g env sessionid</code> iteratively on all current sessions.
<code>onstat -g env variable</code>	Displays the default value of the specified environment variable This <i>variable</i> argument eliminates the need to pipe the output to <code>grep</code> (or some other utility) to locate an environment variable among many that might be set.
<code>onstat -g env sessionid</code>	Displays the settings that a specific session uses. This display includes the following values: <ul style="list-style-type: none"> Set in the environment of the session Assigned by the database server, as <code>onstat -g env</code> displays

Invocation	Explanation
<code>onstat -g env sessionid variable</code>	<p>Displays the value of the specified environment variable that the specified session uses</p> <p>The <i>sessionid</i> and <i>variable</i> arguments eliminate the need to pipe the output to grep (or some other utility) to locate an environment variable among many that might be set.</p>

The **onstat -g env** command displays the current setting of an environment variable and the complete list of values each time the variable was set in the environment. For example, if PDQPRIORITY is set to 10 in the `.informix.rc` file and set to 55 in the shell environment, **onstat -g env** command displays both values.

However, if you change the PDQPRIORITY with the **onmode -q pdqpriority sessionid** command, the **onstat -g env** command does not display the new value for the session. The **onstat -g env** command displays only the values of environment variables set in the environment. It does not display values modified while the session is running.

You might want to display the values of environment variables in the following situations:

- The database server instance has been up for months, and you cannot remember the setting of an environment variable (such as the server locale setting `SERVER_LOCALE`).
- You want to display the complete list of values for an environment variable to identify when an environment variable has been set in multiple places.
- Environment files on disk might have changed or been lost in the interim.
- A support engineer wants to know settings of specific environment variables.

Example output

The following figure shows the output for the **onstat -g env** command.

Variable	Value [values-list]
DBDATE	DMY4/
DBDELIMITER	
DBPATH	.
DBPRINT	lp -s
DBTEMP	/tmp
INFORMIXDIR	/build2/11.50/tristarm/sqldist [/build2/11.50/tristarm/sqldist] [/usr/informix]
INFORMIXSERVER	parata1150
INFORMIXTERM	termcap
LANG	C
LC_COLLATE	C
LC_CTYPE	C
LC_MONETARY	C
LC_NUMERIC	C
LC_TIME	C
LD_LIBRARY_PATH	/usr/openwin/lib:/lib:/usr/lib
LKNOTIFY	yes
LOCKDOWN	no
NODEFDAC	no
NON_M6_ATTRS_OK	1
PATH	/build2/11.50/tristarm/sqldist/bin:: /root/bin:/opt/SUNWspro/bin:/usr/ccs/bin: /usr/openwin/bin:/usr/sbin:/usr/bin:/usr /local/binSERVER_LOCALE en_US.819
SHELL	/bin/ksh
SINGLELEVEL	no
SUBQCACHESZ	10
TBCONFIG	onconfig
TERM	xterm [xterm] [dumb]
TERMCAP	/etc/termcap
TZ	GB

Figure 21-42. `onstat -g env` command output

onstat -g ffr command: Print free fragments

Use the `onstat -g ffr` command to display information about the free memory fragments for a specified session or shared-memory pool.

This command requires an additional argument to specify either a pool name or session ID whose memory pool information is to be displayed. Each session is allocated a memory pool with the same name as the session ID. Use the `onstat -g mem` command to identify the pool name and the `onstat -g ses` command to identify the session ID.

Syntax:

```

▶▶ onstat -g ffr pool name
sessionid

```

Example output

```
Free lists for pool name aio:
addr      size    idx
165dcfa0  96      10
1659cf68  152     17
165b2f20  224     26
165c7f20  224     26
1666ec38  968     79
149f2ba0  1120    84
```

Figure 21-43. `onstat -g ffr aio` command output

Output description

addr (hexadecimal)

Memory address of the pool fragment.

size (decimal)

Size, in bytes, of the pool fragment.

idx (decimal)

For internal use. Index in the array of free list pointers.

onstat -g glo command: Print global multithreading information

Use the `onstat -g glo` command to display global information about multithreading, information about each virtual processor that is currently running, and cumulative statistics for each virtual-processor class.

Syntax:

▶▶ `onstat -g glo` ◀◀

Example output

```

MT global info:
sessions threads vps lngspins
0 28 11 0

total: sched calls thread switches yield 0 yield n yield forever
per sec: 0 19577737 16256991 3688561 11340793 280099
0 0 0 0 0

Virtual processor summary:
class vps usercpu syscpu total
cpu 1 107.40 8.09 115.49
aio 6 4.19 94.42 98.61
lio 1 0.68 3.54 4.22
pio 1 0.03 0.33 0.36
adm 1 0.00 0.05 0.05
msc 1 0.00 0.01 0.01
total 11 112.30 106.44 218.74

Individual virtual processors:
vp pid class usercpu syscpu total Thread Eff
1 5738 cpu 107.40 8.09 115.49 246.14 46%
2 5739 adm 0.00 0.05 0.05 0.00 0%
3 5740 lio 0.68 3.54 4.22 36.44 11%
4 5741 pio 0.03 0.33 0.36 7.50 4%
5 5742 aio 2.03 51.92 53.95 358.09 15%

```

Figure 21-44. `onstat -g glo` command output

Output description

The following table explains each column in the global information section of the example output.

Table 21-22. Description of the columns in the virtual processor summary

Column name	Description
sessions	The number of sessions
threads	The total number of threads
vps	The total number of virtual processors
lngspins	The number of times a thread had to spin more than 10,000 times to acquire a latch on a resource
sched calls	The total number of scheduled calls.
thread switches	The total number of switches from one thread to another.
yield	Statistics on thread yields, which occur when a thread can no longer continue its task until some condition occurs

The following table explains each column in the virtual processor summary section of the example output.

Table 21-23. Description of the columns in the virtual processor summary

Column name	Description
class	The type of virtual processor.
vps	The number of instances of this class of virtual processor.

Table 21-23. Description of the columns in the virtual processor summary (continued)

Column name	Description
usercpu	The total user time, in seconds, that this class of virtual processor has spent running on the CPU.
syscpu	The total system time, in seconds, this class of virtual processor has spent running on the CPU.
total	The total number of virtual processors, user time, and system time.

The following table explains each column in the individual virtual processors section of the example output.

Table 21-24. Description of the columns for the individual virtual processors

Column name	Description
vp	The virtual processor number.
pid	The Process ID of this oninit process.
class	The type of virtual processor.
usercpu	The total user time, in seconds, that this class of virtual processor has spent running on the CPU.
syscpu	The total system time, in seconds, that this class of virtual processor has spent running on the CPU.
total	The total number of virtual processors, user time, and system time.
Thread	The total time the threads ran on this virtual processor.
Eff	Efficiency. The ratio of the total CPU time to the total time the threads ran on this virtual processor. The total CPU time is the usercpu + syscpu.

onstat -g grp command: Print ER grouper statistics

Use the **onstat -g grp** command to print statistics about the Enterprise Replication grouper.

Syntax:

```

▶▶ onstat -g grp modifier

```

The grouper evaluates the log records, rebuilds the individual log records into the original transaction, packages the transaction, and queues the transaction for transmission.

The **-g grp** option is used primarily as a debugging tool and by Technical Support.

The **onstat -g grp** command has the following formats:

```
onstat -g grp
onstat -g grp modifier
```

Valid modifier values

The following table describes the values for *modifier*.

Modifier	Action
A	Prints all the information printed by the G, T, P, E, R, and S modifiers
E	Prints grouper evaluator statistics
Ex	Prints grouper evaluator statistics, expands user-defined routine (UDR) environments
G	Prints grouper general statistics
L	Prints grouper global list
Lx	Prints grouper global list, expands open transactions
M	Prints grouper compression statistics
Mz	Clears grouper compression statistics
P	Prints grouper table partition statistics
pager	Prints grouper paging statistics
R	Prints grouper replicate statistics
S	Prints grouper serial list head (The serial list head is the first transaction in the list, that is, the next transaction that will be placed in the send queue.)
Sl	Prints grouper serial list (The serial list is the list of transactions, in chronological order.)
Sx	Prints grouper serial list, expands open transactions
T	Prints grouper transaction statistics
UDR	Prints summary information about any UDR invocations by the grouper threads
UDRx	Prints expanded information (including a summary of error information) about any UDR invocations by the grouper threads The Proc id column lists the UDR procedure ID.

Example output for the onstat -g grp command

This section contains sample output from various **onstat -g grp** *modifier* commands. The following sample shows output for the **onstat -g grp** command.

```
Grouper at 0xb014018:
Last Idle Time: (1095122236) 2004/09/13 19:37:16
RSAM interface ring buffer size: 528
RSAM interface ring buffer pending entries: 0
Eval thread interface ring buffer size: 48
Eval thread interface ring buffer pending entries: 0
Log update buffers in use: 0
Max log update buffers used at once: 5
Log update buffer memory in use: 0
Max log update buffer memory used at once: 320
Updates from Log: 16
Log update links allocated: 512
Blob links allocated: 0
Conflict Resolution Blocks Allocated: 0
Memory pool cache: Empty
Last Tx to Queuer began : (1095118105) 2004/09/13 18:28:25
Last Tx to Queuer ended : (1095118105) 2004/09/13 18:28:25
Last Tx to Queuer log ID, position: 12,23
Open Tx: 0
Serial Tx: 0
Tx not sent: 0
Tx sent to Queuer: 2
Tx returned from Queuer: 2
Events sent to Queuer: 7
Events returned from Queuer: 7
Total rows sent to Queuer: 2
Open Tx array size: 1024
Table 'tab' at 0xae8ebb0 [ CDRShadow ]
Table 'tab12' at 0xae445e0 [ CDRShadow ]
```

```

Group Table Partitions:
Slot 312...
'tab' 1048888
Slot 770...
'tab12' 3145730
Slot 1026...
'tab12' 4194306
Repl links on global free list: 2
Evaluators: 3
Evaluator at 0xb03d030 ID 0 [Idle:Idle] Protection:unused
Eval iteration: 1264
Updates evaluated: 0
Repl links on local free list: 256
UDR environment table at 0xb03d080
Number of environments:      0
Table memory limit   :    25165
Table memory used    :      0
SAPI memory limit    :   131072
SAPI memory used     :      0
Count failed UDR calls:      0
Evaluator at 0xb03d0d8 ID 1 [Idle:Idle] Protection:unused
Eval iteration: 1265
Updates evaluated: 2
Repl links on local free list: 254
UDR environment table at 0xb03d128
Number of environments:      0
Table memory limit   :    25165
Table memory used    :      0
SAPI memory limit    :   131072
SAPI memory used     :      0
Count failed UDR calls:      0
Evaluator at 0xb03d180 ID 2 [Idle:Idle] Protection:unused
Eval iteration: 1266
Updates evaluated: 4
Repl links on local free list: 256
UDR environment table at 0xb03d1d0
Number of environments:      0
Table memory limit   :    25165
Table memory used    :      0
SAPI memory limit    :   131072
SAPI memory used     :      0
Count failed UDR calls:      0
Total Free Repl links 768

```

```

Replication Group 6553601 at 0xb0a8360
Replication at 0xb0a82b0 6553601:6553601 (tab) [ NotifyDS FullRowOn ]
Column Information [ CDRShadow VarUDTs InOrder Same ]
  CDR Shadow: offset 0, size 8
  In Order: offset 8, size 10
Replication Group 6553602 at 0xb0a8480
Replication at 0xb0a83d0 6553602:6553602 (tab12) [ Ignore Stopped
NotifyDS FullRowOn ]
Column Information [ CDRShadow VarUDTs InOrder Same ]
  CDR Shadow: offset 0, size 8
  In Order: offset 8, size 16

```

Figure 21-45. `onstat -g grp` command output

Example output for the `onstat -g grp E` command

The following example shows output for the `onstat -g grp E` command. The field **Evaluators: 4** indicates that there are four evaluation threads configured for the

system.

```
Repl links on global free list: 0 Evaluators: 4
Evaluator at 0xba71840 ID 0 [Idle:Idle] Protection: unused
  Eval iteration: 1007
  Updates evaluated: 0
  Repl links on local free list: 256
  UDR environment table at 0xba71890
    Number of environments:      0
    Table memory limit   :      16777
    Table memory used    :          0
    SAPI memory limit    :     131072
    SAPI memory used     :          0
    Count failed UDR calls:      0
Evaluator at 0xba718f0 ID 1 [Idle:Idle] Protection: unused
  Eval iteration: 1007
  Updates evaluated: 0
  Repl links on local free list: 256
  UDR environment table at 0xba71940
    Number of environments:      0
    Table memory limit   :      16777
    Table memory used    :          0
    SAPI memory limit    :     131072
    SAPI memory used     :          0
    Count failed UDR calls:      0
Evaluator at 0xba8c260 ID 2 [Idle:Idle] Protection: unused
  Eval iteration: 1007
  Updates evaluated: 0
  Repl links on local free list: 256
  UDR environment table at 0xba8c2b0
    Number of environments:      0
    Table memory limit   :      16777
    Table memory used    :          0
    SAPI memory limit    :     131072
    SAPI memory used     :          0
    Count failed UDR calls:      0
Evaluator at 0xbaac2a0 ID 3 [Idle:Idle] Protection: unused
  Eval iteration: 1007
  Updates evaluated: 0
  Repl links on local free list: 256
  UDR environment table at 0xbaac2f0
    Number of environments:      0
    Table memory limit   :      16777
    Table memory used    :          0
    SAPI memory limit    :     131072
    SAPI memory used     :          0
    Count failed UDR calls:      0
Total Free Repl links 1024
```

Figure 21-46. `onstat -g grp E` command output

Example output for the `onstat -g grp G` command

The following example shows output for the `onstat -g grp G` command.

```

Grouper at 0xb8ab020:
Last Idle Time: (1095115397) 2004/09/13 17:43:17
RSAM interface ring buffer size: 1040
RSAM interface ring buffer pending entries: 0
Eval thread interface ring buffer size: 64
Eval thread interface ring buffer pending entries: 0
Log update buffers in use: 0
Max log update buffers used at once: 1
Log update buffer memory in use: 0
Max log update buffer memory used at once: 64
Updates from Log: 1
Log update links allocated: 512
Blob links allocated: 0
Conflict Resolution Blocks Allocated: 0
Memory pool cache: Empty

```

Figure 21-47. `onstat -g grp G` command output

Example output for the `onstat -g grp P` command

The following example shows output for the `onstat -g grp P` command. In the example, the grouper is evaluating rows for the **account**, **teller** and **customer** tables.

```

Table 'teller' at 0xb851480 [CDRShadow VarChars ]
Table 'account' at 0xb7faad8 [CDRShadow VarChars VarUDTs Floats Blobs]
Table 'customer' at 0xbb67a8 [CDRShadow VarChars VarUDTs]
Grouper Table Partitions:
  Slot 387...
    'account' 1048707
  Slot 389...
    'teller' 1048709
  Slot 394...
    'customer' 1048714

```

Figure 21-48. `onstat -g grp P` command output

Example output for the `onstat -g grp pager` command

The following example shows output for the `onstat -g grp pager` command. The sample output shows the grouper large transaction evaluation statistics.

```

Grouper Pager statistics:
Number of active big transactions: 0
Total number of big transactions processed: 0
Spool size of the biggest transaction processed: 0 Bytes

```

Figure 21-49. `onstat -g grp pager` command output

Example output for the `onstat -g grp R` command

The following example shows output for the `onstat -g grp R` command. In this example, the grouper is configured to evaluate rows for replicates with IDs **6553601** and **6553602** (you can use the `onstat -g cat repls` command to obtain the replicate names). The **Ignore** attribute of replicate ID **6553602** shows that the grouper is currently not evaluating rows for this replicate. This can happen if the replicate state is not **ACTIVE**. You can obtain the replicate state using the `onstat -g cat repls` command.

```

Replication Group 6553601 at 0xb0a8360
  Replication at 0xb0a82b0 6553601:6553601 (tab) [ NotifyDS FullRowOn ]
  Column Information [ CDRShadow VarUDTs InOrder Same ]
  CDR Shadow: offset 0, size 8
  In Order: offset 8, size 10
Replication Group 6553602 at 0xb0a8480
  Replication at 0xb0a83d0 6553602:6553602 (tab12) [ Ignore Stopped NotifyDS FullRowOn ]
  Column Information [ CDRShadow VarUDTs InOrder Same ]
  CDR Shadow: offset 0, size 8
  In Order: offset 8, size 16

```

Figure 21-50. `onstat -g grp R` command output

Example output for the `onstat -g grp T` command

The following example shows output for the `onstat -g grp T` command. In this example, the grouper evaluated and queued 1 transaction to the send queue. The **Tx sent to Queuer** field shows the total number of transactions evaluated and queued to the send queue for propagating to all the replicate participants. The **Total rows sent to Queuer** field shows the total number of rows queued to the send queue for propagating to all the replicate participants.

```

Last Tx to Queuer began : (1095116676) 2004/09/13 18:04:36
Last Tx to Queuer ended : (1095116676) 2004/09/13 18:04:36
Last Tx to Queuer log ID, position: 5,3236032
Open Tx: 0
Serial Tx: 0
Tx not sent: 0
Tx sent to Queuer: 1
Tx returned from Queuer: 0
Events sent to Queuer: 0
Events returned from Queuer: 0
Total rows sent to Queuer: 1
Open Tx array size: 1024

```

Figure 21-51. `onstat -g grp T` command output

`onstat -g his` command: Print SQL trace information

Use the `onstat -g his` command to display SQL trace information from the collection of `syssqltrace` tables (`syssqltrace`, `syssqltrace_info`, `syssqltrace_hvar` and `syssqltrace_itr`) in the `sysmaster` database.

The `level` setting of the `SQLTRACE` configuration parameter affects what SQL trace information is stored and displayed by the set of `syssqltrace` tables, and what information `onstat -g his` displays. Each row of the `syssqltrace` table describes a previously executed SQL statement. By default, only the DBSA can view the `syssqltrace` information from the `onstat -g his` command. However, when the `UNSECURE_ONSTAT` configuration parameter is set to 1, all users can view this information.

Syntax:

```

▶▶ onstat -g his ◀◀

```

Example output

The content of the output depends on the trace settings.

Figure 21-52. `onstat -g his` command output

The **Statement history** section in the output provides information about the current settings for tracing.

Statement history:

```
Trace Level           Low
Trace Mode            Global
Number of traces     1000
Current Stmt ID      2
Trace Buffer size     2008
Duration of buffer   293 Seconds
Trace Flags          0x00001611
Control Block        0x4c2f0028
```

The following table describes this output:

Information	Description
Trace Level	Amount of information traced. Valid values are LOW, MED, HIGH, and OFF.
Trace Mode	Type of tracing performed. Global refers to all users on the system User refers to only those users who have tracing enabled by an SQL administration API function.
Number of traces	The number of SQL statements that are being traced. This is the value set in your onconfig file unless the ntraces parameter is changed dynamically through SQL Administration API functions. The range is 500 to 2147483647. If you have 100,000 trace buffers and your organization runs 1000 SQL statements a second, and are tracing all of the statements, then the buffers would last for 100 seconds before they would begin being overwritten.
Current Stmt ID	The ID for the current SQL statement. Each statement being traced gets a unique ID.
Trace Buffer size	The amount of data each trace buffer will capture, in bytes. If you set the size to 2KB, but have an SQL statement that is 12KB, the statement is truncated by at least 10KB. More data might be truncated, depending on what else is being traced.
Duration of buffer	The amount of time, in seconds, that the trace data in the current trace buffer spans. This is not how long the sqltrace feature has been running. In the above example Duration of buffer is 293 seconds which indicates the number of seconds between the first and last SQL statement that are traced.
Trace Flags	The current SQL trace flags that are set.

Information	Description
Control Block	The memory address of the SQL trace control block.

The information displayed below is repeated one time for each time a statement was run. In this example there are two variables being called.

Statement # 2: @ 0x4c2f3028

Database: sysmaster

Statement text:

```
select count(*) from systables,syscolumns where systables.tabid > ? and
systables.nrows < ?
```

```
SELECT using tables [ systables syscolumns ]
```

The following table describes this output:

Information	Description
Database	The name of the database or part number of the systables entry for the database.
Statement text	The statement text for this SQL statement. If the statement is a stored procedure, then the statement text would display the procedure stack trace. The statement text might be truncated if the statement and the numeric statistics are larger than the trace buffer.

Iterator/Explain

=====

ID	Left	Right	Est Cost	Est Rows	Num Rows	Partnum	Type
3	0	0	17	42	146	1048579	Index Scan
4	0	0	5249	2366	2366	1048580	Seq Scan
2	3	4	5266	99372	345436	0	Nested Join
1	2	0	1	1	1	0	Group

The following table describes this output:

Information	Description
ID	SQL iterator ID
Left	ID of the left input to the iterator
Right	ID of the right input to the iterator
Est Cost	Estimated cost of this iterator
Est Rows	Estimated rows for this iterator
Num Rows	Actual number of rows for this iterator
Partnum	The table or index partition number.
Type	Type of operation

If the SQL statement contains one or more variables, and you are tracing host variables, the **Host Variables** section is included in the output.

Host Variables

=====

1	integer	100
2	float	1000.0000000000000000

The following table describes this output:

Information	Description
Column 1	The position of the variable in the statement.
Column 2	The data type of the variable.
Column 3	The value of the variable.

Statement information:

```
Sess_id  User_id  Stmt Type  Finish Time  Run Time  TX Stamp  PDQ
5        2053    SELECT    01:08:48    0.4247   340a6e9  0
```

The following table describes this output:

Information	Description
Sess_id	The session ID
User_id	The operating system user ID
Stmt Type	The type of SQL statement
Finish Time	The time of day that the SQL statement finished
Run Time	The total amount of time consumed by the virtual processors or threads used to process the statement. For example, if the Finish Time is 1:15:00 and the Run Time is 9 minutes and the start time is not necessarily 1:06:00. There might be multiple virtual processors or threads involved in processing parts of the statement in parallel.
TX Stamp	The time the BEGIN WORK statement was logged in this transaction
PDQ	The SQL statement PDQ level

The **Statement Statistics** section in the output provides specific information about the statement.

Statement Statistics:

```
Page      Buffer      Read      Buffer      Page      Buffer      Write
Read      Read      % Cache  IDX Read  Write     Write     % Cache
1285     19444     93.39    0         810      17046     95.25

Lock      Lock      LK Wait   Log      Num      Disk      Memory
Requests Waits     Time (S) Space    Sorts     Sorts     Sorts
10603    0         0.0000   60.4 KB  0         0         0

Total     Total     Avg      Max      Avg      I/O Wait  Avg Rows
Executions Time (S)  Time (S) Time (S) IO Wait   Time (S)  Per Sec
1        30.8660  30.8660  30.8660  0.0141   29.2329   169.8959

Estimated Estimated Actual   SQL     ISAM     Isolation SQL
Cost     Rows    Rows    Error   Error    Level    Memory
102     1376   5244   0       0        CR       32608
```

Information	Description
Page Read	Number of pages that have been read from disk for this SQL statement

Information	Description
Buffer Read	Number of times a page has been read from the buffer pool and not read from disk for this SQL statement
Read % Cache	Percentage of times the page was read from the buffer pool
Buffer IDX Read	This Currently not implemented
Page Write	Number of pages written to disk
Buffer Write	Number of pages modified and sent back to the buffer pool
Write % Cache	Percentage of time that a page was written to the buffer pool but not to disk
Lock Requests	Total number of locks required by this statement
Lock Waits	Number of times this SQL statement waited on locks
LK Wait Time (S)	Amount of time the statement waited for application locks, in seconds
Log Space	Amount of storage space that the SQL statement used in the logical log
Num Sorts	Total number of sorts used to execute the statement
Disk Sorts	Number of sorts which required disk space to execute the sort for this SQL statement
Memory Sorts	Number of sorts executed which executed entirely in memory for this SQL statement
Total Executions	Total number of times this prepared statement has been executed, or the number of times this cursor has been re-used
Total Time (S)	Total time this prepared statement ran, in seconds
Avg Time (S)	Average time this prepared statement required to execute, in seconds
Max Time (S)	Total time to run the prepared SQL statement, in seconds, excluding any time taken by the application. If you prepare a query then run the query 5 times, each time the query is run a trace is added to the trace buffer. The Max Time is the maximum time any one execution took.
Avg IO Wait	Average amount of time the statement waited for I/O, excluding any asynchronous I/O
I/O Wait Time (S)	Amount of time the statement waited for I/O, excluding any asynchronous I/O, in seconds
Avg Rows Per Sec	Average number of rows a second produced by this statement
Estimated Cost	The query optimizer cost associated with the SQL statement

Information	Description
Estimated Rows	Number of rows returned by the statement, as estimated by the query optimizer
Actual Rows	Number of rows returned for this statement
SQL Error	The SQL error number
ISAM Error	The RSAM or ISAM error number
Isolation Level	Isolation level this statement was run with
SQL Memory	Number of bytes this SQL statement required

For the complete schema of the **sysssqltrace** System Monitoring Interface table, see “sysssqltrace” on page 2-39.

For details of setting the SQLTRACE configuration parameter, see “SQLTRACE Configuration Parameter” on page 1-147.

Related reference:

“SQLTRACE Configuration Parameter” on page 1-147

onstat -g ioa command: Print combined onstat -g information

Use the **onstat -g ioa** command to display combined information from the **onstat -g iob**, **onstat -g ioq**, and **onstat -g iov** commands.

Syntax:

▶▶ onstat — -g — ioa ◀◀

Example output

```

AIO global info:
  7 aio es
  4 open files
  64 max global files
32768 max files from setrlimit
AIO I/O queues:
q name/id   len maxlen totalops  dskread dskwrite  dskcopy
fifo 0     0     0     0     0     0     0
adt 0     0     0     0     0     0     0
msc 0     0     0     0     0     0     0
aio 0     0     0     0     0     0     0
pio 0     0     0     0     0     0     0
lio 0     0     0     0     0     0     0
gfd 3     0     1    607     0    607     0
AIO I/O vps:
/vp s io/s totalops dskread dskwrite dskcopy wakeups io/wup polltries
pollfound kaio_pend
fifo 0 i 0.0 0     0     0     0     0     0.0 0
0     0
fifo 1 i 0.0 0     0     0     0     0     0.0 0
0     0
msc 0 i 0.0 0     0     0     0     0     0.0 0
0     0
aio 0 i 0.3 607   0    607   0    607   1.0 0
0     0
AIO global files:
gfd pathname          totalops  dskread dskwrite  io/s
3 rootdbs.1          607     0      607    0.3
AIO big buffer usage summary:
              reads
      pages  ops  pgs/op  holes  hl-ops  hls/op      writes
      pages  ops  pgs/op
fifo      0    0  0.00    0     0  0.00      0    0  0.00
kio      0    0  0.00    0     0  0.00      0    0  0.00
adt      0    0  0.00    0     0  0.00      0    0  0.00
msc      0    0  0.00    0     0  0.00      0    0  0.00
aio      0    0  0.00    0     0  0.00     607  607  1.00
pio      0    0  0.00    0     0  0.00      0    0  0.00
lio      0    0  0.00    0     0  0.00      0    0  0.00

```

Figure 21-53. `onstat -g ioa` command output

Output description

For a description of each output column, see the individual “`onstat -g iob` command: Print big buffer use summary,” “`onstat -g ioq` command: Print I/O queue information” on page 21-105, and “`onstat -g iov` command: Print AIO VP statistics” on page 21-107 commands.

`onstat -g iob` command: Print big buffer use summary

Use the `onstat -g iob` command to display a summary of big buffer use.

Syntax:

►► `onstat -g iob` ◀◀

Example output

AIO big buffer usage summary:									
reads							writes		
	pages	ops	pgs/op	holes	hl-ops	hls/op	pages	ops	pgs/op
fifo	0	0	0.00	0	0	0.00	0	0	0.00
kio	0	0	0.00	0	0	0.00	0	0	0.00
adt	0	0	0.00	0	0	0.00	0	0	0.00
msc	0	0	0.00	0	0	0.00	0	0	0.00
aio	0	0	0.00	0	0	0.00	607	607	1.00
pio	0	0	0.00	0	0	0.00	0	0	0.00
lio	0	0	0.00	0	0	0.00	0	0	0.00

Figure 21-54. **onstat -g iob** command output

onstat -g iof command: Print asynchronous I/O statistics

Use the **onstat -g iof** command to display the asynchronous I/O statistics by chunk or file.

This command is similar to the **onstat -D** command, except that **onstat -g iof** also displays information on nonchunk files. It includes information about temporary files and sort-work files.

Syntax:

▶▶ onstat -g iof ◀◀

Example output

AIO global files:						
gfd	pathname	bytes read	page reads	bytes write	page writes	io/s
3	rootdbs	1918976	937	145061888	70831	36.5
op type	count	avg. time				
seeks	0	N/A				
reads	937	0.0010				
writes	4088	0.0335				
kaio_reads	0	N/A				
kaio_writes	0	N/A				

Figure 21-55. **onstat -g iof** command output

Output description

gfd Global file descriptor number for this chunk or file.

pathname
The pathname of the chunk or file.

bytes read
Number of byte reads that have occurred against the chunk or file.

page reads
Number of page reads that have occurred against the chunk or file.

bytes write
Number of byte writes that have occurred against the chunk or file.

page writes

Number of page writes that have occurred against the chunk or file.

io/s Number of I/O operations that can be performed per second. This value represents the I/O performance of the chunk or file.

op type

Type of operation.

count Number of times the operation occurred.

avg time

Average time the operation took to complete.

onstat -g iog command: Print AIO global information

Use the **onstat -g iog** command to display global information about AIO.

Syntax:

```
▶▶ onstat -g iog ◀◀
```

Example output

```
AIO global info:
  8 aio es
  5 open files
 64 max global files
```

Figure 21-56. **onstat -g iog** command output

onstat -g ioq command: Print I/O queue information

Use the **onstat -g ioq** command to display statistics about the number and types of operations performed by I/O queues.

Syntax:

```
▶▶ onstat -g ioq [queue_name] ◀◀
```

If a *queue_name* is given then only queues with that name are shown. If no *queue_name* is given then information is given for all queues.

Example output

```

AIO I/O queues:
q name/id      len maxlen totalops  dskread dskwrite  dskcopy
sqli_dbg      0      0      0          0          0          0
fifo           0      0      0          0          0          0
adt            0      0      0          0          0          0
msc            0      0      1          537         0          0
aio           0      0      3          6537        238        5777
pio           0      0      2          1103         0        1102
lio           0      0      2          11795        0        11794
gfd            3      0     17          17489        1526       15963
gfd            4      0     17          18347        2384       15963
gfd            5      0     16           220          41         179
gfd            6      0      4            4            0           4
gfd            7      0      4            4            0           4
gfd            8      0      4            4            0           4
gfd            9      0      9            54           24          30
gfd           10      0     16           149           40          109
gfd           11      0     16           621           128         493
gfd           12      0     16          1953          1146        807
gfd           13      0     16           409            71         338
gfd           14      0     16           378            60         318

```

Figure 21-57. `onstat -g ioq` command output

Output description

q name/id

The name and number of the I/O queue. The name indicates what type of queue it is. The number is used to tell queues of the same name apart.

Here is a list of the possible queue names and what each type of queue handles:

sqli_dbg

Handles I/O for IBM Technical Support's SQL Interface Debugging feature

fifo Handles I/O for FIFO VPs

adt Handles auditing I/O

msc Handles miscellaneous I/O

aio Handles IBM Informix asynchronous I/O

kio Handles kernel AIO

pio Handles physical logging I/O

lio Handles logical logging I/O

gfd Global File Descriptor - Each primary and mirror chunk is given a separate global file descriptor. Individual gfd queues are used depending on whether kaio is on and the associated chunk is cooked or raw.

len The number of pending I/O requests in the queue

maxlen

The largest number of I/O requests that have been in the queue at the same time

totalops

The total number of I/O operations that have been completed for the queue

dskread

Total number of completed read operations for the queue

dskwrite

Total number of completed write operations for the queue

dskcopy

Total number of completed copy operations for the queue

onstat -g ipl command: Print index page logging status information

Use the **onstat -g ipl** command to display information about the status of index page logging.

Syntax:

▶▶—onstat— -g—ipl—————▶▶

Example output

```
Index page logging status: Enabled
Index page logging was enabled at: 2008/12/20 16:01:02
```

Figure 21-58. onstat -g ipl command output

Output description**Index page logging status**

Status of index page logging: Enabled or Disabled.

Index page logging was enabled at

The date and time at which index page logging was enabled.

onstat -g iov command: Print AIO VP statistics

Use the **onstat -g iov** command to display asynchronous I/O statistics for each virtual processor.

Syntax:

▶▶—onstat— -g—iov—————▶▶

Example output

```

AIO I/O vps:
class/vp/id s io/s totalops dskread dskwrite dskcopy wakeups io/wup errors tempops
fifo 7 0 i 0.0 0 0 0 0 1 0.0 0 0
msc 6 0 i 0.1 9988 0 0 0 7833 1.3 0 9988
aio 5 0 i 0.0 4894 3341 1426 0 4393 1.1 0 0
aio 9 1 i 0.0 41 0 41 0 33 1.2 0 0
pio 4 0 i 0.0 199 0 199 0 200 1.0 0 199
lio 3 0 i 0.0 6344 0 6344 0 6344 1.0 0 6344

```

Figure 21-59. `onstat -g iov` command output

Output description

class The class of the virtual processor.

vp The ID number of the virtual processor within its class.

s Current status of the AIO virtual processor

f Fork

i Idle

s Search

b Busy

o Open

c Close

io/s The average I/O speed (measured in operations per second) for the virtual processor since the time the database server started or since the `onstat -z` command was last run, whichever happened last.

totalops

Total number of I/O operations performed by this virtual processor since the time the database server started or since the `onstat -z` command was last run, whichever happened last.

dskread

Total number of read operations performed by this virtual processor since the time the database server started or since the `onstat -z` command was last run, whichever happened last.

dskwrite

Total number of write operations performed by this virtual processor since the time the database server started or since the `onstat -z` command was last run, whichever happened last.

dskcopy

Total number of copy operations performed by this virtual processor since the time the database server started or since the `onstat -z` command was last run, whichever happened last.

wakeups

For AIO VPs, the number of times the virtual processor has gone idle since the time the database server started or since the `onstat -z` command was last run, whichever happened last.

io/wup

For AIO VPs, the average number of I/O operations performed per wake-up by this virtual processor since the time the database server started or since the `onstat -z` command was last run, whichever happened last.

errors Total number of KAIO out of resource errors.

tempops (decimal)

For internal use only. This is I/O operation counter that is maintained to determine when a new AIO VP should be added. It is applicable only when the AUTO_AIOVPS configuration parameter is enabled.

onstat -g lap command: Print light appends status information

Use the **onstat -g lap** command to display information about the status of light appends occurring in the system.

Syntax:

▶▶ onstat -g lap ▶▶

Example output

Light Append Info						
session id	address	cur_ppage	la_npused	la_ndata	la_nrows	bufcnt
31	b60a5e8	ffbff494	2938	2937	93990	4

Figure 21-60. onstat -g lap command output

Output description

Session id (decimal)

Session ID performing the light append operation

address (hexadecimal)

Address of the light append buffer

cur_ppage (hexadecimal)

Current physical page address

la_npused (decimal)

Number of pages allocated

la_ndata (decimal)

Number of data pages appended

la_nrows (decimal)

Number of rows appended

bufcnt (decimal)

Number of light append buffers

onstat -g laq command: Print secondary server queues

Use the **onstat -g laq** command to print information about queues on the secondary server that apply log information received from the primary server.

In a high-availability cluster, the primary server sends log records to one or more secondary servers over the network. Each secondary server continuously replays the transaction logs from the primary server to ensure that data is replicated on the secondary server. Each tblspace on the primary server is assigned a queue on the secondary server in which to receive log records. A thread, called an *apply thread*, applies the logs stored in the queue to the secondary server. The logs are applied in the order in which they were received.

You use the **onstat -g laq** command to monitor the performance of the queues on the secondary server. Use this command if you suspect that the primary server performance is slowed because logs are not replaying quickly enough on the secondary server. The Avg Depth (average depth) column indicates the average number of logs in the queue at the time that the last queue insert operation occurred.

The **onstat -g laq** command is valid only on secondary servers. Running the command on the primary server returns only the **onstat** header output.

Syntax:

►► onstat — -g — laq ◀◀

Example output

Log Apply Info:			
Thread	Queue Size	Total Queued	Avg Depth
xchg_1.0	0	9	5.00
xchg_1.1	0	0	0.00
xchg_1.2	0	7	3.43
xchg_1.3	0	8	1.12
xchg_1.4	0	4	1.50
xchg_1.5	0	4	1.50
xchg_1.6	0	6	1.33
xchg_1.7	0	47	3.11
xchg_1.8	0	37	9.46
xchg_1.9	0	13	3.69

Secondary Apply Queue:	Total Buffers:12 Size:64K Free Buffers:11
Log Recovery Queue:	Total Buffers:4 Size:32K Free Buffers:2
Log Page Queue:	Total Buffers:32 Size:2K Free Buffers:32
Log Record Queue:	Total Buffers:50 Size:64K Free Buffers:49

Figure 21-61. **onstat -g laq** command output

Output description

Thread

The name of the apply thread assigned to receive the log record.

Queue Size

The number of log records queued for the apply thread.

Total Queued

The total number of queued log records for a given apply thread.

Avg Depth

The average number of logs in the queue at the time that the last queue insert operation occurred.

Secondary Apply Queue

The secondary apply queue receives log buffers from the primary server. The values displayed represent the total number of buffers allocated to receiving log buffer records, the size of the queue, and the number of unused buffers.

Log Recovery Queue

The log recovery queue receives output from the secondary apply queue.

The log buffers are converted to a format compatible with the **ontape** utility. The values displayed represent the total number of stream buffers in the recovery queue, the size of the stream buffers, and the number of unused buffers.

Log Page Queue

The log page queue receives output from the log recovery queue. The **ontape** formatting is removed and the data is divided into individual log pages. The values displayed represent the total number of log pages in the queue, the size of the queue, and the number of unused buffers.

Log Record Queue

The log record queue receives output from the log page queue. The log pages are divided into individual log records. The values displayed represent the total number of log records in the recovery queue, the size of the queue, and the number of unused buffers.

onstat -g lmm command: Print low memory management information

Use the **onstat -g lmm** command to display information about automatic low memory management settings and recent activity.

Syntax:

▶▶—onstat— -g lmm—▶▶

Example output

```

Low Memory Manager

Control Block      0x4cfca220
Memory Limit      300000 KB
Used              149952 KB
Start Threshold   10240 KB
Stop Threshold    10 MB
Idle Time         300 Sec
Internal Task     Yes
Task Name         'Low Memory Manager'
Low Mem TID       0x4cfd7178
# Extra Segments  0

Low Memory Manager Tasks

Task              Count    Last Run
Kill User Sessions 267     04/04/2011.16:57
Kill All Sessions  1       04/04/2011.16:58
Reconfig(reduce)  1       04/04/2011.16:59
Reconfig(restore) 1       04/04/2011.17:59

Last 20 Sessions Killed

Ses ID Username Hostname PID   Time
194   sfisher  host01  13433 04/04/2011.16:57
201   sfisher  host01  13394 04/04/2011.16:57
198   sfisher  host01  13419 04/04/2011.16:57
190   sfisher  host01  13402 04/04/2011.16:57
199   sfisher  host01  13431 04/04/2011.16:57

Total Killed 177

```

Figure 21-62. `onstat -g lmm` command output

Output description

Control Block

Address of the internal control structure for automatic low memory management

Memory Limit

Amount of memory to which the server is attempting to adhere

Used Amount of memory currently used by the server

Start Threshold

Value for the automatic low memory management start threshold

Stop Threshold

Value for the automatic low memory management stop threshold

Idle Time

The amount of time after which automatic low memory management considers a session idle

Internal Task

Yes = using Informix procedures

No = using user-defined procedures

Task Name

Name of user-defined procedure

Low Mem TID

Address of the automatic low memory management thread

Task Kill = Automatic processes ran and terminated sessions.
 Reconfig(reduce) = Automatic processes ran and freed blocks of unused memory.
 Reconfig(restore) = Automatic processes ran and restored services and configuration.

Count Number of times that the task ran

Last Run
 Date and time when the last task ran

Ses ID
 ID of session that was terminated (with an **onmode -z** command)

Username
 User name of the owner of the session

Hostname
 Name of the host where the session originated

PID Process ID

Time Date and time when the session was terminated

You use the `LOW_MEMORY_MGR` configuration parameter to enable the automatic low memory management.

Related reference:

“scheduler lmm enable argument: Specify automatic low memory management settings (SQL administration API)” on page 22-102

“scheduler lmm disable argument: Stop automatic low memory management (SQL administration API)” on page 22-105

onstat -g lmx command: Print all locked mutexes

Use the **onstat -g lmx** command to display information about all locked mutexes.

Syntax:

▶▶ onstat -g lmx ◀◀

Example output

```
Locked mutexes:
mid   addr      name      holder  lkcnt  waiter  waittime
3258  17389dc8  nsf.lock  1313    0      13      491
                                           1184
                                           188
Number of mutexes on VP free lists: 49
```

Figure 21-63. **onstat -g lmx** command output

Output description

mid Internal mutex identifier
addr Address of locked mutex
name Name of the mutex

holder Thread ID of the thread holding the mutex
lkcnt Number of waiters for this mutex
waiter List of addresses waiting for this mutex
waittime
Amount of time this thread has been waiting

onstat -g lsc command: Print active light scan status (deprecated)

The **onstat -g lsc** command has been superseded by the **onstat -g scn** command.

Syntax:

▶▶ onstat -g lsc ◀◀

Example output

Light Scan Info						
descriptor	address	next_lpage	next_ppage	ppage_left	bufcnt	look_aside
3	474b74b0	4a0	7e2c80	416	1	N

Figure 21-64. **onstat -g lsc** command output

Output description

descriptor (decimal)

Light scan ID

address (hex)

Memory address of the light scan descriptor

next_lpage (hex)

Next logical page address to scan

next_ppage (hex)

Next physical page address to scan

ppage_left (decimal)

Number of physical pages left to scan in the current extent

#bufcnt (decimal)

Number of light scan buffers used for this light scan

#look_aside (char)

Whether look aside is needed for this light scan (Y = yes, N = no). Look asides occur when a thread needs to examine the buffer pool for existing pages to obtain the latest image of a page being light scanned.

Use the **onstat -g scn** command to display the status of a current scan, based on rows scanned on compressed tables, tables with rows that are larger than a page, and tables with VARCHAR, LVARCHAR, and NVARCHAR data. For more information, see “**onstat -g scn** command: Print scan information” on page 21-155.

onstat -g mem command: Print pool memory statistics

Use the **onstat -g mem** command to display the memory statistics for a pool.

Syntax:

```
▶▶ onstat -g mem [pool name—session id] ▶▶
```

Session pools are named with the session number. If no argument is provided, information about all pools is displayed.

Example output

```
Pool Summary:
name          addr          totalsize freesize #allocfrag #freefrag
resident     R    10a001028    2420736   7960      2           2
res-buff     R    10a250028    8269824   7960      2           2
global      V    10aac0028    9351168   32648    650        11
...
...
...
onmode_mon  V    10b983028     20480    2752     108         1
13         V    10bd5d028    16384    5200     12         2
Blkpool Summary:
name          addr          size      #blks    pre-hint  szavail|
global      V    10aac8920      0         0         0         0
xmf_msc_pl  V    10ac84ca0   954368    73         0         0
```

Figure 21-65. `onstat -g mem` command output

Output description

Pool Summary

name Pool name

Shared memory segment type where the pool is created

addr Pool memory address

totalsize

Pool size, in bytes

freesize

Free memory in pool

#allocfrag

Allocated fragments in pool

#freefrag

Free fragments in pool

Blkpool Summary

name Pool name

Shared memory segment type where pool is created

addr Pool memory address

size Pool size, in bytes

#blks Number of blocks in pool

onstat -g mgm command: Print MGM resource information

Use the **onstat -g mgm** command to display resource information about Memory Grant Manager (MGM).

You can use the **onstat -g mgm** command to monitor how MGM coordinates memory use and scan threads. This command reads shared-memory structures and provides statistics that are accurate at the instant that the command executes.

Syntax:

▶▶—onstat— -g—mgm—————▶▶

The **onstat -g mgm** output displays a unit of memory called a *quantum*. The *memory quantum* represents a unit of memory, as follows:

$$\text{memory quantum} = \text{DS_TOTAL_MEMORY} / \text{DS_MAX_QUERIES}$$

The following calculation shows the memory quantum for the values that the **onstat -g mgm** output displays:

$$\begin{aligned} \text{memory quantum} &= 4000 \text{ kilobytes} / 31 \\ &= 129 \text{ kilobytes} \end{aligned}$$

The *scan thread quantum* is always equal to 1.

Example output

```

Memory Grant Manager (MGM)
-----
MAX_PDQPRIORITY: 100
DS_MAX_QUERIES: 31
DS_MAX_SCANS: 1048576
DS_NONPDQ_QUERY_MEM: 128 KB
DS_TOTAL_MEMORY: 4000 KB

Queries:  Active    Ready    Maximum
          0         0         31
Memory:   Total     Free     Quantum
(KB)      4000    4000    128

Scans:    Total     Free     Quantum
          1048576  1048576  1

Load Control:  (Memory)      (Scans) (Priority) (Max Queries) (Reinit)
              Gate 1      Gate 2   Gate 3      Gate 4      Gate 5
(Queue Length) 0         0       0           0           0

Active Queries: None
Ready Queries:  None
Free Resource   Average #      Minimum #
-----
Memory          0.0 +- 0.0     500
Scans           0.0 +- 0.0    1048576

Queries        Average #      Maximum #      Total #
-----
Active         0.0 +- 0.0     0              0
Ready          0.0 +- 0.0     0              0

Resource/Lock Cycle Prevention count: 0

```

Figure 21-66. `onstat -g mgm` command output

Output description

The first portion of the output shows the values of the PDQ configuration parameters.

The second portion of the output describes MGM internal control information. It includes four groups of information. The first group is **Queries**:

Active Number of PDQ queries that are currently executing

Ready Number of user queries ready to run but whose execution the database server deferred for load-control reason

Maximum

Maximum number of queries that the database server permits to be active. Reflects current value of the `DS_MAX_QUERIES` configuration parameter

The next group is **Memory**:

Total Kilobytes of memory available for use by PDQ queries (`DS_TOTAL_MEMORY` specifies this value.)

Free Kilobytes of memory for PDQ queries not currently in use

Quantum

Kilobytes of memory in a memory quantum

The next group is **Scans**:

Total The total number of scan threads as specified by the DS_MAX_SCANS configuration parameter

Free Number of scan threads currently available for decision-support queries

Quantum
The number of scan threads in a scan-thread quantum

The last group in this portion of the output describes **MGM Load Control**:

Memory
Number of queries that are waiting for memory

Scans Number of queries that are waiting for scans

Priority
Number of queries that are waiting for queries with higher PDQ priority to run

Max Queries
Number of queries that are waiting for a query slot

Reinit Number of queries that are waiting for running queries to complete after an **onmode -M** or **-Q** command

The next portion of the output, **Active Queries**, describes the MGM active and ready queues. This portion of the output shows the number of queries waiting at each gate:

Session The session ID for the session that initiated the query

Query Address of the internal control block associated with the query

Priority
PDQ priority assigned to the query

Thread Thread that registered the query with MGM

Memory
Memory currently granted to the query or memory reserved for the query (Unit is MGM pages, which is 8 kilobytes.)

Scans Number of scan threads currently used by the query or number of scan threads allocated to the query

Gate Gate number at which query is waiting

The next portion of the output, **Free Resource**, provides statistics for MGM free resources. The numbers in this portion and in the final portion reflect statistics since system initialization or the last **onmode -Q**, **-M**, or **-S** command. This portion of the output contains the following information:

Average
Average amount of memory and number of scans

Minimum
Minimum available memory and number of scans

The next portion of the output, **Queries**, provides statistics concerning MGM queries:

Average
Average active and ready queue length

Maximum

Maximum active and ready queue length

Total

Total active and ready queue length

Resource/Lock Cycle Prevention count

Number of times the system immediately activated a query to avoid a potential deadlock. (The database server can detect when some of the queries in its queue might create a deadlock situation if the queries are not run immediately.)

onstat -g nbm command: Print a block bit map

Use the **onstat -g nbm** command to display the block bit map for the nonresident segments.

Each bit of the bitmap represents a 4 KB block. If the block is used, then the bit is set to 1. If the block is free, the bit is set to 0. The bitmap is shown as a series of hexadecimal numbers. The bits, and therefore the blocks, are numbered starting at 0 so the first block is block 0, the second is block 1, and so on.

Syntax:

▶▶—onstat— -g—nbm—————▶▶

Example output

This example shows the bitmap for the segment of virtual memory at 0x10CC0000. The bitmap itself is at 0x10CC00290. All 1792 blocks of the segment are free except for block 0 and block 1023.

```

Block bitmap for virtual segment address 0x10cc00000:
address = 0x10cc00290, size(bits) = 1792
used = 1, largest_free = -1
  0:8000000000000000 0000000000000000 0000000000000000 0000000000000000
 256:0000000000000000 0000000000000000 0000000000000000 0000000000000000
 512:0000000000000000 0000000000000000 0000000000000000 0000000000000000
 768:0000000000000000 0000000000000000 0000000000000000 0000000000000001
1024:0000000000000000 0000000000000000 0000000000000000 0000000000000000
1280:0000000000000000 0000000000000000 0000000000000000 0000000000000000
1536:0000000000000000 0000000000000000 0000000000000000 0000000000000000

```

Figure 21-67. onstat -g nbm command output

Output description

address

The starting address of the bitmap.

size

The number of bits in the bitmap. This is also the number of 4 KB blocks in the memory segment.

used

The total number of bits in the bitmap that are set to 1. This is also the number of 4 KB blocks that are in use in the memory segment.

largest free

If this is a value other than -1 it is the largest number of consecutive bits that are free, which is also the number of 4 KB blocks in the largest contiguous set of blocks in the memory segment.

A value of -1 means that the largest free space has not been calculated. The database server only calculates the largest free space if it tries to allocate a set of blocks starting at the *lastalloc* block but there is not enough free space. The value is set to -1 again as soon as another block is allocated in the segment.

onstat -g nif command: Print statistics about the network interface

Use the **onstat -g nif** command to display statistics about the network interface.

The **onstat -g nif** command is used primarily as a debugging tool , most often by Technical Support.

The output shows which sites are connected and provides a summary of the number of bytes sent and received by each site. This can help you determine if a site is not sending or receiving bytes.

Syntax:



The following table describes the options for the **onstat -g nif** command:

Option	Action
all	Prints the sum and the sites.
sites	Prints the NIF site context blocks.
<i>server_ID</i>	Prints information about the replication server with that server ID.
sum	Prints the sum of the number of buffers sent and received for each site.

Example output

The following example shows output for the **onstat -g nif** command. In this example, the local server is connected to the server group **g_bombay** and its CDR ID is **200**. The connection status is running. The connection between the two servers is running, but the replication state on the **g_bombay** server is suspended. The server group **g_bombay** internal NIF version is **9**. The local server has sent three messages to the server **g_bombay** and it has received two messages from **g_bombay**.

```

NIF anchor Block: af01610
    nifGState      RUN
    RetryTimeout   300

CDR connections:
  Id   Name      State   Version   Sent   Received
-----
  200  g_bombay   RUN,SUSPEND  9       3       2

```

Figure 21-68. `onstat -g nif` command output

Output description

NIF anchor Block

The address of the network storage block.

nifGState

The connection state.

RetryTimeout

The number of seconds before Enterprise Replication attempts to retry a dropped connection.

Id

The Enterprise Replication ID number for the server.

Name

The name of the server group.

State

The connection state between the local server and the listed server. If multiple states are shown the second state designates the replication state.

Version

The internal version number of the NIF component on the listed server.

Sent

The number of messages the local server has sent to the listed server.

Received

The number of messages received by the local server from the listed server.

onstat -g nsc command: Print current shared memory connection information

Use the `onstat -g nsc` command to display information about shared memory connections either for all of the current connections or for a specified connection ID.

Syntax:

```

▶▶ onstat -g nsc [client_id] ▶▶

```

If no `client_id` is provided, information about all current shared memory connections to the database server is given. If a `client_id` is provided then this command gives more detailed information about the shared memory connection with that ID.

Example output

This is output of `onstat -g nsc` with no `client_id`. It shows that there is only one user currently connecting to the database server through shared memory. That

connection has an ID of 0.

clientid	clientPID	state	#serverbufs	#clientbufs	#rdwrts
0	6031	Connected	4	4	12

Figure 21-69. `onstat -g nsc` command output

This example shows output from running the command using a `client_id` of 0.

```
Network Shared Memory Status for Client: 0
```

clientid	clientPID	state	#serverbufs	#clientbufs	#rdwrts
0	18949	Connected	4	4	447048

needbuf	segid	semid	semnum	be_semid	be_semnum
0	1303	851969	0	851969	10

be_curread	be_curwrite	fe_curread	fe_curwrite
-1	1	0	2

be_nextread	be_nextwrite	fe_nextread	fe_nextwrite
2	2	4	3

```
readyqueue
```

-1	-1	-1	-1	-1	-1	-1	-1	-1	-1	-1
----	----	----	----	----	----	----	----	----	----	----

Server Buffers				Client Buffers				
i:	bufid	status	offset	fe_addr	bufid	status	offset	fe_addr
0:	4	inuse	4474	804474	0	avail	3424	803424
1:	5	inuse	4888	804888	1	avail	3838	803838
2:	6	avail	4c9c	804c9c	2	inuse	3c4c	803c4c
3:	7	avail	50b0	8050b0	3	avail	4060	804060
4:	-1	free	0	0	-1	free	0	0
5:	-1	free	0	0	-1	free	0	0

Figure 21-70. `onstat -g nsc` command with client id output

Output description

clientid

Server assigned ID

clientPID

Client process ID

state State of connection

Connected

The client has established a connection with the server.

Con1 The server has successfully set up a connection with the client, but the client has not yet been notified of it.

Waiting

The server is in the process of setting up a connection with the client.

Reject Client connection has been rejected by the server, normally because the server is shutting down or not yet in on-line mode.

Closed

Server has closed the connection with the client. Client might not be aware of the fact yet.

Not connected

Server is initializing internal structures for the connection.

Unknown

Connection has been closed and the client is aware of the fact. Server is cleaning up internal structures.

#serverbufs

Database server buffers currently allocated

#clientbufs

Client buffers currently allocated

#rdwrts

The total number of reads and writes performed through this connection since it was created.

The following items are only in the output if you run the **onstat -g nsc** command with a *client_id*:

needbuf

Indicates if server is waiting for a buffer to be freed

0 False

1 True

segid Shared memory segment ID

semid Semaphore ID

semnum

Semaphore number in the semaphore ID

be_semid

Backend semaphore ID

be_semnum

Backend semaphore number in the semaphore ID

be_curread

ID of backend buffer being read

be_curwrite

ID of backend buffer being written

fe_curread

ID of frontend buffer being read

fe_currwrite

ID of frontend buffer being written

be_nextread

ID of next backend buffer to be read

be_nextwrite

ID of next backend buffer to be written

fe_nextread

ID of next frontend buffer to be read

fe_nextwrite
ID of next frontend buffer to be written

readyqueue
Queue of the shared memory buffer ids

Buffers

i Internal location key of message buffer

bufid Message buffer ID

status Status of message buffer

offset Offset of memory buffer in shared memory segments

fe_addr
Frontend address of message buffer

Related reference:

“NETTYPE Configuration Parameter” on page 1-101

onstat -g nsd command: Print poll threads shared-memory data

Use the **onstat -g nsd** command to display information about shared-memory data for poll threads.

Syntax:

▶▶ onstat -g nsd ◀◀

Example output

```
Network Shared Memory Data for Poll Thread: 0
Free Message Buffer Bitmap
(bitmap address = 10b9eef80, bitmap size 480)
000000010b9eef80:ffffffff ffffffff ffffffff ffffffff ffffffff ffffffff ffffffff ffffffff
000000010b9eefa0:ffffffff ffffffff ffffffff ffffffff ffffffff ffffffff ffffffff
Free Message Buffer Status Bitmap
(bitmap address = 10ca0a9b0, bitmap size 50)
000000010ca0a9b0:ffffffff ffffff
Message Buffer Table
bufid  clientid      addr
Message Buffer Status Table
clientid  netscb addr      addr      offset
```

Figure 21-71. **onstat -g nsd** command output

Related reference:

“NETTYPE Configuration Parameter” on page 1-101

onstat -g nss command: Print shared memory network connections status

Use the **onstat -g nss sessionid** command to display information about the status of the shared memory network connections.

Syntax:

```
▶▶ onstat -g nss [sessionid] ▶▶
```

If no *sessionid* is provided, a one-line summary for each shared memory connection is listed.

Example output

clientid	clientPID	state	#serverbufs	#clientbufs	#rdwrts
1	14018	Connected	4	4	331
0	12398	Connected	4	4	294
2	14036	Connected	4	4	59

Figure 21-72. `onstat -g nss` command output

Output description

clientid (decimal)

Server assigned value for lookups

clientPID (decimal)

Client process ID

state (string)

Current state of the connection.

- Connected
- Con1
- Waiting
- Reject
- Bedcover
- Closed
- Not connected
- Unknown

#serverbufs (dec)

Number of database server buffers currently allocated

#clientbufs (dec)

Number of client buffers currently allocated

#rdwrts (dec)

Total number of buffers in use

Related reference:

“NETTYPE Configuration Parameter” on page 1-101

onstat -g ntd command: Print network statistics

Use the `onstat -g ntd` command to display network statistics by service.

Syntax:

```
▶▶ onstat -g ntd ▶▶
```

Example output

```
global network information:
#netscb connects      read      write q-limits  q-exceed alloc/max
4/ 5      11        0      3546 3549/ 10  10/ 0      0/ 0

Client Type    Calls   Accepted  Rejected      Read      Write
sqlxec         yes     11         0             3531     3540
srvinfx        yes     0          0             0         0
onspac         yes     0          0             4         9
onlog          yes     0          0             0         0
onparam        yes     0          0             0         0
oncheck        yes     0          0             0         0
onload         yes     0          0             0         0
onunload       yes     0          0             0         0
onmonitor      yes     0          0             0         0
dr_accept      yes     0          0             0         0
cdraccept      no      0          0             0         0
ontape         yes     0          0             0         0
srvstat        yes     0          0             0         0
asfecho        yes     0          0             0         0
listener       yes     0          0             11        0
crsamexec      yes     0          0             0         0
onutil         yes     0          0             0         0
drdaexec       yes     0          0             0         0
smx            yes     0          0             0         0
safe           yes     0          0             0         0
Totals                    11         0             3546     3549
```

Figure 21-73. `onstat -g ntd` command output

`onstat -g ntm` command: Print network mail statistics

Use the `onstat -g ntm` command to display statistics about network mail.

Syntax:

```
▶▶ onstat -g ntm ◀◀
```

Example output

```
global network information:
#netscb connects      read      write q-limits  q-exceed alloc/max
4/ 5      11        0      3546 3549/ 10  10/ 0      0/ 0

Network mailbox information:
box  netscb thread name      max received  in box  max in box full signal
5  f07e8b0 soctcpoll      10      24      0      1      0      yes
6  f0b6ad8 soctcplst      10      0      0      0      0      no
7  f0e8b18 soctcplst      10      0      0      0      0      no
```

Figure 21-74. `onstat -g ntm` command output

`onstat -g ntt` command: Print network user times

Use the `onstat -g ntt` command to display information about network user times.

Syntax:

```
▶▶ onstat -g ntt
```

Example output

```
global network information:
#netscb connects      read      write      q-limits  q-exceed alloc/max
3/ 3      0      0      0      135/ 10      0/ 0      2/ 0
Individual thread network information (times):
netscb  thread name  sid  open      read      write      address
c76ea28  ontape          61   14:34:48  14:34:50  14:34:50
c63e548  tlitcplst      4    14:30:43  14:34:48
c631028  tlitcpoll      3    14:32:32
```

Figure 21-75. `onstat -g ntt` command output

`onstat -g ntu` command: Print network user statistics

Use the `onstat -g ntu` command to display information about network user statistics.

Syntax:

```
▶▶ onstat -g ntu
```

Example output

```
global network information:
#netscb connects      read      write      q-free  q-limits  q-exceed alloc/max
2/ 3      16      2611      2603      1/ 1      135/ 10      0/ 0      1/ 1
Individual thread network information (basic):
netscb  type  thread name  sid  fd  poll  reads  writes  q-nrm  q-pvt  q-exp
d1769f0  soctcp  soctcplst    3    1    5      16      0  0/ 0  0/ 0  0/ 0
d1199f0  soctcp  soctcpoll    2    0    5     2595      0  0/ 0  0/ 0  0/ 0
```

Figure 21-76. `onstat -g ntu` command output

`onstat -g opn` command: Print open partitions

Use the `onstat -g opn` command to display a list of the partitions (tables and indexes), by thread ID, that are currently open in the system.

Use the `thread_id` option to restrict the list to a specified ID.

Syntax:

```
▶▶ onstat -g opn [thread_id]
```

Example output

tid	rstcb	isfd	op_mode	op_flags	partnum	ucount	ocount	lockmode
38	0x00000000460db7b0	0	0x00000400	0x00000397	0x001000af	2	2	0
38	0x00000000460db7b0	1	0x00000002	0x00000117	0x001000af	2	2	0
38	0x00000000460db7b0	2	0x00000440	0x00000797	0x0010010c	2	0	0
38	0x00000000460db7b0	3	0x00000400	0x00000407	0x0010010a	2	0	0
38	0x00000000460db7b0	4	0x00000400	0x00000407	0x0010010a	2	0	0
38	0x00000000460db7b0	5	0x00000002	0x00000003	0x00100003	2	2	0
38	0x00000000460db7b0	6	0x00000400	0x00000397	0x00100003	2	2	0
38	0x00000000460db7b0	7	0x00000400	0x00000413	0x0010010f	2	0	0
38	0x00000000460db7b0	8	0x00000440	0x00000797	0x0010010c	2	0	0
38	0x00000000460db7b0	9	0x00000402	0x00000403	0x0010010f	2	0	0
38	0x00000000460db7b0	10	0x00000442	0x00000403	0x00100111	1	0	0
38	0x00000000460db7b0	11	0x00000442	0x00000403	0x00100110	1	0	0
38	0x00000000460db7b0	12	0x00000442	0x00000403	0x00100112	1	0	0
38	0x00000000460db7b0	15	0x00000400	0x00004407	0x00000006	1	0	0
38	0x00000000460db7b0	16	0x00000400	0x00000413	0x00100119	1	0	0
36	0x00000000460dbf98	0	0x00000400	0x00000397	0x001000af	2	2	0
36	0x00000000460dbf98	1	0x00000002	0x00000003	0x001000af	2	2	0
36	0x00000000460dbf98	3	0x00000402	0x00000407	0x0010010a	2	0	0
36	0x00000000460dbf98	4	0x00000400	0x00000413	0x0010010a	2	0	0
36	0x00000000460dbf98	6	0x00000442	0x00000797	0x0010010c	1	0	0
37	0x00000000460dc780	0	0x00000400	0x00000397	0x001000af	2	2	0
37	0x00000000460dc780	1	0x00000002	0x00000117	0x001000af	2	2	0
37	0x00000000460dc780	2	0x00000400	0x00000407	0x0010010a	2	0	0
37	0x00000000460dc780	3	0x00000440	0x00000797	0x0010010c	2	0	0
37	0x00000000460dc780	4	0x00000400	0x00000413	0x0010010f	2	0	0
37	0x00000000460dc780	5	0x00000400	0x00000407	0x0010010a	2	0	0
37	0x00000000460dc780	6	0x00000440	0x00000797	0x0010010c	2	0	0
37	0x00000000460dc780	7	0x00000400	0x00000397	0x00100003	2	2	0
37	0x00000000460dc780	8	0x00000002	0x00000003	0x00100003	2	2	0
37	0x00000000460dc780	9	0x00000442	0x00000403	0x00100111	1	0	0
37	0x00000000460dc780	10	0x00000442	0x00000403	0x00100110	1	0	0
37	0x00000000460dc780	11	0x00000402	0x00000403	0x0010010f	2	0	0
37	0x00000000460dc780	12	0x00000400	0x00000413	0x00100119	1	0	0
37	0x00000000460dc780	13	0x00000442	0x00000403	0x00100112	1	0	0
37	0x00000000460dc780	14	0x00000400	0x00004407	0x00000006	1	0	0

Figure 21-77. `onstat -g opn` command output

Output description

tid (decimal)

Thread ID currently accessing the partition resource (table/index)

rstcb (hexadecimal)

In-memory address of the RSAM thread control block for this thread

isfd (decimal)

ISAM file descriptor associated with the open partition

op_mode (hexadecimal)

Current status of the partition lock mode using a combination of the following hexadecimal values:

- 0x000000 Open for input only
- 0x000001 Open for output only
- 0x000002 Open for input and output
- 0x000004 System catalog
- 0x000008 No logical logging
- 0x000010 Open if not already opened for alter
- 0x000020 Open all fragments data and index
- 0x000040 Do not allocate a blob descriptor
- 0x000080 Open for alter
- 0x000100 Open all data fragments

0x000200 Automatic record lock
 0x000400 Manual record lock
 0x000800 Exclusive ISAM file lock
 0x001000 Ignore dataskip - data cannot be ignored
 0x002000 Dropping partition - delay file open
 0x004000 Do not drop blob space blobs when table dropped
 (alter fragment)
 0x010000 Open table for DDL operations
 0x040000 Do not assert fail if this partnum does not exist
 0x080000 Include fragments of subtables
 0x100000 Table created under supertable
 0x400000 Blob in use by CDR

op_flags (hexadecimal)

Current status of the partition using a combination of the following hexadecimal values:

0x0001 Open data structure is in use
 0x0002 Current position exists
 0x0004 Current record has been read
 0x0008 Duplicate created or read
 0x0010 Skip current record on reverse read
 0x0020 Shared blob information
 0x0040 Partition opened for rollback
 0x0080 Stop key has been set
 0x0100 No index related read aheads
 0x0200 isstart called for current stop key
 0x0400 Pseudo-closed
 0x0800 Real partition opened for SMI query
 0x1000 Read ahead of parent node is done
 0x2000 UDR keys loaded
 0x4000 Open is for a pseudo table
 0x8000 End of file encountered when positioning in table

partnum (hexadecimal)

Partition number for the open resource (table/index)

ucount (decimal)

Number of user threads currently accessing this partition

ocount (decimal)

Number of times this partition was opened

lockmode (decimal)

Type of lock being held using one of the following coded values:

0 No locks
 1 Byte lock
 2 Intent shared lock
 3 Shared lock
 4 Shared lock by repeatable read (only on items)
 5 Update lock
 6 Update lock by repeatable read (only on items)
 7 Intent exclusive lock
 8 Shared, intent exclusive lock
 9 Exclusive lock
 10 Exclusive lock by repeatable read (only on items)
 11 Inserter's repeatable read test lock

onstat -g osi: Print operating system information

Use the **onstat -g osi** command to display information on your operating system resources and parameters, including shared memory and semaphore parameters, the amount of memory currently configured on the computer, and the amount of memory that is unused.

Example Output

The **onstat -g osi** command also displays statistics on the hardware processors on your computer.

Use this command when the server is not online.

```
Machine Configuration....
OS Name                Linux
OS Release             2.6.9-34.ELsmp
OS Node Name           idas
OS Version              #1 SMP
OS Machine              x86_64
Number of processors    4
Number of online processors 4
System memory page size 4096 bytes
System memory           7970 MB
System free memory      1536 MB
Number of open files per process 1024
shmmax                  33554432
shmmin                  1
shmids                  4096
shmNumSegs              2097152
semmap                  << UnSupported >>
semids                  128
semnum                  32000
semundo                 << UnSupported >>
semNumPerID             250
semops                  32
semUndoPerProc          << UnSupported >>
semUndoSize             20
semMaxValue             32767
```

Figure 21-78. **onstat -g osi** Command Output

onstat -g pos command: Print file values

Use the **onstat -g pos** command to display the values in the `$INFORMIXDIR/etc/.infos.DBSERVERNAME` file.

Syntax:

```
▶▶ onstat -g pos ◀◀
```

Example output

```
1 7 0 infos ver/size 3 264
2 1 0 snum 0 52564801 44000000 4139 demo_on
3 4 0 onconfig path /opt/IBM/informix/etc/onconfig.demo_on
4 5 0 host informixva
5 6 0 oninit ver IBM Informix Dynamic Server Version 11.70.UC2DE
6 8 0 sqlhosts path /data/IBM/informix/etc/sqlhosts.demos
7 3 -32767 sema 32769
8 2 -32768 shm 32768 52564801 44000000 114176000 R
9 2 1 shm 1 52564802 4ace3000 67108864 V
```

Figure 21-79. **onstat -g pos** command output

onstat -g ppd command: Print partition compression dictionary information

Use the **onstat -g ppd** command to display information about the active compression dictionaries that were created for compressed tables and table fragments. You can choose to print information for a particular numbered partition or for all open partitions.

The **onstat -g ppd** command prints the same information that the **syscompdicts_full** table and the **syscompdicts** view in the **sysmaster** database display. The only difference is that the **syscompdicts_full** table and the **syscompdicts** view display information about all compression dictionaries, not just the active dictionaries.

Syntax:

```
▶▶ onstat -g ppd partition number ◀◀  
                  0
```

If you specify a partition number, **onstat -g ppd** prints the partition profile for that partition. If you specify 0, this option prints profiles for all partitions.

Example output

Partition Compression Dictionary Info								
partnum	Version	DbNum	CrTS	CrLogID	CrLogPos	DrTS	DrLogID	DrLogPos
0x200002	1	2	1229018150	3	577560	0	0	0
0x200003	1	2	1229018150	3	606232	0	0	0
0x300002	1	3	1229018150	3	630808	0	0	0
0x400002	1	4	1229018150	3	655384	0	0	0
0x500002	1	5	1229018150	3	679960	0	0	0

Figure 21-80. **onstat -g ppd** Output

Output description

partnum

Partition number to which the compression dictionary applies

Version

Version of the code that is creating the compression dictionary

DbNum

Number of the dbspace that the dictionary resides in

CrTS Timestamp that shows when the dictionary was created

CrLogID

Unique ID for the logical log that was created when the dictionary was created

CrLogPos

Position within the logical log when the dictionary was created

DrTS Timestamp that shows when the dictionary was purged

DrLogID

Unique ID for the logical log that was created when the dictionary was purged

DrLogPos

Position within the logical log when the dictionary was purged

onstat -g ppf command: Print partition profiles

Use the **onstat -g ppf *partition_number*** command to display the partition profile for the specified partition number.

Use the **onstat -g ppf** or the **onstat -g ppf 0** command to display the profiles for all partitions. If the `TBLSPACE_STATS` configuration parameter is set to 0, then the **onstat -g ppf** command displays: Partition profiles disabled.

For more information on the **onstat -g ppf** command, see the *IBM Informix Performance Guide*.

Syntax:

```
▶▶ onstat -g ppf partition_number ▶▶
```

Example output

Partition profiles												
partnum	lkrqs	lkwts	dlks	touts	isrd	iswrt	isrwt	isdel	bfrd	bfwrt	seqsc	rhitratio
0x100001	0	0	0	0	0	0	0	0	0	0	0	0
0x100002	1506	0	0	0	416	4	0	4	1282	20	0	97
0x100003	15	0	0	0	5	0	0	0	20	0	0	75
0x1000a5	0	0	0	0	0	0	0	0	12	0	0	67
0x1000e3	4	0	0	0	1	0	0	0	4	0	0	25
0x200001	0	0	0	0	0	0	0	0	0	0	0	0
0x300001	0	0	0	0	0	0	0	0	0	0	0	0
0x400001	0	0	0	0	0	0	0	0	0	0	0	0

Figure 21-81. **onstat -g ppf** command output

Output description**partnum (hex)**

The partition number

lkrqs (decimal)

The number of lock requests for a partition

lkwts (decimal)

The number of lock waits for a partition

dlks (decimal)

The number of deadlocks for a partition

touts(decimal)

The number of remote deadlock timeouts for a partition

isrd (decimal)

The number of read operations for a partition

iswrt (decimal)

The number of write operations for a partition

isrwt (decimal)

The number of rewrite or update operations for a partition

isdel (decimal)

The number of delete operations for a partition

bfrd (decimal)

The number of buffer read operations, in pages

bfwrt (decimal)

The number of buffer write operations, in pages

seqsc (decimal)

The number of sequential scans for a partition

rhitratio (percentage)

The ratio of disk read operations to buffer read operations

onstat -g pqs command: Print operators for all SQL queries

Use the **onstat -g pqs** command to display information about the operators used in all of the SQL queries that are currently running.

You can use this command to troubleshoot an application, to find which operators are running for the query and for how long, and how many rows each operator returns. While the EXPLAIN file contains information that will give you a general sense of the query plan, the **onstat -g pqs** command displays the runtime operator information for the query and the query plan.

Syntax:

```
▶▶ onstat -g pqs [sessionid] ▶▶
```

You can specify one of the following invocations:

Table 21-25. Descriptions of each **onstat -g pqs** command invocation

Invocation	Explanation
onstat -g pqs	Displays a one-line summary for each session.
onstat -g pqs sessionid	Displays information for the session that you specify.

Example output

The following example shows the results when three separate SQL statements are run in different sessions. The statements are:

```
select * from syscolumns;
select * from systables a, systables b;
update t1 set rowsize = rowsize +100;
```

```

Query Operators:
addr    ses-id  opname  phase  rows  time           in1      in2      stmt-type
ae50b3a 23      scan    open   0      00:00.00      0        0        SELECT
af269d0 5        nljoin  next   224717 00:01.82      af26a90  aeb4478  SELECT
af26a90 5        scan    next   472    00:00.20      0        0        SELECT
aeb4478 5        scan    next   50     00:01.63      0        0        SELECT
ad3c530 26      scan    open   0      00:00.00      0        0        UPDATE (a11)

```

Figure 21-82. **onstat -g pqs** command output

Output description

addr The address of the operator in memory. You can use this address to track which SCAN operator belongs to each JOIN operator.

ses-id The session ID in which the SQL statement was run.

opname
The name of the operator.

phase The phase in which the operator was used. For example OPEN, NEXT, CLOSE.

rows The number of rows that are processed by the operator.

time The amount of time to process the operator. The time is displayed to the millisecond. A time of 01:20.10 is 1 minute, 20 seconds, and 10 milliseconds.

in1 The first (outer) operator in the join.

in2 The second (inner) operator in the join.

stmt-type
The type of SQL statement, such as SELECT, UPDATE, DELETE.

onstat -g prc command: Print sessions using UDR or SPL routine

Use the **onstat -g prc** command to display the number of sessions that are currently using the UDR or SPL routine.

Syntax:

▶▶ onstat -g prc ◀◀

Example output

```

Stored Procedure Cache:
  Number of lists      : 31
  PC_POOLSIZE         : 50
  Number of entries    : 0
  Number of inuse entries : 0
Stored Procedure Cache Entries:
list# id ref_cnt  dropped?  heap_ptr  procedure name
-----
Stored Procedure Cache is empty.

```

Figure 21-83. **onstat -g prc** command output

onstat -g proxy command: Print proxy distributor information

Use the **onstat -g proxy** command to display information about proxy distributors. The output of the **onstat -g proxy** command differs slightly depending on whether the command is run on a primary server or on a secondary server.

Syntax:

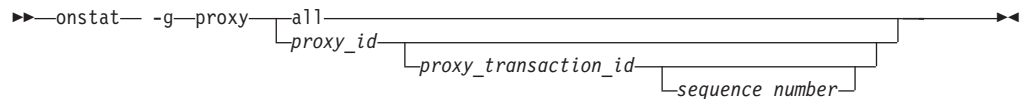

Invocation	Explanation
onstat -g proxy	Displays proxy distributor information
onstat -g proxy all	When run on the primary server, displays information about proxy distributors and proxy agent threads. When run on the secondary server, displays information about all sessions currently performing updates to secondary servers.
onstat -g proxy proxy_id proxy_transaction_id sequence_number	This option is valid only on secondary servers. Displays detailed information about the current work being performed by a given proxy distributor. The <i>proxy_transaction_id</i> and <i>sequence_number</i> are optional parameters. When supplied, the first number is considered the <i>proxy_transaction_id</i> , and the second is interpreted as the <i>sequence_number</i> . If the supplied <i>proxy_transaction_id</i> or <i>sequence_number</i> do not exist, the command output is the same as the output for onstat -

Example output using the onstat -g proxy command on a primary server

Secondary Node	Proxy ID	Reference Count	Transaction Count	Hot Row Total
nagpur_sdc1	2619	0	2	0
nagpur_c2	2632	0	1	0
nagpur_sec	2633	0	1	0 I

Figure 21-84. **onstat -g proxy** command output (run from primary server)

Output description

Secondary Node

Name of the secondary server as it is known by the primary server.

Proxy ID

ID of the proxy distributor. Proxy IDs are unique within a high-availability cluster.

Reference Count

Indicates the number of threads that are using the information for the current transaction. When the count becomes 0, the transaction processing is complete (either successfully or unsuccessfully).

Transaction Count

The number of transactions currently being processed by the proxy distributor.

Hot Row Total

Total number of hot rows ever handled by the proxy distributor.

Example output using the `onstat -g proxy` command on a secondary server

Primary Node	Proxy ID	Reference Count	Transaction Count	Hot Row Total
nagpur	2619	5	2	0

Figure 21-85. `onstat -g proxy` command output (run from secondary server)

Output description

Primary Node

Name of the primary server.

Proxy ID

ID of the proxy distributor. Proxy IDs are unique within a high-availability cluster.

Reference Count

Indicates the number of threads that are using the information for the current transaction. When the count becomes 0, the transaction processing is complete (either successfully or unsuccessfully).

Transaction Count

The number of transactions currently being processed by the proxy distributor.

Hot Row Total

Total number of hot rows ever handled by the proxy distributor.

Example output using the `onstat -g proxy all` command on a primary server

Secondary Node	Proxy ID	Reference Count	Transaction Count	Hot Row Total
nagpur_sdc1	2619	0	2	0
nagpur_c2	2632	0	1	0
nagpur_sec	2633	0	1	0

TID	Flags	Proxy ID	Source SessID	Proxy TxnID	Current Seq	sqlerrno	iserrno
94	0x00000224	2619	21	1	29	0	0
95	0x00000224	2619	22	2	68	0	0
93	0x00000224	2632	21	2	2	0	0
91	0x00000224	2633	25	1	6	0	0

Figure 21-86. `onstat -g proxy all` command output (run from primary server)

Output description

Secondary Node

Name of the secondary server as it is known by the primary server.

Proxy ID

ID of the proxy distributor. Proxy IDs are unique within a high-availability cluster.

Reference Count

Indicates the number of threads that are using the information for the current transaction. When the count becomes 0, the transaction processing is complete (either successfully or unsuccessfully).

Transaction Count

The number of transactions currently being processed by the proxy distributor.

Hot Row Total

Total number of hot rows ever handled by the proxy distributor.

TID

ID of the proxy agent thread running on the primary server. This ID is created by the proxy distributor to handle work from the session on the secondary server.

Flags

Flags of the proxy agent thread.

Proxy ID

The ID of the proxy distributor on behalf of which the proxy agent thread (TID) is running.

Source SessID

The ID of the user's session on the secondary server.

Proxy TxnID

The number of the current transaction. These numbers are unique to the proxy distributor.

Current Seq

The sequence number of the current operation in the current transaction.

sqlerrno

The error number of any SQL error (or 0 if no errors).

iserrno

The error number of any ISAM or RSAM error (or 0 if no errors).

Example output using the onstat -g proxy all command on a secondary server

Primary Node	Proxy ID	Reference Count	Transaction Count	Hot Row Total
nagpur	2619	5	2	0

Session	Session Ref	Proxy Proxy_id	Proxy TID	Proxy TxnID	Current Seq	Pending Ops	Reference Count
21	2	2619	94	1	29	1	1
22	2	2619	95	2	68	1	1

Figure 21-87. onstat -g proxy all command output (run from secondary server)

Output description

Primary Node

Name of the primary server.

Proxy ID

ID of the proxy distributor. Proxy IDs are unique within a high-availability cluster.

Reference Count

Indicates the number of threads that are using the information for the current transaction. When the count becomes 0, the transaction processing is complete (either successfully or unsuccessfully).

Transaction Count

The number of transactions currently being processed by the proxy distributor.

Hot Row Total

Total number of hot rows ever handled by the proxy distributor. A hot row is a row on a secondary server that is updated multiple times by more than one client. When a row is updated multiple times, the secondary server reads the before image from the primary server by placing an update lock on the row if the most recent update operation from a different session is not replayed on the secondary server.

Session The session ID

Proxy ID

The ID of the proxy distributor on behalf of which the proxy agent thread (TID) is running.

Proxy TID

Transaction ID of the proxy agent thread running on the primary server. This ID is created by the proxy distributor to handle work from the secondary server session.

Proxy TxnID

The number of the current transaction. These numbers are unique to the proxy distributor.

Current Seq

The sequence number of the current operation in the current transaction.

Pending Ops

The number of operations buffered on the secondary server that have not yet been sent to the primary server.

Reference Count

Indicates the number of threads that are using the information for the current transaction. When the count becomes 0, the transaction processing is complete (either successfully or unsuccessfully).

Example output using the *proxy_id* option on a secondary server

This command returns information only on a secondary server.

Proxy TxnID	Reference Count	Pending Ops	ProxySID
1	1	1	3
2	1	1	4

Figure 21-88. `onstat -g proxy proxy_id` command output (run from secondary server)

Output description

Proxy TxnID

The number of the current transaction. These numbers are unique to the proxy distributor.

Reference Count

Indicates the number of threads that are using the information for the current transaction. When the count becomes 0, the transaction processing is complete (either successfully or unsuccessfully).

Pending Ops

The number of operations buffered on the secondary server that have not yet been sent to the primary server.

Proxy SID

Proxy session ID.

Example output using the *proxy_id proxy_transaction_id* options on a secondary server

This command returns information only on a secondary server.

Sequence Number	Operation Type	rowid	Table Name	sqlerrno
28	*Update	526	stores_demo:nilesho.customer	0

Figure 21-89. `onstat -g proxy_id proxy_transaction_id` command output (run from secondary server)

Output description

Sequence Number

The number of the operation.

Operation Type

The type of operation to be performed. One of: Insert, Update, Delete, Other.

rowid The row ID of the row in which to apply the operation.

Table Name

The full table name, trimmed to fit a reasonable length. Format: database.owner.tablename

sqlerrno

The error number of any SQL error (or 0 if no errors).

Example output using the *proxy_id proxy_transaction_id sequence_number* options on a secondary server

This command returns information only on a secondary server.

The output fields are the same as the output fields displayed for the `onstat -g proxy_id proxy_transaction_id` command. While the `onstat -g proxy_id proxy_transaction_id` command displays details for a transaction, the `onstat -g proxy_id proxy_transaction_id sequence_number` displays details for all transaction operations.

```

s
Proxy Reference Pending ProxySID
TxnID Count Ops
61 0 3 22

onstat -g proxy 2788 61

Sequence Operation rowid Table sqlerrno
Number Type Name
960 Update 264 stores_demo:nilesho.customer 0
961 Update 265 stores_demo:nilesho.orders 0
962 Update 266 stores_demo:nilesho.items 0

onstat -g proxy 2788 61 962

Sequence Operation rowid Table sqlerrno
Number Type Name
962 Update 266 stores_demo:nilesho.items 0

```

Figure 21-90. `onstat -g proxy_id proxy_transaction_id sequence_number` command output (run from secondary server)

onstat -g que command: Prints ER queue statistics

Use the `onstat -g que` command to display statistics that are common to all queues in Enterprise Replication.

The queuer manages the logical aspects of the queue. The RQM (reliable queue manager) manages the physical queue.

The `onstat -g que` command is used primarily as a debugging tool and most often by Technical Support.

Syntax:

►► onstat -g que ◀◀

Example output

In the following example, **Element high water mark** shows the maximum size of the transaction buffer header data (metadata) allowed in memory, shown in kilobytes. **Data high water mark** shows the maximum size of transactions for user data allowed in memory, shown in kilobytes.

```

CDR Queuer Statistics:
  Queuer state      : 2
  Local server     : 100
  Element high water mark : 131072
  Data high water mark : 131072
  # of times txns split : 0
  Total # of split txns : 0
  allowed log delta : 30
  maximum delta detected : 4
  Control Key      : 0/00000007
  Synchronization Key : 0/00000003
Replay Table:
  Replay Posn (Disk value): 12/00000018 (12/00000018)
  Replay save interval   : 10
  Replay updates         : 10
  Replay # saves         : 17
  Replay last save time  : (1095118157) 2004/09/13 18:29:17
Send Handles
  Server ID          : 200
  Send state,count   : 0,0
  RQM hdl for trg_send: Traverse handle (0xaf8e018) for thread CDRACK_0 at Head_of_Q,
    Flags: None
  RQM hdl for control_send: Traverse handle (0xaf74018)
    for thread CDRACK_0 at Head_of_Q, Flags: None
  RQM hdl for sync_send: Traverse handle (0xadc6018) for thread CDRACK_0 at Head_of_Q,
    Flags: None
  Server ID          : 200
  Send state,count   : 0,0
  RQM hdl for trg_send: Traverse handle (0xac8b018) for thread CDRACK_1 at Head_of_Q,
    Flags: None
  RQM hdl for control_send: Traverse handle (0xb1ce018) for thread CDRACK_1 at Head_of_Q,
    Flags: None
  RQM hdl for sync_send: Traverse handle (0xadc5018) for thread CDRACK_1 at Head_of_Q,
    Flags: None
  Server ID          : 200
  Send state,count   : 0,0
  RQM hdl for trg_send: Traverse handle (0xaea71d8) for thread CDRNsA200 at Head_of_Q,
    Flags: None
  RQM hdl for ack_send: Traverse handle (0xae8c1d8) for thread CDRNsA200 at Head_of_Q,
    Flags: None
  RQM hdl for control_send: Traverse handle (0xae9e1d8) for thread CDRNsA200 at Head_of_Q,
    Flags: None

```

Figure 21-91. `onstat -g que` command output

onstat -g qst command: Print wait options for mutex and condition queues

Use the `onstat -g qst` command to display the wait statistics for mutex queues and condition queues (queues of waiters for a mutex or a condition).

The `QSTATS` configuration parameter must be set to 1 to enable the collection of statistics. For more information, see “`QSTATS` Configuration Parameter” on page 1-116.

Syntax:

```

▶▶ onstat -g qst ◀◀

```

Example output

```
Mutex Queue Statistics
name      nwaits   avg_time max_time avgq maxq nservs   avg_time
ddh chai 1      1354863 1354863 1    1    56      1690

Condition Queue Statistics
name      nwaits   avg_time max_time avgq maxq nservs   avg_time
arrived  1      110008  110008  1    1    0        0
logbf0   21      642    4431   1    2    0        0
logbf1   15      475    2519   1    2    0        0
logbf2   19      596    3274   1    2    0        0
bp_cond  1        0      0       1    1    0        0
```

Figure 21-92. `onstat -g qst` command output

Output description

name (string)

Name of the mutex or condition resource being waited for

nwaits (decimal)

Number of times this resource was waited for

avg_time (decimal)

Average time spent waiting (in microseconds)

max_time (decimal)

Maximum time spent waiting (in microseconds)

avgq (decimal)

Average length of the queue

maxq (decimal)

Maximum length of the queue

nservs (decimal)

Number of times this resource was acquired

avg_time (decimal, microsecond)

Average time the resource was held per acquisition (in microseconds)

onstat -g rah command: Print read-ahead request statistics

Use the `onstat -g rah` command to display information about read-ahead requests.

Syntax:

▶▶—onstat— -g—rah—————▶▶

Example output

```

Read Ahead
# threads          4
# Requests         150501
# Continued        1017
# Memory Failures  0
Q depth           0
Last Thread Add   04/06/2011.14:34

Partition ReadAhead Statistics

      Buffer  Disk   Hit   Data   Index   Idx/Dat
Partnum Reads  Reads Ratio # Reqs  Eff  # Reqs  Eff  # Reqs  Eff
0x200003 2412176 587381 75    0      0    150499 67    0      0

```

Figure 21-93. `onstat -g rah` command output

Output description

threads

Number of read-ahead threads

Requests

Number of read-ahead requests

Continued

Number of times a read-ahead request continued to occur

Memory Failures

Number of failed requests because of insufficient memory

Q Depth

Depth of request queue

Last Thread Add

Date and time when the last read-ahead thread was added

Partnum

Partition number

Buffer reads

Number of bufferpool and disk pages that were read

Disk Reads

Number of pages that were read from disk

Hit Ratio

Cache hit ratio for the partition

Reqs

Number of data page read ahead requests. (There are three instances of this output field: for data, the index, and index data.)

Eff

Efficiency of the read-ahead requests. This is the ratio between the number of pages requested by read-ahead operations to the number of pages that were already cached and for which a read-ahead operations was not needed. Values are between 0 and 100. A higher number means that read ahead is beneficial. (There are three instances of this output field: for data, for the index, and for index data.)

onstat -g rbm command: Print a block map of shared memory

Use the `onstat -g rbm` command to display a hexadecimal bitmap of the free and used blocks within the resident segment of shared memory.

Syntax:

```
▶▶ onstat -g rbm ◀◀
```

Example output

```
Block bitmap for resident segment address 0x44000000:  
address = 0x440003bc, size(bits) = 3035  
used = 3031, largest_free = 4  
  
0:ffffffff ffffffff ffffffff ffffffff ffffffff ffffffff ffffffff ffffffff  
256:ffffffff ffffffff ffffffff ffffffff ffffffff ffffffff ffffffff ffffffff  
512:ffffffff ffffffff ffffffff ffffffff ffffffff ffffffff ffffffff ffffffff  
768:ffffffff ffffffff ffffffff ffffffff ffffffff ffffffff ffffffff ffffffff  
1024:ffffffff ffffffff ffffffff ffffffff ffffffff ffffffff ffffffff ffffffff  
1280:ffffffff ffffffff ffffffff ffffffff ffffffff ffffffff ffffffff ffffffff  
1536:ffffffff ffffffff ffffffff ffffffff ffffffff ffffffff ffffffff ffffffff  
1792:ffffffff ffffffff ffffffff ffffffff ffffffff ffffffff ffffffff ffffffff  
2048:ffffffff ffffffff ffffffff ffffffff ffffffff ffffffff ffffffff ffffffff  
2304:ffffffff ffffffff ffffffff ffffffff ffffffff ffffffff ffffffff ffffffff  
2560:ffffffff ffffffff ffffffff ffffffff ffffffff ffffffff ffffffff ffffffff  
2816:ffffffff ffffffff ffffffff ffffffff ffffffff ffffffff ffffffffe00
```

Figure 21-94. `onstat -g rbm` command output

Output description

Header

address (hex)

In-memory starting address of the used/free blocks in the segment

size (bits)

Number of bits in the block bitmap; each bit represents one block

used (blocks)

Used blocks in the bitmap

largest_free (blocks)

Largest run of free blocks

Data

Bit number (decimal): data (hex)

Bit number followed by 32 bytes of data (hex)

onstat -g rcv command: Print ER receive manager statistics

Use the `onstat -g rcv` command to display statistics for transactions of the Receive Manager in Enterprise Replication.

The Receive Manager is a set of service routines that pass information between the receive queues and data sync threads.

The `onstat -g rcv` command is used primarily as a debugging tool and by Technical Support. If you suspect that acknowledgment messages are not being applied, you can use this option to check.

Syntax:

► onstat -g rcv server_id full ◄

The **onstat -g rcv** command has the following formats:

```
onstat -g rcv
onstat -g rcv server_id
onstat -g rcv full
```

The *server_id* modifier causes the command to print only those output messages received from the replication server whose group ID is *server_id*. The **full** modifier causes the command to print all statistics.

Example output

The following example shows output for the **onstat -g rcv full** command.

```

Receive Manager global  block 0D452018
  cdrRM_inst_ct:          5
  cdrRM_State:           00000000
  cdrRM_numSleepers:     3
  cdrRM_DsCreated:       3
  cdrRM_MinDSThreads:    1
  cdrRM_MaxDSThreads:    4
  cdrRM_DSBlock:         0
  cdrRM_DSParallelPL:    0
  cdrRM_DSFailRate:      0.000000
  cdrRM_DSNumRun:        35
  cdrRM_DSNumLockTimeout 0
  cdrRM_DSNumLockRB:     0
  cdrRM_DSNumDeadLocks  0
  cdrRM_DSNumPCommits    0
  cdrRM_ACKwaiting       0
  cdrRM_totSleep:        77
  cdrRM_Sleeptime:       153
  cdrRM_Workload:         0
  cdrRM_optscale:         4
  cdrRM_MinFloatThreads: 2
  cdrRM_MaxFloatThreads: 7
  cdrRM_AckThreadCount:  2
  cdrRM_AckWaiters:      2
  cdrRM_AckCreateStamp:  Wed Sep 08 11:47:49 2004
  cdrRM_DSCreateStamp:   Wed Sep 08 14:16:35 2004
  cdrRM_acksInList:      0
  cdrRM_BlobErrorBufs:   0

Receive Parallelism Statistics
Srvr Tot.Txn. Pending Active MaxPnd MaxAct AvgPnd AvgAct CommitRt
  1   35      0      0    21     3    7.00   1.63   0.00
  5    3      0      0     1     1    1.00   1.00   0.02
  6    6      0      0     1     1    1.00   1.00   0.21
Tot Pending:0 Tot Active:0 Avg Pending:5.77 Avg Active:1.50
Commit Rate:0.01

Time Spent In RM Parallel Pipeline Levels
Lev. TimeInSec Pcnt.
  0    17405 100.00%
  1      0  0.00%
  2      0  0.00%

Statistics by Source
Server 1
Repl Txn Ins Del Upd Last Target Apply Last Source Commit
65541 23  0  1 616 2004/09/08 14:20:15 2004/09/08 14:20:15
65542 11  0  0 253 2004/09/08 14:19:33 2004/09/08 14:19:33
65545  1  0  67  0 2004/09/08 14:20:37 2004/09/08 14:20:37
Server 5
Repl Txn Ins Del Upd Last Target Apply Last Source Commit
65541  3  0  0  81 2004/09/08 16:36:10 2004/09/08 16:36:09
Server 6
Repl Txn Ins Del Upd Last Target Apply Last Source Commit
65548  6  0  0  42 2004/09/08 16:37:59 2004/09/08 16:37:58

```

Figure 21-95. **onstat -g rcv full** command output

Fields in the Receive Manager global section

The **onstat -g rcv** command includes the Receive Manager global section. In this section, the following fields have the meanings shown:

Field	Description
cdrRM_DSParallelPL	Shows the current level of Apply Parallelism, 0 (zero) being the highest
cdrRM_DSNumLockTimeout cdrRM_DSNumLockRB cdrRM_DSNumDeadLocks	Indicate the number of collisions between various apply threads
cdrRM_acksinList	Shows acknowledgments that have been received but not yet processed

Fields in the Receive Parallelism Statistics section

The **onstat -g rcv** command includes the Receive Parallelism Statistics section, a summary of the data sync threads by source server.

Field	Description
Server	Source server ID
Tot.Txn.	Total number of transactions applied from this source server
Pending	Number of current transactions in the pending list for this source server
Active	Number of current transactions currently being applied from this source server
MaxPnd	Maximum number of transactions in the pending list queue
MaxAct	Maximum number of transaction in the active list queue
AvgPnd	Average depth of the pending list queue
AvgAct	Average depth of the active list queue
CommitRt	Commit rate of transaction from this source server based on transactions per second

Output in the Statistics by Source section

The Statistics by Source section of the **onstat -g rcv** command shows the following information for each source server. For each replicate ID:

- The number of transactions applied from the source servers
- The number of inserts, deletes, and updates within the applied transactions
- The timestamp of the most recently applied transaction on the target server
- The timestamp of the commit on the source server for the most recently applied transaction

onstat -g rea command: Print ready threads

Use the **onstat -g rea** command to display information about the virtual processor threads whose current status is ready.

Syntax:

```
▶▶ onstat -g rea ◀◀
```

Example output

```

Ready threads:
tid    tcb      rstcb  prty   status  vp-class  name
6      536a38  406464 4      ready   3cpu     main_loop()
28     60cfe8  40a124 4      ready   1cpu     onmode_mon
33     672a20  409dc4 2      ready   3cpu     sqlexec

```

Figure 21-96. **onstat -g rea** command output

onstat -g rep command: Print ER schedule manager events

Use the **onstat -g rep** command to display information about events that are in the queue for the Schedule Manager for Enterprise Replication.

The **onstat -g rep** command *n* is used primarily as a debugging tool and most often by Technical Support.

Syntax:

```

▶▶ onstat -g rep replname ▶▶

```

The **onstat -g rep** command has the following formats:

```

onstat -g rep
onstat -g rep replname

```

The *repl_name* modifier limits the output to those events originated by the replicate named *repl_name*.

Example output

The following example shows sample output for the **onstat -g rep** command.

```

Schedule manager Cb: add7e18 State: 0x8100 <CDRINIT,CDRRUNNING>
Event      Thread      When
=====
CDRDS      CDREvent    00:00:20

```

Figure 21-97. **onstat -g rep** command output

onstat -g rqm command: Print low-level queue statistics

Use the **onstat -g rqm** commands to display statistics and the contents of the low-level queues (send queue, receive queue, ack send queue, sync send queue, and control send queue) that are managed by the Reliable Queue Manager (RQM) in Enterprise Replication.

The RQM manages the insertion and removal of items to and from the various queues. The RQM also manages spooling of the in-memory portions of the queue to and from disk. The **onstat -g rqm** command displays the contents of the queue, size of the transactions in the queue, how much of the queue is in memory and on disk, the location of various handles to the queue, and the contents of the various progress tables. You can choose to print information for all queues or for just one queue by using one of the modifiers described below.

If a queue is empty, no information is printed for that queue.

Syntax:

```
▶▶ onstat -g rqm modifier ▶▶
```

The **onstat -g rqm** command has the following formats:

```
onstat -g rqm  
onstat -g rqm modifier
```

The following table describes the values for *modifier*.

Modifier	Action
ACKQ	Prints the ack send queue
BRIEF	Prints a brief summary of the number of transactions in each of the queues and the replication servers for which the data is queued. Use this modifier to quickly identify sites where a problem exists. If large amounts of data are queued for a single server, then that server is probably down or off the network.
CNTRLQ	Prints the control send queue
FULL	Prints full information about every in-memory transaction for every queue
RECVQ	Prints the receive queue
SBSPACES	Prints information about the sbspaces configured for ER
SENDQ	Prints the send queue
SYNCQ	Prints the sync send queue
VERBOSE	Prints all the buffer headers in memory

When you specify a modifier to select a specific queue, the command prints all the statistics for that queue and information about the first and last in-memory transactions for that queue.

The other modifiers of the **onstat -g rqm** command are used primarily as a debugging tool and most often by Technical Support.

Output sections for the SENDQ modifier

The output for the SENDQ modifier contains the following sections:

- RQM Statistics for Queue—a summary of current and historical information for the queue. This includes the number of transactions in the queue, how many are spooled, how many bytes they are using, some maximum statistics, and the high water marks that will trigger stably storing transactions in the **syscdr** tables.
- First Txn—information about the first transaction in the queue. To check if the queue is draining, you can run the **onstat -g rqm** command several times and see if the first transaction's RQM key is changing. The RQM key has the following format: *Server_ID/Commit_unique_logID/Commit_log_position/Sequence*. If it is not draining, the target server may be offline or some other problem is occurring. The NeedAck field shows from which server the transaction is waiting for an acknowledgment. You can use this bitmap mask with the output from the **onstat -g cat** command to determine the name of the server which server Enterprise Replication is waiting on for an acknowledgment.

- Last Txn—information about the last transaction in the queue
- Traverse handle—lists the handles used for threads
- Progress table—provides information about the progress of each replicate under the headers: Server, Group, Bytes Queued, Acked, and Sent. The Group field shows the replicate ID. The Acked field shows what has been acknowledged. The Sent field shows which entries are now in transit. Both the Acked and the Sent field show the RQM key, which has the following format:
Server_ID/Commit_unique_logID/Commit_log_position/Sequence.

Example output

The following example shows output for the **onstat -g rqm SENDQ** command.

```
RQM Statistics for Queue (0x0D3DF018) trg_send
Transaction Spool Name: trg_send_stxn
Insert Stamp: 35/0
Flags: SEND_Q, SPOOLED, PROGRESS_TABLE, NEED_ACK
Txns in queue:          35
Log Events in queue:    0
Txns in memory:         35
Txns in spool only:     0
Txns spooled:           0
Unspooled bytes:        176206
Size of Data in queue:  176206 Bytes
Real memory in use:     176206 Bytes
Pending Txn Buffers:    0
Pending Txn Data:       0 Bytes
Max Real memory data used: 176206 (2457600) Bytes
Max Real memory hdrs used 65988 (2457600) Bytes
Total data queued:      176206 Bytes
Total Txns queued:      35
Total Txns spooled:     0
Total Txns restored:    0
Total Txns recovered:   0
Spool Rows read:        0
Total Txns deleted:     0
Total Txns duplicated:  0
Total Txn Lookups:      363

First Txn (0x0D60C018) Key: 1/9/0x000d4bb0/0x00000000
Txn Stamp: 1/0, Reference Count: 0.
Txn Flags: Notify
Txn Commit Time: (1094670993) 2004/09/08 14:16:33
Txn Size in Queue: 5908
First Buf's (0x0D31C9E8) Queue Flags: Resident
First Buf's Buffer Flags: TRG, Stream
NeedAck: Waiting for Acks from <[0004]>
No open handles on txn.

Last Txn (0x0D93A098) Key: 1/9/0x00138ad8/0x00000000
Txn Stamp: 35/0, Reference Count: 0.
Txn Flags: Notify
Txn Commit Time: (1094671237) 2004/09/08 14:20:37
Txn Size in Queue: 6298
First Buf's (0x0D92FFA0) Queue Flags: Resident
First Buf's Buffer Flags: TRG, Stream
NeedAck: Waiting for Acks from <[0004]>

Traverse handle (0x0D045018) for thread CDRNsA3 at txn (0x0D93A098)
End_of_Q,Flags: None
Traverse handle (0x0D08E018) for thread CDRNsA4 at txn (0x0D93A098)
End_of_Q,Flags: None
Traverse handle (0x0D523018) for thread CDRNsA5 at txn (0x0D93A098)
End_of_Q,Flags: None
Traverse handle (0x0D0D9018) for thread CDRNsA6 at txn (0x0D93A098)
End_of_Q,Flags: None
```

```

Traverse handle (0x0D4041D8) for thread CDRNsA2 at Head_of_Q,Flags: None
Traverse handle (0x0D3F01D8) for thread CDRNrA2 at Head_of_Q, Flags: None
Traverse handle (0x0D045018) for thread CDRNsA3 at txn (0x0D93A098)
End_of_Q,Flags: None
Traverse handle (0x0D31C018) for thread CDRNrA3 at Head_of_Q, Flags: None
Traverse handle (0x0D08E018) for thread CDRNsA4 at txn (0x0D93A098)
End_of_Q,Flags: None
Traverse handle (0x0D4C8018) for thread CDRNrA4 at Head_of_Q, Flags: None
Traverse handle (0x0D523018) for thread CDRNsA5 at txn (0x0D93A098)
End_of_Q,Flags: None
Traverse handle (0x0D57F018) for thread CDRNrA5 at Head_of_Q, Flags: None
Traverse handle (0x0D0D9018) for thread CDRNsA6 at txn (0x0D93A098)
End_of_Q,Flags: None

```

```

Server      Group Bytes Queued      Acked      Sent
-----
 6 0x10009          0 1/9/138ad8/0 - 1/9/138ad8/0
 5 0x10009          0 1/9/138ad8/0 - 1/9/138ad8/0
 4 0x10009          0 1/9/138ad8/0 - 1/9/138ad8/0
 3 0x10009          0 1/9/138ad8/0 - 1/9/138ad8/0
 2 0x10009      4154 efffffff/fffffff/fffffff/fffffff - 1//138ad8/0
 6 0x10006          0 1/9/12d8f8/0 - 1//12d8f8/0
 5 0x10006          0 1/9/12d8f8/0 - 1//12d8f8/0
 4 0x10006          0 1/9/12d8f8/0 - 1/9/12d8f8/0
 3 0x10006          0 1/9/12d8f8/0 - 1/9/12d8f8/0
 2 0x10006      31625 efffffff/fffffff/fffffff/fffffff - 1/9/12d8f8/0

```

onstat -g rss command: Print RS secondary server information

Use the **onstat -g rss** commands to display information about remote standalone secondary servers.

Syntax:

```

▶▶ onstat -g rss
    -verbose
    -log
    -server_name

```

The output of the **onstat -g rss** command differs slightly depending on whether the command is run on the primary server or on the RS secondary server.

Invocation	Explanation
onstat -g rss	Displays brief RS secondary server information
onstat -g rss verbose	Displays detailed RS secondary server information
onstat -g rss log	Displays log information. This command is only applicable when run on the primary server.
onstat -g rss server_name	Displays information about a specific RS secondary server. This command is only applicable when run on the primary server.

Example output (primary server)

```

Local server type: Primary
Index page logging status: Enabled
Index page logging was enabled at: 2009/08/31 09:35:22
Number of RSS servers: 1

RSS Server information:

RSS Server control block: 0x5fdd9740
RSS server name: serv3
RSS server status: Active
RSS connection status: Connected
Log transmission status: Active
Next log page to send(log id,page): 53,117632
Last log page acked(log id,page): 53,115615
Time of Last Acknowledgment: 2009-08-31.14:14:09
Pending Log Pages to be ACKed: 1984
Approximate Log Page Backlog:97104
Sequence number of next buffer to send: 3676
Sequence number of last buffer acked: 3612
Supports Proxy Writes: Y

```

Figure 21-98. `onstat -g rss verbose` command output (run on primary server)

Output description (primary server)

Local server type

Primary or RSS (remote standalone secondary) server type

Index page logging status

Displays whether index page logging is enabled or disabled between primary server and secondary server

Index page logging was enabled at

Date and time that index page logging was enabled

Number of RSS servers

Number of RS secondary servers connected to the primary server

RSS Server control block

RS secondary server control block

RSS Server name

Name of RS secondary server

RSS Server status

Displays whether RS secondary server is active or not

RSS Connection status

Connection status of RS secondary server

Log transmission status

Displays whether log transmission is active or inactive

Next log page to send (log id, page)

The log ID and page number of the next log page that will be sent

Last log page acked (log id, page)

The log ID and page number of the last acknowledged log

Time of Last Acknowledgment

The time at which the last log was acknowledged

Pending Log pages to be ACKed

The number of logs sent but not yet acknowledged

Approximate Log Page Backlog

The difference between the number of logs that were sent and the end of the logical log

Sequence number of next buffer to send

The sequence number of the next buffer to be sent

Sequence number of last buffer acked

The sequence number of the last acknowledged buffer

Supports Proxy Writes

Displays whether the server is currently configured to allow updates to secondary servers. **Y** = supports updates to secondary servers, **N** = does not support updates to secondary servers.

Example output (RS secondary server)

```
Local server type: RSS
Server Status : Active
Source server name: cdr_ol_nag_1
Connection status: Connected
Last log page received(log id,page): 7,877
```

Figure 21-99. **onstat -g rss** command output (run on RS secondary server)

Output description (RS secondary server)

Local server type

Primary or RSS (remote standalone secondary) server type

Server Status

Displays whether RS secondary server is active

Source server name

Name of the primary server

Connection status

Connection status of RS secondary server

Last log page received (log id,page)

Most recent log ID and page received

Example output with log option (primary server)

```
Log Pages Snooped:
RSS Srv      From      From      Tossed
name         Cache     Disk      (LBC full)
cdr_ol_nag_1_c1  1368     1331     0
cdr_ol_nag_1_c2  1357     1342     0
cdr_ol_nag_1_c3  1356     1343     0
```

Figure 21-100. **onstat -g rss log** command output (run on primary server)

Output description with log option (primary server)

Log Pages Snooped

Statistics for each RS secondary server

RSS Srv name
RS secondary server name

From Cache
From cache number

From Disk
Log from disk

Tossed (LBC full)
Number of log pages discarded as a result of the LBC becoming full

onstat -g rwm command: Print read and write mutexes

Use the **onstat -g rwm** command to display information about read, write, and waiting mutex threads, and to list the addresses of the tickets that these threads have acquired.

Syntax:

▶▶ onstat -g rwm ◀◀

Example output

```

MUTEX  NAME      write/read/wait  tcb list
<address> <name>      first mutex
  Writer  ticket = <ticket address>  tcb=<thread address> <thread name>
  Readers ticket = <ticket address>  tcb=<thread address> <thread name>
  Waiters ticket = <ticket address>  tcb=<thread address> <thread name>
<address> <name>      second mutex
  Writer  ticket = <ticket address>  tcb=<thread address> <thread name>
  Readers ticket = <ticket address>  tcb=<thread address> <thread name>
  Waiters ticket = <ticket address>  tcb=<thread address> <thread name>
....
....
....
<address> <name>      last mutex
  Writer  ticket = <ticket address>  tcb=<thread address> <thread name>
  Readers ticket = <ticket address>  tcb=<thread address> <thread name>
  Waiters ticket = <ticket address>  tcb=<thread address> <thread name>

```

Figure 21-101. onstat -g rwm command output

Output description

tcb List of thread addresses

Writer List of write threads

Readers
List of read threads

Waiters
List of waiting threads

ticket Address of ticket acquired by the thread

onstat -g sch command: Print VP information

Use the **onstat -g sch** command to display information about thread migration and the number of semaphore operations, spins, and busy waits for each virtual processor.

Syntax:

▶▶ onstat -g sch ◀◀

Example Output

```
VP Scheduler Statistics:
vp  pid  class  semops  busy waits  spins/wait
1   3284  cpu    23997   0           0
2   1340  adm     0       0           0
3   4624  lio     2       0           0
4   3320  pio     2       0           0
5   6076  aio    7710    0           0
6   4580  msc     46      0           0
7   3428  soc     7       0           0
8   2308  soc     1       0           0

Thread Migration Statistics:
vp  pid  class  steal-at  steal-sc  idlvp-at  idlvp-sc  inl-polls  Q-ln
1   3284  cpu    0         0         0         0         0         0
2   1340  adm    0         0         0         0         0         0
3   4624  lio    0         0         0         0         0         0
4   3320  pio    0         0         0         0         0         0
5   6076  aio    0         0         0         0         0         0
6   4580  msc    0         0         0         0         0         0
7   3428  soc    0         0         0         0         0         0
8   2308  soc    0         0         0         0         0         0
```

Figure 21-102. **onstat -g sch** command output

onstat -g scn command: Print scan information

Use the **onstat -g scn** command to display the status of a current scan and information on the scan. The **onstat -g scn** command also identifies whether a scan is a light or bufferpool scan.

If you have a long-running scan, you might want to use this command to check the progress of the scan, to determine how long the scan will take before it completes, and to see whether the scan is a light scan or a bufferpool scan.

Syntax:

▶▶ onstat -g scn ◀◀

Example Output

```

Light Scan Info
descriptor  address          next_lpage  next_ppage      ppage_left  bufcnt  look_aside

RSAM batch sequential scan info

SesID Thread Partnum Rowid   Rows Scan'd Scan Type Lock Mode  Notes
48   68   10016e 12bb09 43146      Light   Table   Look aside,
40   47   100106 101     0          Buffpool +Test   Must copy

RSAM batch index scan info

SesID Thread Partnum Scan Type Lock Mode  Notes

```

Figure 21-103. **onstat -g scn** output

Output Description

descriptor (decimal)

Light scan ID

address (hex)

Memory address of the light scan descriptor

next_lpage (hex)

Next logical page address to scan

next_ppage (hex)

Next physical page address to scan

ppage_left (decimal)

Number of physical pages left to scan in the current extent

bufcnt Number of light scan buffers used for this light scan

look_aside

Whether look aside is needed for this light scan (Y = yes, N = no). Look asides occur when a thread needs to examine the buffer pool for existing pages to obtain the latest image of a page being light scanned.

SesID Session ID

Thread

Thread ID

Partnum

Partition number

Rowid

Current row ID

Rows Scan'd

Number of rows that have been scanned

Scan Type

Either:

- Bufferpool
- Light (light scan)

.

Lock Mode

The type of acquired lock or no lock:

- Table (table-level lock acquired)
- Slock (share locks acquired)

- Ulock (update locks acquired)
- blank (no locks acquired)

This column can also show one of the following values:

- +Test (The scan tested for a conflict with the specified lock type; the lock was not acquired.)
- +Keep (The acquired locks will be held until end of session instead of the end of the transaction.)

Notes This column can show one of the following values:

- Look aside

The light scan is performing look aside.

The light scan reads blocks of pages directly from disk into large buffers, rather than getting each page from the buffer manager. In some cases, this process requires the light scan to check the buffer pool for the presence of each data page that it processes from one of its large buffers; this process is called *look aside*. If the page is currently in the buffer pool, the light scan will use that copy instead of the one in the light scan large buffer. If the page is not in the buffer pool, the light scan will use the copy that the light scan read from disk into its large buffer. If the light scan is performing look aside, the performance of the scan is slightly reduced.

In many cases, the light scan can detect that it is impossible for the buffer pool to have a newer version of the page. In these situations, the light scan will not check the buffer pool, and the look aside note will be absent.

- Forward row lookup

The server is performing a light scan on a table that has rows that span pages. The light scan must access and use the buffer pool to get the remainder pieces of any rows that are not completely on the home page.

onstat -g sds command: Print SD secondary server information

Use the **onstat -g sds** command to display information about shared-disk secondary servers.

Syntax:

```

▶▶ onstat -g sds [verbose server_name]

```

The output of the **onstat -g sds** command differs slightly depending on whether the command is issued on the primary server or on the SD secondary server.

Invocation	Explanation
onstat -g sds	Displays brief SD secondary server information
onstat -g sds verbose	Displays detailed SD secondary server information
onstat -g sds server_name	Displays information about a specific SD secondary server. When <i>server_name</i> is specified, the command must be issued from the primary server.

Example output (primary server)

```
Local server type: Primary
Number of SDS servers:1

SDS server information

SDS srv      SDS srv      Connection    Last LPG sent  Supports
name         status       status        (log id,page)  Proxy Writes
C_151162    Active       Connected     554,4998      Y
```

Figure 21-104. **onstat -g sds** command output (run from primary server)

Output description (primary server)

Local server type

Primary or SDS (shared disk secondary) server type

Number of SDS servers

Number of SD secondary servers connected to the primary server

SDS Srv name

Name of SD secondary server

SDS Srv status

Displays whether SD secondary server is active

Connection status

Displays whether SD secondary server is connected

Last LPG sent (log id, page)

Most recent LPG log ID and page

Supports Proxy Writes

Displays whether the server is currently configured to allow updates to secondary servers. **Y** = supports updates to secondary servers, **N** = does not support updates to secondary servers.

Example output with verbose option (primary server)

```

Number of SDS servers:1
Updater node alias name :serv1

SDS server control block: 0x5fd51510
server name: serv2
server type: SDS
server status: Active
connection status: Connected
Last log page sent(log id,page):54,84732
Last log page flushed(log id,page):54,84732
Last log page acked (log id, page):54,84732
Last LSN acked (log id,pos):54,347062296
Approximate Log Page Backlog:0
Current SDS Cycle:2
Acked SDS Cycle:2
Sequence number of next buffer to send: 10
Sequence number of last buffer acked: 9
Time of lask ack:2009/08/31 14:16:11
Supports Proxy Writes: Y

```

Figure 21-105. **onstat -g sds verbose** command output (run from primary server)

Output description with verbose option (primary server)

Number of SDS servers

Number of attached SDS (shared disk secondary) servers

Updater node alias name

Name of primary server

SDS server control block

SD secondary server control block

server name

The name of the server

server type

The type of server

server status

Displays whether the server is active or inactive

connection status

Status of connection between primary and secondary server

Last log page sent (log id, page)

Log ID and page of most recent log page sent

Last log page flushed (log id, page)

Log ID and page of the most recent log page flushed

Last log page acked (log id, pos)

Most recent log page acknowledged

Last LSN acked (log id, pos)

Most recent log sequence number that was acknowledged

Approximate Log Page Backlog

The number of logs waiting to be sent

Current SDS Cycle

Used internally by IBM support to monitor coordination of the primary server with the SDS server

Acked SDS Cycle

Used internally by IBM support to monitor coordination of the primary server with the SDS server

Sequence number of next buffer to send

Sequence number of next buffer to send

Sequence number of last buffer acked

Sequence number of next buffer acknowledged

Time of last ack

Date and time of last log acknowledgment

Supports Proxy Writes

Displays whether the server is currently configured to allow updates to secondary servers. **Y** = supports updates to secondary servers, **N** = does not support updates to secondary servers.

Example output with verbose option (SD secondary server)

```
SDS server control block: 0xb299880
Local server type: SDS
Server Status : Active
Source server name: cdr_ol_nag_1
Connection status: Connected
Last log page received(log id,page): 7,884
Next log page to read(log id,page):7,885
Last LSN acked (log id,pos):7,3621272
Sequence number of last buffer received: 0
Sequence number of last buffer acked: 0
Current paging file:/work1/nagaraju/dbspaces/page_cdr_ol_nag_1_sdc1_
Current paging file size:2048
Old paging file:/work1/nagaraju/dbspaces/page_cdr_ol_nag_1_sdc1_
Old paging file size:10240
```

Figure 21-106. **onstat -g sds verbose** command output (run from SD secondary server)

Output description with verbose option (SD secondary server)

SDS server control block

SD secondary server control block

Local server type

Primary or SDS (shared disk secondary) server type

Server status

Displays whether SD secondary server is active

Source server name

Displays name of primary server

Connection status

Displays whether SD secondary server is connected

Last log page received (log id, page)

Most recent log page received

Next log page to read (log id,page)

Next log page in sequence to read

Last LSN acked (log id,pos)

Most recent LSN acknowledged

Sequence number of last buffer received
Sequence number of last buffer received

Sequence number of last buffer acked
Sequence number of last buffer acknowledged

Current paging file
Name of current paging file

Current paging file size
Size of current paging file

Old paging file
Name of previous paging file

Old paging file size
Size of previous paging file

onstat -g seg command: Print shared memory segment statistics

Use the **onstat -g seg** command to display the statistics for shared memory segments.

This command shows how many segments are attached and their sizes. For information about running the **onstat -g seg** command on a dump file created without the buffer pool, see “Running **onstat** Commands on a Shared Memory Dump File” on page 21-24.

Syntax:

▶▶ onstat -g seg ◀◀

Example output

id	key	addr	size	ovhd	class	blkused	blkfree
8945678	52604801	44000000	133652480	1006264	R	32627	3
8978447	52604802	4bf76000	131072000	769136	V	17181	14819
Total:	-	-	264724480	-	-	49808	14822

(* segment locked in memory)
Virtual segment low memory reserve (bytes):4194304
Low memory reserve used 0 times and used maximum block size 0 bytes

Figure 21-107. **onstat -g seg** command output

Output description

id The ID of the shared memory segment

key The shared memory key associated with the shared memory segment ID

addr The address of the shared memory segment

size The size of the shared memory segment in bytes

ovhd The size of the shared memory segment control information (overhead) in bytes

class The class of the shared memory segment (R is for Resident, V is for Virtual, VX is for Virtual Extended, and M is for Message.)

blkused

The number of blocks of used memory

blkfree

The number of blocks of free memory

Virtual segment low memory reserve (bytes)

The size of reserved memory for use when critical activities are needed and the server has limited free memory, specified in bytes (You specify reserved memory in the LOW_MEMORY_RESERVE configuration parameter.)

Low memory reserve used 0 times and used maximum block size 0 bytes)

The number times that the server has used the reserved memory and the maximum memory needed

Related reference:

“LOW_MEMORY_RESERVE configuration parameter” on page 1-92

“EXTSHMADD configuration parameter” on page 1-78

onstat -g ses command: Print session-related information

Use the **onstat -g ses** command to display information about the session.

By default, only the DBSA can view **onstat -g ses** syssqltrace information. However, when the UNSECURE_ONSTAT configuration parameter is set to 1, all users can view this information.

Syntax:

▶▶ onstat -g ses sessionid ▶▶

You can specify one of the following invocations.

Invocation

Explanation

onstat -g ses

Displays a one-line summary for each session

onstat -g ses sessionid

Displays information for a specific session

Example output for all sessions

session					#RSAM	total	used	dynamic
id	user	tty	pid	hostname	threads	memory	memory	explain
24	informix	-	0	-	0	12288	7936	off
23	informix	-	17602	carson	1	57344	48968	off
3	informix	-	0	-	0	12288	9168	off
2	informix	-	0	-	0	12288	7936	off

Figure 21-108. **onstat -g ses** command output

Example output for a specific session

```

session          effective          #RSAM   total   used   dynamic
id   user      user      tty  pid  hostname threads  memory  memory explain
53   informix -        36  18638 apollo11 1        73728  63048  off

Program :
/usr/informix/bin/dbaccess

tid   name      rstcb          flags   curstk   status
77    sqlxec    4636ba20      Y--P--- 4240    cond wait sm_read -

Memory pools      count 1
name      class addr          totalsize freesize  #allocfrag #freefrag
53        V      4841d040          73728   10680    84         6

name      free      used          name      free      used
overhead  0         3288          scb       0         144
opentable 0         2904          filetable 0         592
log        0         16536         temprec   0         2208
gentcb     0         1656          ostcb     0         2920
sqscb     0         21296         sql       0         72
hashfiletab 0         552          osenv     0         2848
sqtcb     0         7640          fragman   0         392

sqscb info
scb          sqscb          optofc   pdqpriority optcompind directives
481b70a0     483e2028      0        0             0           1

Sess      SQL          Current          Iso Lock      SQL  ISAM F.E.
Id        Stmt type    Database         Lvl Mode      ERR  ERR  Vers  Explain
53        -           sysmaster       CR  Not Wait    0    0    9.24 Off

Last parsed SQL statement :
Database 'sysmaster@1x1'

Xadatasources participated in this session :
Xadatasource name          RMID      Active
xabasicdb@atmo110:sitaramv.xads_t3_i1 6         YES
xabasicdb@atmo110:sitaramv.xads_t2_i1 4         YES
xabasicdb@atmo110:sitaramv.xads_t1_i3 3         YES
xabasicdb@atmo110:sitaramv.xads_t1_i2 2         YES
xabasicdb@atmo110:sitaramv.xads_t1_i1 1         YES
xabasicdb@atmo110:sitaramv.xads_t2_i2 5         NO

DRDA client info
Userid:
Wrkstnname: nemea
Applname: db2jcc_application
Acctng: JCC03510nemea
Programid:
Autocommit:
Packagepath:

```

Figure 21-109. `onstat -g sesssessionid` command output

Output description: session section

Session id

The session ID

user The username who started the session

tty The tty associated with the front end for this session

pid The process ID associated with the front end for this session

hostname The hostname from which this session has connected

#RSAM threads The number of RSAM thread allocated for this session

total memory The amount of memory allocated for this session

used memory The amount of memory actually used by this session

dynamic explain Generate explain output of the SQL statements of the session (on or off)

Output description: program section

Displays the full path of the client program that is used in your session. Use the client program information to monitor or stop access to the database.

Output description: threads section

Although this section has no title, the following output displays information about threads.

tid The thread ID

name The name of the thread

rstcb RSAM control block

flags Describes the status of the thread using the following codes:

Position 1

B Waiting on a buffer

C Waiting on a checkpoint

G Waiting on a logical-log buffer write

L Waiting on a lock

S Waiting on a mutex

T Waiting on a transaction

X Waiting on a transaction cleanup

Y Waiting on a condition

Position 2

*** An asterisk in this position means that the thread encountered an I/O failure in the middle of a transaction

Position 3

A Archive thread

B Begin work

P Begin Prepare or Prepared work

X XA prepared

C Committing or committed

R Aborting or aborted
H Heuristically aborted or heuristically rolling back

Position 4

P Primary thread

Position 5

R Reading

X Critical section

Position 6

R Recovery thread

Position 7

M Monitor thread

D Daemon thread

C Cleaner

F Flusher

B B-tree scanner

curstk Current stack size

status Current thread status

Output description: memory pools header section

The information is repeated for each session pool.

name Name of pool

class Class of the memory where the pool is allocated from. R is for Resident, V is for Virtual, and M is for Message

addr Address of the pool structure

totalsize

Total size of the memory acquired by the pool in bytes

reesize Number of bytes free in the pool

#allofrac

Number of allocated memory fragments in the pool

#freefrag

Number of free fragments in the pool

Output description: Memory pools section

name Name of a component which has allocated memory from the pool

free Number of bytes freed

used Number of bytes allocated

Output description: sqscb info section

scb The session control block. This is the address of the main session structure in shared memory

sqscb SQL level control block of the session

optofc The current value of the **OPTOFC** environment variable or ONCONFIG configuration file setting

pdqpriority
The current value of the **PDQPRIORITY** environment variable or ONCONFIG configuration file setting

optcompind
The current value of the **OPTCOMPIND** environment variable or ONCONFIG configuration file setting

directives
The current value of the **DIRECTIVES** environment variable or ONCONFIG configuration file setting

Output description: SQL section

Displays SQL information for the specified session. This section contains the same information that is output from the **onstat -g sql** command. See “**onstat -g sql** command: Print SQL-related session information” on page 21-172.

Output description: Last parsed SQL statement section

The Last parsed SQL statement section contains the same information that is output from the **onstat -g sql** command. See “**onstat -g sql** command: Print SQL-related session information” on page 21-172.

Output description: Xdatasources participated in this session section

The Xdatasources participated in this session section shows information about the XA data sources that are available during the session, their resource manager identifiers, and whether they are currently active.

Xdatasource name

The XA data source that participated in the session

RMID The identifier of the resource manager for the corresponding XA data source

Active Whether the XA data source is still active

Output description: DRDA client info section

The **DRDA client info** section shows information about Distributed Relational Database Architecture (DRDA) connections to clients.

Userid

User ID of the client user

Wrkstnname

Name of the client workstation

Applname

Name of the client application, for example db2jcc_application

Acctng

Accounting string from the client, for example JCC03510nemea

Programid

Client program identifier (not used by Informix)

Autocommit

Default transaction autocommit mode for Informix data sources

Packagepath

Client package path (not used by Informix)

onstat -g sle command: Print all sleeping threads

Use the `onstat -g sle` command to print all sleeping threads.

Syntax:

▶▶ onstat -g sle ◀◀

Example output

```
Current Admin VP sleep period: 10 millisecs
Sleeping threads with timeouts: 21 threads
```

tid	v_proc	rstcb	name	time
49	1	b3b13a8	onmode_mon	0.02
5	1	0	Cosvr Avail Mgr	0.05
42	1	b3ad028	main_loop()	0.08
9	3	b3ad6e8	xtm_svcc	0.64
14	5	0	mgmt_thd_5	0.65
13	4	0	mgmt_thd_4	0.65
4	1	0	mgmt_thd_1	0.65
6	3	0	dfm_svc	0.98
33	13	0	mgmt_thd_13	1.54
27	10	0	mgmt_thd_10	1.54
21	7	0	mgmt_thd_7	1.54
12	3	0	mgmt_thd_3	1.76
29	11	0	mgmt_thd_11	1.76
23	8	0	mgmt_thd_8	2.08
31	12	0	mgmt_thd_12	2.08
35	14	0	mgmt_thd_14	2.98
19	6	0	mgmt_thd_6	3.00
25	9	0	mgmt_thd_9	3.00
37	3	0	sch_rgm	3.48
44	5	b3af8a8	btscanner 0	7.31
46	3	b3b0628	bum_sched	41.26

Figure 21-110. `onstat -g sle` command output

onstat -g smb command: Print sbspaces information

Use the `onstat -g smb` command to display detailed information about sbspaces.

Syntax:

▶▶ onstat -g smb ◀◀

```

c
e
fdd
lod
s
h
  cad
  fdd
  lod
```

Command	Explanation
<code>onstat -g smb c</code>	Lists all the chunks in the sbspace.
<code>onstat -g smb e</code>	Lists the entries in the large object header table.
<code>onstat -g smb fdd</code>	Lists the smart-large-object file descriptors.
<code>onstat -g smb lod</code>	Lists the header and entries in the smart-large-object header table.
<code>onstat -g smb s</code>	Lists the sbspace attributes (owner, name, page size, -Df flag settings). Fields with a value of 0 or -1 were not initialized during sbspace creation.
<code>onstat -g smb h</code>	Lists the headers of all smart-large-object table types.
<code>onstat -g smb h cad</code>	Lists the header for the smart-large-object chunk adjunct table.
<code>onstat -g smb h fdd</code>	Lists the header for the smart-large-object file descriptor table.
<code>onstat -g smb h lod</code>	Lists the header for the smart-large-object header table.

Example output for the `onstat -g smb c` command

Use the `onstat -g smb c` command to monitor the amount of free space in each sbspace chunk, and the size in pages of the user data, metadata, and reserved areas. The `onstat -g smb c` command displays the following information for each sbspace chunk:

- Chunk number and sbspace name
- Chunk size and pathname
- Total user data pages and free user data pages
- Location and number of pages in each user-data and metadata areas

In the following example, chunk 2 of sbspace1 has 2253 original free pages (`orig fr`), 2253 user pages (`usr pgs`), and 2245 free pages (`free pg`). For the first user-data area (`Ud1`), the starting page offset is 53 and the number of pages is 1126. For the metadata area (`Md`), the starting page offset is 1179 and the number of pages is 194. For the reserved data (`Ud2`), the starting page offset is 1373 and the number of pages is 1127.

Chunk Summary:

```

sbnm 2 chunk 2
chunk:  address  flags  offset  size  orig fr  usr pgs  free pg
        303cf2a8  F-----  0      2500  2253    2253    2245
        path: /usr11/myname/sbspace1

        start pg  npages
Ud1  :    53      1126
Md   :   1179    194
Ud2  :   1373   1127

```

Output for the `onstat -g smb s` command

The `onstat -g smb s` command displays the storage attributes for all sbspaces in the system:

- sbspace name, flags, owner
- logging status
- average smart-large-object size

- first extent size, next extent size, and minimum extent size
- maximum I/O access time
- lock mode

For more information on the **onstat -g smb** command, see the *IBM Informix Performance Guide*.

onstat -g smx command: Print multiplexer group information

Use the **onstat -g smx** command to display information about the server multiplexer group for servers using SMX.

Syntax:

```
▶▶ onstat -g smx [ses]
```

Command	Explanation
onstat -g smx	Displays SMX connection statistics
onstat -g smx ses	Displays SMX session statistics

Example output

```
SMX connection statistics:
SMX control block: 0x47d5e028

Peer server name: lx1
SMX connection address: 0x47d60d10
Encryption status: Disabled
Total bytes sent: 27055
Total bytes received: 2006989
Total buffers sent: 782
Total buffers received: 7090
Total write calls: 782
Total read calls: 7090
Total retries for write call: 0
Data compression level: 1
Data sent: compressed 40760 bytes by 33%
Data received: compressed 12579324 bytes by 84%
```

Figure 21-111. **onstat -g smx** command output

Output description

SMX control block

SMX control block

Peer server name

Displays the name of the peer server

SMX connection address

Displays the address of the SMX connection

Encryption status

Displays whether encryption is enabled or disabled

- Total bytes sent*
Displays the total number of bytes sent
- Total bytes received*
Displays the total number of bytes received
- Total buffers sent*
Displays the total number of buffers sent
- Total buffers received*
Displays the total number of buffers received
- Total write calls*
Displays the total number of write calls
- Total read calls*
Displays the total number of read calls
- Total retries for write call*
Displays the total number of retries for write call
- Data compression level*
Displays the SMX compression level as set by the SMX_COMPRESS configuration parameter
- Data sent: compressed x bytes by y%*
Displays the uncompressed number of bytes and the compression ratio of the data sent
- Data received: compressed x bytes by y%*
Displays the uncompressed number of bytes and the compression ratio of the data received

Example Output

SMX session statistics:					
SMX control block: 0x17c69028					
Peer	SMX session	client	reads	writes	
name	address	type			
delhi_sec	19022050	smx Clone Send	6	183	

Figure 21-112. *onstat -g smx ses* Output

Output Description

- SMX control block*
SMX control block
- Peer name*
Displays the name of the peer server
- SMX session address*
SMX session address
- Client type*
Displays type of secondary server
- reads* Displays the total number of session reads
- writes* Displays the total number of session writes

onstat -g spi command: Print spin locks with long spins

Use the **onstat -g spi** command to display information about spin locks with long spins.

Syntax:

```
▶▶ onstat -g spi ▶▶
```

Many resources in the server are accessed by two or more threads. In some of these accesses (such as updating a shared value), the server must guarantee that only one thread is accessing the resource at a time. A *spin lock* is the mechanism used to provide this mutually exclusive access for some resources. With this type of lock, a thread that did not succeed in acquiring the lock on the first try (because another thread was holding it) repeatedly attempts to acquire the lock until it succeeds.

The overhead cost of a spin lock is small, and spin locks are normally used for resources that require mutual exclusion for short periods of time. However, if a spin lock becomes highly contended, the loop-and-retry mechanism can become expensive.

The **onstat -g spi** command is helpful for identifying performance bottlenecks that are caused by highly contended spin locks. This option lists spin locks with waits, those spin locks for which a thread was not successful in acquiring the lock on its first attempt and thus had to loop and re-attempt.

Example output

Spin locks with waits:			
Num Waits	Num Loops	Avg Loop/Wait	Name
114	117675	1032.24	lockfr3
87	256461	2947.83	fast mutex, lockhash[832]
1	11	11.00	fast mutex, 1:bhash[16668]
4	51831	12957.75	fast mutex, 1:lru-4
1	490	490.00	fast mutex, 1:bf[994850] 0xe00002 0x14eb32000

Figure 21-113. **onstat -g spi** command output

Output description

Num Waits (decimal)

Total number of times a thread waited for this spin lock.

Num Loops (decimal)

Total number of attempts before a thread successfully acquired the spin lock.

Avg Loop/Wait (floating point)

Average number of attempts needed to acquire the spin lock. Computed as Num Loops / Num Waits.

Name (string)

Uses the following codes to name the spin lock

lockfr The lock free list. The number after **lockfr** is the index into the lock free list array.

lockhash[]

The lock hash bucket. The field inside the brackets is the index into the lock hash bucket array.

:bhash []

The buffer hash bucket. The field before the colon is the buffer pool index; the field inside the brackets after **bhash** is the index into the buffer hash bucket array.

:lru-

The LRU latch. The field before the colon is the buffer pool index; the field after **lru-** identifies the buffer chain pairs that are being used.

:bf[]

The buffer latch. The field before the colon is the buffer pool index; the field inside the brackets after **bf** is the position of buffer in the buffer array. The next two fields are the partition number and the page header address in memory for the buffer in hex form.

onstat -g sql command: Print SQL-related session information

Use the **onstat -g sql** command to display SQL-related information about a session.

By default, only the DBSA can view **onstat -g sql** syssqltrace information. However, when the UNSECURE_ONSTAT configuration parameter is set to 1, all users can view this information.

Syntax:

```
▶▶ onstat -g sql sessionid ◀◀
```

You can specify one of the following invocations.

Invocation

Explanation

onstat -g sql

Displays a one line summary for each session

onstat -g sqlsessionid

Displays SQL information for a specific session

Note: Encrypted passwords and password hint parameters in encryption functions are not shown. The following figure displays an encrypted password in the Last parsed SQL statement field.

```
onstat -g sql 22

Sess  SQL           Current      Iso Lock      SQL  ISAM F.E.      Current
Id    Stmt type     Database    Lvl Mode     ERR  ERR  Vers Explain  Role
22    -             test        CR Not Wait   0    0    9.03 Off      hr
Last parsed SQL statement :
  select id, name, decrypt_char(ssn, 'XXXXXXXXXX') from emp
```

Figure 21-114. **onstat -g sql** command output

Output description

Sess id The session identifier

SQL Stmt type

The type of SQL statement

Current Database

Name of the current database of the session

ISO Lvl

Isolation level

DR Dirty Read

CR Committed Read

CS Cursor Stability

DRU Dirty Read, Retain Update Locks

CRU Committed Read, Retain Update Locks

CSU Cursor Stability, Retain Update Locks

LC Committed Read, Last Committed

LCU Committed Read Last Committed with Retain Update Locks

RR Repeatable Read

NL Database Without Transactions

Lock mode

Lock mode of the current session

SQL Error

SQL error number encountered by the current statement

ISAM Error

ISAM error number encountered by the current statement

F.E. Version

The version of the SQLI protocol used by the client program

Explain

SET EXPLAIN setting

Current Role

Role of the current user

onstat -g src command: Patterns in shared memory

Use the **onstat -g src** command to search for patterns in shared memory.

Syntax:

▶▶ onstat -g src pattern mask ◀◀

Example output

The following example shows output for the **onstat -g src pattern mask** command where *pattern* = 0x123 and *mask* = 0xffff.

```

Search Summary:
addr           contents
000000000ad17a50: 01090000 00000000 00000000 00000123  ....#
000000000ad7dec0: 00000001 014e3a0c 00000000 0ade0123  ....N:  ....#

```

Figure 21-115. **onstat -g src** command output

Output description

addr (hexadecimal)

Address in shared memory where search pattern is found

contents (hexadecimal)

Contents of memory at given address

onstat -g ssc command: Print SQL statement occurrences

Use the **onstat -g ssc** command to monitor the number of times that the database server reads the SQL statement in the cache.

By default, only the DBSA can view **onstat -g ssc** `syssqltrace` information. However, when the `UNSECURE_ONSTAT` configuration parameter is set to 1, all users can view this information.

Syntax:

```

▶▶ onstat -g ssc [all | pool]

```

The **all** option reports the *key-only* cache entries as well as the fully cached statements. If the value in the **hits** column is less than the `STMT_CACHE_HITS` value, that entry is a *key-only* cache entry. For more information, see memory utilization in the *IBM Informix Performance Guide*.

The **pool** option reports usage of all memory pools for the SQL statement cache. The output displays information on the name, class, address, and total size of the memory pools. For more information, see improving query performance in the *IBM Informix Performance Guide*.

Example output

```

Statement Cache Summary:
#lrus  currsz  maxsz  Poolsize #hits nolimit
4      117640 524288 139264  0      1
Statement Cache Entries:
lru hash ref_cnt hits flag heap_ptr      database      user
-----
0 262    0   7  -F aad8038      sscsi007      admin
INSERT INTO ssc1 ( t1_char , t1_short , t1_key , t1_float , t1_smallfloat
, t1_decimal , t1_serial ) VALUES ( ? , ? , ? , ? , ? , ? , ? )
0 127    0   9  -F b321438      sscsi007      admin
INSERT INTO ssc2 ( t2_char , t2_key , t2_short ) VALUES ( ? , ? , ? )
1 134    0  15  -F aae0c38      sscsi007      admin
SELECT t1_char , t1_short , t1_key , t1_float , t1_smallfloat ,
t1_decimal , t1_serial FROM ssc1 WHERE t1_key = ?
1 143    0   3  -F b322c38      sscsi007      admin
INSERT INTO ssc1 ( t1_char , t1_key , t1_short ) SELECT t2_char , t2_key
+ ? , t2_short FROM ssc2
2 93     0   7  -F aae9838      sscsi007      admin
DELETE FROM ssc1 WHERE t1_key = ?
2 276    0   7  -F aaefc38      sscsi007      admin
SELECT count ( * ) FROM ssc1
2 240    1   7  -F b332838      sscsi007      admin
SELECT COUNT ( * ) FROM ssc1 WHERE t1_char = ? AND t1_key = ? AND
t1_short = ?
3 31     0   7  -F aaec038      sscsi007      admin
SELECT count ( * ) FROM ssc1 WHERE t1_key = ?
3 45     0   1  -F b31e438      sscsi007      admin
DELETE FROM ssc1
3 116    0   0  -F b362038      sscsi007      admin
SELECT COUNT ( * ) FROM ssc1
Total number of entries: 10.

```

Figure 21-116. **onstat -g ssc** command output

Output description - Statement Cache Summary section

#lrus Number of least recently used queues (LRUS)

currsz
Current cache size

maxsz
Limit on total cache memory

Poolsize
Total pool size

#hits The number of hits before insertion. This number equals the value of the STMT_CACHE_HITS configuration parameter

nolimit The value of the STMT_CACHE_NOLIMIT configuration parameter

Output description - Statement Cache Entries section

The Statement Cache Entries section shows the entries that are fully inserted into the cache.

lru The index of lru queue to which the cache entry belongs

hash Hash values of cached entry

ref_count
Number of threads referencing the statement

hits Number of times a statement matches a statement in the cache. The match can be for a key-only or fully cached entry.

flag Cache entry flag -F indicates the statement is fully cached -D indicates the statement is dropped

heap_ptr
Address of memory heap for cache entry

onstat -g stk command: Print thread stack

Use the **onstat -g stk *tid*** command to display the stack of the thread specified by thread ID.

Syntax:

▶▶ onstat -g stk *tid* ◀◀

Example output

```
Stack for thread: 2 adminthd
base: 0x000000010aad5028
len: 33280
pc: 0x00000001002821e8
tos: 0x000000010aad621
state: running
vp: 2

0x1002821e8 oninit :: yield_processor + 0x260 sp=0x10aadce20(0x10ac834d0, 0x0, 0x1,
0x100000000, 0xc8a000, 0x100c8a000)
0x100274e38 oninit :: wake_periodic + 0xdc sp=0x10aadced0 delta_sp=176(0x41b0, 0xc7a024bc,
0x0, 0x41c4, 0x10aacf598, 0x90)
0x100274fcc oninit :: admin_thread + 0x108 sp=0x10aadcf80 delta_sp=176(0x0, 0x2328,
0xd26c00, 0x5, 0xc8a000, 0x156c)
0x1002484ec oninit :: startup + 0xd8 sp=0x10aadd050 delta_sp=208(0xa, 0x10aad47d0,
0x10aad47d0, 0x100db1988, 0xd1dc00, 0x1)
```

Figure 21-117. **onstat -g stk *tid*** command output

onstat -g stm command: Print SQL statement memory usage

Use the **onstat -g stm** command to display the memory that each prepared SQL statement uses.

By default, only the DBSA can view **onstat -g stm** syssqltrace information. However, when the UNSECURE_ONSTAT configuration parameter is set to 1, all users can view this information.

Syntax:

▶▶ onstat -g stm ◀◀

To display the memory for only one session, specify the session ID in the **onstat -g stm** command.

Example output

```
session 65 -----  
sdblock heapsz statement ('*' = Open cursor)  
aad8028 16544 SELECT COUNT ( * ) FROM ssc1 WHERE t1_char = ?  
AND t1_key = ? AND t1_short = ?
```

Figure 21-118. `onstat -g stm` command output

Output description

sdblock Address of the statement descriptor block

heapsz Size of the statement memory heap

statement

Query text

onstat -g stq command: Print queue information

Use the `onstat -g stq` command to display information about the queue.

Syntax:

```
▶▶ onstat -g stq session ▶▶
```

To view queue information for a particular session specify the *session* option. Omit the *session* option to view queue information for all sessions.

Example output

```
Stream Queue: (session 25 cnt 4) 0:db12400 1:db18400 2:dcf0400 3:dcf6400  
Full Queue: (cnt 2 waiters 0) 0:0 1:db12400  
Empty Queue: (cnt 0 waiters 0)
```

Figure 21-119. `onstat -g stq` command output

Output description

session Session id

cnt Number of stream queue buffers

waiters Number of threads waiting for the stream queue buffer

onstat -g sts command: Print stack usage for each thread

Use the `onstat -g sts` command to display information about the maximum and current stack use for each thread.

Syntax:

```
▶▶ onstat -g sts ▶▶
```

Example output

```
Stack usage:
```

TID	Total	Max bytes	%	Current bytes	%	Thread Name
2	32768	3124	9	3079	9	adminthd
3	32768	2870	8	2871	8	childthd
5	32768	14871	45	2871	8	Cosvr Avail Mgr
6	32768	2870	8	2871	8	dfm_svc
7	131072	3190	2	3191	2	xmf_svc
9	32768	3126	9	3127	9	xtm_svcc
10	32768	3580	10	3335	10	xtm_svcp
11	32768	3238	9	3239	9	cfgmgr_svc
12	32768	6484	19	2871	8	lio vp 0
14	32768	6484	19	2871	8	pio vp 0
16	32768	6484	19	2871	8	aio vp 0
18	131072	10391	7	2871	2	msc vp 0
20	32768	4964	15	2871	8	fifo vp 0
22	32768	4964	15	2871	8	fifo vp 1
24	32768	6028	18	2871	8	aio vp 1
26	32768	5444	16	2951	9	dfmxml_svc
27	32768	2886	8	2887	8	sch_svc
28	32768	7812	23	5015	15	rqm_svc
29	32768	7140	21	3079	9	sm_poll
30	32768	11828	36	6439	19	sm_listen
31	32768	2870	8	2871	8	sm_discon
32	32768	14487	44	4055	12	main_loop()
33	32768	4272	13	2903	8	flush_sub(0)
34	32768	2902	8	2903	8	flush_sub(1)
35	32768	2870	8	2871	8	btscanner 0
36	32768	3238	9	3239	9	aslogflush
37	32768	3055	9	2887	8	bum_local
38	32768	3238	9	3239	9	bum_rcv
39	32768	4902	14	4903	14	onmode_mon
42	32768	4964	15	2871	8	lio vp 1
44	32768	5136	15	2871	8	pio vp 1

Figure 21-120. `onstat -g sts` command output

`onstat -g sym` command: Print symbol table information for the `oninit` utility

Use the `onstat -g sym` command to display symbol table information for the `oninit` utility.

Syntax:

```
▶▶ onstat -g sym ◀◀
```

Example output

The following example shows the first few lines from the output:

```
Table for oninit has 23378 entries
Initial value for -base-: 0x0
0x3451e0 _start
0x345300 .ld_int
0x345348 .ld_llong
0x3453dc .ld_float
0x345428 .ld_double
0x3454c4 .st_int
0x3454fc .st_llong
0x34556c .st_float
0x3455c0 .st_double
0x34565c .st_float_foreff
0x345694 .st_double_foreff
0x345718 main
0x34c2ac get_cfgfile
0x34c2fc is_server_alias
```

Figure 21-121. **onstat -g sym** command output

Output description

The **onstat -g sym** command displays the relative in-memory address and name of symbols (functions and variables) in the **oninit** utility.

onstat -g sync command: Print ER synchronization status

Use the **onstat -g sync** command to display the synchronization status when Enterprise Replication is used.

The **onstat -g sync** command is used primarily as a debugging tool and most often by Technical Support.

Syntax:

```
▶▶ onstat -g sync ◀◀
```

Example output

Prim Repl	Sync Source	St.	Shadow Repl	Flag	Stat	Block Num	EndBlk Num
655361	20	0	1310729	2	0	592	600

Figure 21-122. **onstat -g sync** command output

Output description

Prim Repl

Replicate number of the replicate being synchronized

Sync Source

Source server of the sync

St

Sync replicate state

Shadow Repl

The shadow replicate used to perform the sync

- Flag* Internal flags:
- 0x02 = external sync
 - 0x04 = shutdown request has been issued
 - 0x08 = abort has occurred
 - 0x010 = a replicate stop has been requested
 - 0x020 = shadow or primary replicate has been deleted

Stat Resync job state

Block num
Last block applied on targets (on source always 0)

EndBlock Num
Last block in resync process. Marks the end of the sync scan on the target. A value of -2 indicates that the scan is still in progress, and the highest block number is not yet known.

Additional fields for forwarded rows:

ServID Server where forwarded row originated

fwdLog ID
Originator's log ID of the forwarded row

fwdLog POS
Originator's log position of the forwarded row

endLog ID
Operation switches back to normal at this point

endLog POS
Operation switches back to normal at this log position

complete flag
Set to 1 after normal processing resumes for the originating source.

onstat -g tpf command: Print thread profiles

Use the **onstat -g tpf** command to display thread profiles.

Syntax:

▶▶ onstat -g tpf *tid* ▶▶

Specify the *tid* thread ID to print the profile for a specific thread. Set *tid* to 0 to display the profiles for all of the threads.

Example output

```
onstat -g tpf 945

Thread profiles
tid lkreqs lkw dl to lgrs isrd iswr isrw isdl isct isrb lx bfr bfw lsus lsmx seq
945 1969 0 0 0 6181 1782 2069 13 0 0 0 0 16183 7348 743580 0 6
```

Figure 21-123. **onstat -g tpf** command output

Output description

<i>tid</i>	Thread ID
<i>lkreqs</i>	Lock requests
<i>lkw</i>	Lock waits
<i>dl</i>	Deadlocks
<i>to</i>	Remote deadlock timeout
<i>lgrs</i>	Log records
<i>isrd</i>	Number of reads
<i>iswr</i>	Number of writes
<i>isrw</i>	Number of rewrites
<i>isdl</i>	Number of deletes
<i>isct</i>	Number of commits
<i>isrb</i>	Number of rollbacks
<i>lx</i>	Long transactions
<i>bfr</i>	Buffer reads
<i>bfw</i>	Buffer writes
<i>lsus</i>	Log space currently used
<i>lsmx</i>	Max log space used
<i>seq</i>	Sequence scans

onstat -g ufr command: Print memory pool fragments

Use the **onstat -g ufr** command to display a list of the fragments that are currently in use in the specified memory pool.

This command requires an additional argument to specify either a pool name or session ID whose memory pool information is to be displayed. Each session is allocated a memory pool with the same name as the session ID. Use the **onstat -g mem** command to identify the pool name and the **onstat -g ses** command to identify the session ID.

Syntax:

```
▶▶ onstat -g ufr [pool name | sessionid] ▶▶
```

Memory pools are broken into fragments for various uses. With the **onstat -g ufr** command it is possible to see a list of these fragments showing their respective sizes in bytes and the type of information they contain. The information provided is generally used by Technical Support to assist in the analysis of a reported problem.

Example output for a specified pool name

```
Memory usage for pool name global:
size      memid
1736      overhead
23544     mcbmsg
72        messages
33112     osend
25432     rsam
88        shmbklist
5170664   net
```

Figure 21-124. `onstat -g ufr global` command output for a specified pool name

Example output for a specified session ID

The following example shows the output for session ID 6.

```
Memory usage for pool name 6:
size      memid
3256      overhead
144       scb
2968      ostcb
18896     sqscb
3312      opentable
72        sql
808       filetable
352       fragman
552       hashfiletab
1584      gentcb
12096     log
2960      sqtcb
2928      osend
720       keys
224       rdahead
16248     temprec
```

Figure 21-125. `onstat -g ufr` command output for a specified session ID

Output description

size (decimal)

Size, in bytes, of the pool fragment.

memid (string)

Name of the pool fragment.

onstat -g vpcache command: Print CPU VP memory block cache statistics

Use the `onstat -g vpcache` command to display information about CPU VP memory block cache statistics.

Syntax:

▶▶ onstat -g vpcache ▶▶

Example output

```
CPU VP memory block cache statistics - 4096 byte blocks

Number of 4096 byte memory blocks requested for each CPU VP:250

vpid   pid       Blocks held Hit percentage   Free cache
1      7889      193          77.4 %          21.9 %

Current VP total allocations from cache:      0
  size  cur blks  alloc  miss  free  drain
  1     30     13     4     43     0
  2     12     3      0     9     0
  3     42     7      0     21    0
  4     4      0      0     1     0
  5     0      0      0     0     0
  6     0      0      0     0     0
  7     0      0      0     0     0
  8     8      0      0     1     0
  9     63     0      0     7     0
 10     0      0      0     0     0
 11     0      0      0     0     0
 12     0      0      0     0     0
 13     0      0      0     0     0
 14     0      0      0     0     0
 15     0      0      0     0     0
 16     0      0      0     0     0
 17    34     1      3     3     0
 18     0      0      0     0     0
 19     0      0      0     0     0
 20     0      0      0     0     0
 21     0      0      0     0     0
 22     0      0      0     0     0
 23     0      0      0     0     0
 24     0      0      0     0     0
 25     0      0      0     0     0
 26     0      0      0     0     0
 27     0      0      0     0     0
 28     0      0      0     0     0
 29     0      0      0     0     0
 30     0      0      0     0     0
 31     0      0      0     0     0
 32     0      0      0     0     0
```

Figure 21-126. `onstat -g vpcache` command output

Output description

size Is the size of the memory blocks in 4096 byte blocks

cur blks

Is the current number of 4096 blocks, a multiple of *size*

alloc Is the number of times a requestor received a block of this size

miss Is the number of times a block was requested but none were available

free Is the number of times a memory block was placed into the cache

drain Is the number of times an aged block was forced out to make room for another block

onstat -g wai command: Print wait queue thread list

Use the **onstat -g wai** command to display a list of the threads in the system that are currently in the wait queue and not currently executing. The output is sorted by thread ID.

Syntax:

▶▶ onstat -g wai ◀◀

Example output

Waiting threads:						
tid	tcb	rstcb	prty	status	vp-	name
2	46b1ea40	0	1	IO Idle	5lio	lio vp 0
3	46b3dc58	0	1	IO Idle	6pio	pio vp 0
4	46b5dc58	0	1	IO Idle	7aio	aio vp 0
5	46b7cc58	0	1	IO Idle	8msc	msc vp 0
6	46b1ed10	460f5028	1	sleeping secs: 1	3cpu	main_loop()
9	46d0d6e0	0	1	sleeping forever	1cpu	soctcplst
10	46d70b48	0	1	sleeping forever	3cpu	sm_listen
11	46e5d9a0	0	1	sleeping secs: 1	3cpu	sm_discon
12	46e5dc70	460f5820	1	sleeping secs: 1	3cpu	flush_sub(0)
13	46e8a5a8	460f6018	1	sleeping secs: 1	3cpu	aslogflush
14	46fe8148	460f6810	1	sleeping secs: 41	3cpu	btscanner_0
15	46fe84a8	0	1	IO Idle	10aio	aio vp 1
16	46fe8778	460f7008	1	sleeping secs: 1	1cpu	onmode_mon
36	47531960	460f7ff8	1	sleeping secs: 253	3cpu	dbScheduler
37	47531c30	460f87f0	1	sleeping forever	4cpu	dbWorker1
38	47491028	460f7800	1	sleeping forever	4cpu	dbWorker2

Figure 21-127. **onstat -g wai** command output

Output description

tid (decimal)

Thread ID

tcb (hex)

In-memory address of the thread control block

rstcb (hex)

In-memory address of the RSAM thread control block

prty (decimal)

Thread priority. Higher numbers represent higher priorities

status (string)

Current status of the thread

vp- (decimal and string)

Virtual processor integer ID of the VP on which the thread last ran, concatenated with the name of the VP upon which the thread runs

name (string)

Name of the thread

onstat -g wmx command: Print all mutexes with waiters

Use the **onstat -g wmx** command to display all of the mutexes with waiters.

Syntax:

```
▶▶ onstat -g wmx ◀◀
```

Example output

```
Mutexes with waiters:
mid      addr          name          holder  lkcnt  waiter  waittime
```

Figure 21-128. `onstat -g wmx` command output

onstat -g wst command: Print wait statistics for threads

Use the `onstat -g wst` command to display the wait statistics for the threads within the system.

The WSTATS configuration parameter must be set to 1 to enable wait statistics collection. For more information, see “WSTATS configuration parameter” on page 1-170.

Syntax:

```
▶▶ onstat -g wst ◀◀
```

Example output

Figure 21-129. `onstat -g wst` command output

```
Version 11.70.F -- On-Line -- Up 18:52:59 -- 78856 Kbytes
name  tid  state          n      avg(us)  max(us)
msc vp 0 5  ready         6         9        17
msc vp 0 5  run           6       1107     2215
msc vp 0 5  IO Idle       5     2985.9s  1496.1s

main_loo 7  IO Wait       55         6496   16725
main_loo 7  yield time   44929         1.2s   343.1s
main_loo 7  ready       44998     206085   343.1s
main_loo 7  run        44985         5         436

...

sqlxec 63  IO Wait       2         1118    2165
sqlxec 63  other cond    6     34237  204142
sqlxec 63  ready        9         7        16
sqlxec 63  run         7         1.1s    7.7s
```

Output description

name (string)

Thread name

tid (decimal)

Thread ID

state (string)

State the thread waited in for this line of output. A single thread can have multiple lines of output if it has waited in more than one different state. Values that can appear in the state include:

chkpt cond: The thread waited for a checkpoint condition.

cp mutex: The thread waited for checkpoint mutex to become available.

deadlock mutex: The thread waited for a deadlock mutex to become available.

empty Q: The thread waited for an empty buffer on a queue.

fork: The thread waited for a child thread to run.

full Q: The thread waited for a full buffer on a queue.

I0 Idle: The I/O thread was idle.

I0 Wait: The thread yielded while waiting for I/O completion.

join wait: The thread waited for another thread to exit.

lock mutex: The thread waited for lock mutex to become available.

lockfree mutex: The thread waited for a lock-free mutex to become available.

logflush: Logical log flushing occurred.

log mutex: The thread waited for logical log mutex to become available.

logcopy cond: The thread waited for logical log copy condition.

logio cond: The thread waited for a logical log condition.

lrus mutex: The thread waited for a buffer LRU mutex to become available.

misc: The thread waited for a miscellaneous reason.

other cond: The thread waited for an internal condition.

other mutex: The thread waited for an internal system mutex to become available.

other yield: The thread yielded for an internal reason.

OS read: The thread waited for an operating system read call to complete.

OS write: The thread waited for an operating system write call to complete.

ready: The thread was ready to run.

run: The thread ran.

sort io: The thread waited for sort I/O completion.

vp mem sync: The thread waited for synchronization of virtual processor memory.

yield bufwait: The thread yielded while waiting for a buffer to become available.

yield 0: The thread yielded with an immediate timeout.

yield time: The thread yielded with a timeout.

yield forever: The thread yielded and will stay that way until it wakes up.

n (decimal)

Number of times the thread waited in this state

avg(us) (floating point)

Average user time the thread spent waiting in this state per wait occurrence. Time is in microseconds; an *s* after the value indicates user time in seconds.

max(us) (floating point)

Maximum user time the thread spent waiting in this state for a single wait occurrence. Time is in microseconds; an *s* after the value indicates user time in seconds.

Related reference:

“**onstat -g ath** command: Print information about all threads” on page 21-54

onstat -G command: Print TP/XA transaction information

Use the **onstat -G** command to display information about global transactions generated through the TP/XA library.

Syntax:

▶▶ onstat -G ◀◀

Example output

```
Global Transaction Identifiers
address  flags  isol  timeout  fID      gtl  bql  data
ae35e34  -LR-G  COMMIT  0        4478019  16  48  438709F23076254C80F33A62B
AF4CF763C1BCFFAD7AE0243AA5CE243FA5381C903AA9F52A1546044992C5A7BC03582E77999EFBA7
25D3D40BDAF37404D9DAFF1
ae3623c  AL--G  COMMIT  0        4478019  16  48  438709F23076254C80F33A62B
AF4CF763C1BCFFAD7AE0243AA5CE243FA5381C903AA9F52A1546044992C5A7BC03582E77999EFBA7
25D3D40BDAF37404D9DA000
2 active, 128 total
```

Figure 21-130. **onstat -G** command output

For a tightly coupled transaction, all branches will share the same transaction address shown in the address column.

Output description**address**

Transaction address

flags

The flag codes for position 1 (current transaction state):

- A** User thread attached to the transaction
- S** TP/XA suspended transaction
- C** TP/XA waiting for rollback

The flag codes for position 2 (transaction mode):

- T** Tightly-coupled mode (MTS)
- L** Loosely-coupled mode (default mode)

The flag codes for position 3 (transaction stage):

- B** Begin work
- P** Distributed query prepared for commit
- X** TP/XA prepared for commit
- C** Committing or committed
- R** Rolling back or rolled back
- H** Heuristically rolling back or rolled back

The flag code for position 4:

- X** XA DataSource global transaction

The flag codes for position 5 (type of transaction):

- G** Global transaction
- C** Distributed query coordinator
- S** Distributed query subordinate
- B** Both distributed query coordinator and subordinate
- M** Redirected global transaction

isol Transaction isolation level

timeout
Transaction lock timeout

fID Format ID

gtl Global transaction ID length

bql Branch qualifier length

data Transaction-specific data

onstat -h command: Print buffer header hash chain information

Use the **onstat -h** command to display information about the buffer header hash chains (sometimes called "hash buckets") that are used to access pages in each buffer pool.

Syntax:

▶▶ onstat -h ◀◀

Example output

The output is displayed in the form of a numeric histogram of chain lengths, with summary information for each buffer pool. All numeric values in the output are decimal. Shorter hash chains enable requested buffers to be located more quickly by the server, because on average it will need to check fewer buffer headers on a target chain to find the target buffer.

The page size of the buffer pool in bytes is shown as a header to the output for each buffer pool. The histogram and summary information are then presented for that buffer pool.

```

Buffer pool page size: 2048

buffer hash chain length histogram
# of chains      of len
    3423          0
    4546          1
    223           2
    8192 total chains
    4992 hashed buffs
    5000 total buffs

Buffer pool page size: 4096

buffer hash chain length histogram
# of chains      of len
    707           0
    315           1
    2             2
    1024 total chains
    319 hashed buffs
    1000 total buffs

```

Figure 21-131. **onstat -h** command output

Output description

Histogram Information on Hash Chains

The histogram information has a row for each buffer hash chain length that presently exists in the system. Each row has two columns:

of chains

Number of hash chains of the given length

of len Length of these chains

Summary Information Per Buffer Pool

total chains

Number of hash chains that exist for this buffer pool

hashed buffs

Number of buffer headers currently hashed into the hash chains for this buffer pool

total buffs

Total number of buffers in this buffer pool

onstat -i command: Initiate interactive mode

Use the **onstat -i** command to put the **onstat** utility in the interactive mode.

Syntax:



In interactive mode, you can enter multiple **onstat** options per session, but only one at a time. An **onstat** prompt appears and allows you to enter an option.

Important: In interactive mode, do not precede the option with a dash.

Additional options

Two additional options, **onstat r seconds** and **onstat rz seconds**, are available in interactive mode. The **onstat r seconds** option is similar to the current **onstat -r seconds** option, which repeatedly generates a display. If an administrator executes **onstat r seconds** at the interactive-mode prompt, the prompt changes to reflect the specified interval in seconds and reappears, waiting for the next command. In the following example, the display generated by the next command repeats every three seconds:

```
onstat> r 3
onstat[3]>
```

The **onstat rz seconds** option enables you to repeat the next command as specified and set all profile counters to 0 between each execution.

Terminating interactive mode or repeating sequence

To terminate the interactive mode, press CTRL-d.

To terminate a repeating sequence, press CTRL-c.

onstat -j command: Provide onpload status information

Use the **onstat -j** command to provide information about the status of an **onpload** job.

The **onstat -j** command provides an interactive mode that is analogous to the **onstat -i** command.

Syntax:

```
▶▶ onstat -j ◀◀
```

When the **onpload** starts, it writes a series of messages to **stdout** or to a log file. The following lines show a typical **onpload** log file:

```
Mon Jul 23 16:11:30 2010
```

```
SHMBASE      0x4400000
CLIENTNUM    0x49010000
Session ID 1
```

```
Load Database -> cnv001
Load Table    -> cnv001a
Load File     -> testrec.dat
Record Mapping -> cnv001a
```

```
Database Load Completed -- Processed 50 Records
Records Inserted-> 50
Detected Errors--> 0
Engine Rejected--> 0
```

```
Mon Jul 23 16:11:37 2010
```

Output description

The two lines that start with SHMBASE and CLIENTNUM provide the information that you need to locate shared memory for an instance of **onpload**. The **oninit** process has similar values stored in the **\$ONCONFIG** file. When you use the

onstat utility to gather information about the **oninit** process, the **onstat** utility uses information from **\$INFORMIXDIR/etc/\$ONCONFIG** file to locate shared memory. When you use **onstat** to gather information about **onpload**, you must give the **onstat** utility the name of a file that contains SHMBASE and CLIENTNUM information.

Typically the file that contains the SHMBASE and CLIENTNUM information is the log file. For example, if the **onpload** log file is **/tmp/cnv001a.log**, you can enter the following command:

```
onstat -j /tmp/cnv001a.log
```

The previous command causes the **onstat** utility to attach to **onpload** shared memory and to enter interactive mode. You can then enter **?** or any other pseudo request to see a usage message displayed. An example follows:

```
onstat> ?
Interactive Mode: One command per line, and - are optional.
  -rz      repeat option every n seconds (default: 5) and
          zero profile counts
MT COMMANDS:
  all      Print all MT information
  ath      Print all threads
  wai      Print waiting threads
  act      Print active threads
  rea      Print ready threads
  sle      Print all sleeping threads
  spi      print spin locks with long spins
  sch      print VP scheduler statistics
  lmx      Print all locked mutexes
  wmx      Print all mutexes with waiters
  con      Print conditions with waiters
  stk <tid> Dump the stack of a specified thread
  glo      Print MT global information
  mem <pool name|session id> print pool statistics.
  seg      Print memory segment statistics.
  rbm      print block map for resident segment
  nbm      print block map for non-resident segments
  afr <pool name|session id> Print allocated pool fragments.
  ffr <pool name|session id> Print free pool fragments.
  ufr <pool name|session id> Print pool usage breakdown
  iov      Print disk IO statistics by vp
  iof      Print disk IO statistics by chunk/file
  ioq      Print disk IO statistics by queue
  iog      Print AIO global information
  iob      Print big buffer usage by IO VP
  sts      Print max and current stack sizes
  qst      print queue statistics
  wst      print thread wait statistics
  jal      Print all Pload information
  jct      Print Pload control table
  jpa      Print Pload program arguments
  jta      Print Pload thread array
  jmq      Print Pload message queues, jms for summary only
onstat>
```

Most of the options are the same as those that you use to gather information about Informix, with the following exceptions:

```
jal      Print all Pload information
jct      Print Pload control table
jpa      Print Pload program arguments
jta      Print Pload thread array
jmq      Print Pload message queues, jms for summary only
```

These options apply only to **onpload**. You can use the **onstat -j** command to check the status of a thread, locate the VP and its PID, and then attach a debugger to a particular thread. The options for the **onstat** utility that do not apply to **onpload** are not available (for example, **onstat -g ses**).

onstat -k command: Print active lock information

Use the **onstat -k** command to print information about active locks, including the address of the lock in the lock table.

Syntax:

```
▶▶ onstat -k ◀◀
```

Example output

Note: The maximum number of locks available is specified as LOCKS in the ONCONFIG file.

```
Locks
address  wtlist  owner    lklist  type    tblsnum rowid    key#/bsiz
a095f78  0        a4d9e68  0        HDR+S   100002  203     0
1 active, 2000 total, 2048 hash buckets, 0 lock table overflows
```

Figure 21-132. **onstat -k** command output

Output description

address Is the address of the lock in the lock table

If a user thread is waiting for this lock, the address of the lock appears in the **wait** field of the **onstat -u** (users) output.

wtlist Is the first entry in the list of user threads that is waiting for the lock, if there is one

owner Is the shared-memory address of the thread that is holding the lock

This address corresponds to the address in the **address** field of **onstat -u** (users) output. When the *owner* value is displayed in parenthesis, it represents the shared memory address of a transaction structure. This scenario is possible only when a lock is allocated for a global transaction. This address corresponds to the address field of the output for **onstat -G**.

lklist Is the next lock in a linked list of locks held by the owner just listed

type Uses the following codes to indicate the type of lock:

HDR	Header
B	Bytes
S	Shared
X	Exclusive
I	Intent
U	Update
IX	Intent-exclusive

IS Intent-shared
SIX Shared, intent-exclusive

tblsnum

Is the tblspace number of the locked resource. If the number is less than 10000, it indicates Enterprise Replication pseudo locks.

rowid

Is the row identification number

The rowid provides the following lock information:

- If the rowid equals zero, the lock is a table lock.
- If the rowid ends in two zeros, the lock is a page lock.
- If the rowid is six digits or fewer and does not end in zero, the lock is probably a row lock.
- If the rowid is more than six digits, the lock is probably an index key-value lock.

key#/bsiz

Is the index key number, or the number of bytes locked for a VARCHAR lock

If this field contains 'K-' followed by a value, it is a key lock. The value identifies which index is being locked. For example, K-1 indicates a lock on the first index defined for the table.

onstat -l command: Print physical and logical log information

Use the **onstat -l** command to display information about the physical logs, logical logs, and temporary logical logs.

Syntax:

▶▶ onstat -l ◀◀

Example Output

```

Physical Logging
Buffer bufused  bufsize  numpages  numwrits  pages/io
P-1  0          16         716       55        13.02
      phybegin      physize  phypos    phyused   %used
      1:263         500     270      0         0.00

Logical Logging
Buffer bufused  bufsize  numrecs  numpages  numwrits  recs/pages  pages/io
L-3  0          16       42169    2872     1043      14.7      2.8
      Subsystem    numrecs  Log Space used
      OLDRSAM     42169   4436496

address  number  flags    uniqid   begin          size    used    %used
a517f70  1       U-B----  1        1:763          500    500    100.00
a517fb0  2       U-B----  2        1:1263         500    500    100.00
a40daf0  3       U-B----  3        1:1763         500    500    100.00
a40db30  4       U-B----  4        1:2263         500    500    100.00
a40db70  5       U-B----  5        1:2763         500    500    100.00
a40dbb0  6       U---C-L  6        1:3263         500    372    74.40
a40dbf0  7       A-----  0        1:3763         500    0      0.00
a40dc30  8       A-----  0        1:4263         500    0      0.00
8 active, 8 total

```

Figure 21-133. **onstat -l** command output

Output description for the physical log files

The first section of the display describes the physical-log configuration:

buffer Is the number of the physical-log buffer

bufused

Is the number of pages of the physical-log buffer that are used

bufsize Is the size of each physical-log buffer in pages

numpages

Is the number of pages written to the physical log

numwrits

Is the number of writes to disk

pages/io

Is calculated as $numpages/numwrits$

This value indicates how effectively physical-log writes are being buffered.

phybegin

Is the physical page number of the beginning of the log

physize Is the size of the physical log in pages

phypos Is the current position in the log where the next log-record write is to occur

phyused

Is the number of pages used in the log

%used Is the percent of pages used

The second section of the **onstat -l** command output describes the logical-log configuration:

buffer Is the number of the logical-log buffer

bufused Is the number of pages used in the logical-log buffer

bufsize Is the size of each logical-log buffer in pages

numrecs Is the number of records written

numpages Is the number of pages written

numwrits Is the number of writes to the logical log

recs/pages Is calculated as $\text{numrecs}/\text{numpages}$

You cannot affect this value. Different types of operations generate different types (and sizes) of records.

pages/io is calculated as $\text{numpages}/\text{numwrits}$

You can affect this value by changing the size of the logical-log buffer (specified as LOGBUFF in the ONCONFIG file) or by changing the logging mode of the database (from buffered to unbuffered, or vice versa).

The following fields are repeated for each logical-log file:

address Is the address of the log-file descriptor

number

Is logid number for the logical-log file

The logid numbers might be out of sequence because either the database server or administrator can insert a log file in-line.

flags Provides the status of each log as follows:

A Newly added (and ready to use)

B Backed up

C Current logical-log file

D Marked for deletion

To drop the log file and free its space for reuse, you must perform a level-0 backup of all storage spaces

F Free, available for use

L The most recent checkpoint record

U Used

uniqid Is the unique ID number of the log

begin Is the beginning page of the log file

size Is the size of the log in pages

used Is the number of pages used

%used Is the percent of pages used

active Is the number of active logical logs

total Is the total number of logical logs

Output description for temporary logical log files

The database server uses *temporary logical logs* during a warm restore because the permanent logs are not available then. The following fields are repeated for each temporary logical-log file:

address Is the address of the log-file descriptor

number Is logid number for the logical-log file

flags Provides the status of each log as follows:

- B** Backed up
- C** Current logical-log file
- F** Free, available for use
- U** Used

uniqid Is the unique ID number of the log

begin Is the beginning page of the log file

size Is the size of the log in pages

used Is the number of pages used

%used Is the percent of pages used

active Is the number of active temporary logical logs

Related reference:

“LOGBUFF configuration parameter” on page 1-87

“PHYSBUFF Configuration Parameter” on page 1-113

onstat -L command: Print the number of free locks

Use the **onstat -L** command to print the number of free locks on a lock-free list.

Syntax:

▶▶ onstat -L ◀◀

Example output - TEST WITH TABS VERSION 1

```
Distribution of available locks on the lock free lists
num list head  available locks  LOCKNAME  LOCKTYPE  LISTTYPE  LISTVALUE
0  10a143b70  19996      NAME1   TYPE1    LIST1    VALUE1
1  101010101  200       NAME2   TYPE2    LIST2    VALUE2
3  020202020  300       NAME3   TYPE3    LIST3    VALUE3
```

Figure 21-134. onstat -L output

Example output - TEST WITH TABS VERSION 2 (2 TABS BETWEEN)

```

Distribution of available locks on the lock free lists

num list head  available locks  LOCKNAME  LOCKTYPE  LISTTYPE  LISTVALUE
0  10a143b70  19996  NAME1  TYPE1  LIST1  VALUE1
1  101010101  200  NAME2  TYPE2  LIST2  VALUE2
3  020202020  300  NAME3  TYPE3  LIST3  VALUE3

```

Figure 21-135. **onstat -L** output

Example output - TEST WITH SPACES - VERSION 2

```

num  list head  available locks  LOCKNAME  LOCKTYPE  LISTTYPE  LISTVALUE
0  10a143b70  19996  NAME1  TYPE1  LIST1  VALUE1
1  101010101  200  NAME2  TYPE2  LIST2  VALUE2
3  020202020  300  NAME3  TYPE3  LIST3  VALUE3

```

Figure 21-136. **onstat -L** output

Example output - TEST WITH SPACES - VERSION 2

```

num  list head  available locks  LOCKNAME  LOCKTYPE  LISTTYPE  LISTVALUE
0  10a143b70  19996  NAME1  TYPE1  LIST1  VALUE1
1  101010101  200  NAME2  TYPE2  LIST2  VALUE2
3  020202020  300  NAME3  TYPE3  LIST3  VALUE3

```

Figure 21-137. **onstat -L** output

Output description

num The list number

list head

The starting address of the list

available locks

The number of locks on this list

onstat -m command: Print recent system message log information

Use the **onstat -m** command to display the 20 most recent lines of the system message log.

You can use the **onstat -m** command option with the database server in any mode, including offline.

Syntax:

▶▶ onstat -m ◀◀

Example output

Output from this command lists the full pathname of the message log file and the 20 file entries. A date-and-time header separates the entries for each day. A time stamp prefaces single entries within each day. The name of the message log is specified as MSGPATH in the ONCONFIG file.

```

Message Log File: /work/11.50/dbspaces/star3.log
11:26:33 Checkpoint Completed: duration was 0 seconds.
11:26:33 Checkpoint loguniqu 1, logpos 0x23c408, timestamp: 0x2cc2 Interval: 9

```

Figure 21-138. **onstat -m** command output

onstat -o command: Output shared memory contents to a file

Use the **onstat -o** command to write the contents of shared memory to a specified file for later analysis. If you do not specify an output file, a file named **onstat.out** is created in the current directory.

Syntax:

```

▶▶ onstat -o [nobuffs] [full] outfile

```

Use the **nobuffs** option to exclude the buffer pool in the resident segment of shared memory from the output file. This results in a smaller output file.

Use the **full** option to create an output file that is the same size as the shared memory segments for the IBM Informix instance. You must have enough room in the file system to handle the output.

If you do not specify either the **nobuffs** or the **full** option, the output is controlled by the database server DUMPSHMEM configuration parameter setting:

- If DUMPSHMEM is set to 0 or to 1, **onstat -o** command writes a full shared-memory dump file.
- If DUMPSHMEM is set to 2, **onstat -o** command writes a **nobuffs** shared-memory dump file that excludes the buffer pool in the resident segment.

By running additional **onstat** commands against the file, you can gather information from a previously saved shared memory dump. The *outfile* that you create with the **onstat -o** command is the *infile* that you can use as a source file to run the additional **onstat** commands. For more information, see “Running **onstat** Commands on a Shared Memory Dump File” on page 21-24.

onstat -O command: Print optical subsystem information

Use the **onstat -O** command to display information about the Optical Subsystem memory cache and the staging area blob space.

Syntax:

```

▶▶ onstat -O

```

Example output

The totals shown in the display accumulate from session to session. The database server resets the totals to 0 only when you run the **onstat -z** command.

Optical StageBlob Cache							
System Cache Totals:				System Blob Totals:			
Size	Alloc.	Avail.	Number	Kbytes	Number	Kbytes	
500	500	0	1	20	3	1500	
User Cache Totals:				User Blob Totals:			
SID	User	Size	Number	Kbytes	Number	Kbytes	
94	doug	250	1	20	1	300	
95	beth	500	0	0	2	1200	

Figure 21-139. **onstat -O** command output

Output description

The first section of the display provides the following information on system-cache totals:

size Is the size that the OPCACHEMAX configuration parameter specifies

alloc Is the number of 1-kilobyte allocations to the cache

avail Describes how much of **alloc** (in kilobytes) is not used

number

Is the number of simple large objects that the database server successfully put in the cache without overflowing

kbytes Is the number of kilobytes of TEXT or BYTE data that the database server put in the cache without overflowing

number

Is the number of simple large objects that the database server wrote to the staging-area blob space

kbytes Is the number of kilobytes of TEXT or BYTE data that the database server wrote to the staging-area blob space

Although the **size** output indicates the amount of memory that is specified in the configuration parameter OPCACHEMAX, the database server does not allocate memory to OPCACHEMAX until necessary. Therefore, the **alloc** output reflects only the number of 1-kilobyte allocations of the largest simple large object that has been processed. When the values in the **alloc** and **avail** output are equal to each other, the cache is empty.

The second section of the display describes the following user-cache totals information:

SID Is the session ID for the user

user Is the user ID of the client

size Is the size specified in the **INFORMIXOPCACHE** environment variable, if it is set

If you do not set the **INFORMIXOPCACHE** environment variable, the database server uses the size that you specify in the configuration parameter OPCACHEMAX.

number

Is the number of simple large objects that the database server put into cache without overflowing

kbytes Is the number of kilobytes of TEXT or BYTE data that the database server put in the cache without overflowing

number

Is the number of simple large objects that the database server wrote to the staging-area blob space

kbytes Is the number of kilobytes of TEXT or BYTE data that the database server wrote to the staging-area blob space

The last line of the display lists the total number of sessions that are using the cache.

onstat -p command: Print profile counts

Use the **onstat -p** command to display information about profile counts either since you started the database server or since you ran the **onstat -z** command.

Syntax:

▶▶ onstat -p ◀◀

Example output

Profile								
dskreads	pagreads	bufreads	%cached	dskwrits	pagwrits	bufwrits	%cached	
939	943	143905	99.35	3925	10816	46919	91.63	
isamtot	open	start	read	write	rewrite	delete	commit	rollbk
100055	15851	16112	24632	13343	1342	1392	905	0
gp_read	gp_write	gp_rewrt	gp_del	gp_alloc	gp_free	gp_curs		
0	0	0	0	0	0	0		
ovlock	ovuserthread	ovbuff	usercpu	syscpu	numckpts	flushes		
0	0	0	12.00	2.69	9	101		
bufwaits	lokwaits	lockreqs	deadlks	dltouts	ckpwaits	compress	seqscans	
8	0	26894	0	0	1	1247	478	
ixda-RA	idx-RA	da-RA	RA-pgsused	lchwaits				
5	0	10	15	23				

Figure 21-140. **onstat -p** command output

Output description

The first portion of the output describes reads and writes.

Reads and writes are tabulated in three categories: from disk, from buffers, and number of pages (read or written).

The first **%cached** field is a measure of the number of reads from buffers compared to reads from disk. The second **%cached** field is a measure of the number of writes to buffers compared to writes to disk.

The database server buffers the information and writes the information to the disk in pages. For this reason, the number of disk writes displayed as `dskwrits` is usually less than the number of writes that an individual user runs:

dskreads

The number of actual reads from disk

pagreads

The number of pages read

bufreads

Is the number of reads from shared memory

%cached

The percent of reads cached in the buffer pool.

If `bufreads` exceeds the maximum integer (or long) value, its internal representation becomes a negative number, but the value appears as 0.0.

dskwrits

The actual number of physical writes to disk

This number includes the writes for the physical and logical logs reported in `onstat -l`.

pagwrits

The number of pages written

bufwrits

The number of writes to shared memory

%cached

The percent of writes cached in the buffer pool.

The next portion of the `-p` display tabulates the number of times different ISAM calls were executed. The calls occur at the lowest level of operation and do not necessarily correspond one-to-one with SQL statement execution. A single query might generate multiple ISAM calls. These statistics are gathered across the database server and cannot be used to monitor activity on a single database unless only one database is active or only one database exists:

isamtot The total number of calls

open Increments when a `tblspace` is opened

start Increments the pointer within an index

read Increments when the read function is called

write Increments with each write call

rewrite Increments when an update occurs

delete Increments when a row is deleted

commit Increments each time that an `iscommit()` call is made

No one-to-one correspondence exists between this value and the number of explicit `COMMIT WORK` statements that are executed.

rollbk Increments when a transaction is rolled back

The next portion of the `onstat -p` command output displays information about generic pages. The Generic Page Manager provides an API for Informix to manage nonstandard pages in the database server buffer pool. The following table describes the Generic Page Manager fields in the `onstat -p` command output.

gp_read The number of generic page reads

gp_write The number of generic page writes

gp_rewrt The number of generic page updates

gp_del The number of generic page deletes

gp_alloc The number of generic page allocations

gp_free The number of generic pages freed and returned to tblspaces

gp_curs The number of cursors used against generic pages

The next portion of the **onstat -p** command output displays the number of times that a resource was requested when none was available:

ovlock The number of times that the database server attempted to allocate locks more than 15 times

For more information, see “LOCKS” on page 1-56.

ovuserthread The number of times that a user attempted to exceed the maximum number of user threads

ovbuff The number of times that the database server could not find a free shared-memory buffer

When no buffers are free, the database server writes a dirty buffer to disk and then tries to find a free buffer.

usercpu Is the total user CPU time that all user threads use, expressed in seconds
This entry is updated every 15 seconds.

syscpu The total system CPU time that all user threads use, expressed in seconds
This entry is updated every 15 seconds.

numckpts The number of checkpoints since the boot time

flushes The number of times that the buffer pool has been flushed to the disk

The next portion of the **onstat -p** command output contains miscellaneous information, as follows:

bufwaits Increments each time that a user thread must wait for a buffer

lokwaits Increments each time that a user thread must wait for a lock

lockreqs Increments each time that a lock is requested

deadlks Increments each time that a potential deadlock is detected and prevented

dltouts Increments each time that the distributed deadlock time-out value is exceeded while a user thread is waiting for a lock

ckpwaits

Is the number of checkpoint waits

compress

Increments each time that a data page is compressed

seqscans

Increments for each sequential scan

The last portion of the **onstat -p** command output contains the following information:

ixda-RA

The count of read-aheads that go from index leaves to data pages

idx-RA The count of read-aheads that traverse index leaves

da-RA The count of data-path-only scans

RA-pgsused

Indicates the number of pages used that the database server read ahead

lchwaits

Stores the number of times that a thread was required to wait for a shared-memory latch

A large number of latch waits typically results from a high volume of processing activity in which the database server is logging most of the transactions.

onstat -P command: Print partition information

Use the **onstat -P** command to display the partition number and the pages in the buffer pool for all of the partitions.

Syntax:

►► onstat -P ◀◀

For information about running **onstat -P** on a dump file created without the buffer pool, see “Running **onstat** Commands on a Shared Memory Dump File” on page 21-24.

Example output

```

Buffer pool page size: 2048
partnum total    btree    data    other    dirty
0         36      1         8       27       0
1048577  2         0         0       2        0
1048578  4         1         1       2        0
1048579  23        10        12      1        0
1048580  68        31        36      1        0
4194309  3         0         1       2        0

Totals: 3000    786    1779    435    0
Percentages:
Data 59.30
Btree 26.20
Other 14.50

Buffer pool page size: 8192
partnum total    btree    data    other    dirty
0         999      0         0       999     0
5242881  1         0         0       1       0

Totals: 1000    0       0       1000   0
Percentages:
Data 0.00
Btree 0.00
Other 100.00

```

Figure 21-141. **onstat -P** command output

Output description

Buffer pool page size

The size, in bytes, of the buffer pool pages.

partnum

The partition number.

total The total number of partitions.

btree The number of B-tree pages in the partition.

data The number of data pages in the partition.

other The number of other pages in the partition.

dirty The number of dirty pages in the partition.

onstat -r command: Repeatedly print selected statistics

Use the **onstat -r** command to repeatedly print the statistics for other options specified in the command at specified intervals.

Syntax:

```

▶▶ onstat -r [seconds] [other_options]

```

Use the **onstat -r seconds other_options** command to specify the seconds to repeat the other option.

Use **onstat -r *other_options*** command to have the option repeat every five seconds, which allows the other options to be concatenated with the **-r** option, as in this example: `onstat -rFh`.

The **onstat -r** command can be used in both command mode and interactive mode, and can be useful for repeating command output to monitor system resource utilization.

Example output running the `onstat -r` command every five seconds

```
onstat -r
IBM Informix Dynamic Server Version 11.70.F      -- On-Line -- Up 20:05:25 -- 1067288 Kbytes
IBM Informix Dynamic Server Version 11.70.F      -- On-Line -- Up 20:05:30 -- 1067288 Kbytes
IBM Informix Dynamic Server Version 11.70.F      -- On-Line -- Up 20:05:35 -- 1067288 Kbytes
```

Figure 21-142. command output

Example output running the `onstat -r` command every ten seconds

```
onstat -r 10
IBM Informix Dynamic Server Version 11.50.F      -- On-Line -- Up 20:06:58 -- 1067288 Kbytes
IBM Informix Dynamic Server Version 11.50.F      -- On-Line -- Up 20:07:08 -- 1067288 Kbytes
IBM Informix Dynamic Server Version 11.50.F      -- On-Line -- Up 20:07:18 -- 1067288 Kbytes
```

Figure 21-143. command output

Example output running the `onstat -r` every one second, with the **-h** option

```

onstat -r 1 -h

Buffer pool page size: 2048

buffer hash chain length histogram
# of chains      of len
      3841         0
      3767         1
       522         2
         62         3
      8192 total chains
      4351 hashed buffs
      5000 total buffs

Buffer pool page size: 2048

buffer hash chain length histogram
# of chains      of len
      4020         0
      3392         1
       735         2
         43         3
          2         4
      8192 total chains
      4172 hashed buffs
      5000 total buffs

```

Figure 21-144. `onstat -r 1 -h` command output

Example output running the `onstat -r` command every five seconds, with the `-Fh` options

```

onstat -rFh

Fg Writes      LRU Writes    Chunk Writes
0              0             21

address        flusher state  data  # LRU  Chunk  Wakeups  Idle Tim
460e6820      0          I      0     0      2      5        9.820
      states: Exit Idle Chunk Lru

Buffer pool page size: 2048

buffer hash chain length histogram
# of chains    of len
6342           0
1850           1
8192 total chains
1850 hashed buffs
5000 total buffs

Fg Writes      LRU Writes    Chunk Writes
0              0             21

address        flusher state  data  # LRU  Chunk  Wakeups  Idle Tim
460e6820      0          I      0     0      2      10       22.755
      states: Exit Idle Chunk Lru

Buffer pool page size: 2048

buffer hash chain length histogram
# of chains    of len
4396           0
3796           1
8192 total chains
3796 hashed buffs
5000 total buffs

```

Figure 21-145. **onstat -rFh** command output

onstat -R command: Print LRU, FLRU, and MLRU queue information

Use the **onstat -R** command to display detailed information about the LRU queues, FLRU queues, and MLRU queues. For each queue, the **onstat -R** command displays the number of buffers in the queue and the number and percentage of buffers that have been modified.

For an in-depth discussion of the three types of queues, see LRU queues in the shared-memory chapter of the *IBM Informix Administrator's Guide*.

Syntax:

▶▶ onstat -R ◀◀

Example output

```

Buffer pool page size: 2048
8 buffer LRU queue pairs          priority levels
# f/m  pair total  % of  length  LOW  HIGH
0 f     375      100.0%  375    375   0
1 m           0.0%    0         0     0
2 f     375      100.0%  375    375   0
3 m           0.0%    0         0     0
4 f     375      100.0%  375    375   0
5 m           0.0%    0         0     0
6 F     375      100.0%  375    375   0
7 m           0.0%    0         0     0
8 f     375      100.0%  375    375   0
9 m           0.0%    0         0     0
10 f    375      100.0%  375    375   0
11 m           0.0%    0         0     0
12 f    375      100.0%  375    375   0
13 m           0.0%    0         0     0
14 f    375      100.0%  375    375   0
15 m           0.0%    0         0     0
0 dirty, 3000 queued, 3000 total, 4096 hash buckets, 2048 buffer size
start clean at 60.000% (of pair total) dirty, or 226 buffs dirty, stop at
50.000%
Buffer pool page size: 8192
4 buffer LRU queue pairs          priority levels
# f/m  pair total  % of  length  LOW  HIGH
0 F     250      100.0%  250    250   0
1 m           0.0%    0         0     0
2 f     250      100.0%  250    250   0
3 m           0.0%    0         0     0
4 f     250      100.0%  250    250   0
5 m           0.0%    0         0     0
6 f     250      100.0%  250    250   0
7 m           0.0%    0         0     0
0 dirty, 1000 queued, 1000 total, 1024 hash buckets, 8192 buffer size
start clean at 60.000% (of pair total) dirty, or 150 buffs dirty, stop at
50.000%

```

Figure 21-146. **onstat -R** command output

Output description

Buffer pool page size

Is the page size of the buffer pool in bytes

Shows the queue number

Each LRU queue is composed of two subqueues: an FLRU queue and a MLRU queue. (For a definition of FLRU and MLRU queues, see LRU queues in the shared-memory chapter of the *IBM Informix Administrator's Guide*.) Thus, queues 0 and 1 belong to the first LRU queue, queues 2 and 3 belong to the second LRU queue, and so on.

f/m Identifies queue type

This field has four possible values:

f Free LRU queue

In this context, free means not modified. Although nearly all the buffers in an LRU queue are available for use, the database server attempts to use buffers from the FLRU queue rather than the MLRU queue. (A modified buffer must be written to disk before the database server can use the buffer.)

F Free LRU with fewest elements

The database server uses this estimate to determine where to put unmodified (free) buffers next.

- m** MLRU queue
- M** MLRU queue that a flusher is cleaning

length Tracks the length of the queue measured in buffers

% of Shows the percent of LRU queue that this subqueue composes

For example, suppose that an LRU queue has 50 buffers, with 30 of those buffers in the MLRU queue and 20 in the FLRU queue. The **% of** column would list percents of 60.00 and 40.00, respectively.

pair total

Provides the total number of buffers in this LRU queue

priority levels

Displays the priority levels: LOW, MED_LOW, MED_HIGH, HIGH

The **onstat -R** command also lists the priority levels.

Summary information follows the individual LRU queue information. You can interpret the summary information as follows:

dirty Is the total number of buffers that have been modified in all LRU queues

queued Is the total number of buffers in LRU queues

total Is the total number of buffers

hash buckets

Is the number of hash buckets

buffer size

Is the size of each buffer

start clean

Is the value specified in the **lru_max_dirty** field of the BUFFERPOOL configuration parameter

stop at Is the value specified in the **lru_min_dirty** field of the BUFFERPOOL configuration parameter

priority downgrades

Is the number of LRU queues downgraded to a lower priority.

priority upgrades

Is the number of LRU queues upgraded to a higher priority.

onstat -s command: Print latch information

Use the **onstat -s** command to display general latch information, including the resource that the latch controls.

Syntax:

►► onstat -s ◀◀

Example output

Latches with lock or userthread set
name address lock wait userthread

Figure 21-147. **onstat -s** command output

Output description

name Identifies the resource that the latch controls with the following abbreviations:

- archive** Storage-space backup
- bf** Buffers
- bh** Hash buffers
- chunks** Chunk table
- ckpt** Checkpoints
- dbspace** Dbspace table
- flushctl** Page-flusher control
- flushr** Page cleaners
- locks** Lock table
- loglog** Logical log
- LRU** LRU queues
- physb1** First physical-log buffer
- physb2** Second physical-log buffer
- physlog** Physical log
- pt** Tblspace tblspace
- tblsps** Tblspace table
- users** User table

address Is the address of the latch

This address appears in the **onstat -u** (users) command output wait field if a thread is waiting for the latch.

lock Indicates if the latch is locked and set

The codes that indicate the lock status (1 or 0) are computer dependent.

wait Indicates if any user thread is waiting for the latch

userthread

Is the shared-memory address of any user thread that is waiting for a latch

Instead this field contains the thread-control block address, which all threads have. You can compare this address with the user addresses in the **onstat -u** output to obtain the user-process identification number.

0x00000100	Simple large objects in blobspaces are not deleted when the table is dropped
0x00000200	Partition alter page count is updated
0x00000400	Pages have been altered to the latest database schema
0x00000800	System temp table
0x00001000	User temp table
0x00004000	Index operations are deferred during recovery
0x00008000	Partition is being truncated
0x00010000	Partition is partially truncated
<i>ucnt</i>	Is the usage count, which indicates the number of user threads currently accessing the tblspace
<i>tblnum</i>	Is the tblspace number expressed as a hexadecimal value The integer equivalent appears as the partnum value in the systables system catalog table.
<i>physaddr</i>	Is the physical address (on disk) of the tblspace
<i>npages</i>	Is the number of pages allocated to the tblspace
<i>nused</i>	Is the number of used pages in the tblspace
<i>npdata</i>	Is the number of data pages used
<i>nrows</i>	Is the number of data rows used
<i>nextns</i>	Is the number of noncontiguous extents allocated This number is not the same as the number of times that a next extent has been allocated.

onstat -u command: Print user activity profile

Use the **onstat -u** command to display a profile of user activity.

Syntax:

▶▶ onstat -u ◀◀

Example output

Userthreads									
address	flags	sessid	user	tty	wait	tout	locks	nreads	nwrites
a4d8018	---P--D	1	informix	-	0	0	0	58	4595
a4d8628	---P--F	0	informix	-	0	0	0	0	2734
a4d8c38	---P---	5	informix	-	0	0	0	0	1
a4d9248	---P--B	6	informix	-	0	0	0	40	0
a4d9858	---P--D	7	informix	-	0	0	0	0	0
a4d9e68	Y--P---	21	niraj	-	a65e5a8	0	1	0	0
6 active, 128 total, 7 maximum concurrent									

Figure 21-149. **onstat -u** command output

Output description

The **-u** option displays the following output for each user thread.

address The shared-memory address of the user thread in the user table.

Compare this address with the addresses displayed in the output from the **-s** option (latches); the output from the **-b**, **-B**, and **-X** options (buffers); and the output from the **-k** option (locks) to learn what resources this thread is holding or waiting for.

flags Provides the status of the session.

The flag codes for position 1:

- B** Waiting for a buffer
- C** Waiting for a checkpoint
- G** Waiting for a write of the logical-log buffer
- L** Waiting for a lock
- S** Waiting for mutex
- T** Waiting for a transaction
- Y** Waiting for condition
- X** Waiting for a transaction cleanup (rollback)

DEFUNCT

The thread has incurred a serious assertion failure, and has been suspended to allow other threads to continue their work.

The flag code for position 2:

- *** Transaction active during an I/O failure

The flag code for position 3:

- A** A dbspace backup thread

For other values that appear here, see the third position of flag codes for the **-x** option.

The flag code for position 4:

- P** Primary thread for a session

The flag codes for position 5:

- R** Reading
- X** Thread in critical section

The flag codes for position 6:

- R Thread used in recovery (for example, physical or logical recovery)
- Thread not used in recovery

The flag codes for position 7:

- B A B-tree cleaner thread
- C Terminated user thread waiting for cleanup
- D A daemon thread
- F A page-cleaner thread
- M Special ON-Monitor thread (UNIX)

sessid The session identification number.

During operations such as parallel sorting and parallel index building, a session might have many user threads associated with it. For this reason, the session ID identifies each unique session.

user The user login name, which is derived from the operating system

tty The name of the standard error (stderr) file that the user is using, which is derived from the operating system.

This field is blank on Windows.

wait If the user thread is waiting for a specific latch, lock, mutex, or condition, this field displays the address of the resource. Use this address to map to information provided in the output from the **-s** (latch) option or the **-k** (lock) option. If the wait is for a persistent condition, run a **grep** for the address in the output from the **onstat -a** command.

tout The number of seconds left in the current wait

If the value is 0, the user thread is not waiting for a latch or lock. If the value is -1, the user thread is in an indefinite wait.

locks The number of locks that the user thread is holding

The **-k** output should include a listing for each lock held.)

nreads The number of disk reads that the user thread has executed

nwrites

The number of write calls that the user thread has executed

All write calls are writes to the shared-memory buffer cache.

The last line of the **onstat -u** command output displays the maximum number of concurrent user threads that were allocated since you initialized the database server. For example, the last line of a sample **onstat -u** command output is as follows:

```
4 active, 128 total, 17 maximum concurrent
```

The last part of the line, 17 maximum concurrent, indicates that the maximum number of user threads that were running concurrently since you initialized the database server is 17.

The output also indicates the number of active users and the maximum number of users allowed.

onstat -x command: Print database server transaction information

Use the **onstat -x** command to display transaction information on the database server.

Syntax:

```
▶▶ onstat -x ◀◀
```

The transaction information is required only in the following situations:

- X/Open environment
- Database server participation in distributed queries
- Database server uses the Microsoft Transaction Server (MTS) transaction manager

Example output

Transactions								
address	flags	userthread	locks	begin logpos	current logpos	isol	est. rb_time	retrys coord
a6d8028	A----	a695028	0	-	-	COMMIT	-	0
a6d8348	A----	a695878	0	-	-	COMMIT	-	0
a6d8668	A----	a6960c8	0	-	-	COMMIT	-	0
a6d8988	A----	a696918	0	-	-	COMMIT	-	0
a6d8fc8	A----	a698208	0	-	-	COMMIT	-	0
a6d92e8	A----	a6979b8	0	-	-	COMMIT	-	0
a6d9608	A----	a698a58	0	-	-	COMMIT	-	0
a6d9928	A----	a6992a8	1	-	-	DIRTY	-	0
a6d9c48	A----	a6992a8	0	-	-	NOTRANS	-	0
a6d9f68	A----	a69a348	0	-	-	COMMIT	-	0
a6da288	A----	a69ab98	0	-	-	COMMIT	-	0
a6da5a8	A----	a69b3e8	0	-	-	COMMIT	-	0
a6da8c8	A----	a69bc38	0	-	-	COMMIT	-	0
a6dabe8	A----	a69c488	0	-	-	COMMIT	-	0
a6daf08	A----	a699af8	0	-	-	COMMIT	-	0
a6db228	A----	a6992a8	0	-	-	COMMIT	-	0
a6db548	A----	a69ccd8	1	-	-	DIRTY	-	0
a6db868	A----	a69d528	1	-	-	DIRTY	-	0
a6dbb88	A----	a69ccd8	0	-	-	COMMIT	-	0
a6dbea8	A----	a69dd78	0	-	-	COMMIT	-	0
a6dc1c8	A----	a69e5c8	0	-	-	COMMIT	-	0
a6dc4e8	A-B--	a69ee18	502	33:0x25018	34:0x486fc	COMMIT	0:07	0

22 active, 128 total, 23 maximum concurrent

Figure 21-150. **onstat -x** command output

Output description

You can interpret output from the **onstat -x** command as follows:

address

The shared-memory address of the transaction structure

flags

The flag codes for position 1 (current transaction state):

A User thread attached to the transaction

S TP/XA suspended transaction

C TP/XA waiting for rollback

The flag codes for position 2 (transaction mode):

T Tightly-coupled mode (MTS)

L Loosely-coupled mode (default mode)

The flag codes for position 3 (transaction stage):

B Begin work

P Distributed query prepared for commit

X TP/XA prepared for commit

C Committing or committed

R Rolling back or rolled back

H Heuristically rolling back or rolled back

The flag code for position 4:

X XA transaction

The flag codes for position 5 (type of transaction):

G Global transaction

C Distributed query coordinator

S Distributed query subordinate

B Both distributed query coordinator and subordinate

M Redirected global transaction

userthread

The thread that owns the transaction (**rstcb** address)

locks The number of locks that the transaction holds

begin logpos

The position within the log when the BEGIN WORK record was logged.

current logpos

The current log position of the most recent record that the transaction is wrote too (As a transaction rolls back, the current log position will actually wind back until it gets to the beginning log position. When the beginning log position is reached, the rollback is complete.)

isol The isolation level.

est. rb time

The estimated time the server needs to rollback the transaction. As a transaction goes forward, this time increases. If a transaction rolls back, the time decreases as the transaction unwinds.

retrys Are the attempts to start a recovery thread for the distributed query

coord The name of the transaction coordinator when the subordinate is executing the transaction

This field tells you which database server is coordinating the two-phase commit.

The last line of the **onstat -x** command output indicates that 8 is the maximum number of concurrent transactions since you initialized the database server.

8 active, 128 total, 8 maximum concurrent

Determine the position of a logical-log record

Use the **onstat -x** command to determine the position of a logical-log record.

The **curlog** and **logposit** fields provide the exact position of a logical-log record. If a transaction is not rolling back, **curlog** and **logposit** describe the position of the most recently written log record. When a transaction is rolling back, these fields describe the position of the most recently “undone” log record. As the transaction rolls back, the **curlog** and **logposit** values decrease. In a long transaction, the rate at which the **logposit** and **beginlg** values converge can help you estimate how much longer the rollback is going to take.

For an **onstat -x** command example, see monitoring a global transaction in the chapter on multiphase commit protocols in the *IBM Informix Administrator’s Guide*.

Determine the mode of a global transaction

The **onstat -x** command is useful for determining whether a global transaction is executing in loosely-coupled or tightly-coupled mode.

The second position of the flags column in the output from the **onstat -x** command displays the flags for global transactions. The T flag indicates tightly-coupled mode and the L flag indicates loosely-coupled mode.

- *Loosely-coupled mode* means that the different database servers coordinate transactions but do not share locks. Each branch in a global transaction has a separate transaction XID. The records from all branches display as separate transactions in the logical log.
- *Tightly-coupled mode* means that the different database servers coordinate transactions and share resources such as locking and logging. In a global transaction, all branches that access the same database share the same transaction XID. Log records for branches with the same XID appear under the same session ID. MTS uses tightly-coupled mode.

onstat -X command: Print thread information

Use the **onstat -X** command to obtain precise information about the threads that are waiting for buffers.

For each buffer in use, the **onstat -X** command displays general buffer information that is also available with either the **onstat -b** or **onstat -B** commands. For more information, refer to the **onstat -b** command in “**onstat -b** command: Print buffer information for buffers in use” on page 21-25.

Syntax:

►► onstat -X ◀◀

Example output

```

Buffers (Access)
address owner  flags pagenum          memaddr  nslots pgflgs scout  waiter
Buffer pool page size: 2048
0 modified, 3000 total, 4096 hash buckets, 2048 buffer size
Buffer pool page size: 8192
0 modified, 1000 total, 1024 hash buckets, 8192 buffer size

```

Figure 21-151. **onstat -X** command output

Output description

The **onstat -X** command has a **waiter** field to list all user threads that are waiting for the buffer, whereas the **onstat -b** and **onstat -B** commands contain a **waitlist** field that displays the address of the first user thread that is waiting for the buffer. The maximum number of shared buffers is specified in the **buffers** field in the BUFFERPOOL configuration parameter in the ONCONFIG file.

Buffer pool page size

The size of the buffer pool pages in bytes

address

The address of the buffer header in the buffer table

flags Flags identifying the current status of the buffer page:

- 0x01 Modified Data
- 0x02 Data
- 0x04 LRU
- 0x08 Error
- 0x10 Shared lock
- 0x20 LRU AIO write in progress
- 0x40 Chunk write in progress
- 0x10 Exclusive lock
- 0x100 Cleaner assigned to LRU
- 0x200 Buffer should avoid bf_check calls
- 0x400 Do log flush before writing page
- 0x800 Buffer has been 'buff' -checked
- 0x8000 Buffer has been pinned

pagenum

The physical page number on the disk

memaddr

The buffer memory address

nslots The number of slot-table entries in the page

This field indicates the number of rows (or portions of a row) that are stored on the page.

pgflgs Uses the following values, alone or in combination, to describe the page type:

- 1 Data page
- 2 Tblspace page
- 4 Free-list page

8	Chunk free-list page
9	Remainder data page
b	Partition resident blobpage
c	Blobspace resident blobpage
d	Blob chunk free-list bit page
e	Blob chunk blob map page
10	B-tree node page
20	B-tree root-node page
40	B-tree branch-node page
80	B-tree leaf-node page
100	Logical-log page
200	Last page of logical log
400	Sync page of logical log
800	Physical log
1000	Reserved root page
2000	No physical log required
8000	B-tree leaf with default flags

scout Displays the number of threads that are waiting for the buffer

waiter Lists the addresses of all user threads that are waiting for the buffer

onstat -z command: Clear statistics

Use the **onstat -z** command to clear database server statistics, including statistics that relate to Enterprise Replication, and set the profile counts to 0.

If you use the **onstat -z** command to reset and monitor the count of some fields, be aware that profile counts are incremented for all activity that occurs in any database that the database server manages. Any user can reset the profile counts and thus interfere with monitoring that another user is conducting.

Syntax:

```
▶▶ onstat -z ◀◀
```

Return codes on exiting the onstat utility

The **onstat** utility displays a set of return codes when you exit the utility.

Example

The following lines are an example of the messages and return codes that are displayed when you exit the **onstat** utility:

```
GLS failures: -1
Failed to attach shared memory: -1
Failed to attach shared memory when running 'onstat -': 255
All other errors detected by onstat: 1
No errors detected by onstat: 0
Administration mode: 7
```

Return code values

The following table lists the database server mode that corresponds to the return codes that are displayed when you exit the **onstat** utility.

Value	Explanation
-1	GLS locale initialization failed or Informix failed to attach to shared memory
0	Initialization mode
1	Quiescent mode
2	Recovery mode
3	Backup mode
4	Shutdown mode
5	Online mode
6	Abort mode
7	User mode
255	Off-Line mode

Part 3. SQL Administration API

Chapter 22. SQL Administration API Functions

These topics describe the SQL administration API **admin()** and **task()** functions.

SQL Administration API Overview

Use the SQL administration API to remotely administer Informix through SQL statements.

The SQL administration API consists of two functions: **admin()** and **task()**. These functions perform the same operations, but return results in different formats. These functions take one or more arguments that define the operation. Many of the operations are ones that you can also complete with command line utilities. The advantage of using the SQL administration API functions is that you can run them remotely from other database servers; whereas you must be directly connected to the database server on which to run command line utility commands.

You can invoke the **admin()** and **task()** functions within SQL statements that can include an expression, or you can use the EXECUTE FUNCTION statement to call them.

The SQL administration API functions are defined in the **sysadmin** database. You must be connected to the **sysadmin** database, either directly or remotely, to run these functions.

The SQL administration API functions can be run only by the following users:

- The user **informix**
- The **root** user, if Connect privilege on the **sysadmin** database is granted to the user
- The DBSA group members, if Connect privilege on the **sysadmin** database is granted to the role

You can generate SQL administration API commands for reproducing the storage spaces, chunks, and logs that exist in a file. To do this, run the **dbschema** utility with the **-c** option.

admin() and **task()** Function Syntax Behavior

The **admin()** and **task()** functions take one or more arguments as quoted strings separated by commas.

The syntax for the **admin()** and **task()** functions includes the following rules:

- Each argument must be delimited by a pair of single (') quotation marks or double (") quotation marks.
- Arguments must be separated by a comma.
- The maximum number of arguments is 28.
- Most arguments are not case-sensitive, with the following exceptions:
 - The argument that immediately follows the initial **onmode** argument is case-sensitive.

For example:

```
EXECUTE FUNCTION task("onmode","D","50");
```

- The arguments included with the **cdr** argument are case-sensitive.

For example:

```
EXECUTE FUNCTION task("cdr define server",
  "-C=g_amsterdam","--init g_amsterdam");
```

- If you are not directly connected to the **sysadmin** database, you must include the **sysadmin** database name and the server name, according to the standard Database Object Name syntax. For example, if your server name is **ids_server**, you could run the following statement:

```
EXECUTE FUNCTION sysadmin@ids_server:admin("add bufferpool", "2",
  "50000", "8", "60.0", "50.0");
```

For more information on the Database Object Name syntax, see the *IBM Informix Guide to SQL: Syntax*.

admin() and task() Argument Size Specifications

By default, the units for arguments specifying sizes in **admin()** and **task()** functions are kilobytes. You can specify other units.

You can use the following units in size arguments to the **admin()** and **task()** functions:

Notation

Corresponding Units

B	Bytes
K	Kilobytes (Default)
M	Megabytes
G	Gigabytes
T	Terabytes
P	Petabytes

The letter case of these characters is ignored.

Any white space that separates the size specification and the units abbreviation in the same argument is ignored. For example, the specifications "128M" and "128 m" are both interpreted as 128 megabytes.

When a size argument is omitted, the default size for that object applies, based either on the setting of a configuration parameter, or on the system default if no parameter is set. Storage spaces, for example, have a default size of 100 megabytes.

admin() and task() Function Return Codes

The **admin()** and **task()** functions perform equivalent tasks but produce different types of return codes. Use the **admin()** function if you want an integer return code, or the **task()** function if you want a textual return code.

When you run the **admin()** or **task()** function, it:

- Performs the specified operation.
- Returns a value that signifies whether the function succeeded or failed.
- Inserts a row into the **command_history** table of the **sysadmin** database.

The return codes for the **admin()** and **task()** functions indicate whether the function succeeded or failed in different formats:

- The **task()** function returns a textual message. The message is also inserted into the **cmd_ret_msg** column in the new row that the **task()** function inserts into the **command_history** table.
- The **admin()** function returns an integer. This number is also inserted into the **cmd_number** column in the new row that the **admin()** function inserts into the **command_history** table.
 - If this value is greater than zero, the function succeeded, and a new row was inserted into the **command_history** table.
 - If this value is zero, the function succeeded, but Informix could not insert a new row into the **command_history** table.
 - If this value is less than zero, the function failed, but a new row was inserted into the **command_history** table.

The operation that the **admin()** or **task()** function specifies occurs in a separate transaction from the insertion of the new row into the **command_history** table. If the command executes successfully, but the insertion into the **command_history** table fails, the command takes effect, but an **online.log** error entry indicates the problem.

If the **command_history.cmd_number** serial counter is 200 when this function is called, and the command succeeds, then Informix executes the command and returns the integer 201. If the command fails, this example returns the value -201.

Suppose the **task()** function had executed the same command:

```
EXECUTE FUNCTION task("check extents");
```

This command instructs the database server to check the extents, and returns a message indicating whether the command succeeded or failed.

If the **command_history.cmd_number** serial counter is 201 when this function is called, and the command fails, then the returned value is -202. Suppose that the next SQL administration API function that the DBSA invokes is this:

```
EXECUTE FUNCTION admin('create dbspace',  
    'dbspace2', '/work/CHUNKS/dbspace2', "20M");
```

If in this case the command succeeds, the returned value is 203. The DBSA can use the following query to examine the two rows of the **command_history** table that these calls to the **admin()** function inserted:

```
SELECT * FROM command_history WHERE cmd_number IN (202,203);
```

This query returns two rows:

```
cmd_number      202  
cmd_exec_time   2009-04-17 16:26:14  
cmd_user        informix  
cmd_hostname    olympia  
cmd_executed    create dbspace  
cmd_ret_status  -1  
cmd_ret_msg     Unable to create file /work/dbspace2  
  
cmd_number      203  
cmd_exec_time   2009-04-17 16:26:15  
cmd_user        informix  
cmd_hostname    olympia
```



```

cmd_executed      create dbspace
cmd_ret_status    0
cmd_ret_msg       created dbspace number 2 named dbspace2

```

SQL administration API portal: Arguments by functional category

You can view a list of **admin()** and **task()** function arguments, sorted by category, with links to information about the arguments.

Category list

To use this section, you first determine the appropriate category from the following list, then follow the link to the SQL administration API function arguments for that category.

- “Compression arguments”
- “Configuration parameter arguments” on page 22-5
- “Data, partition, and extent arguments” on page 22-6
- “Database arguments” on page 22-5
- “Enterprise replication arguments” on page 22-6
- “High availability arguments” on page 22-6
- “Listen thread arguments” on page 22-7
- “Log arguments” on page 22-7
- “Message log arguments” on page 22-8
- “Memory arguments” on page 22-8
- “Mirror arguments” on page 22-9
- “Parallel database query (PDQ) arguments” on page 22-9
- “Server mode arguments” on page 22-9
- “Space arguments” on page 22-10
- “Storage provisioning arguments” on page 22-11
- “SQL tracing arguments” on page 22-12
- “Miscellaneous arguments” on page 22-13

Backup arguments

Use the following SQL administration API function arguments to backup your databases.

Table 22-1. admin() and task() Function Arguments for Databases

Argument	When Added to Informix
“ontape archive argument: Backup the data on your database (SQL administration API)” on page 22-96	Version 11.70.xC2
“onbar argument: Backup the storage spaces (SQL administration API)” on page 22-93	Version 11.70.xC2
“onsmsync argument: Synchronize with the storage manager catalog (SQL administration API)” on page 22-95	Version 11.70.xC2

Compression arguments

Use the following SQL administration API function arguments to manage the compression of data and to optimize storage.

Table 22-2. admin() and task() Function Arguments for Compression Commands

Argument	When Added to Informix
“table or fragment arguments: Compress data and optimize storage (SQL administration API)” on page 22-127	Version 11.50xC4
“table or fragment arguments: Compress data and optimize storage (SQL administration API)” on page 22-127	Version 11.50xC4
“purge compression dictionary arguments: Remove compression dictionaries (SQL administration API)” on page 22-133	Version 11.50xC4

For an overview of compression and storage optimization commands, see “Table and fragment compress and uncompress operations (SQL administration API)” on page 22-126.

Configuration parameter arguments

Use the following SQL administration API function arguments to update configuration parameters.

Table 22-3. admin() and task() Function Arguments for Configuration Parameter Commands

Argument	When Added to Informix
“onmode and wf arguments: Permanently update a configuration parameter (SQL administration API)” on page 22-88	Version 11.10.xC1
“onmode and wm arguments: Temporarily update a configuration parameter (SQL administration API)” on page 22-89	Version 11.10.xC1
“onmode, wm, and AUTO_LRU_TUNING arguments: Change LRU tuning status (SQL administration API)” on page 22-90	Version 11.10.xC1
“set onconfig memory argument: Temporarily change a configuration parameter (SQL administration API)” on page 22-108	Version 11.50.xC3
“set onconfig permanent argument: Permanently change a configuration parameter (SQL administration API)” on page 22-109	Version 11.50.xC3

Database arguments

Use the following SQL administration API function arguments to create and drop databases.

Table 22-4. admin() and task() Function Arguments for Databases

Argument	When Added to Informix
“create database argument: Create a database (SQL administration API)” on page 22-31	Version 11.70.xC2
“drop database argument: Drop a database (SQL administration API)” on page 22-46	Version 11.70.xC2

Data, partition, and extent arguments

Use the following SQL administration API function arguments to manage data, partitions, and extents.

Table 22-5. admin() and task() Function Arguments for Data, Partition, and Extent Commands

Argument	When Added to Informix
"onmode and C arguments: Control the B-tree scanner (SQL administration API)" on page 22-74	Version 11.10.xC1
"onmode and c arguments: Force a checkpoint (SQL administration API)" on page 22-73	Version 11.10.xC1
"check data argument: Check data consistency (SQL administration API)" on page 22-23	Version 11.10.xC1
"check extents argument: Check extent consistency (SQL administration API)" on page 22-24	Version 11.10.xC1
"check partition argument: Check partition consistency (SQL administration API)" on page 22-24	Version 11.10.xC1
"checkpoint argument: Force a checkpoint (SQL administration API)" on page 22-25	Version 11.10.xC1
"print partition argument: Print partition information (SQL administration API)" on page 22-99	Version 11.10.xC1
"set dataskip argument: Start or stop skipping a dbspace (SQL administration API)" on page 22-107	Version 11.10.xC1
"set index compression argument: Change index page compression (SQL administration API)" on page 22-107	Version 11.50.xC2

Enterprise replication arguments

Use the following SQL administration API function arguments to manage Enterprise Replication.

Table 22-6. admin() and task() Function Arguments for Enterprise Replication Commands

Argument	When Added to Informix
"cdr argument: Administer Enterprise Replication (SQL administration API)" on page 22-22	Version 11.50.xC3

High availability arguments

Use the following SQL administration API function arguments to manage high-availability replication (HDR).

Table 22-7. admin() and task() Function Arguments for HDR Commands

Argument	When Added to Informix
"archive fake argument: Perform an unrecorded backup (SQL administration API)" on page 22-21	Version 11.50.xC1
"ha make primary argument: Change the mode of a secondary server (SQL administration API)" on page 22-53	Version 11.50.xC1
"ha rss argument: Create an RS secondary server (SQL administration API)" on page 22-54	Version 11.50.xC1

Table 22-7. admin() and task() Function Arguments for HDR Commands (continued)

Argument	When Added to Informix
“ha rss add argument: Add an RS secondary server to a primary server (SQL administration API)” on page 22-55	Version 11.50.xC1
“ha rss change argument: Change the password of an RS secondary server (SQL administration API)” on page 22-56	Version 11.50.xC1
“ha rss delete argument: Delete an RS secondary server (SQL administration API)” on page 22-57	Version 11.50.xC1
“ha sds clear argument: Stop shared-disk replication (SQL administration API)” on page 22-57	Version 11.50.xC1
“ha sds primary argument: Convert an SD secondary server to a primary server (SQL administration API)” on page 22-58	Version 11.50.xC1
“ha sds set argument: Create a shared-disk primary server (SQL administration API)” on page 22-59	Version 11.50.xC1
“ha set idxauto argument: Replicate indexes to secondary servers (SQL administration API)” on page 22-60	Version 11.50.xC1
“ha set ipl argument: Log index builds on the primary server (SQL administration API)” on page 22-60	Version 11.50.xC1
“ha set primary argument: Define an HDR primary server (SQL administration API)” on page 22-61	Version 11.50.xC1
“ha set secondary argument: Define an HDR secondary server (SQL administration API)” on page 22-62	Version 11.50.xC1
“ha set standard argument: Convert an HDR server into a standard server (SQL administration API)” on page 22-62	Version 11.50.xC1
“ha set timeout argument: Change SD secondary server timeout (SQL administration API)” on page 22-63	Version 11.50.xC1
“onmode and d arguments: Set data-replication types (SQL administration API)” on page 22-75	Version 11.50.xC1

Listen thread arguments

Use the following SQL administration API function arguments to control listen threads for a SOCTCP or TLITCP network protocol without interrupting existing connections.

Table 22-8. admin() and task() Function Arguments for Listen Thread Commands

Argument	When Added to Informix
“restart listen argument: Stop and start a listen thread dynamically (SQL administration API)” on page 22-101	Version 11.50.xC6
“start listen argument: Start a listen thread dynamically (SQL administration API)” on page 22-117	Version 11.50.xC6
“stop listen argument: Stop a listen thread dynamically (SQL administration API)” on page 22-118	Version 11.50.xC6

Log arguments

Use the following SQL administration API function arguments to manage logical and physical logs.

Table 22-9. admin() and task() Function Arguments for Log Commands

Argument	When Added to Informix
“add log argument: Add a new logical log (SQL administration API)” on page 22-16	Version 11.10.xC1
“alter logmode argument: Change the database logging mode (SQL administration API)” on page 22-20	Version 11.10.xC1
“alter plog argument: Change the physical log (SQL administration API)” on page 22-21	Version 11.10.xC1
“drop log argument: Drop a logical log (SQL administration API)” on page 22-48	Version 11.10.xC1
“onmode and l arguments: Switch to the next logical log (SQL administration API)” on page 22-80	Version 11.10.xC1

Message log arguments

Use the following SQL administration API function arguments to manage message logs.

Table 22-10. admin() and task() Function Arguments for Message Log Commands

Argument	When Added to Informix
“file status argument: Display the status of a message log file (SQL administration API)” on page 22-52	Version 11.10.xC3
“message log rotate argument: Rotate the message log file (SQL administration API)” on page 22-64	Version 11.10.xC3
“message log delete argument: Delete a message log file (SQL administration API)” on page 22-64	Version 11.10.xC3
“message log truncate argument: Delete the contents of a message log file (SQL administration API)” on page 22-65	Version 11.10.xC3

Memory arguments

Use the following SQL administration API function arguments to manage memory.

Table 22-11. admin() and task() Function Arguments for Memory Commands

Argument	When Added to Informix
“add bufferpool argument: Add a buffer pool (SQL administration API)” on page 22-13	Version 11.10.xC1
“add memory argument: Increase shared memory (SQL administration API)” on page 22-17	Version 11.10.xC1
“onmode and a arguments: Add a shared-memory segment (SQL administration API)” on page 22-72	Version 11.10.xC1
“onmode and F arguments: Free unused memory segments (SQL administration API)” on page 22-78	Version 11.10.xC1
“onmode and n arguments: Unlock resident memory (SQL administration API)” on page 22-82	Version 11.10.xC1
“onmode and r arguments: Force residency of shared memory (SQL administration API)” on page 22-85	Version 11.10.xC1
“scheduler lmm enable argument: Specify automatic low memory management settings (SQL administration API)” on page 22-102	Version 11.70.xC3

Table 22-11. **admin()** and **task()** Function Arguments for Memory Commands (continued)

Argument	When Added to Informix
“scheduler Imm disable argument: Stop automatic low memory management (SQL administration API)” on page 22-105	Version 11.70.xC3

Mirror arguments

Use the following SQL administration API function arguments to manage mirroring.

Table 22-12. **admin()** and **task()** Function Arguments for Mirror Commands

Argument	When Added to Informix
“add mirror argument: Add a mirror chunk (SQL administration API)” on page 22-18	Version 11.10.xC1
“start mirroring argument: Starts storage space mirroring (SQL administration API)” on page 22-118	Version 11.10.xC1
“stop mirroring argument: Stops storage space mirroring (SQL administration API)” on page 22-119	Version 11.10.xC1

Parallel database query (PDQ) arguments

Use the following SQL administration API function arguments to manage PDQ.

Table 22-13. **admin()** and **task()** Function Arguments for PDQ Commands

Argument	When Added to Informix
“onmode and D arguments: Set PDQ priority (SQL administration API)” on page 22-77	Version 11.10.xC1
“onmode and M arguments: Temporarily change decision-support memory (SQL administration API)” on page 22-81	Version 11.10.xC1
“onmode and Q arguments: Set maximum number for decision-support queries (SQL administration API)” on page 22-84	Version 11.10.xC1
“onmode and S arguments: Set maximum number of decision-support scans (SQL administration API)” on page 22-86	Version 11.10.xC1

Server mode arguments

Use the following SQL administration API function arguments to change the server mode.

Table 22-14. **admin()** and **task()** Function Arguments for Server Mode Commands

Argument	When Added to Informix
“onmode and j arguments: Switch the database server to administration mode (SQL administration API)” on page 22-79	Version 11.10.xC1
“onmode and m arguments: Switch to multi-user mode (SQL administration API)” on page 22-80	Version 11.10.xC1

Space arguments

Use the following SQL administration API function arguments to manage chunks, blobspaces, dbspaces, and sbspaces.

Table 22-15. admin() and task() Function Arguments for Space Commands

Argument	When Added to Informix
"add chunk argument: Add a new chunk (SQL administration API)" on page 22-14	Version 11.10.xC1
"alter chunk argument: Change chunk status to online or offline (SQL administration API)" on page 22-19	Version 11.10.xC1
"clean sbspace argument: Release unreferenced smart large objects (SQL administration API)" on page 22-26	Version 11.10.xC1
"create blobspace argument: Create a blobspace (SQL administration API)" on page 22-26	Version 11.10.xC1
"create chunk argument: Create a chunk (SQL administration API)" on page 22-29	Version 11.10.xC1
"create dbspace argument: Create a dbspace (SQL administration API)" on page 22-32	Version 11.10.xC1
"create sbspace argument: Create an sbspace (SQL administration API)" on page 22-34	Version 11.10.xC1
"create sbspace with accesstime argument: Create an sbspace that tracks access time (SQL administration API)" on page 22-36	Version 11.70xC4
"create sbspace with log argument: Create an sbspace with transaction logging (SQL administration API)" on page 22-37	Version 11.70xC4
"create tempdbspace argument: Create a temporary dbspace (SQL administration API)" on page 22-38	Version 11.10.xC1
"create tempsbspace argument: Create a temporary sbspace (SQL administration API)" on page 22-40	Version 11.70xC4
"drop blobspace argument: Drop a blobspace (SQL administration API)" on page 22-43	Version 11.10.xC1
"drop chunk argument: Drop a chunk (SQL administration API)" on page 22-44	Version 11.10.xC1
"drop dbspace argument: Drop a dbspace (SQL administration API)" on page 22-47	Version 11.10.xC1
"drop sbspace argument: Drop an sbspace (SQL administration API)" on page 22-49	Version 11.10.xC1
"drop tempdbspace argument: Drop a temporary dbspace (SQL administration API)" on page 22-50	Version 11.10.xC1
"onmode and O arguments: Mark a disabled dbspace as down (SQL administration API)" on page 22-82	Version 11.10.xC1
"rename space argument: Rename a storage space (SQL administration API)" on page 22-99	Version 11.10.xC1
"set chunk argument: Change the status of a chunk (SQL administration API)" on page 22-106	Version 11.10.xC1
"set sbspace accesstime argument: Control access time tracking (SQL administration API)" on page 22-110	Version 11.10.xC1
"set sbspace avg_lo_size argument: Set the average size of smart large objects (SQL administration API)" on page 22-111	Version 11.10.xC1

Table 22-15. **admin()** and **task()** Function Arguments for Space Commands (continued)

Argument	When Added to Informix
“set sbspace logging argument: Change the logging of an sbspace (SQL administration API)” on page 22-112	Version 11.10.xC1

Storage provisioning arguments

Also use the following SQL administration API function arguments to manage chunks, blobspaces, dbspaces, and sbspaces.

Table 22-16. **admin()** and **task()** Function Arguments for Storage Provisioning Space Commands

Argument	When Added to Informix
“create blobspace from storagepool argument: Create a blobspace from the storage pool (SQL administration API)” on page 22-28	Version 11.70.xC1
“create chunk from storagepool argument: Create a chunk from the storage pool (SQL administration API)” on page 22-30	Version 11.70.xC1
“create dbspace from storagepool argument: Create a dbspace from the storage pool (SQL administration API)” on page 22-33	Version 11.70.xC1
“create sbspace from storagepool argument: Create an sbspace from the storage pool (SQL administration API)” on page 22-35	Version 11.70.xC1
“create tempdbspace argument: Create a temporary dbspace (SQL administration API)” on page 22-38	Version 11.70.xC1
“create tempsbspace from storagepool argument: Create a temporary sbspace from the storage pool (SQL administration API)” on page 22-41	Version 11.10.xC1
“create tempdbspace from storagepool argument: Create a temporary dbspace from the storage pool (SQL administration API)” on page 22-39	Version 11.70.xC1
“drop blobspace to storagepool argument: Return space from an empty blobspace to the storage pool (SQL administration API)” on page 22-44	Version 11.70.xC1
“drop chunk to storagepool argument: Return space from an empty chunk to the storage pool (SQL administration API)” on page 22-46	Version 11.70.xC1
“drop dbspace to storagepool argument: Return space from an empty dbspace to the storage pool (SQL administration API)” on page 22-47	Version 11.70.xC1
“drop sbspace to storagepool argument: Return space from an empty sbspace to the storage pool (SQL administration API)” on page 22-49	Version 11.70.xC1
“drop tempdbspace to storagepool argument: Return space from an empty temporary dbspace to the storage pool (SQL administration API)” on page 22-51	Version 11.70.xC1
“drop tempsbspace to storagepool argument: Return space from an empty temporary sbspace to the storage pool (SQL administration API)” on page 22-51	Version 11.70.xC1

Table 22-16. **admin()** and **task()** Function Arguments for Storage Provisioning Space Commands (continued)

Argument	When Added to Informix
"modify chunk extend argument: Extend the size of a chunk (SQL administration API)" on page 22-66	Version 11.70.xC1
"modify chunk extendable off argument: Mark a chunk as not extendable (SQL administration API)" on page 22-68	Version 11.70.xC1
"modify chunk extendable argument: Mark a chunk as extendable (SQL administration API)" on page 22-67	Version 11.70.xC1
"modify space expand argument: Expand the size of a space (SQL administration API)" on page 22-69	Version 11.70.xC1
"modify space sp_sizes argument: Modify the create or extend size of a storage space (SQL administration API)" on page 22-70	Version 11.70.xC1
"storagepool add argument: Add a storage pool entry (SQL administration API)" on page 22-120	Version 11.70.xC1
"storagepool modify argument: Modify a storage pool entry (SQL administration API)" on page 22-123	Version 11.70.xC1
"storagepool delete argument: Delete one storage pool entry (SQL administration API)" on page 22-122	Version 11.70.xC1
"storagepool purge argument: Delete storage pool entries (SQL administration API)" on page 22-125	Version 11.70.xC1

SQL statement cache arguments

Use the following SQL administration API function arguments to manage the SQL statement cache.

Table 22-17. **admin()** and **task()** Function Arguments for SQL Statement Cache Commands

Argument	When Added to Informix
"onmode and e arguments: Change usage of the SQL statement cache (SQL administration API)" on page 22-77	Version 11.10.xC1
"onmode and W arguments: Reset statement cache attributes (SQL administration API)" on page 22-86	Version 11.10.xC1

SQL tracing arguments

Use the following SQL administration API function arguments to manage SQL tracing.

Table 22-18. **admin()** and **task()** Function Arguments for SQL Tracing Commands

Argument	When Added to Informix
"set sql tracing argument: Set global SQL tracing (SQL administration API)" on page 22-112	Version 11.10.xC1
"set sql tracing database argument: Change database tracing (SQL administration API)" on page 22-114	Version 11.50.xC3
"set sql tracing session argument: Control tracing for a session (SQL administration API)" on page 22-115	Version 11.50.xC3
"set sql tracing user argument: Control tracing for users (SQL administration API)" on page 22-116	Version 11.10.xC1

Table 22-18. **admin()** and **task()** Function Arguments for SQL Tracing Commands (continued)

Argument	When Added to Informix
"set sql user tracing argument: Set global SQL tracing for a user session (SQL administration API)" on page 22-116	Version 11.50.xC3

Miscellaneous arguments

Use the following SQL administration API function arguments to manage miscellaneous processes.

Table 22-19. **admin()** and **task()** Function Arguments for Miscellaneous Commands

Argument	When Added to Informix
"onmode and e arguments: Change usage of the SQL statement cache (SQL administration API)" on page 22-77	Version 11.10.xC1
"onmode and p arguments: Add or remove virtual processors (SQL administration API)" on page 22-83	Version 11.10.xC1
"onmode and Y arguments: Change query plan measurements for a session (SQL administration API)" on page 22-91	Version 11.10.xC1
"onmode and z arguments: Terminate a user session (SQL administration API)" on page 22-92	Version 11.10.xC1
"onmode and Z arguments: Terminate a distributed transaction (SQL administration API)" on page 22-93	Version 11.10.xC1
"print error argument: Print an error message (SQL administration API)" on page 22-97	Version 11.10.xC1
"print file info argument: Display directory or file information (SQL administration API)" on page 22-98	Version 11.70.xC2
"reset sysadmin argument: Move the sysadmin database (SQL administration API)" on page 22-100	Version 11.10.xC1
"scheduler argument: Stop or start the scheduler (SQL administration API)" on page 22-102	Version 11.10.xC1

add bufferpool argument: Add a buffer pool (SQL administration API)

Use the **add bufferpool** argument with the **admin()** or **task()** function to create a buffer pool.

Syntax

```

▶▶ EXECUTE FUNCTION admin | task (
▶ "add bufferpool" —, — "pagesize" —, — "buffers" —
▶ , — "lrus" — , — "max_dirty" — , — "min_dirty" —
▶ ) —;

```

Element	Description	Key Considerations
<i>buffers</i>	The number of buffers. The default is 10000 buffers.	Each buffer is the size of the operating system page.
<i>lrus</i>	The number of LRU queues. The default is 8.	The maximum for 32-bit platforms is 128, and for 64-bit platforms is 512.
<i>max_dirty</i>	The percentage of modified pages in the LRU queues at which the queue is cleaned. If a field is specified out of the range of values, the default of 60.00 percent is set.	
<i>min_dirty</i>	The percentage of modified pages in the LRU queues at which page cleaning is not mandatory. Page cleaners might continue cleaning beyond this point under some circumstances. If a field is specified out of the range of values, the default of 80.00 percent is set.	
<i>pagesize</i>	The page size in kilobytes.	The page size must be an integral multiple of the default page size, and cannot be greater than 16 kilobytes. On Windows, the page size is always 4 kilobytes.

Usage

This function is equivalent to the **onparams -b -g** command and the BUFFERPOOL configuration parameter.

Example

The following example adds a bufferpool with a page size of 2 KB, 50,000 buffers, 8 LRU queues, an LRU maximum of 60 percent, and an LRU minimum of 50 percent:

```
EXECUTE FUNCTION task("add bufferpool", "2", "50000", "8", "60.0", "50.0");
```

Related reference:

“onparams -b: Add a new buffer pool” on page 17-4

“BUFFERPOOL configuration parameter” on page 1-36

add chunk argument: Add a new chunk (SQL administration API)

Use the **add chunk** argument with the **admin()** or **task()** function to add a chunk to a dbspace or blobspace.

Syntax

```
►► EXECUTE FUNCTION admin (task) ("add chunk", —, — "spacename" —, — "pathname" —) ►►
```

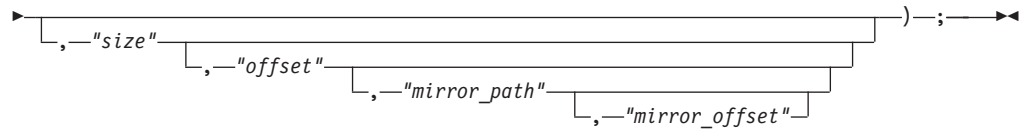

Element	Description	Key Considerations
<i>mirror_offset</i>	The location of the mirror chunk.	
<i>mirror_path</i>	The path to the mirror chunk.	If you are adding a chunk to a mirrored storage space, you must also add a mirror chunk.
<i>offset</i>	The location of the new chunk.	
<i>pathname</i>	The path of the added disk space.	
<i>size</i>	The amount of disk space to add in kilobytes.	See “admin() and task() Argument Size Specifications” on page 22-2.
<i>spacename</i>	The name of the dbspace, blobspace, or sbspace to which you are adding disk space.	

Usage

The size of the chunk must be equal to or greater than 1000 KB and a multiple of the page size. The starting offset plus the chunk size cannot exceed the maximum chunk size. The maximum offset is 4 TB.

This function is equivalent to the **onspaces -a** command.

Example

The following example adds a 5 MB chunk of raw disk space, at an offset of 5200 kilobytes, to a dbspace named **dbspc3**:

```
EXECUTE FUNCTION task("add chunk", "dbspc3", "\\.\e:", "5120", "5200");
```

The following example adds a 10 MB mirror chunk to a blobspace named **blobsp3** with an offset of 200 kilobytes for both the primary and mirror chunks:

```
EXECUTE FUNCTION task("add chunk", "blobsp3", "/dev/raw_dev1", "10240", "200", "/dev/raw_dev2", "200");
```

Related reference:

“onspaces -a: Add a chunk to a dbspace or blobspace” on page 20-2

“onspaces -a: Add a chunk to an sbspace” on page 20-3

add log argument: Add a new logical log (SQL administration API)

Use the **add log** argument with the **admin()** or **task()** function to add a logical log to a dbspace.

Syntax

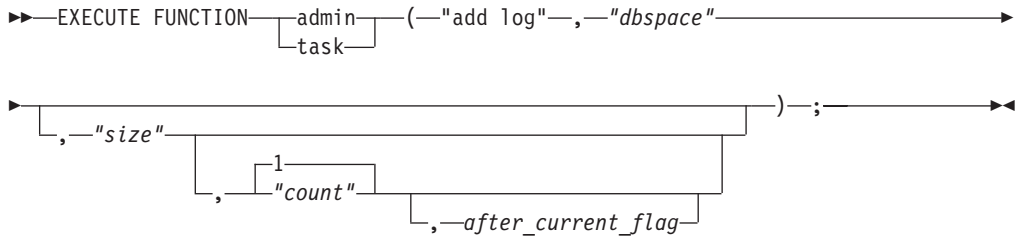

Element	Description	Key Considerations
<i>after_current_flag</i>	Whether to add the new log after the current log or after the last logical log (default).	Possible values are: <ul style="list-style-type: none">• 1 = Add the new log after the current log.• 0 = Add the new log after the last log.
<i>count</i>	The number of log files to create. The default is 1.	The number must not cause the total number of logical-log files to exceed 32,767.
<i>dbspace</i>	The name of the dbspace in which to insert a logical-log file.	You can add a log file to a dbspace only if the database server has adequate contiguous space. You can add a log file during a backup. You cannot add a log file to a blobspace or sbspace.
<i>size</i>	The size in kilobytes of the new logical-log file. The default is the size specified by the LOGSIZE configuration parameter.	This value must be an unsigned integer greater than or equal to 200 KB. Also see “admin() and task() Argument Size Specifications” on page 22-2.

Usage

The newly added log files have a status of **A** and are immediately available for use. Use **onstat -l** to view the status of your logical-log files. It is recommended that you take a level-0 backup of the root dbspace and the dbspace that contains the log file as soon as possible after running this function.

By default, the new log file is added after the last logical log. Include 1 as the fifth argument to insert the logical-log file after the current log file.

This function resembles the **onparams -a -d** command, which can add a single logical-log file. You can add multiple logical-log files to the specified db space, however, with a single invocation of this function.

Example

The command in the following example adds three logical logs after the current log, each with a size of 5 MB:

```
EXECUTE FUNCTION task ("add log", "logdbs", "5M", 3, 1);
```

Related reference:

“onparams -a -d *dbspace*: Add a logical-log file” on page 17-2

add memory argument: Increase shared memory (SQL administration API)

Use the **add memory** argument with the **admin()** or **task()** function to add to the virtual portion of shared memory.

Syntax

```
▶▶ EXECUTE FUNCTION admin  
task ("add memory", "size");
```

Element	Description	Key Considerations
<i>size</i>	The size, in kilobytes, of the new virtual shared-memory segment.	This value must not exceed the operating system limit for the size of shared-memory segments. Also see “admin() and task() Argument Size Specifications” on page 22-2.

Usage

This size defaults to the SHMADD configuration parameter.

This function is equivalent to the **onmode -a** command.

Example

The following example adds 500 KB of virtual shared-memory:

```
EXECUTE FUNCTION task("add memory", "500");
```

Related reference:

“onmode -a: Add a shared-memory segment” on page 15-2

add mirror argument: Add a mirror chunk (SQL administration API)

Use the **add mirror** argument with the **admin()** or **task()** function to add a mirror chunk to a dbspace.

Syntax

```
►► EXECUTE FUNCTION admin task ("add mirror",—"spacename"—,—"path"—,—"offset"—,—"mirror_path"—,—"mirror_offset"—);
```

Element	Description	Key Considerations
<i>mirror_path</i>	The disk partition or unbuffered device of the initial chunk of the dbspace, blobspace, or sbspace that performs the mirroring.	
<i>mirror_offset</i>	The offset to reach the mirrored chunk of the newly mirrored dbspace, blobspace, or sbspace.	See “admin() and task() Argument Size Specifications” on page 22-2.
<i>offset</i>	The offset into the disk partition or into the unbuffered device in kilobytes to reach the initial chunk of the newly mirrored dbspace, blobspace, or sbspace.	See “admin() and task() Argument Size Specifications” on page 22-2.
<i>path</i>	The disk partition or unbuffered device of the initial chunk of the dbspace, blobspace, or sbspace that you want to mirror.	
<i>spacename</i>	The name of a dbspace, blobspace, or sbspace to mirror.	

Usage

This function is equivalent to the **onspaces -m** command.

Example

The following example adds a mirror chunk to a blobspace named **blobsp3**:

```
EXECUTE FUNCTION task("add mirror","blobsp3","/dev/raw_dev1",  
"10240","/dev/raw_dev2","200");
```

Related reference:

“onspaces -m: Start mirroring” on page 20-22

alter chunk argument: Change chunk status to online or offline (SQL administration API)

Use the **alter chunk** argument with the **admin()** or **task()** function to bring a chunk online or take a chunk offline in a dbspace, blobspace, or sbspace.

Syntax

```
►► EXECUTE FUNCTION admin | task ( "alter chunk offline" | "alter chunk online" )  
►► ,—"space_name"—,—"path"—,—"offset"—) ;
```

Element	Description	Key Considerations
<i>space_name</i>	The name of the blobspace, dbspace, or sbspace.	
<i>path</i>	The disk partition or unbuffered device of the chunk.	
<i>offset</i>	The offset (in kilobytes) into the disk partition or unbuffered device to reach the chunk. The default is 0.	See “admin() and task() Argument Size Specifications” on page 22-2.

Usage

The chunk must be in a mirrored pair, or a non-primary chunk within a noncritical dbspace.

Use the **alter chunk online** argument to change the chunk status to online.

Use the **alter chunk offline** argument to change the chunk status to offline.

This function is equivalent to the **onspaces -s** command.

Example

The following example brings a chunk in a space named `dbspace4` online:

```
EXECUTE FUNCTION task("alter chunk online","dbspace4","/dev/raw_dev1","0");
```

Related reference:

“onspaces -s: Change status of a mirrored chunk” on page 20-26

alter logmode argument: Change the database logging mode (SQL administration API)

Use the **alter logmode** argument with the **admin()** or **task()** function to change the database logging mode to ANSI, buffered, non-logging, or unbuffered.

Syntax

```
▶▶ EXECUTE FUNCTION admin | task (—"alter logmode"—,—"database"—, "a" | "b" | "n" | "u")  
▶▶ )—;
```

Element	Description	Key Considerations
<i>database</i>	The name of the database with the logging mode that you want to alter.	

Usage

Unlike when you change the database logging mode with the **ondblog** or **ontape** utilities, when you use this function, the database remains accessible, and no level-0 backup is required. Ensure that no other session is active before running this function or it will fail.

Use the **"a"** argument to change the database logging to be ANSI compliant. After you create or convert a database to ANSI mode, you cannot change it back to any of the other logging modes.

Use the **"b"** argument to change the database logging to be buffered, so that transaction information is written to a buffer before it is written to a logical log.

Use the **"n"** argument to change the database logging to be non-logging, so that no database transactions are logged.

Use the **"u"** argument to change the database logging to be unbuffered, so that data is not written to a buffer before it is written to a logical log.

Example

The following example changes the logging mode of a database named **employee** to unbuffered logging:

```
EXECUTE FUNCTION task("alter logmode","employee","u");
```

Related concepts:

Chapter 14, "The onlog Utility," on page 14-1

alter plog argument: Change the physical log (SQL administration API)

Use the **alter plog** argument with the **admin()** or **task()** function to change the location and size of the physical log.

Syntax

```
►► EXECUTE FUNCTION admin task ("alter plog", dbspace size);
```

Element	Description	Key Considerations
<i>dbspace</i>	The location of the physical log.	The space allocated for the physical log must be contiguous.
<i>size</i>	The size, specified in kilobytes, of the physical log.	See "admin() and task() Argument Size Specifications" on page 22-2.

Usage

To change only the size, specify the current dbspace of the physical log.

This function is equivalent to the **onparams -p** command.

Example

The following example moves the physical log to a dbspace called **phsdb**s:

```
EXECUTE FUNCTION task ("alter plog", "phsdb", "49 M");
```

Related reference:

"**onparams -p**: Change physical-log parameters" on page 17-3

archive fake argument: Perform an unrecorded backup (SQL administration API)

Use the **archive fake** argument with the **admin()** or **task()** function to perform a backup operation to clone the data in a server without creating a persistent backup that could be used to perform a restore.

Syntax

```
►► EXECUTE FUNCTION admin task ("archive fake");
```

Usage

Use this function to populate the secondary server in a High-Availability Data Replication pair.

This function is equivalent to running the **ontape** command with the **-F** option.

Example

The following example starts an unrecorded backup:

```
EXECUTE FUNCTION task("archive fake");
```

cdr argument: Administer Enterprise Replication (SQL administration API)

Use the **cdr** argument with the **admin()** or **task()** function to administer Enterprise Replication.

Syntax

```

▶▶ EXECUTE FUNCTION admin | task ( ('cdr' command_name '
                                     (1)
                                     ' option ' ) ) ;

```

Notes:

- 1 Maximum of six option arguments.

Element	Description	Key Considerations
<i>command_name</i>	The name of a cdr command.	You cannot include any hyphens, flags, or other constraining options to <i>command_name</i> that the cdr command-line utility requires. You cannot use abbreviations.
<i>option</i>	One or more elements of the cdr command-line options to the <i>command_name</i> .	The elements must be delimited by quotation marks. Also, include (in the correct order) any hyphens, flags, or other elements of cdr command-line options that the <i>command_name</i> requires. You can use abbreviations.

Usage

Use these functions to produce the same effect as with the **cdr** command-line utility to manage Enterprise Replication.

The SQL administration API supports **cdr** commands used to administer Enterprise Replication. The following commands for monitoring Enterprise Replication are not supported:

- **cdr list grid**
- **cdr list replicate**
- **cdr list replicateset**
- **cdr list server**
- **cdr list template**
- **cdr stats recv**
- **cdr stats rqm**
- **cdr -V**
- **cdr view**

The first argument must include only the **cdr** command names exactly as specified in the appendix for the **cdr** utility in the *IBM Informix Enterprise Replication Guide*, such as **cdr define server**. Command names are case-sensitive and abbreviations (such as **cdr sto replset** instead of **cdr stop replicateset**) are **not** supported. The SQL administration API does not perform any validation before passing the parameters to the **cdr** utility.

The second and any following arguments include the command options. The options can be specified in one or up to six arguments.

The following example illustrates the use of the SQL administration API to define an Enterprise Replication server:

```
EXECUTE FUNCTION task ( 'cdr define server', '--connect=g_amsterdam
--ats=/local0/er/ats --ris=/local0/er/ris --init g_amsterdam' );
```

The following example shows how the options can be spread over several arguments; the above statement can also be written as:

```
EXECUTE FUNCTION task( 'cdr define server',
'--connect=g_amsterdam',
'--ats=/local0/er/ats',
'--ris=/local0/er/ris',
'--init g_amsterdam' );
```

The following example shows double quoted strings within an argument:

```
EXECUTE FUNCTION task('cdr change replicate',
'-d repl_1 -"db1@server1:antonio.table1" "db2@server2:carlo.table2"');
```

check data argument: Check data consistency (SQL administration API)

Use the **check data** argument with the **admin()** or **task()** function to check all pages in the specified partition for consistency, excluding blobpages and sbpages.

Syntax

```
►► EXECUTE FUNCTION admin (task ("check data"—,"partition_number"—); ◀◀
```

Element	Description	Key Considerations
<i>partition_number</i>	The partition number in which to check the data.	Find the partition numbers in the partnum column of the systables system catalog table.

Usage

Run this function to check entries in the bitmap page against the pages to verify mapping.

This function is equivalent to the **oncheck -cd** command.

Example

The following example checks the consistency of all pages in the partition with a number of 1048611:

```
EXECUTE FUNCTION task("check data","1048611");
```

Related reference:

“**oncheck -cd** and **oncheck -cD** commands: Check pages” on page 9-8

check extents argument: Check extent consistency (SQL administration API)

Use the **check extents** argument with the **admin()** or **task()** function to verify that the extents on disk correspond to the current control information.

Syntax

```
▶▶ EXECUTE FUNCTION admin
task
▶▶ ("check extents" , ,dbspace_number) ;
```

Element	Description	Key Considerations
<i>dbspace_number</i>	The number of the dbspace to check.	

Usage

Run this function to check each chunk-free list and corresponding free space and each tblspace extent. If you do not specify a dbspace number, all dbspaces are checked. The function checks dbspaces, blobspaces, smart-large-object extents, and user-data and metadata information in sbspace chunks.

This function is equivalent to the **oncheck -ce** command.

Example

The following example checks the extents in the dbspace with the number 2:

```
EXECUTE FUNCTION task("check extents",2);
```

Related reference:

“**oncheck -ce, -pe**: Check the chunk-free list” on page 9-10

check partition argument: Check partition consistency (SQL administration API)

Use the **check partition** argument with the **admin()** or **task()** function to print tblspace information for a table or fragment.

Syntax

```
▶▶ EXECUTE FUNCTION admin
task
```

► (—"check partition"—,—"partition_number"—);

Element	Description	Key Considerations
<i>partition_number</i>	The number of the partition that you want to check for consistency.	Find the partition numbers in the partnum column of the systables system catalog table.

Usage

The **check partition** argument with the **task()** function returns information that is equivalent to output of the **oncheck -pt** command. The output contains general information such as the maximum row size, the number of keys, the number and size of extents, the pages allocated and used per extent, the current serial value, and the date that the table was created.

The **admin()** function returns an integer that you can use to find information in the **command_history** table in the **sysadmin** database.

Example

The following example prints information for partition 1048611:

```
EXECUTE FUNCTION task("check partition","1048611");
```

Related reference:

“oncheck -pt and -pT: Display tblspaces for a Table or Fragment” on page 9-19

checkpoint argument: Force a checkpoint (SQL administration API)

Use the **checkpoint** argument with the **admin()** or **task()** function to force a checkpoint.

Syntax

```
► EXECUTE FUNCTION admin task ("checkpoint"—, "hard"  
"block"  
"norm"  
"unlock")—;
```

Usage

This function forces a checkpoint that flushes the buffers to disk. You can use this function to force a checkpoint if the most recent checkpoint record in the logical log was preventing the logical-log file from being freed (status U-B-L).

Use the **block** argument to prevent the database server from processing any transactions. Use this option to perform an external backup on Informix. While the database server is blocked, users cannot access it, except in read-only mode. No transactions can complete until the database server is unblocked.

Use the **hard** argument to force a blocking checkpoint. This is the default.

Use the **norm** argument to force a nonblocking checkpoint.

Use the **unlock** argument to unblock the database server. When the database server is unblocked, data transactions and normal database server operations can resume. Use this option after you complete an external backup on Informix.

This function is equivalent to the **onmode -c** command.

Example

The following example starts a blocking checkpoint:

```
EXECUTE FUNCTION task("checkpoint","block");
```

Related reference:

“onmode -c: Force a checkpoint” on page 15-4

clean sbspace argument: Release unreferenced smart large objects (SQL administration API)

Use the **clean sbspace** argument with the **admin()** or **task()** function to release any unreferenced BLOB or CLOB objects from the sbspace.

Syntax

```
▶▶ EXECUTE FUNCTION admin (task ("clean sbspace", "sbspace")); ▶▶
```

Element	Description	Key Considerations
<i>sbspace</i>	The name of the sbspace to clean.	

Usage

This function is equivalent to the **onspaces -cl** command.

Example

The following example cleans an sbspace named **sbsp1**:

```
EXECUTE FUNCTION task("clean sbspace","sbsp1");
```

Related reference:

“onspaces -cl: Clean up stray smart large objects in sbspaces” on page 20-18

create blobspace argument: Create a blobspace (SQL administration API)

Use the **create blobspace** argument with the **admin()** or **task()** function to create a blobspace.

Syntax

```
▶▶ EXECUTE FUNCTION admin ( task ( ) ▶▶
```

Related reference:

“onspaces -c -b: Create a blobspace” on page 20-5

“Avoid overwriting a chunk” on page 20-28

create blobspace from storagepool argument: Create a blobspace from the storage pool (SQL administration API)

Use the **create blobspace from storagepool** argument with the **admin()** or **task()** function to create a blobspace from an entry from the storage pool.

Syntax

```
▶ EXECUTE FUNCTION admin | task ("create blobspace from storagepool" |   
▶, "space_name", "size", blobpage_size | mirroring_flag) ; ▶
```

Element	Description	Key Considerations
<i>space_name</i>	The name of the blobspace.	The blobspace name must be unique and cannot exceed 128 bytes. It must begin with a letter or underscore and must contain only letters, numbers, underscores, or the \$ character.
<i>size</i>	The size, in kilobytes, of the initial chunk of the new blobspace.	See “admin() and task() Argument Size Specifications” on page 22-2.
<i>blobpage_size</i>	The blobpage size, specified in terms of <i>page_unit</i> , the number of disk pages per blobpage	The page size is optional. However if you specify 1 for mirroring, you must also specify a page size.
<i>mirroring_flag</i>	Either: 1 = mirroring 0 = no mirroring	The mirroring flag is optional.

Examples

The following command creates a mirrored blobspace named blobspace1. The new blobspace has a size of 100 gigabytes and a blobpage size of 100 pages.

```
EXECUTE FUNCTION task("create blobspace from storagepool", "blobspace1", "100 GB", "100", "1");
```

The following command creates an unmirrored blobspace named blobspace2 with the default blobpage size, so a blobpage size is not specified:

```
EXECUTE FUNCTION task("create blobspace from storagepool", "blobspace2", "5000");
```

create chunk argument: Create a chunk (SQL administration API)

Use the **create chunk** argument with the **admin()** or **task()** function to create a chunk in a dbspace or in a blobspace.

Syntax

```

▶ EXECUTE FUNCTION {admin | task} (
▶ "create {with_check} chunk", "spacename", "pathname"
▶ , "size"
▶ , "offset"
▶ , "mirror_path"
▶ , "mirror_offset"
▶ );
  
```

Element	Description	Key Considerations
<i>mirror_path</i>	The path to the mirror chunk. If you are adding a chunk to a mirrored storage space, you must also add a mirror chunk.	
<i>mirror_offset</i>	The location of the mirror chunk.	
<i>offset</i>	The location of the new chunk.	
<i>pathname</i>	The path of the added disk space.	
<i>size</i>	The amount of disk space to add in kilobytes.	See "admin() and task() Argument Size Specifications" on page 22-2.
<i>spacename</i>	The name of the dbspace, blobspace, or sbspace to which you are adding disk space.	

Usage

Use the **create with_check chunk** argument to check the specified path name and return an error if it does not exist.

This function is equivalent to the **onspaces -a** command.

Example

The following example adds a 5 MB chunk of raw disk space, at an offset of 5200 kilobytes, to a dbspace named **dbspc3**:

```
EXECUTE FUNCTION task("create chunk", "dbspc3", "\\.\e:", "5120", "5200");
```

The following example adds a 10 MB mirror chunk to a blobspace named **blobsp3** with an offset of 200 kilobytes for both the primary and mirror chunks:

```
EXECUTE FUNCTION task("create with_check chunk","blobsp3","/dev/raw_dev1","10240",
"200","/dev/raw_dev2","200");
```

Related reference:

“onspaces -a: Add a chunk to a dbspace or blobspace” on page 20-2

“Avoid overwriting a chunk” on page 20-28

“onspaces -a: Add a chunk to an sbospace” on page 20-3

create chunk from storagepool argument: Create a chunk from the storage pool (SQL administration API)

Use the **create chunk from storagepool** argument with the **admin()** or **task()** function to manually create a chunk from an entry in the storage pool.

Syntax

```
▶▶ EXECUTE FUNCTION admin task ("create chunk from storagepool"
▶▶,—"space_name"—,—"size"—);
```

Element	Description	Key Considerations
<i>space_name</i>	The name of the storage space to which you are adding the chunk.	
<i>size</i>	The size, in kilobytes, of the initial chunk.	See “admin() and task() Argument Size Specifications” on page 22-2.

Usage

You can also use an SQL administration API command with the **modify space expand** argument to manually create a chunk from the storage pool and add the chunk to the specified storage space. However, if the space has extendable chunks, Informix might extend a chunk instead of creating a new one. Unlike the **modify space expand** argument, the **create chunk from storagepool** argument forces Informix to add a chunk.

Example

The following command adds a chunk to the dbspace named logdbs. The new chunk has a size of 200 megabytes.

```
EXECUTE FUNCTION task("create chunk from storagepool", "logdbs", "200 MB");
```

Related reference:

“modify space expand argument: Expand the size of a space (SQL administration API)” on page 22-69

create database argument: Create a database (SQL administration API)

Use the **create database** argument with the **admin()** or **task()** function to create a database.

Syntax

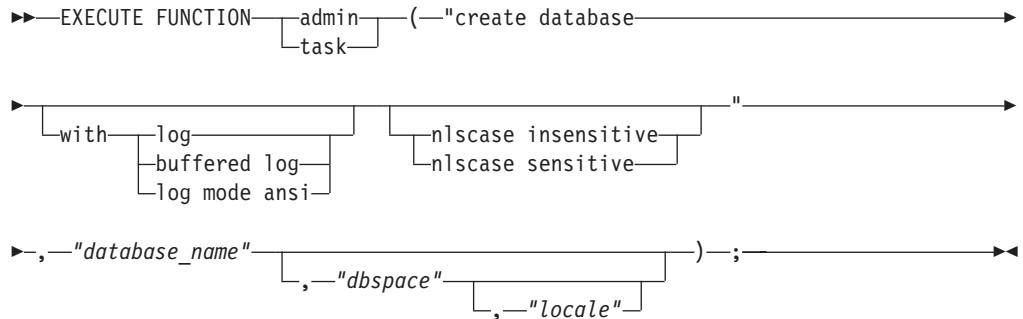

Element	Description	Key Considerations
<i>database_name</i>	The name of the database.	
<i>dbspace</i>	The name of the dbspace to store the data for this database. The default is the root dbspace.	The dbspace must already exist on the database server.
<i>locale</i>	The locale associated with the database.	

Usage

This function is equivalent to the CREATE DATABASE statement.

Examples

The following example creates the database named demodbs with unbuffered logging:

```
EXECUTE FUNCTION task("create database with log","demodbs");
```

The following example creates a database that is not case-sensitive named demodbs2 with ANSI compliant logging in the dbspace named dataspace1:

```
EXECUTE FUNCTION task("create database with log mode ansi nlscape insensitive",
"demodbs2","dataspace1");
```

The following example creates a database named demodbs3 with a French-Canadian locale in the dbspace name dataspace1:

```
EXECUTE FUNCTION TASK ("create database","demodbs3","dataspace1","fr_ca.8859-1");
```

Related reference:

 CREATE DATABASE statement (SQL Syntax)

create dbspace argument: Create a dbspace (SQL administration API)

Use the **create dbspace** argument with the **admin()** or **task()** function to create a dbspace.

Syntax

```
EXECUTE FUNCTION admin | task (—"create" with_check "dbspace"—,—"dbspace"—,—"pathname"—  
—"size"—,—"offset"—,—"pagesize"—,—"first_extsize"—,—"next_extsize"—);
```

Element	Description	Key Considerations
<i>dbspace</i>	The name of the dbspace to be created.	
<i>first_extsize</i>	The size, in kilobytes, of the first extent for the tblspace .	See "admin() and task() Argument Size Specifications" on page 22-2.
<i>next_extsize</i>	The size, in kilobytes, of the next extents in the tblspace .	See "admin() and task() Argument Size Specifications" on page 22-2.
<i>offset</i>	The offset, in kilobytes, into the disk partition or into the device to reach the initial chunk of the new dbspace.	
<i>pagesize</i>	The non-default page size, in kilobytes, for the new dbspace.	See "admin() and task() Argument Size Specifications" on page 22-2.
<i>pathname</i>	The disk partition or device of the initial chunk of the dbspace that you are creating.	Valid page sizes depend on the default page size for the computer: <ul style="list-style-type: none">• 2 KB default page size: 2, 4, 6, 8, 10, 12, or 16 KB• 4 KB default page size: 4, 8, 12, or 16 KB
<i>size</i>	The size, in kilobytes, of the initial chunk of the new dbspace. The size is rounded to a multiple of the page size.	See "admin() and task() Argument Size Specifications" on page 22-2.

Usage

Use the **create with_check dbspace** argument to check the specified path name and return an error if it does not exist.

This function is equivalent to the **onspaces -c -d** command.

Example

The following example creates a dbspace that has a size of 20 MB with an offset of 0.

```
EXECUTE FUNCTION task ("create dbspace", "dbspace3",
"$INFORMIXDIR/WORK/dbspace3", "20 M", "0");
```

Related reference:

“onspaces -c -d: Create a dbspace” on page 20-7

“Avoid overwriting a chunk” on page 20-28

create dbspace from storagepool argument: Create a dbspace from the storage pool (SQL administration API)

Use the **create dbspace from storagepool** argument with the **admin()** or **task()** function to create a permanent dbspace from an entry in the storage pool.

Syntax

```
EXECUTE FUNCTION admin | task "create dbspace from storagepool"
, "dbspace" , "chunk_size" ,
, "page_size" , "mirroring_flag" , "first_extsize" , "next_extsize" ) ;
```

Element	Description	Key Considerations
<i>chunk_size</i>	Size of the initial chunk of the new dbspace.	See “admin() and task() Argument Size Specifications” on page 22-2.
<i>dbspace</i>	Name of the dbspace to be created.	Must be unique among dbspace names, and cannot exceed 128 bytes. It must begin with a letter or underscore, and can include only letters, digits, underscore (<code>_</code>) symbols, or the \$ character.
<i>first_extent</i>	Size, in kilobytes, of the first extent for the tblspace tblspace .	See “admin() and task() Argument Size Specifications” on page 22-2.
<i>mirroring_flag</i>	Either: 1 = mirroring 0 = no mirroring	The mirroring flag is optional. If none is specified, the default is an unmirrored dbspace.
<i>next_extent</i>	Size, in kilobytes, of the next extents in the tblspace tblspace	See “admin() and task() Argument Size Specifications” on page 22-2.

Element	Description	Key Considerations
<i>page_size</i>	Nondefault page size, in kilobytes, for the new dbspace.	The page size is optional. If you specify 1 for mirroring, however, you must also specify a page size. Valid page sizes depend on the default page size for the computer: <ul style="list-style-type: none"> • 2 KiB default page size: 2, 4, 6, 8, 10, 12, or 16 KiB • 4 KiB default page size: 4, 8, 12, or 16 KiB

For the **admin()** or **task()** syntax for creating a temporary dbspace, see “create tempdbspace argument: Create a temporary dbspace (SQL administration API)” on page 22-38.

Examples

The following command creates a mirrored dbspace named `dbspace3`. The new dbspace has a size of 1 gigabyte, a page size of 6 kilobytes, a **tblspace** first extent size of 200 kilobytes, and a next extent size of 400 kilobytes.

```
EXECUTE FUNCTION task("create dbspace from storagepool",
  "dbspace3", "1 GB", "6", "1", "200", "400");
```

The following command creates an unmirrored dbspace named `dbspace8`. The size of the new dbspace is 50 megabytes. Because no page size is specified, the new dbspace has the default page size.

```
EXECUTE FUNCTION task("create dbspace from storagepool",
  "dbspace8", "50000");
```

create sbspace argument: Create an sbspace (SQL administration API)

Use the **create sbspace** argument with the **admin()** or **task()** function to create an sbspace.

Syntax

```

▶▶ EXECUTE FUNCTION admin | task (
▶ "create with_check sbspace" —, —"sbspace" —, —"pathname" —
▶ , —"size" — , —"offset" —
▶ ) —;

```

Element	Description	Key Considerations
<i>offset</i>	The offset, in kilobytes, into the disk partition or into the device to reach the initial chunk of the new sbspace.	

Element	Description	Key Considerations
<i>pathname</i>	The disk partition or unbuffered device of the initial chunk of the sbspace.	
<i>sbspace</i>	The name of the sbspace to be created.	
<i>size</i>	The size, in kilobytes, of the initial chunk of the new sbspace.	See “admin() and task() Argument Size Specifications” on page 22-2.

Usage

Use the **create with_check sbspace** argument to check the specified path name and return an error if it does not exist.

This function is equivalent to the **onspaces -c -S** command.

Example

The following example creates a new sbspace that has a size of 20 MB with an offset of 0:

```
EXECUTE FUNCTION task ("create sbspace","sbspace2",
"$INFORMIXDIR/WORK/sbspace2","20 M","0");
```

Related reference:

“onspaces -c -S: Create an sbspace” on page 20-11

“Avoid overwriting a chunk” on page 20-28

“create tempsbspace argument: Create a temporary sbspace (SQL administration API)” on page 22-40

create sbspace from storagepool argument: Create an sbspace from the storage pool (SQL administration API)

Use the **create sbspace from storagepool** argument with the **admin()** or **task()** function to create an sbspace from an entry from the storage pool.

Syntax

```
▶▶ EXECUTE FUNCTION admin task ("—create sbspace from storagepool—")
▶,— "space_name"—,— "size"— ,— "logging_flag"— ,— "mirroring_flag"— )—;▶▶
```

Element	Description	Key Considerations
<i>space_name</i>	The name of the sbspace.	The sbspace name must be unique and cannot exceed 128 bytes. It must begin with a letter or underscore and must contain only letters, numbers, underscores, or the \$ character.

Element	Description	Key Considerations
<i>size</i>	The size, in kilobytes, of the initial chunk of the new sbspace.	See "admin() and task() Argument Size Specifications" on page 22-2.
<i>logging_flag</i>	Either: 1 = logging 0 = no logging	The logging flag is optional. However if you specify 1 for mirroring, you must also specify a logging flag.
<i>mirroring_flag</i>	Either: 1 = mirroring 0 = no mirroring	The mirroring flag is optional.

Examples

The following command creates a mirrored and logged sbspace named sbspace1. The new sbspace has a size of 240 megabytes.

```
EXECUTE FUNCTION task("create sbspace from storagepool", "sbspace1",
"240 MB", "1", "1");
```

The following command creates an unmirrored and unlogged sbspace named sbspace2. This sbspace has a size of 5 gigabytes.

```
EXECUTE FUNCTION task("create sbspace from storagepool", "sbspace2", "5 GB");
```

create sbspace with accesstime argument: Create an sbspace that tracks access time (SQL administration API)

Use the **create sbspace with accesstime** argument with the **admin()** or **task()** function to create an sbspace that tracks the time of access for all smart large objects stored in the sbspace.

Syntax

```

▶ EXECUTE FUNCTION admin ( _____ )
task
▶ "create with_check sbspace with accesstime" —, —"sbspace" —, —"pathname" —
▶ _____ ) ;
, —"size" , —"offset"

```

Element	Description	Key Considerations
<i>offset</i>	The offset, in kilobytes, into the disk partition or into the device to reach the initial chunk of the new sbspace.	
<i>pathname</i>	The disk partition or unbuffered device of the initial chunk of the sbspace.	
<i>sbspace</i>	The name of the sbspace to be created.	

Element	Description	Key Considerations
<i>size</i>	The size, in kilobytes, of the initial chunk of the new sbspace.	See “admin() and task() Argument Size Specifications” on page 22-2.

Usage

Use the **create with_check sbspace** argument to check the specified path name and return an error if it does not exist.

This function is equivalent to the **onspaces -c -S** command for creating an sbspace and using the **set sbspace accesstime** argument with the **admin()** or **task()** function to start tracking the time of access for all smart large objects stored in the sbspace.

Example

The following example creates a new sbspace that tracks access time. This sbspace has a size of 20 MB with an offset of 0:

```
EXECUTE FUNCTION task ("create sbspace with accesstime","sbspace4",
"$INFORMIXDIR/WORK/sbspace4","20 M","0");
```

Related reference:

“set sbspace accesstime argument: Control access time tracking (SQL administration API)” on page 22-110

create sbspace with log argument: Create an sbspace with transaction logging (SQL administration API)

Use the **create sbspace with log** argument with the **admin()** or **task()** function to create an sbspace with transaction logging turned on.

Syntax

```

▶▶ EXECUTE FUNCTION admin ( task )
▶ "create with_check sbspace with log" —,—"sbspace"—,—"pathname"—
▶ (,—"size"— ,—"offset" ) ;

```

Element	Description	Key Considerations
<i>offset</i>	The offset, in kilobytes, into the disk partition or into the device to reach the initial chunk of the new sbspace.	
<i>pathname</i>	The disk partition or unbuffered device of the initial chunk of the sbspace.	
<i>sbspace</i>	The name of the sbspace to be created.	

Element	Description	Key Considerations
<i>size</i>	The size, in kilobytes, of the initial chunk of the new sbspace.	See “admin() and task() Argument Size Specifications” on page 22-2.

Usage

Use the **create with_check sbspace** argument to check the specified path name and return an error if it does not exist.

This function is equivalent to the **onspaces -c -S** command to create an sbspace with the option for turning logging on.

Example

The following example creates a new sbspace with transaction logging turned on. This sbspace has a size of 20 MB with an offset of 0:

```
EXECUTE FUNCTION task ("create sbspace with log","sbspace2",
"$INFORMIXDIR/WORK/sbspace2","20 M","0");
```

Related reference:

“onspaces -c -S: Create an sbspace” on page 20-11

[📄 Sbspace logging \(Administrator's Guide\)](#)

create tempdbspace argument: Create a temporary dbspace (SQL administration API)

Use the **create tempdbspace** argument with the **admin()** or **task()** function to create a temporary dbspace.

Syntax

```

▶ EXECUTE FUNCTION admin | task (
▶ "create with_check tempdbspace" , ,"temp" , ,"pathname"
▶ , ,"chunk" , ,"offset" , ,"page" , ,"first" , ,"next"
▶ ) ;

```

Element	Description	Key Considerations
<i>chunk</i>	Size, in kilobytes, of the initial chunk of the new temporary dbspace.	See “admin() and task() Argument Size Specifications” on page 22-2.
<i>first</i>	Size, in kilobytes, of the first extent for the tblspace tblspace .	See “admin() and task() Argument Size Specifications” on page 22-2.
<i>next</i>	Size, in kilobytes, of the next extents in the tblspace tblspace .	See “admin() and task() Argument Size Specifications” on page 22-2.

Element	Description	Key Considerations
<i>offset</i>	Offset, in kilobytes, into the disk partition or into the device to reach the initial chunk of the new temporary dbspace.	See “admin() and task() Argument Size Specifications” on page 22-2
<i>page</i>	Non-default page size, in kilobytes, for the new temporary dbspace.	Valid page sizes depend on the default page size for the computer: <ul style="list-style-type: none"> • 2 KiB default page size: 2, 4, 6, 8, 10, 12, or 16 KiB • 4 KiB default page size: 4, 8, 12, or 16 KiB
<i>pathname</i>	Path to the disk partition or device of the initial chunk of the temporary dbspace that you are creating.	
<i>temp</i>	Name of the temporary dbspace to be created.	Cannot exceed 128 bytes. It must begin with a letter or underscore, and can include only letters, digits, underscore (<code>_</code>) symbols, or the <code>\$</code> character.

Usage

Use the **create with_check tempdbspace** argument to check the specified path name and return an error if the path does not exist.

This function is equivalent to the **onspaces -c -d -t** command.

Example

The following example creates a temporary dbspace that has a size of 20 MiB with an offset of 0:

```
EXECUTE FUNCTION task("create tempdbspace","tempdbspace3",
"$INFORMIXDIR/WORK/tempdbspace3","20 M","0");
```

For the **admin()** or **task()** syntax to create a permanent dbspace from the storage pool, see “create dbspace from storagepool argument: Create a dbspace from the storage pool (SQL administration API)” on page 22-33.

Related reference:

“onspaces -c -d: Create a dbspace” on page 20-7

create tempdbspace from storagepool argument: Create a temporary dbspace from the storage pool (SQL administration API)

Use the **create tempdbspace from storagepool** argument with the **admin()** or **task()** function to create a temporary dbspace from an entry from the storage pool.

Syntax

```

EXECUTE FUNCTION admin (task) ("create tempdbspace from storagepool"
, "space_name" , "size" , "page_size") ;

```

Element	Description	Key Considerations
<i>space_name</i>	The name of the temporary dbspace.	
<i>size</i>	The size, in kilobytes, of the initial chunk of the new temporary dbspace.	See "admin() and task() Argument Size Specifications" on page 22-2.
<i>page_size</i>	The non-default page size, in kilobytes, for the new temporary dbspace.	The page size is optional.

Example

The following command creates a temporary dbspace named tempdbspace1. The new dbspace has a size of 1 gigabyte and a page size of 12 kilobytes.

```

EXECUTE FUNCTION task("create tempdbspace from storagepool", "tempdbspace1",
"1 GB", "12");

```

create tempsbspace argument: Create a temporary sbpace (SQL administration API)

Use the **create sbpace** argument with the **admin()** or **task()** function to create an sbpace.

Syntax

```

EXECUTE FUNCTION admin (task) (
"create with_check tempsbpace" , "sbspace" , "pathname"
, "size" , "offset") ;

```

Element	Description	Key Considerations
<i>offset</i>	The offset, in kilobytes, into the disk partition or into the device to reach the initial chunk of the new temporary sbpace.	
<i>pathname</i>	The disk partition or unbuffered device of the initial chunk of the temporary sbpace.	
<i>sbspace</i>	The name of the temporary sbpace to be created.	

Usage

Use the defragment argument to defragment specific tables. Use the defragment partnum argument to defragment one or more specific disk partitions.

Information about defragmentation is stored in shared memory. Use the **oncheck -pt and pT** command to display information about the number of extents for a specific table or fragment. Use the **onstat -g defragment** command to display information about active defragment requests. See the *IBM Informix Administrator's Reference* for more information about the **oncheck -pt and pT** and **onstat -g defragment** commands.

If the defragment request reduces the number of extents by at least 1 extent, the request returns 0 (success), even if there are many extents in the partition.

If a partition has a single extent, the defragment request returns 0 to indicate that the request was a success, even though no extents were merged.

Examples

To defragment the customer table in the stores_demo database, use either of the following functions:

```
EXECUTE FUNCTION task("defragment","stores_demo:informix.customer");
EXECUTE FUNCTION admin("defragment","stores_demo:informix.customer");
```

To defragment an index, you must specify the partition number for the index, as in these two function examples:

```
EXECUTE FUNCTION task("defragment partnum","2097154");
EXECUTE FUNCTION admin("defragment partnum","2097154");
```

To defragment a list of partitions, use either of the following functions:

```
EXECUTE FUNCTION task("defragment partnum", "16777217,28477346");
EXECUTE FUNCTION admin("defragment partnum", "16777217,28477346");
```

drop blobspace argument: Drop a blobspace (SQL administration API)

Use the **drop blobspace** argument with the **admin()** or **task()** function to drop the specified blobspace.

Syntax

```
►► EXECUTE FUNCTION admin task ("drop blobspace"—,—"blobspace_name"—————►
►) —;—————►
```

Element	Description	Key Considerations
<i>blobspace_name</i>	The name of the blobspace to drop.	Must be an existing blobspace. Before you drop a blobspace, drop all tables that include a TEXT or BYTE column that references the blobspace.

Usage

This function is equivalent to the **onspaces -d** command.

Example

The following example drops the blob space named **blob space3**:

```
EXECUTE FUNCTION task("drop blob space", "blob space3");
```

Related reference:

“onspaces -d: Drop a blob space, db space, ext space, or sb space” on page 20-20

drop blob space to storage pool argument: Return space from an empty blob space to the storage pool (SQL administration API)

Use the **drop blob space to storage pool** argument with the **admin()** or **task()** function to return the space from an empty blob space to the storage pool.

Syntax

```
▶▶ EXECUTE FUNCTION admin (task) ("drop blob space to storage pool"  
▶▶ , "space_name") ;
```

Element	Description	Key Considerations
<i>space_name</i>	The name of the empty blob space.	

Example

The following command drops an empty blob space named **blob2** and adds all of the freed space to the storage pool.

```
EXECUTE FUNCTION task("drop blob space to storage pool", "blob2");
```

drop chunk argument: Drop a chunk (SQL administration API)

Use the **drop chunk** argument with the **admin()** or **task()** function to drop the specified chunk from a db space, blob space, or sb space.

Syntax

```
▶▶ EXECUTE FUNCTION admin (task) ("drop chunk"  
▶▶ , "space_name" , ,"pathname" , "offset") ;
```

Element	Description	Key Considerations
<i>offset</i>	The offset, in kilobytes, into the disk partition or into the unbuffered device to reach the initial chunk of the dbspace, blobspace, or sbspace that you are dropping.	The starting offset, an unsigned integer, must be equal to or greater than 0. The starting offset plus the chunk size cannot exceed the maximum chunk size. The maximum offset is 4 TB. Also see "admin() and task() Argument Size Specifications" on page 22-2.
<i>pathname</i>	The disk partition or unbuffered device of the initial chunk of the dbspace, blobspace, or sbspace that you are dropping.	The chunk must be an existing unbuffered device or buffered file. When you specify a path name, you can use either a full path name or a relative path name. However, if you use a relative path name, it must be relative to the directory that was the current directory when you initialized the database server.
<i>space_name</i>	The name of the dbspace, sbspace, or blobspace from which to drop a chunk.	You can drop a chunk from a dbspace, temporary dbspace, or sbspace when the database server is online or quiescent. You can drop a chunk from a blobspace only when the database server is in quiescent mode.

Usage

This function is equivalent to the **onspaces -d** command.

Example

The following example drops a chunk at an offset of 5200 kilobytes from a dbspace named **dbspc3**:

```
EXECUTE FUNCTION task("drop chunk", "dbspc3", "\\.\e:", "5200");
```

Related reference:

“onspaces -d: Drop a chunk in a dbspace, blobspace, or sbspace” on page 20-19

drop chunk to storagepool argument: Return space from an empty chunk to the storage pool (SQL administration API)

Use the **drop chunk to storagepool** argument with the **admin()** or **task()** function to return the space from an empty chunk to the storage pool.

Syntax

```
►► EXECUTE FUNCTION admin (task) ("drop chunk to storagepool"  
►►,—"space_name"—,—"path"—,—"offset"—);
```

Element	Description	Key Considerations
<i>space_name</i>	The name of the storage space in which the chunk resides.	
<i>path</i>	The path of the chunk.	
<i>offset</i>	The offset, in kilobytes, of the chunk.	

Example

The following command drops an empty chunk in a dbspace named bigdbs and adds all of the freed space to the storage pool.

```
EXECUTE FUNCTION task("drop chunk to storagepool", "bigdbs", "/dev/rawdisk23",  
"100 KB");
```

drop database argument: Drop a database (SQL administration API)

Use the **drop database** argument with the **admin()** or **task()** function to drop a database.

Syntax

```
►► EXECUTE FUNCTION admin ("drop database"—,—"database_name"—);
```

Element	Description	Key Considerations
<i>database_name</i>	The name of the database.	

Usage

This function is equivalent to the DROP DATABASE statement. This function deletes the entire database, including all of the system catalog tables, objects, and data.

Example

The following example drops the database named demodbs:

```
EXECUTE FUNCTION task("drop database","demodbs");
```

Related reference:

[DROP DATABASE statement \(SQL Syntax\)](#)

drop dbspace argument: Drop a dbspace (SQL administration API)

Use the **drop dbspace** argument with the **admin()** or **task()** function to drop the specified dbspace.

Syntax

```
►► EXECUTE FUNCTION admin task ("drop dbspace",—"dbspace_name"—);
```

Element	Description	Key Considerations
<i>dbspace_name</i>	The name of the dbspace to drop.	The dbspace must exist. Before you drop a dbspace, drop all databases and tables that you previously created in the dbspace.

Usage

This function is equivalent to the **onspaces -d** command.

Example

The following example drops the dbspace named **dbspace4**:

```
EXECUTE FUNCTION task("drop dbspace","dbspace4");
```

Related reference:

“onspaces -d: Drop a blobspace, dbspace, extspace, or sbpace” on page 20-20

drop dbspace to storagepool argument: Return space from an empty dbspace to the storage pool (SQL administration API)

Use the **drop dbspace to storagepool** argument with the **admin()** or **task()** function to return the space from an empty dbspace to the storage pool.

Syntax

```
►► EXECUTE FUNCTION admin task ("—"drop dbspace to storagepool"—  
►,—"space_name"—);
```

Element	Description	Key Considerations
<i>space_name</i>	The name of the empty dbspace.	

Example

The following command drops an empty dbspace named `db5` and adds all of the freed space to the storage pool.

```
EXECUTE FUNCTION task("drop dbspace to storagepool", "db5");
```

drop log argument: Drop a logical log (SQL administration API)

Use the **drop log** argument with the **admin()** or **task()** function to drop the specified logical log.

Syntax

```
▶▶ EXECUTE FUNCTION admin (-"drop log"-, -"log_number"-)-;▶▶
```

└─ task ─┘

Element	Description	Key Considerations
<i>log_number</i>	The logical log file number.	The number must be an unsigned integer greater than or equal to 0.

Usage

Use this function to drop a single logical log file.

The database server requires a minimum of three logical-log files at all times. You cannot drop a log file if the database server has only three logical-log files.

Important: Before you can drop any of the first three logical-log files, you must add new logical-log files and run a backup of the logical-log files. The backup must be run using either the **ontape -a** command or the **ontape -c** command. After you add the new logical-log files and run a backup, you can then use **onparams -d -llognum** to delete the first three logical-log files.

The status of the log file determines if the log file can be dropped, and the actions taken by the database server when the log file is dropped:

- If you drop a log file that has never been written to, status is newly Added (**A**), the database server deletes the log file and frees the space immediately.
- If you drop a used log file that has a status of User (**U**) or Free (**F**), the database server marks the log file as Deleted (**D**). After you take a level-0 backup of the dbspaces that contain the log files and the root dbspace, the database server deletes the log file and frees the space.
- You cannot drop a log file that is currently in use (**C**) or contains the last checkpoint record (**L**).

You can obtain the log number from the number field of the **onstat -l** command. The sequence of log numbers might be out of order.

This function is equivalent to the **onparams -d -l lognum** command.

Example

The following example drops the logical log with a file number of 2:

```
EXECUTE FUNCTION task("drop log","2");
```

The following example drops the log for a specific chunk by looking up the log number based on the chunk number:

```
SELECT task("drop log", number) FROM sysmaster:syslogfil WHERE chunk = 1;
```

Related reference:

“onparams -d -l lognum: Drop a logical-log file” on page 17-2

drop sbspace argument: Drop an sbspace (SQL administration API)

Use the **drop sbspace** argument with the **admin()** or **task()** function to drop the specified sbspace.

Syntax

```
▶▶ EXECUTE FUNCTION admin (—"drop sbspace"—,—"sbspace_name"—); ▶▶  
task
```

Element	Description	Key Considerations
<i>sbspace_name</i>	The name of the sbspace to drop.	The sbspace must exist. Before you drop an sbspace, drop all tables that include a BLOB or CLOB column that references the sbspace.

Usage

This function is equivalent to the **onspaces -d** command.

Example

The following example drops the sbspace named **sbspace3**:

```
EXECUTE FUNCTION task("drop dbspace","sbspace3");
```

Related reference:

“onspaces -d: Drop a blobspace, dbspace, extspace, or sbspace” on page 20-20

drop sbspace to storagepool argument: Return space from an empty sbspace to the storage pool (SQL administration API)

Use the **drop sbspace to storagepool** argument with the **admin()** or **task()** function to return the space from an empty sbspace to the storage pool.

Syntax

```
▶▶ EXECUTE FUNCTION admin (—,—"drop sbspace to storagepool"—) ▶▶  
task
```

▶ "space_name" —) —; —————▶▶

Element	Description	Key Considerations
<i>space_name</i>	The name of the empty sbspace.	

Example

The following command drops an empty sbspace named sbspace8 and adds all of the freed space to the storage pool.

```
EXECUTE FUNCTION task("drop sbspace to storagepool", "sbspace8");
```

drop tempdbspace argument: Drop a temporary dbspace (SQL administration API)

Use the **drop tempdbspace** argument with the **admin()** or **task()** function to drop the specified temporary dbspace.

Syntax

▶▶ EXECUTE FUNCTION admin (—"drop tempdbspace"—,—"tempdbspace_name"—▶▶
task

▶) —; —————▶▶

Element	Description	Key Considerations
<i>tempdbspace_name</i>	The name of the temporary dbspace to drop.	The temporary dbspace must exist. Before you drop a temporary dbspace, drop all databases and tables that you previously created in the temporary dbspace.

Usage

This function is equivalent to the **onspaces -d** command.

Example

The following example drops the temporary dbspace named **tdbpace2**:

```
EXECUTE FUNCTION task("drop tempdbspace", "tdbpace2");
```

Related reference:

“message log rotate argument: Rotate the message log file (SQL administration API)” on page 22-64

“message log truncate argument: Delete the contents of a message log file (SQL administration API)” on page 22-65

“message log delete argument: Delete a message log file (SQL administration API)” on page 22-64

ha make primary argument: Change the mode of a secondary server (SQL administration API)

Use the **ha make primary** argument with the **admin()** or **task()** function to change the specified secondary server to a primary or standard server.

Syntax

```
► EXECUTE FUNCTION {admin|task} ( ("ha make primary" | "ha make primary force" | "dbserver") ) ;
```

Element	Description	Key Considerations
<i>dbserver</i>	The name of the database server.	The name must be defined in the DBSERVERNAME or DBSERVERALIASES configuration parameter, or as an Enterprise Replication group name.

Usage

This function has different results depending on the type of secondary server:

- HDR Secondary: The current primary server is shut down and the HDR secondary server is made the primary server.
- RS secondary: The RS secondary server is changed to a standard server.
- SD secondary: The SD secondary server is made the new primary server.

Use the **ha make primary** argument to change an inactive secondary server to a primary server when there is an active connection between them.

Use the **ha make primary force** argument to change an inactive secondary server to a primary server, whether or not a secondary server is connected to it. If the connection is active, the function succeeds, however, if you run the function with the **force** argument on an SD secondary server, the shared disk subsystem can become corrupted.

This function is equivalent to the **onmode -d make primary** command.

Example

The following example converts an HDR secondary server named **ids_stores2** into a primary server:

```
EXECUTE FUNCTION task("ha make primary","ids_stores2");
```

Related reference:

“onmode -d: Set High Availability server characteristics” on page 15-9

ha rss argument: Create an RS secondary server (SQL administration API)

Use the **ha rss** argument with the **admin()** or **task()** function to create a remote standalone (RS) secondary server.

Syntax

```
►► EXECUTE FUNCTION admin ( task )  
► "ha rss" , —"primary_server" , —"password" ) ;
```

Element	Description	Key Considerations
<i>password</i>	A password to set or to change.	The password is used only during the first connection attempt. After the primary and secondary server have connected, the password cannot be changed.
<i>primary_server</i>	The name of the primary database server.	The name must be defined in the DBSERVERNAME or DBSERVERALIASES configuration parameter, or as an Enterprise Replication group name.

Usage

Run this function on a standard server or an HDR secondary server to convert it an RS secondary server.

This function is equivalent to the **onmode -d RSS** command.

Example

The following example converts a standard server into an RS secondary server with a primary server named **ids_stores**:

```
EXECUTE FUNCTION task("ha rss","ids_stores");
```

Related reference:

“onmode -d: Set High Availability server characteristics” on page 15-9

ha rss add argument: Add an RS secondary server to a primary server (SQL administration API)

Use the **ha rss add** argument with the **admin()** or **task()** function to associate a primary server with a remote standalone (RS) secondary server.

Syntax

```
►► EXECUTE FUNCTION admin ( task )  
►► "ha rss add" , —"secondary_server" , ,"password" ) ;
```

Element	Description	Key Considerations
<i>password</i>	The password to set or to change.	The password is used only during the first connection attempt. After the primary and secondary server have connected, the password cannot be changed.
<i>secondary_server</i>	The name of the database server to convert to an RS secondary server.	The name must be defined in the DBSERVERNAME or DBSERVERALIASES configuration parameter, or as an Enterprise Replication group name.

Usage

Run this function from an established primary server to create an RS secondary server and register the RS secondary server name in the **sysha** database.

This function is equivalent to the **onmode -d add RSS** command.

Example

The following example associates a server named **ids_stores2** as an RS secondary server with the primary server:

```
EXECUTE FUNCTION task("ha rss add","ids_stores2");
```

Related reference:

“onmode -d: Set High Availability server characteristics” on page 15-9

ha rss change argument: Change the password of an RS secondary server (SQL administration API)

Use the **ha rss change** argument with the **admin()** or **task()** function to change the connection password for the specified RS secondary server.

Syntax

```
►► EXECUTE FUNCTION admin  
task (  )  
►► "ha rss change"—,"secondary_server"— , —"password"—) ;
```

Element	Description	Key Considerations
<i>password</i>	The password to set or to change.	The password is used only during the first connection attempt. After the primary and secondary server have connected, the password cannot be changed.
<i>secondary_server</i>	The name of the database server to convert to an RS secondary server.	The name must be defined in the DBSERVERNAME or DBSERVERALIASES configuration parameter, or as an Enterprise Replication group name.

Usage

Run this function on an established primary server to change the password for the connection between the primary and secondary server.

This function is equivalent to the **onmode -d change RSS** command.

Example

The following example changes the password for the RS secondary server to secure:

```
EXECUTE FUNCTION task("ha rss change","ids_stores2","secure");
```

Related reference:

“onmode -d: Set High Availability server characteristics” on page 15-9

ha rss delete argument: Delete an RS secondary server (SQL administration API)

Use the **ha rss delete** argument with the **admin()** or **task()** function to stop replication and delete the RS secondary server.

Syntax

```
►► EXECUTE FUNCTION admin (task) ("ha rss delete", "secondary_server")  
►►);
```

Element	Description	Key Considerations
<i>secondary_server</i>	The name of the database server to convert to an RS secondary server.	The name must be defined in the DBSERVERNAME or DBSERVERALIASES configuration parameter, or as an Enterprise Replication group name.

Usage

Run this function from an established primary server to stop replication, delete the RS secondary server, and convert the RS secondary server to a standard server.

This function is equivalent to the **onmode -d delete RSS** command.

Example

The following example deletes the RS secondary server named **ids_stores2**:

```
EXECUTE FUNCTION task("ha rss delete","ids_stores2");
```

Related reference:

“onmode -d: Set High Availability server characteristics” on page 15-9

ha sds clear argument: Stop shared-disk replication (SQL administration API)

Use the **ha sds clear** argument with the **admin()** or **task()** function to stop replication to shared disk (SD) secondary servers and convert the primary server to a standard server.

Syntax

```
►► EXECUTE FUNCTION admin (task) ("ha sds clear", "primary_server")  
►►);
```

Element	Description	Key Considerations
<i>primary_server</i>	The name of the primary server to convert to a standard server.	The name must be defined in the DBSERVERNAME or DBSERVERALIASES configuration parameter, or as an Enterprise Replication group name.

Usage

Run this function on an established primary server to stop replication to the SD secondary servers.

This function is equivalent to the **onmode -d clear SDS primary** command.

Example

The following example stops replication from the primary server named **ids_stores** to SD secondary servers:

```
EXECUTE FUNCTION task("ha sds clear","ids_stores");
```

Related reference:

“onmode -d: Set High Availability server characteristics” on page 15-9

ha sds primary argument: Convert an SD secondary server to a primary server (SQL administration API)

Use the **ha sds primary** argument with the **admin()** or **task()** function to change a shared disk (SD) secondary server to a primary server.

Syntax

```

▶▶ EXECUTE FUNCTION admin ("ha sds primary"
task ("ha sds primary force"
▶▶ , "secondary_server") —);

```

Element	Description	Key Considerations
<i>secondary_server</i>	The name of the SD secondary server to set as a primary server.	The name must be defined in the DBSERVERNAME or DBSERVERALIASES configuration parameter, or as an Enterprise Replication group name.

Usage

Run this function on an established SD secondary server to convert it to the primary server.

Use the **ha sds primary** argument to convert an inactive SD secondary server to a primary server, if the SD secondary servers are connected to it.

Use the **ha sds primary force** argument to convert an inactive SD secondary server to a primary server, whether or not any SD secondary servers are connected to it. If sessions are active, the call succeeds, but the shared disk subsystem can become corrupted.

This function is equivalent to the **onmode -d make primary** command.

Example

The following example converts an SD secondary server named **ids_stores3** to the primary server:

```
EXECUTE FUNCTION task("ha sds primary","ids_stores3");
```

Related reference:

“onmode -d: Set High Availability server characteristics” on page 15-9

ha sds set argument: Create a shared-disk primary server (SQL administration API)

Use the **ha sds set** argument with the **admin()** or **task()** function to define a primary server to replicate to shared disk (SD) secondary servers.

Syntax

```
▶▶ EXECUTE FUNCTION admin ("ha sds set" "ha sds set force")
task
▶▶ ,—"primary_server"—);
```

Element	Description	Key Considerations
<i>primary_server</i>	The name of the database server to set as a primary server.	The name must be defined in the DBSERVERNAME or DBSERVERALIASES configuration parameter, or as an Enterprise Replication group name.

Usage

Run this function on a standard server to define it as a primary server for SD secondary servers.

Use the **ha sds set** argument to define an inactive standard server as a primary server, if the SD secondary servers are connected to it.

Use the **ha sds set force** argument to define an inactive standard server as a primary server, whether or not any SD secondary servers are connected to it. If sessions are active, the call succeeds, but the shared disk subsystem can become corrupted.

This function is equivalent to the **onmode -d set SDS primary** command.

Example

The following example converts a standard server named `ids_stores` to a primary server:

```
EXECUTE FUNCTION task("ha sds set","ids_stores");
```

Related reference:

“`onmode -d`: Set High Availability server characteristics” on page 15-9

ha set idxauto argument: Replicate indexes to secondary servers (SQL administration API)

Use the `ha set idxauto` argument with the `admin()` or `task()` function to control whether indexes are automatically replicated to secondary servers.

Syntax

```
►► EXECUTE FUNCTION admin ("ha set idxauto off") ; task ("ha set idxauto on") ;
```

Usage

Run this function on an established primary server to enable or disable automatic index replication to secondary servers.

You can run this function on any type of primary server.

This function is equivalent to the `onmode -d idxauto` command.

Example

The following example enables automatic index replication:

```
EXECUTE FUNCTION task("ha set idxauto on");
```

Related reference:

“`onmode -d` command: Replicate an index with data-replication” on page 15-11

ha set ipl argument: Log index builds on the primary server (SQL administration API)

Use the `ha set ipl` argument with the `admin()` or `task()` function to control whether to log index builds on the primary server.

Syntax

```
►► EXECUTE FUNCTION admin ("ha set ipl off") ; task ("ha set ipl on") ;
```

Usage

Run this function on an established primary server to enable or disable the logging of index builds. This function resets the value of the `LOG_INDEX_BUILDS` configuration parameter in the `ONCONFIG` file.

You can run this function on any type of primary server.

This function is equivalent to the **onmode -wf LOG_INDEX_BUILDS** command.

Example

The following example enables the logging of index builds:

```
EXECUTE FUNCTION task("ha set ipl on");
```

Related reference:

“onmode -wf, -wm: Dynamically change certain configuration parameters” on page 15-26

ha set primary argument: Define an HDR primary server (SQL administration API)

Use the **ha set primary** argument with the **admin()** or **task()** function to define a High-Availability Data Replication (HDR) primary server and specify the secondary server.

Syntax

```
▶▶ EXECUTE FUNCTION admin (task) ("ha set primary", "secondary_server")  
▶▶ ) ;
```

Element	Description	Key Considerations
<i>secondary_server</i>	The name of the HDR secondary server to connect to.	The name must be defined in the DBSERVERNAME or DBSERVERALIASES configuration parameter, or as an Enterprise Replication group name.

Usage

Run this function on a standard server to convert it to an HDR primary server and connect to the specified HDR secondary server. If the connection is successful, replication begins.

This function is equivalent to the **onmode -d primary** command.

Example

The following example converts a standard server named **ids_stores** to an HDR primary server:

```
EXECUTE FUNCTION task("ha set primary","ids_stores");
```

Usage

Run this function on an established HDR primary or secondary server to convert it to a standard server. The connection between the primary and secondary servers is dropped and replication stops. The mode of the other server in the HDR pair is not changed.

This function is equivalent to the **onmode -d standard** command.

Example

The following example converts an HDR secondary server to a standard server:

```
EXECUTE FUNCTION task("ha set standard");
```

Related reference:

“onmode -d: Set data-replication types” on page 15-7

ha set timeout argument: Change SD secondary server timeout (SQL administration API)

Use the **ha set timeout** argument with the **admin()** or **task()** function to change the amount of time in seconds that the primary server waits for acknowledgments from shared disk (SD) secondary servers.

Syntax

```
►► EXECUTE FUNCTION admin task ("ha set timeout"—,—"seconds"—);
```

Element	Description	Key Considerations
<i>seconds</i>	The number of seconds the primary server waits before disconnecting the SD secondary server.	The value must be a positive integer in the range: from 2 to 2 147 483 647

Usage

Run this function on an established shared disk primary server to specify the amount of time in seconds that the primary server waits for a log position acknowledgment to be sent from an SD secondary server. If there is no log position acknowledgment received from the SD secondary server in the specified amount of time, the primary server disconnects from the SD secondary server and continues. After waiting for the specified number of seconds, the primary server starts removing SD secondary servers if page flushing has timed out while waiting for an SD secondary server.

This function resets the value of the SDS_TIMEOUT configuration parameter in the ONCONFIG file.

This function is equivalent to the **onmode -wf SDS_TIMEOUT** command.

Example

The following example sets the timeout period to 5 seconds:

```
EXECUTE FUNCTION task("ha set timeout","5");
```

Related reference:

“onmode -wf, -wm: Dynamically change certain configuration parameters” on page 15-26

message log delete argument: Delete a message log file (SQL administration API)

Use the **message log delete** argument or **file delete** argument with the **admin()** or **task()** function to specify the particular online, ON-Bar activity, or ON-Bar debug message log to delete.

Syntax

```
▶ EXECUTE FUNCTION admin task ▶  
▶ ( "message log delete" , "file delete" , "full_path_for_message_log_file" ) ; ▶
```

Element	Purpose	Key considerations
<i>full_path_for_message_log_file</i>	Full path name for the particular online, ON-Bar activity, or ON-Bar debug message log file.	

Examples

The following examples show the arguments that you can use to delete the `/usr/informix/online.log` file:

```
execute function task("message log delete", "/usr/informix/online.log");
```

```
execute function task("file delete", "/usr/informix/online.log");
```

Related reference:

“message log rotate argument: Rotate the message log file (SQL administration API)”

“message log truncate argument: Delete the contents of a message log file (SQL administration API)” on page 22-65

“file status argument: Display the status of a message log file (SQL administration API)” on page 22-52

message log rotate argument: Rotate the message log file (SQL administration API)

Use the **message log rotate** argument or the **file rotate** argument with the **admin()** or **task()** function to specify the particular online, ON-Bar activity, or ON-Bar debug message log file to rotate, and to indicate the maximum number of message logs to rotate.

When the message log file rotates, the database server switches to a new online message log file and increments the ID numbers for the previous log files by one. When the maximum number of log files is reached, the log file with the highest ID is deleted.

Syntax

```

▶ EXECUTE FUNCTION admin
task
▶ ( "message log rotate" , "full_path_for_message_log_file"
"file rotate"
▶ maximum_version ) ;

```

Element	Purpose	Key considerations
<i>full_path_for_message_log_file</i>	Full path name of the online, ON-Bar activity, or ON-Bar debug message log file that the server will rotate, for example, /usr/informix/online.log.	
<i>maximum_version</i>	The log file with the highest ID. This is the maximum message log version that the server will rotate.	

Examples

The following examples show the arguments that you can use to rotate a maximum of 52 /usr/informix/online.log files:

```

execute function task("message log rotate", "/usr/informix/online.log",52);
execute function task("file rotate", "/usr/informix/online.log",52);

```

When the database server rotates these files, the server deletes version 52 of the file. Version 51 becomes version 52, version 50 becomes version 51, and so on. The new online log becomes version 1.

Related reference:

“message log truncate argument: Delete the contents of a message log file (SQL administration API)”

“message log delete argument: Delete a message log file (SQL administration API)” on page 22-64

“file status argument: Display the status of a message log file (SQL administration API)” on page 22-52

message log truncate argument: Delete the contents of a message log file (SQL administration API)

Use the **message log truncate** argument or **file truncate** argument with the **admin()** or **task()** function to specify the particular online, ON-Bar activity, or ON-Bar debug message log file to truncate. When the database server truncates a message log file, it deletes the messages in the log file, but keeps the log file.

Syntax

```

▶▶ EXECUTE FUNCTION { admin
                       task }
▶ ( ("message log truncate" ,—"full_path_for_message_log_file"—) ;
  ("file truncate"—) ;

```

Element	Purpose	Key considerations
<i>full_path_for_message_log_file</i>	Full path name for the online, ON-Bar activity, or ON-Bar debug message log file.	

Examples

The following examples show the arguments that you can use to truncate the `/usr/informix/online.log` file:

```

execute function task("message log truncate", "/usr/informix/online.log");
execute function task("file truncate", "/usr/informix/online.log");

```

Related reference:

“message log rotate argument: Rotate the message log file (SQL administration API)” on page 22-64

“message log delete argument: Delete a message log file (SQL administration API)” on page 22-64

“file status argument: Display the status of a message log file (SQL administration API)” on page 22-52

modify chunk extend argument: Extend the size of a chunk (SQL administration API)

Use the **modify chunk extend** argument with the **admin()** or **task()** function to extend the size of the chunk by a specified minimum amount. The chunk must be marked as extendable.

```

▶▶ EXECUTE FUNCTION { admin
                       task }
▶ (—"modify chunk extend"—,—"chunk_number"—,—"extend_amount"—) ;

```

Element	Description	Key Considerations
<i>chunk_number</i>	The number of the chunk.	
<i>extend_amount</i>	The minimum amount of space in kilobytes to add to the chunk.	See “admin() and task() Argument Size Specifications” on page 22-2.

Usage

You must mark a chunk as extendable before the chunk can be extended, either manually or automatically. Use the **modify chunk extendable** argument with the **admin()** or **task()** function to mark a chunk as extendable.

The **modify chunk extend** SQL administration API command is an alternative to the **adm_add_storage** task that the server can run to automatically extend the size of a chunk when the space containing the chunk runs low or out of free pages.

You cannot extend a chunk in a mirrored space, and you will receive an error if you provide the number of a mirror chunk when you run a **modify chunk extend** SQL administration API command.

To identify primary and mirror chunks in a mirrored space, look for the P (primary) or M (mirror) in position 1 of the flags field in **onstat -d** command output.

The server might round up the requested size, depending on the page size and the configured create size and extend size of the space.

Examples

Suppose that your **onstat -d** command output shows that chunk number 3 is a mirror chunk and chunk number 4 is not a mirror chunk. You cannot extend the size of chunk number 3. However, you can modify chunk number 4. The following command extends the size of chunk number 4 by 10000 kilobytes:

```
EXECUTE FUNCTION task("modify chunk extend", "4", "10000");
```

Related reference:

“modify chunk extendable argument: Mark a chunk as extendable (SQL administration API)”

“modify chunk extend argument: Extend the size of a chunk (SQL administration API)” on page 22-66

“modify space sp_sizes argument: Modify the create or extend size of a storage space (SQL administration API)” on page 22-70

“modify space expand argument: Expand the size of a space (SQL administration API)” on page 22-69

“**onstat -d** command: Print chunk information” on page 21-34

modify chunk extendable argument: Mark a chunk as extendable (SQL administration API)

Use the **modify chunk extendable** argument with the **admin()** or **task()** function to specify that a particular chunk in an unmirrored dbspace or temporary dbspace can be extended..

```
▶▶ EXECUTE FUNCTION [admin | task]
▶▶ ("—"modify chunk extendable"—,—"chunk_number"—) ; ▶▶▶▶
```

Element	Description	Key Considerations
<i>chunk_number</i>	The number of the chunk.	

Usage

If a chunk is marked as extendable, either:

- The server can automatically extend the chunk when the unmirrored dbspace or temporary dbspace containing the chunk runs low or out of free pages.
- You can use the **modify chunk extend** argument with the **admin()** or **task()** function to extend the size of the chunk.

However, if the extend size for the dbspace or temporary dbspace is set to 0, the server cannot automatically extend an extendable chunk in that space. In this situation, you can still manually extend the chunk.

The server will automatically mark chunks that are allocated from extendable storage pool entries as extendable. Therefore, you do not need to mark these chunks as extendable. For information on extendable storage pool entries, see “storagepool add argument: Add a storage pool entry (SQL administration API)” on page 22-120.

Chunks in mirrored spaces cannot be extended. If you try to make a mirror chunk extendable, you will receive an error.

To identify primary and mirror chunks in a mirrored space, look for the P (primary) or M (mirror) in position 1 of the flags field in **onstat -d** command output.

Example

The following snippet of **onstat -d** output shows that chunk number 3 is a mirror chunk:

Chunks address	chunk/dbs	offset	size	free	bpages	flags	pathname
451191c8	1	1	0	225000	101572	P0-B--	/reg1/rootchunk
451197d0	2	2	0	1250	1149	P0-B--	/reg1/dbs1
451199d0	3	3	0	1250	1149	P0-B--	/reg1/dbs2
46a36638	3	3	0	1250	0	M0-B--	/reg1/chunk2
45119bd0	4	4	0	1250	1149	P0-B--	/reg1/dbs3

Thus, you cannot extend the size of chunk number 3. However, you can specify that chunk number 4 is extendable, as follows:

```
EXECUTE FUNCTION sysadmin:task("modify chunk extendable", "4");
```

Related reference:

“modify chunk extendable off argument: Mark a chunk as not extendable (SQL administration API)”

“modify space sp_sizes argument: Modify the create or extend size of a storage space (SQL administration API)” on page 22-70

“modify chunk extend argument: Extend the size of a chunk (SQL administration API)” on page 22-66

“modify space expand argument: Expand the size of a space (SQL administration API)” on page 22-69

modify chunk extendable off argument: Mark a chunk as not extendable (SQL administration API)

Use the **modify chunk extendable off** argument with the **admin()** or **task()** function to specify that a particular chunk cannot be extended.

```

▶▶ EXECUTE FUNCTION admin
task
▶ (—"modify chunk extendable off"—,—"chunk_number"—) ;

```

Element	Description	Key Considerations
<i>chunk_number</i>	The number of the chunk.	

Usage

The default status for chunks is not extendable. If you previously marked a chunk as extendable, you can change the status to not extendable.

If a chunk is marked as not extendable:

- The server cannot automatically extend the chunk when the space containing the chunk runs low or out of free pages.
- You cannot manually extend the size of the chunk.

If the storage pool contains entries, the server can extend a storage space by adding another chunk to the storage space.

Example

The following example specifies that the you or the server cannot extend chunk 9:
EXECUTE FUNCTION task("modify chunk extendable off", "9");

Related reference:

“modify chunk extendable argument: Mark a chunk as extendable (SQL administration API)” on page 22-67

modify space expand argument: Expand the size of a space (SQL administration API)

Use the **modify space expand** argument with the **admin()** or **task()** function to immediately expand the size of a space, when you do not want to wait for Informix to automatically expand the space.

```

▶▶ EXECUTE FUNCTION admin
task ("—"modify space expand—"
▶ ,—"space_name"—,—"size"—);

```

Element	Description	Key Considerations
<i>space_name</i>	The name of the storage space.	
<i>size</i>	The minimum size by which you want to expand the space.	See “admin() and task() Argument Size Specifications” on page 22-2.

Usage

The **modify space expand** SQL administration API command expands a storage space immediately, either by extending an extendable chunk in the space or by adding a new chunk. The create size and extend size settings for the space do not affect this operation.

The actual number of kilobytes added to the space might exceed your requested size, depending on factors such as the page size of the space and the chunk size settings for available entries in the storage pool.

The storage pool must contain entries (such as raw devices, cooked files, or directories) that the server can use to expand the space.

After you run a **modify space expand** SQL administration API command, Informix first attempts to expand the space by extending an extendable chunk in the space. If the space does not contain any extendable chunks, the server uses entries in the storage pool to expand the space.

You cannot expand a mirrored storage space.

Examples

The following command expands dbspace5 by 10 megabytes:

```
EXECUTE FUNCTION task("modify space expand", "dbspace5", "10 MB");
```

Related reference:

“modify chunk extendable argument: Mark a chunk as extendable (SQL administration API)” on page 22-67

“modify chunk extend argument: Extend the size of a chunk (SQL administration API)” on page 22-66

“modify space sp_sizes argument: Modify the create or extend size of a storage space (SQL administration API)”

“create chunk from storagepool argument: Create a chunk from the storage pool (SQL administration API)” on page 22-30

modify space sp_sizes argument: Modify the create or extend size of a storage space (SQL administration API)

Use the **modify space sp_sizes** argument with the **admin()** or **task()** function to modify two different sizes that are associated with expanding a storage space, the extend size and the create size. Do this to control how Informix uses storage pool entries for a particular storage space.

```
▶▶ EXECUTE FUNCTION 

|       |
|-------|
| admin |
| task  |

 ( 

|            |
|------------|
| space_name |
|------------|

 , 

|                 |
|-----------------|
| new_create_size |
|-----------------|

 , 

|                 |
|-----------------|
| new_extend_size |
|-----------------|

 ) ;
```

Element	Description	Key Considerations
<i>space_name</i>	The name of the storage space.	

Element	Description	Key Considerations
<i>new_create_size</i>	The minimum size of a new chunk that the server can create when automatically expanding this space using the storage pool. You can define the size as a number of kilobytes or as a percentage of the total space.	The default create size is set to 10 percent of the total size of the space. The size you specify affects chunks the server creates automatically. It does not affect any manual chunks that you might create for the associated space.
<i>new_extend_size</i>	The minimum size that the server can use when automatically extending a chunk in an unmirrored dbspace or temporary dbspace. The size can be a specified number of kilobytes or a percentage of the total space.	The default extend size is 10 megabytes. The size you specify affects chunks the server extends automatically. It does not affect any manual chunk extensions that you might initiate for the associated space.

Usage

If the create or extend size value is 100 or a lower value, Informix interprets the value as a percentage (for example, 10 = 10 percent and 2.84 = 2.84 percent). If the value is 1000 or higher, the server interprets the value as a specific number of kilobytes. Values between 100 and 1000 are not valid.

If you set the create size and the extend size to 0, Informix does not automatically expand the space, even when the space becomes full. Additionally, if you set the extend size to 0, you also remove the "Extendable" flag from all chunks in that space. This is an easy way to mark all chunks in a space as not extendable, using one operation.

The create and extend size values are minimum sizes. The actual size by which a space is expanded might be larger, depending on the chunk size of the storage pool entry that the server is using or the amount of space that the server needs at that particular time.

For example, suppose you created a storage pool entry to expand storage space when necessary. Then suppose that a dbspace named "logdbs" is out of free pages and requires an additional 500 megabytes for a new log. If none of the chunks in logdbs can be extended, Informix adds a new chunk that has the minimum size specified by the create size value for the logdbs dbspace. If the create size for the logdbs dbspace is less than or equal to 500 megabytes, the server attempts to find a minimum of 500 megabytes of space. If the create size for logdbs is 1 gigabyte, the server ignores the requested size and adds a 1 gigabyte chunk.

If the server is unable to find the minimum amount of space required at any given point, the server returns an out-of-space error and the log creation fails.

Examples

The following command sets the minimum create size to 60 megabytes and the minimum extend size to 10 megabytes for dbspace3:

```
EXECUTE FUNCTION task("modify space sp_sizes", "dbspace3", "60000", "10000");
```

The following command sets the minimum create size to 20 percent and the minimum extend size 1.5 percent for dbspace8:

```
EXECUTE FUNCTION task("modify space sp_sizes", "dbspace8", "20", "1.5");
```

Related reference:

“modify chunk extendable argument: Mark a chunk as extendable (SQL administration API)” on page 22-67

“modify chunk extend argument: Extend the size of a chunk (SQL administration API)” on page 22-66

“modify space expand argument: Expand the size of a space (SQL administration API)” on page 22-69

onmode and a arguments: Add a shared-memory segment (SQL administration API)

Use the **onmode** and **a** arguments with the **admin()** or **task()** function to add a shared-memory segment.

Syntax

```
▶▶ EXECUTE FUNCTION admin (—"onmode"—,—"a"—,—"size"—);
```

└─task─┘

Element	Description	Key Considerations
<i>size</i>	The size, in kilobytes, of a new virtual shared-memory segment.	The value of <i>size</i> must be a positive integer that does not exceed the operating-system limit on the size of shared-memory segments.

Usage

Ordinarily, you do not need to add segments to the virtual portion of shared memory because the database server automatically adds segments as they are needed. However, as segments are added, the database server might reach the operating-system limit for the maximum number of segments before it acquires the memory that it needs. This situation typically occurs when the SHMADD configuration parameter is set so small that the database server exhausts the number of available segments before it acquires the memory that it needs for some operation.

You can use this function to add a segment that is larger than the size specified by the SHMADD configuration parameter. By using this function to add a segment, you can adhere to the operating system limit for segments while meeting the need that the database server has for more memory.

This function is equivalent to the **onmode -a** command.

Example

The following example adds 500 KB of virtual shared-memory:

```
EXECUTE FUNCTION task("onmode", "a", "500");
```

Related reference:

“onmode -a: Add a shared-memory segment” on page 15-2

onmode and c arguments: Force a checkpoint (SQL administration API)

Use the **onmode** and **c** arguments with the **admin()** or **task()** function to force a checkpoint.

Syntax

```
▶▶ EXECUTE FUNCTION admin task ("onmode", "c", "hard");
```

"hard"
"block"
"norm"
"unblock"

Usage

This function forces a checkpoint that flushes the buffers to disk. You can use the **c** option to force a checkpoint if the most recent checkpoint record in the logical log was preventing the logical-log file from being freed (status U-B-L).

Use the **block** argument to prevent the database server from processing any transactions. Use this option to perform an external backup on Informix. While the database server is blocked, users cannot access it, except in read-only mode. No transactions can complete until the database server is unblocked.

Use the **hard** argument to force a blocking checkpoint. This is the default.

Use the **norm** argument to force a nonblocking checkpoint.

Use the **unblock** argument to unblock the database server. When the database server is unblocked, data transactions and normal database server operations can resume. Use this option after you complete an external backup on Informix.

This function is equivalent to the **onmode -c** command.

Example

The following example starts a blocking checkpoint:

```
EXECUTE FUNCTION task("onmode","c","hard");
```

Related reference:

“onmode -c: Force a checkpoint” on page 15-4

onmode and C arguments: Control the B-tree scanner (SQL administration API)

Use the **onmode** and **C** arguments with the **admin()** or **task()** function to control the B-tree scanner for cleaning indexes of deleted items.

Syntax

```

>> EXECUTE FUNCTION admin (—"onmode"—,—"C"—,
task
)
(—"start"—,—"1"—,—"start_count"—,—"1"—,—"stop"—,—"1"—,—"stop_count"—,—"threshold"—,—"thresh_size"—,—"duration"—,—"dur_num"—,—"range_size"—,—"alice"—,—"alice_mode"—,—"compression"—,—"compression_level"—);

```

Element	Description	Key Considerations
<i>alice_mode</i>	The alice mode for the system.	Valid integer values range from 0 (OFF) to 12.
<i>compression_level</i>	For a database server instance, the level at which two partially used index pages are merged. The pages are merged if the data on those pages totals a set level.	Valid values for the level are low, med (medium), high, and default. The system default value is med.
<i>dur_num</i>	The number of seconds that the hot list is valid.	After this number of seconds expires, the hot list will be rebuilt by the next available B-tree scanner thread, even if unprocessed items are on the list. Scanners that are processing requests are not interrupted.
<i>range_size</i>	The size of an index before index range cleaning is enabled.	A size of -1 can be used to disable range scanning.
<i>start_count</i>	The number of B-tree scanner threads to start.	If <i>start_count</i> is not specified, 1 more thread is started. A maximum of 32 threads can be started at one time. But, there is no limit on the number of scanner threads run simultaneously.

Element	Description	Key Considerations
<i>stop_count</i>	The number of B-tree scanner threads to stop.	If <i>stop_count</i> is not specified, a single thread is stopped. Stopping all index scanners prevents all index cleaning. If you specify a larger <i>stop_count</i> value than the number of threads that are running, no error is issued, but all scanner threads are stopped.
<i>thresh_size</i>	The minimum number of deleted items an index must encounter before an index is placed on the hot list.	After all indexes above the threshold have been cleaned and there is no other work for the B-tree scanner to do, the indexes below the threshold are added to the hot list.

Usage

The B-tree scanner has statistical information that tracks index efficiency and how much extra work the index places on the server. Based on the amount of extra work the index has accomplished because of committed deleted index items, the B-tree scanner develops an ordered list of indexes that have caused the server to do extra work, called the hot list. The index causing the highest amount of extra work is cleaned first and the rest of the indexes are cleaned in descending order. The DBA can allocate cleaning threads dynamically to configure workloads.

This function is equivalent to the **onmode -C** command.

Example

The following commands start 60 B-tree scanner threads:

```
EXECUTE FUNCTION admin("onmode","C","start","30");
EXECUTE FUNCTION admin("onmode","C","start","30");
```

The following command stops all of these threads:

```
EXECUTE FUNCTION admin("onmode","C","stop","30000");
```

No error is issued when the *stop_count* value is greater than the number of running threads.

Related reference:

“onmode -C: Control the B-tree scanner” on page 15-5

“BTSCANNER Configuration Parameter” on page 1-34

onmode and d arguments: Set data-replication types (SQL administration API)

Use the **onmode** and **d** arguments with the **admin()** or **task()** function to change the mode of a server participating in high-availability data replication (HDR).

Syntax

```
►► EXECUTE FUNCTION admin  
task ("onmode"—,"d"—,—————►
```



Element	Description	Key Considerations
<i>dbserver</i>	The name of the primary or secondary database server.	The <i>dbserver</i> name must correspond to the name specified in the DBSERVERNAME configuration parameter in the ONCONFIG file of the intended secondary database server. The name should <i>not</i> correspond to one of the database servers that the DBSERVERALIASES configuration parameter specifies.

Usage

Use this function to set the High-Availability Data Replication type as standard, primary, or secondary. You can use the **primary** and **secondary** arguments only when the database server is in quiescent mode. You can use the **standard** argument when the database server is in quiescent, online, or read-only mode.

The *dbserver* argument of the other database server in the data-replication pair and the type of a database server (standard, primary, or secondary) is preserved after reinitialization of shared memory.

The **standard** argument drops the connection between database servers in a data replication pair (if one exists) and sets the database server type of the current database server to standard. This option does not change the mode or type of the other database server in the pair.

The **primary** and *dbserver* arguments set the database server type to primary and attempt to connect with the database server that *dbserver* specifies. If the connection is successful, data replication is turned on. The primary database server goes into online mode, and the secondary database server goes into read-only mode. If the connection is not successful, the database server comes to online mode, but data replication is not turned on.

The **secondary** and *dbserver* arguments set the database server type to secondary and attempt to connect with the database server that *dbserver* specifies. If the connection is successful, data replication is turned on. The primary database server goes online, and the secondary database server goes into read-only mode. If the connection is not successful, the database server comes to read-only mode, but data replication is not turned on.

This function is equivalent to the **onmode -d** command.

Example

The following example sets a server named **ids_stores** as an HDR primary server:

```
EXECUTE FUNCTION task("onmode","d","primary","ids_stores");
```

Related reference:

“onmode -d: Set data-replication types” on page 15-7

onmode and D arguments: Set PDQ priority (SQL administration API)

Use the **onmode** and **D** arguments with the **admin()** or **task()** function to temporarily reset the PDQ resources that the database server can allocate to any one decision-support query.

Syntax

```
▶▶ EXECUTE FUNCTION admin (task ("onmode" , "D" , "max_priority" ) ;
```

Element	Description	Key Considerations
<i>max_priority</i>	The percentage of the user-requested PDQ resources actually allocated to the query.	The value must be an unsigned integer from 0 to 100.

Usage

Use this function to override the limit set by the MAX_PDQPRIORITY configuration parameter while the database server is online. The new values affect only the current instance of the database server; the values are not recorded in the **onconfig** file. If you shut down and restart the database server, the values of the parameter reverts to the values in the **onconfig** file.

This function is equivalent to the **onmode -D** command.

Example

The following example sets the percentage of PDQ resources that can be allocated to a query to 50 percent:

```
EXECUTE FUNCTION task("onmode","D","50");
```

Related reference:

“onmode -D, -M, -Q, -S: Change decision-support parameters” on page 15-12

onmode and e arguments: Change usage of the SQL statement cache (SQL administration API)

Use the **onmode** and **e** arguments with the **admin()** or **task()** function to temporarily change the mode of the SQL statement cache.

Syntax

```
▶▶ EXECUTE FUNCTION admin (task ("onmode" , "e" , "enable" ) ;
```

Usage

Use the **enable** argument to enable the SQL statement cache if it is disabled. Individual user sessions can use the statement cache only after they perform either of the following actions:

- Set the environment variable **STMT_CACHE** to 1.
- Execute the SQL statement **SET STATEMENT CACHE ON**.

Use the **flush** argument to flush the statements that are not in use from the SQL statement cache, which remains enabled. After the cache is flushed, the **onstat -g ssc ref_cnt** field shows 0.

Use the **off** argument to turn off the SQL statement cache, so that no statements are cached.

Use the **on** argument to cache all statements except those a user turns off by one of the following actions:

- Use this command to specify the OFF mode.
- Set the environment variable **STMT_CACHE** to 0.
- Execute the SQL statement **SET STATEMENT CACHE OFF** statement.

This function cannot modify the **STMT_CACHE** configuration parameter setting in the **ONCONFIG** file, but the last argument overrides that setting (or the default value, if **STMT_CACHE** is not set). Any changes to the statement cache behavior that you make with this command are in effect for the current database server session only. When you restart the database server, it uses the setting of the **STMT_CACHE** parameter in the **ONCONFIG** file. If the **STMT_CACHE** configuration parameter is not defined in the **ONCONFIG** file, the server does not use a statement cache.

This function is equivalent to the **onmode -e** command.

Example

The following example enables the SQL statement cache:

```
EXECUTE FUNCTION task("onmode","e","enable");
```

Related reference:

“onmode -e: Change usage of the SQL statement cache” on page 15-14

onmode and F arguments: Free unused memory segments (SQL administration API)

Use the **onmode** and **F** arguments with the **admin()** or **task()** function to free unused memory segments.

Syntax

```
▶▶ EXECUTE FUNCTION admin task ("onmode", "F"); ▶▶
```

Usage

When you execute this function, the memory manager examines each memory pool for unused memory. The memory manager immediately frees unused blocks of memory that it locates. After the memory manager checks each memory pool, it begins checking memory segments and frees any that the database server no longer needs.

Running this command causes a significant degradation of performance for any users that are active when you execute the utility. Although the execution time is brief (1 to 2 seconds), degradation for a single-user database server can reach 100 percent. Systems with multiple CPU virtual processors experience proportionately less degradation.

To confirm that the unused memory was freed, check the message log. If the memory manager frees one or more segments, it displays a message that indicates how many segments and bytes of memory were freed.

Tip: Run this command from an operating-system scheduling facility regularly and after the database server performs any function that creates more memory segments, including large index builds, sorts, or backups.

This function is equivalent to the **onmode -F** command.

Example

The following example frees unused memory blocks:

```
EXECUTE FUNCTION task("onmode","F");
```

Related reference:

“onmode -F: Free unused memory segments” on page 15-14

onmode and j arguments: Switch the database server to administration mode (SQL administration API)

Use the **onmode** and **j** arguments with the **admin()** or **task()** function to change the database server to administration mode.

Syntax

```
▶▶ EXECUTE FUNCTION admin task ("onmode",—"j"—);
```

Usage

When the server is changed to administration mode, all sessions lose their connection to the database server except for sessions of the following users:

- User **informix**
- Users in the **DBSA** group
- Users who are identified in **ADMIN_MODE_USERS** settings

This function is equivalent to the **onmode -j** command.

Example

The following example changes the server to administration mode:

```
EXECUTE FUNCTION task("onmode","j");
```

Related reference:

“onmode -k, -m, -s, -u, -j: Change database server mode” on page 15-16

onmode and l arguments: Switch to the next logical log (SQL administration API)

Use the **onmode** and **l** arguments with the **admin()** or **task()** function to switch the current logical-log file to the next logical-log file.

Syntax

```
▶▶ EXECUTE FUNCTION admin (-"onmode"-, -"l"-);▶▶  
task
```

Usage

This function is equivalent to the **onmode -l** command.

For information on switching to the next logical-log file, see the section on managing logical-log files in the *IBM Informix Administrator's Guide*.

Example

The following example moves the logical log out of the **root** chunk

```
SELECT task("onmode", "l") FROM sysmaster:syslogfil  
WHERE chunk = 1 AND sysmaster:bitval(flags,"0x02")>0;
```

Related reference:

“onmode -l: Switch the logical-log file” on page 15-19

onmode and m arguments: Switch to multi-user mode (SQL administration API)

Use the **onmode** and **m** arguments with the **admin()** or **task()** function to change the database server to multi-user mode.

Syntax

```
▶▶ EXECUTE FUNCTION admin (-"onmode"-, -"m"-);▶▶  
task
```

Usage

Use this function to bring the database server online from quiescent mode or from administration mode.

This function is equivalent to the **onmode -m** command.

Example

The following example changes the server to multi-user mode:

```
EXECUTE FUNCTION task("onmode","m");
```

Related reference:

“onmode -k, -m, -s, -u, -j: Change database server mode” on page 15-16

onmode and M arguments: Temporarily change decision-support memory (SQL administration API)

Use the **onmode** and **M** arguments with the **admin()** or **task()** function to temporarily change the size of memory available for parallel queries.

Syntax

```
►► EXECUTE FUNCTION admin task ("onmode",—"M"—,—"size"—); ◀◀
```

Element	Description	Key Considerations
<i>size</i>	The new size limit (in kilobytes) of the maximum amount of memory available for parallel queries.	The maximum value for 32-bit platform is 2 gigabytes. The maximum value for 64-bit platform is 4 gigabytes.

Usage

Use this function to override the limit set by the DS_TOTAL_MEMORY configuration parameter while the database server is online. The new values affect only the current instance of the database server; the values are not recorded in the ONCONFIG file. If you shut down and restart the database server, the values of the parameter revert to the values in the ONCONFIG file.

This function is equivalent to the **onmode -M** command.

Example

The following example sets the size limit for parallel queries to 50 MB:

```
EXECUTE FUNCTION task("onmode","M","50000");
```

Related reference:

"onmode -D, -M, -Q, -S: Change decision-support parameters" on page 15-12

onmode and n arguments: Unlock resident memory (SQL administration API)

Use the **onmode** and **n** arguments with the **admin()** or **task()** function to end forced residency of the resident portion of shared memory.

Syntax

```
▶▶ EXECUTE FUNCTION admin (-"onmode"-,-"n"-)-;  
                  task
```

Usage

The RESIDENT configuration parameter must be set to 1 in the ONCONFIG file before you can run this function.

This function does not affect the value of the RESIDENT configuration parameter, the forced-residency parameter in the ONCONFIG file.

This function is equivalent to the **onmode -n** command.

Example

The following example unlocks resident memory:

```
EXECUTE FUNCTION task("onmode","n");
```

Related reference:

"onmode -n, -r: Change shared-memory residency" on page 15-19

onmode and O arguments: Mark a disabled dbspace as down (SQL administration API)

Use the **onmode** and **O** arguments with the **admin()** or **task()** function to mark a disabled dbspace as down so that the checkpoint that is being blocked by the disabled dbspace can continue and any blocked threads are released.

Syntax

```
▶▶ EXECUTE FUNCTION admin (-"onmode"-,-"O"-)-;  
                  task
```

Usage

This function overrides the WAIT mode of the ONDBSPACEDOWN configuration parameter. Use this command only in the following circumstances:

- ONDBSPACEDOWN is set to WAIT.
- A disabling I/O error occurs that causes the database server to block all updating threads.

- You cannot or do not want to correct the problem that caused the disabling I/O error.
- You want the database server to mark the disabled dbspace as down and continue processing.

This function is equivalent to the **onmode -O** command.

Example

The following example marks disabled dbspaces as down:

```
EXECUTE FUNCTION task("onmode","0");
```

Related reference:

“onmode -O: Override ONDBSPACEDOWN WAIT mode” on page 15-20

onmode and p arguments: Add or remove virtual processors (SQL administration API)

Use the **onmode** and **p** arguments with the **admin()** or **task()** function to dynamically add or remove virtual processors for the current database server session. This function does not update the onconfig file.

Syntax

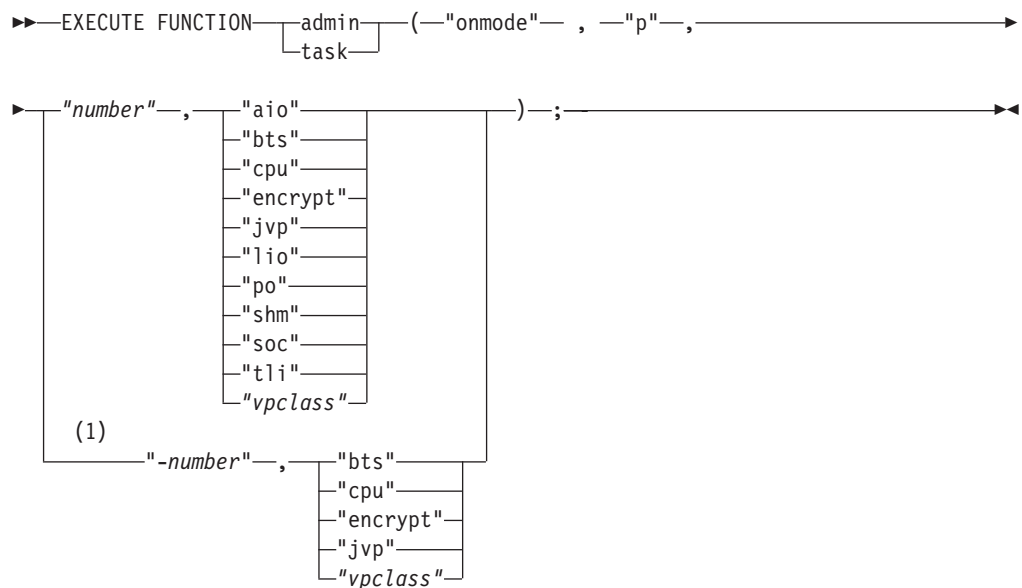

Notes:

- 1 UNIX only

Element	Description	Key Considerations
<i>number</i>	The number of virtual processors to add or to remove.	<p>A positive number adds virtual processors. The maximum number of virtual processors you can add depends on the operating system.</p> <p>UNIX: A negative number removes virtual processors. The number of virtual processors to drop cannot exceed the actual number of processors of the specified type.</p>

Element	Description	Key Considerations
<i>vpclass</i>	The name of a user-defined virtual processor class.	Windows: The <i>number</i> argument must be set to 1 because you can only create one instance of a user-defined virtual processor.

Usage

You can use this function only when the database server is in online mode.

The number of CPU VPs should not exceed the number of physical processors on your system, but no error is issued if they do. The database server uses the number of CPU VPs to allocate resources for parallel database queries (PDQ). If you drop CPU VPs, your queries might run significantly slower. After you change the number of CPU VPs, the **Reinit** field in the output from the **onstat -g mgm** command shows how many queries are waiting for other queries to complete.

See the *IBM Informix Performance Guide* for more information about performance implications of the CPU VP class.

For a description of each virtual processor class, see the *IBM Informix Administrator's Guide*.

This function is equivalent to the **onmode -p** command.

Example

The following example adds one CPU virtual processor:

```
EXECUTE FUNCTION task("onmode","p","1","cpu");
```

The following example removes one Java virtual processor:

```
EXECUTE FUNCTION task("onmode","p","-1","jvp");
```

Related reference:

“onmode -p: Add or remove virtual processors” on page 15-20

onmode and Q arguments: Set maximum number for decision-support queries (SQL administration API)

Use the **onmode** and **Q** arguments with the **admin()** or **task()** function to change the maximum number of concurrently executing decision-support queries.

Syntax

```
▶▶ EXECUTE FUNCTION admin task ("onmode",—"Q"—,—"queries"—);▶▶
```

Element	Description	Key Considerations
<i>queries</i>	The maximum number of concurrently executing parallel queries.	The number must be an unsigned integer from 1 to 8,388,608.

Usage

Use this function to override the limit set by the DS_MAX_QUERIES configuration parameter while the database server is online. The new values affect only the current instance of the database server; the values are not recorded in the ONCONFIG file. If you shut down and restart the database server, the values of the parameter revert to the values in the ONCONFIG file.

For information on parameters used for controlling PDQ, see the *IBM Informix Performance Guide*.

This function is equivalent to the **onmode -Q** command.

Example

The following example sets the maximum number of concurrently executing parallel queries to 8:

```
EXECUTE FUNCTION task("onmode","Q","8");
```

Related reference:

“onmode -D, -M, -Q, -S: Change decision-support parameters” on page 15-12

onmode and r arguments: Force residency of shared memory (SQL administration API)

Use the **onmode** and **r** arguments with the **admin()** or **task()** function to start forced residency of the resident portion of shared memory.

Syntax

```
▶▶ EXECUTE FUNCTION admin | task ("onmode", "r");
```

Usage

The RESIDENT configuration parameter must be set to 1 in the ONCONFIG file before you can run this function.

This function does not affect the value of the RESIDENT configuration parameter, the forced-memory parameter in the ONCONFIG file.

This function is equivalent to the **onmode -r** command.

Example

The following example starts forced residency of shared memory:

```
EXECUTE FUNCTION task("onmode","r");
```

Related reference:

“onmode -n, -r: Change shared-memory residency” on page 15-19

onmode and S arguments: Set maximum number of decision-support scans (SQL administration API)

Use the **onmode** and **S** arguments with the **admin()** or **task()** function to change the maximum number of concurrently executing decision-support scans for the current session.

Syntax

```
▶▶ EXECUTE FUNCTION admin (—"onmode"—,—"S"—,—"scans"—);
```

task

Element	Description	Key Considerations
<i>scans</i>	The maximum number of concurrently executing parallel scans.	The number must be an unsigned integer from 10 to 1 048 576.

Usage

Use this function to override the limit set by the DS_MAX_SCANS configuration parameter while the database server is online. The new value affects only the current instance of the database server; the values are not recorded in the ONCONFIG file. If you shut down and restart the database server, the value of the parameter reverts to the value in the ONCONFIG file.

For information on parameters used for controlling PDQ, see the *IBM Informix Performance Guide*.

This function is equivalent to the **onmode -S** command.

Example

The following example sets the maximum number of concurrently executing parallel scans to 2000:

```
EXECUTE FUNCTION task("onmode","S","2000");
```

Related reference:

“onmode -D, -M, -Q, -S: Change decision-support parameters” on page 15-12

onmode and W arguments: Reset statement cache attributes (SQL administration API)

Use the **onmode** and **W** arguments with the **admin()** or **task()** function to change whether and when a statement can be inserted into the SQL cache.

Syntax

```
▶▶ EXECUTE FUNCTION admin (—"onmode"—,—"W"—,—————▶
```

task

```
▶ ("STMT_CACHE_HITS", "hits") ;
  ("STMT_CACHE_NOLIMIT", "value") ;
```

Element	Description	Key Considerations
<i>hits</i>	The number of hits (references) to a statement before it is fully inserted in the SQL statement cache.	Possible values are: <ul style="list-style-type: none"> • 0 = Insert all qualified statements and their memory structures in the cache. • 1 or more = Exclude ad hoc queries from entering the cache.
<i>value</i>	Whether statements are inserted in the SQL statement cache.	Possible values are: <ul style="list-style-type: none"> • 0 = The database server does not insert statements into the cache. • 1 = The database server always inserts statements in the cache.

Usage

Use this function to reset the value of the `STMT_CACHE_HITS` or `STMT_CACHE_NOLIMIT` configuration parameter while the database server is online. The new value affects only the current instance of the database server; the value is not recorded in the `ONCONFIG` file. If you shut down and restart the database server, the value of the parameter reverts to the value in the `ONCONFIG` file.

If you set the value of `STMT_CACHE_HITS` equal to 0, the database server inserts all qualified statements and their memory structures in the cache. If the value is greater than 0 and the number of times the SQL statement has been executed is less than the value of `STMT_CACHE_HITS`, the database server inserts *key-only* entries in the cache. The database server inserts qualified statements in the cache after the specified number of hits has occurred for the statement. The new value of `STMT_CACHE_HITS` displays in the **#hits** field of the `onstat -g ssc` output.

If none of the queries are shared, set `STMT_CACHE_NOLIMIT` to 0 to prevent the database server from allocating a large amount of memory for the statement cache.

This function is equivalent to the `onmode -W` command.

Example

The following example prevents ad hoc queries from entering the SQL statement cache:

```
EXECUTE FUNCTION task("onmode","W","STMT_CACHE_HITS","1");
```

Related reference:

“onmode -W: Change settings for the SQL statement cache” on page 15-25

onmode and wf arguments: Permanently update a configuration parameter (SQL administration API)

Use the **onmode** and **wf** arguments with the **admin()** or **task()** function to dynamically update the value of a configuration parameter in the **onconfig** file.

Syntax

```
►► EXECUTE FUNCTION admin  
task (  )  
►► "onmode"—,"wf"—,"configuration_parameter=value"—);
```

Element	Description	Key Considerations
<i>configuration_parameter</i>	The name of a configuration parameter.	The configuration parameter must be one that you can update dynamically. The list of configuration parameters that you can update dynamically is the same as for the onmode -wf command.
<i>value</i>	The new value or values for the configuration parameter.	The value must be valid for the configuration parameter. The format of the new value must conform exactly to the syntax for that configuration parameter.

Usage

Use this function to permanently update the value of a configuration parameter. The new value takes effect immediately and persists in the ONCONFIG file after the server restarts.

This function is equivalent to the **onmode -wf** command.

Example

The following example sets the value of the DYNAMIC_LOGS configuration parameter to 2 in the **onconfig** file:

```
EXECUTE FUNCTION task("onmode","wf","DYNAMIC_LOGS=2");
```

Related reference:

“onmode -wf, -wm: Dynamically change certain configuration parameters” on page 15-26

onmode and wm arguments: Temporarily update a configuration parameter (SQL administration API)

Use the **onmode** and **wm** arguments with the **admin()** or **task()** function to dynamically update the value of a configuration parameter in memory.

Syntax

```
▶ EXECUTE FUNCTION admin  
task (  )  
▶ "onmode"—,"wm"—,"configuration_parameter=value"—);
```

Element	Description	Key Considerations
<i>configuration_parameter</i>	The name of a configuration parameter.	The configuration parameter that you specify must be one that you can update dynamically. The list of configuration parameters that you can update dynamically is the same as for the onmode -wf command.
<i>value</i>	The new value or values for the configuration parameter.	The value must be valid for the configuration parameter. The format of the new value must conform exactly to the syntax for that configuration parameter.

Usage

Use this function to temporarily update the value of a configuration parameter that can be dynamically updated. The new value takes effect immediately. The new value is not written to the ONCONFIG file and is lost when the database server is restarted.

This function is equivalent to the **onmode -wm** command.

Example

The following example sets the value of the DYNAMIC_LOGS configuration parameter to 2 for the current session:

```
EXECUTE FUNCTION task("onmode","wm","DYNAMIC_LOGS=2");
```

Related reference:

“onmode -wf, -wm: Dynamically change certain configuration parameters” on page 15-26

onmode, wm, and AUTO_LRU_TUNING arguments: Change LRU tuning status (SQL administration API)

Use the **onmode**, **wm**, and **AUTO_LRU_TUNING** arguments with the **admin()** or **task()** function to dynamically update LRU tuning status and the flushing behavior for the current session.

Syntax

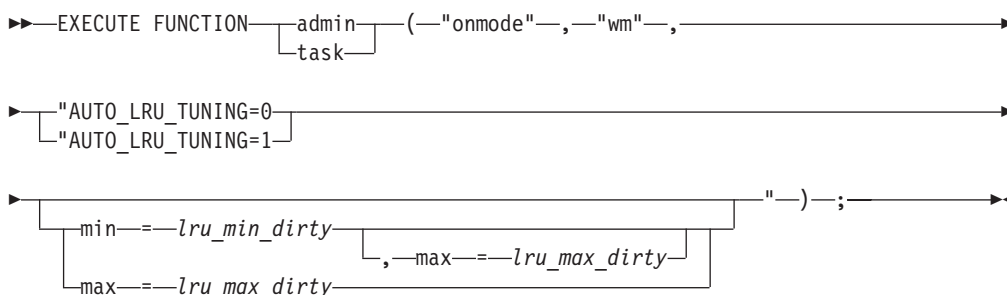

Element	Description	Key Considerations
<i>lru_max_dirty</i>	The percentage of modified pages in the LRU queues at which the queue is cleaned	If a value is specified out of the range of 0 through 100 (inclusive), the default of 60.00 percent is set. Fractional values are allowed.
<i>lru_min_dirty</i>	The percentage of modified pages in the LRU queues at which page cleaning is no longer mandatory. Page cleaners might continue cleaning beyond this point under some circumstances.	If a value is specified out of the range of 0 through 100 (inclusive), the default of 80.00 percent is set. Fractional values are allowed.

Usage

Use this function to change the LRU tuning status and also to specify flushing behavior for the current database server session. The ONCONFIG file is not updated.

Use the **AUTO_LRU_TUNING =1** argument to enable automatic LRU tuning for the current session.

Use the **AUTO_LRU_TUNING=0** argument to disable automatic LRU tuning for the current session.

Use the **min** and **max** arguments to reset the **lru_max_dirty** and **lru_min_dirty** values of the BUFFERPOOL configuration parameter. LRU flushing attributes can be set when automatic LRU tuning is either on or off. If the *lru_min_dirty* value is greater to or equal to the *lru_max_dirty* value for a specific buffer pool, the *lru_min_dirty* value is ignored and no error message is returned.

This function is equivalent to the **onmode -wm AUTO_LRU_TUNING** command.

Example

The following example enables automatic LRU tuning and sets LRU flushing attributes:

```
EXECUTE FUNCTION task("onmode","wm","AUTO_LRU_TUNING=1 min=50, max=70");
```

Related reference:

“onmode -wm: Change LRU tuning status” on page 15-28

onmode and Y arguments: Change query plan measurements for a session (SQL administration API)

Use the **onmode** and **Y** arguments with the **admin()** or **task()** function to change the output of query plan measurements for an individual session.

Syntax

```
▶▶ EXECUTE FUNCTION admin task ("onmode", -"Y"-"session_id", 0, 2, 1, , -file_name) ;
```

Element	Description	Key Considerations
<i>file_name</i>	The explain output file name.	If the file's absolute path is not included, the example output file is created in the default example output file location. If the file already exists, explain output is appended to it. If a file already exists from the SET EXPLAIN statement, that file is not used until dynamic explain is turned off.
<i>session_id</i>	Identifies the specific session.	None.
-Y	Dynamically change the value of the SET EXPLAIN statement.	None.

Usage

You can use this function to emulate the SET EXPLAIN statement.

The last argument determines if record query measurements, including the plan of the query optimizer, an estimate of the number of rows returned, and the relative cost of the query.

Use the **2** argument to enable the database server to send the query plan to the explain output file.

Use the **1** argument to enable the database server to send the query plan and statistics, to the explain output file. This setting is equivalent to the SET EXPLAIN ON statement for a specific session.

Use the **0** argument to disable the output of query measurements to the explain output file for the current session. This setting is equivalent to the SET EXPLAIN OFF statement.







This function is equivalent to the **onmode -Y** command.

Example

The following example disables the output of query measurements for user session with an ID of 32:

```
EXECUTE FUNCTION task("onmode","Y","32","0");
```

Related concepts:

-  Using the FILE TO option (SQL Syntax)
-  Default name and location of the explain output file on UNIX (SQL Syntax)
-  Default name and location of the output file on Windows (SQL Syntax)
-  Report that shows the query plan chosen by the optimizer (Performance Guide)
-  The explain output file (Performance Guide)
-  Query statistics section provides performance debugging information (Performance Guide)

Related reference:

“onmode -Y: Dynamically change SET EXPLAIN” on page 15-29

-  SET EXPLAIN statement (SQL Syntax)

onmode and z arguments: Terminate a user session (SQL administration API)

Use the **onmode** and **z** arguments with the **admin()** or **task()** function to terminate the specified user session.

Syntax

```
▶▶ EXECUTE FUNCTION admin (task ("onmode",—"z"—,—"session_ID"—);▶▶
```

Element	Description	Key Considerations
<i>session_ID</i>	The session ID.	The value must be an unsigned integer greater than 0, and must be the session identification number of a currently running session.

Usage

This function is equivalent to the **onmode -z** command.

Example

The following example terminates the user session with an ID of 14:

```
EXECUTE FUNCTION task("onmode","z","14");
```

Related reference:

“onmode -z: Kill a database server session” on page 15-30

onmode and Z arguments: Terminate a distributed transaction (SQL administration API)

Use the **onmode** and **Z** arguments with the **admin()** or **task()** function to terminate the specified distributed transaction. Use this function only if communication between the participating database servers has been lost. If applications are performing distributed transactions, terminating one of the distributed transactions can leave your client/server database system in an inconsistent state.

Syntax

```
▶▶ EXECUTE FUNCTION admin (—"onmode"—,—"Z"—,—"address"—);
```

task

Element	Description	Key Considerations
<i>address</i>	The shared-memory address associated with a distributed transaction.	This must be the address of an ongoing distributed transaction that has exceeded the amount of time that the TXTIMEOUT configuration parameter specifies. The <i>address</i> must conform to the operating-system-specific rules for addressing shared-memory. This address is available from onstat -x output.

Usage

This function succeeds only if the distributed transaction has exceeded the amount of time that the TXTIMEOUT configuration parameter specifies.

This function is equivalent to the **onmode -Z** command.

Example

The following example terminates a distributed transaction with an address of 0xa509018:

```
EXECUTE FUNCTION task("onmode","Z","0xa509018");
```

Related reference:

“onmode -Z: Kill a distributed transaction” on page 15-31

onbar argument: Backup the storage spaces (SQL administration API)

Use the **onbar** argument with the **admin()** or **task()** function to backup the storage spaces.

Syntax

```
▶▶ EXECUTE FUNCTION admin (—"onbar backup"—▶▶)
```

task

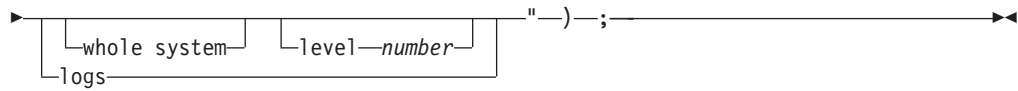

Element	Purpose	Key considerations
<code>onbar backup</code>	Performs a complete backup of the storage spaces	If you do not specify a level, a level 0 backup is performed.
<code>whole system</code>	Performs a whole-system backup	This is equivalent of issuing the onbar command with the <code>-w</code> option from the command line. If you do not specify a level, a level 0 backup is performed.
<code>level number</code>	Specifies the level of backup to perform on storage spaces: <ul style="list-style-type: none"> • 0 for a complete backup. This is the default. • 1 for changes since the last level-0 backup • 2 for changes since the last level-1 backup 	<p>If you request an incremental backup and a level backup has not been performed for a particular storage space, this function backs up that storage space at the previous level.</p> <p>For example, if you request a level-1 backup, and the function finds no level-0 backup, a level-0 backup is made instead.</p> <p>For more information, see Perform an incremental backup.</p> <p>This is equivalent of issuing the onbar command with the <code>-L level</code> option from the command line.</p>
<code>logs</code>	Performs a back of the logical-log files	This is equivalent of issuing the onbar command with the <code>-l</code> option from the command line.

Usage

This function is equivalent to invoking specific options of the **onbar** command to create backups of the storage spaces and logical-log files.

Examples

The following example creates a level 0 backup of the storage spaces:

```
EXECUTE FUNCTION task("onbar backup");
```

The following example creates a level 1 backup of the storage spaces:

```
EXECUTE FUNCTION task("onbar backup level 1");
```

The following example creates a level 1 backup of the logical-log files:

```
EXECUTE FUNCTION task("onbar backup logs");
```



The following example creates a whole system level 0 backup of the storage spaces:

```
EXECUTE FUNCTION task("onbar backup whole system");
```

The following example creates a whole system level 2 backup of the storage spaces:

```
EXECUTE FUNCTION task("onbar backup whole system level 2");
```

Related reference:

-  [Back up with ON-Bar \(Backup and Restore Guide\)](#)
-  [onbar -b syntax: Backing up \(Backup and Restore Guide\)](#)

onsmsync argument: Synchronize with the storage manager catalog (SQL administration API)

Use the **onsmsync** argument with the **admin()** or **task()** function to synchronize the **sysutils** database and emergency boot file with the storage manager catalog.

Syntax

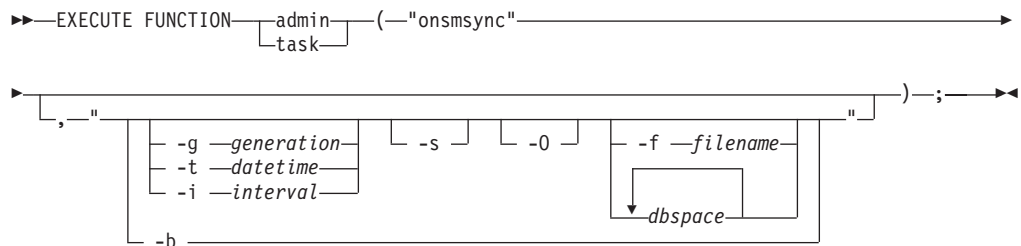

Element	Purpose	Key considerations
no options	Synchronizes the sysutils database and emergency boot file with the storage-manager catalog	None.
-b	Regenerates both the emergency boot file (<code>ixbar.servernum</code>) and the sysutils database from each other.	<p>If the <code>ixbar</code> file is empty or does not exist, onsmsync -b recreates the <code>ixbar</code> file and populates it from the sysutils tables.</p> <p>If the <code>ixbar</code> is not empty and contains object data, onsmsync -b updates the sysutils database and the <code>ixbar</code> file so that they are in sync.</p> <p>If the <code>ixbar</code> file has entries and the sysutils database has been rebuilt, but is empty because it does not contain data, the onsmsync -b option recreates the sysutils data from the <code>ixbar</code> file.</p> <p>The <code>-b</code> element is not used with the other onsmsync options. Additionally, it does not synchronize with the storage manager.</p>
<i>dbspace</i>	Specifies the storage space or storage spaces to expire	If you enter more than one storage space, use a space to separate the names.
-f <i>filename</i>	Specifies the path name of a file that contains a list of storage spaces to expire	Use this option to avoid entering a long list of storage spaces. The file name can be any valid UNIX or Windows file name.
-g <i>generation</i>	Retains a certain number of versions of each level-0 backup	The latest generation of backups are retained and all earlier ones are expired.
-i <i>interval</i>	Expires all backups older than some period of time	Retains backups younger than this interval. Backups older than interval are not expired if they are needed to restore from other backups after that interval. Use the ANSI or GLS format for the <i>interval</i> : YYYY-MM or DD HH:MM:SS

Element	Purpose	Key considerations
-s	Skips backups that the storage manager has expired	Use this option to skip synchronizing objects that are already expired from the storage manager. The object expiration will be based on other arguments if the -s option is provided.
-0	Enforces expiration policy strictly	If used with the -t, -g, or -i option, expires all levels of a backup, even if some of them are needed to restore from a backup that occurred after the expiration date. The -0 option does not affect logical-log expiration. See Expire all backups (Backup and Restore Guide).
-t <i>datetime</i>	Expires all backups before a particular date and time	Retains backups younger than this <i>datetime</i> . Backups older than <i>datetime</i> are not expired if they are needed to restore from other backups after that <i>datetime</i> . Use the ANSI or GLS_DATETIME format for <i>datetime</i> .

Usage

This function invokes the **onsmsync** utility to synchronize the **sysutils** database and emergency boot file with the storage manager catalog.

Example

The following example invokes the **onsmsync** utility and specifies that number of backups retained is 1 and all earlier backup versions are expired:

```
EXECUTE FUNCTION task("onsmsync", "-g 1");
```

Related reference:

 The onsmsync utility (Backup and Restore Guide)

ontape archive argument: Backup the data on your database (SQL administration API)

Use the **ontape archive** argument with the **admin()** or **task()** function to create a backup of your database data.

Syntax

```

▶▶ EXECUTE FUNCTION admin task ("ontape archive" directory file tape
▶ [level_number] ", -"location" -, ["block_size"] ) ;

```

Element	Description	Key Considerations
<i>number</i>	Valid levels are: 0, 1, or 2. The default value is 0.	
<i>location</i>	The path to the file or directory or tape device	
<i>block_size</i>	The block size of the device to which ontape writes during a storage-space backup	The default block size is 512 KB.

Usage

This function invokes the `ontape` utility to create a backup.

There are three devices that you can choose from for the location of the backup:

directory or dir

An existing directory path. The default backup device.

file An existing file.

tape An existing tape device.

Examples

This function creates a level 0 archive in the directory path `/local/informix/backup/`:

```
EXECUTE FUNCTION task("ontape archive", "/local/informix/backup/");
```

This function creates a level 0 archive in the directory path `/local/informix/backup/` with a block size of 256 KB:

```
EXECUTE FUNCTION task("ontape archive directory level 0",  
"/local/informix/backup/", "256");
```

Related reference:

 [Back up with ontape \(Backup and Restore Guide\)](#)

print error argument: Print an error message (SQL administration API)

Use the **print error** argument with the `admin()` or `task()` function to print the message associated with the specified error number.

Syntax

```
►► EXECUTE FUNCTION admin (task ("print error", error_number)) ; ◀◀
```

Element	Description	Key Considerations
<i>error_number</i>	The error number, without a minus sign.	The <i>error_number</i> must be an existing error number.

Usage

This function is equivalent to the `finderr` utility.

Example

The following example prints the message text for the error number -105:

```
EXECUTE FUNCTION task("print error", "105");  
(expression) ISAM error: bad isam file format.
```

print file info argument: Display directory or file information (SQL administration API)

Use the **print file info** argument with the **admin()** or **task()** function to display information about a directory or a file

Syntax

```
►►EXECUTE FUNCTION {admin|task} ("print file info",—"filepath"—);►►
```

Element	Purpose	Key considerations
<i>filepath</i>	The path to the directory or file	

Example: File information

The following example shows the argument you would use to print information about the x file that is in the /tmp directory:

```
execute function task("print file info", "/tmp/x");
```

The following information is returned:

```
(expression) File name           = /tmp/x
              Is File             = 1
              Is Directory         = 0
              Is Raw Device        = 0
              Is Block Device      = 0
              Is Pipe              = 0
              File Size            = 554
              Last Access Time     = 11/29/2010 21:55:02
              Last Modified Time   = 11/29/2010 21:51:45
              Status Change Time   = 11/29/2010 21:51:45
              User Id              = 200
              Group id             = 102
              File Flags           = 33206
```

Example: Directory information

The following example shows the argument that you would use to print information about the /tmp directory:

```
execute function task("print file info", "/tmp");
```

The following information is returned:

```
(expression) File name           = /tmp
              Is File             = 0
              Is Directory         = 1
              Is Raw Device        = 0
              Is Block Device      = 0
              Is Pipe              = 0
              File Size            = 32768
              Last Access Time     = 12/06/2010 11:53:00
              Last Modified Time   = 12/06/2010 12:05:53
              Status Change Time   = 12/06/2010 12:05:53
              User Id              = 0
              Group id             = 0
              File Flags           = 17407
```

print partition argument: Print partition information (SQL administration API)

Use the **print partition** argument with the **admin()** or **task()** function to print the headers of a specified partition.

Syntax

```
▶—EXECUTE FUNCTION admin task—————▶  
  
▶—("print partition" "print partition full" ,"partition_number")—;—————▶
```

Element	Description	Key Considerations
<i>partition_number</i>	The partition number.	Find the partition numbers in the partnum column of the systables system catalog table.

Usage

Use this function to print a tblspace report for the specified partition.

Run this function with the **full** argument to include index-specific information and page-allocation information by page type for dbspaces.

This function with the **print partition** argument is equivalent to the **oncheck -pt** command.

This function with the **print partition full** argument is equivalent to the **oncheck -pT** command.

Example

The following example prints the headers for a partition with a number of 1048611:
EXECUTE FUNCTION task("print partition","1048611");

Related reference:

“oncheck -pt and -pT: Display tblspaces for a Table or Fragment” on page 9-19

rename space argument: Rename a storage space (SQL administration API)

Use the **rename space** argument with the **admin()** or **task()** function to rename a dbspace, blobspace, sbospace, or extspace.

Syntax

```
▶—EXECUTE FUNCTION admin task ("rename space" ,"space" ,"new_name")  
  
▶—);—————▶
```

Element	Description	Key Considerations
<i>new_name</i>	The new name of the space.	
<i>space</i>	The name of the dbspace, blobspace, sbspace, or extspace that you want to rename.	

Usage

This function is equivalent to the **onspaces -ren** command.

Example

The following example renames a dbspace named **dbsp1** to **dbsp2**:

```
EXECUTE FUNCTION task("rename space","dbsp1","dbsp2");
```

Related reference:

“onspaces -ren: Rename a dbspace, blobspace, sbspace, or extspace” on page 20-25

reset sysadmin argument: Move the sysadmin database (SQL administration API)

Use the **reset sysadmin** argument with the **admin()** or **task()** function to move the **sysadmin** database to the specified dbspace. Moving the **sysadmin** database resets the database back to the original state when it was first created; all data, **command history**, and results tables are lost. Only built-in tasks, sensors, and thresholds remain in the **sysadmin** tables.

Syntax

```

▶▶ EXECUTE FUNCTION admin task ("reset sysadmin" , "dbspace") ;

```

Element	Description	Key Considerations
<i>dbspace</i>	The name of the dbspace.	

Usage

This function has no equivalent utility command.

If you specify no *dbspace* as the last argument, this command drops the **sysadmin** database, and then recreates it in the same dbspace where it existed before the function was invoked. All **ph_*** table and **command_history** rows are deleted, and all results tables are dropped.

Examples

The following example moves the **sysadmin** database to a dbspace named **dbsp1**:

```
EXECUTE FUNCTION task("reset sysadmin","dbs1");
```

The next example destroys the **sysadmin** database, and then recreates it in the same dbspace.

```
EXECUTE FUNCTION admin("reset sysadmin");
```

Except for the built-in tasks, sensors, and thresholds, all data rows are deleted from the **ph_** tables and all results tables are dropped from **sysadmin** by this function call. The **command_history** table has no rows after the function completes execution.

Related concepts:

Chapter 3, "The sysadmin Database," on page 3-1

restart listen argument: Stop and start a listen thread dynamically (SQL administration API)

Use the **restart listen** argument with the **admin()** or **task()** function to stop and then start an existing listen thread for a SOCTCP or TLITCP network protocol without interrupting existing connections.

Syntax

```
►► EXECUTE FUNCTION admin task ("restart listen",—"server_name"—);►►
```

Element	Description	Key Considerations
<i>server_name</i>	The name of the database server for which you want to stop and restart a listen thread.	

Usage

The definition of the listen thread must exist in the **sqlhosts** file.

If necessary, before you restart a listen thread, revise the **sqlhosts** entry. For example, if a running listen thread is bound to port 7777, you can change the port in the **sqlhosts** file, and then restart the thread.

This function is equivalent to the **onmode -P restart server_name** command.

This function does not update the **sqlhosts** file.

Example

The following command stops and then starts a listen thread for a server named **ids_serv1**:

```
EXECUTE FUNCTION task("restart listen","ids_serv1");
```

Related reference:

“onmode -P: Start, stop, or restart a listen thread dynamically” on page 15-23

“start listen argument: Start a listen thread dynamically (SQL administration API)” on page 22-117

“stop listen argument: Stop a listen thread dynamically (SQL administration API)” on page 22-118

scheduler argument: Stop or start the scheduler (SQL administration API)

Use the **scheduler** argument with the **admin()** or **task()** function to start or stop the scheduler.

Syntax

```
▶▶ EXECUTE FUNCTION admin ("scheduler shutdown") ;
```

task "scheduler start"

Usage

Use the **scheduler shutdown** argument to stop the scheduler and deallocate its resources.

Use the **scheduler start** argument to start the scheduler.

This function has no equivalent utility command.

You can view the status of the scheduler threads with the **onstat -g dbc** command.

Example

The following example starts the scheduler after it has been shut down:

```
EXECUTE FUNCTION task("scheduler start");
```

Related reference:

“**onstat -g dbc** command: Print dbScheduler and dbWorker thread statistics” on page 21-73

scheduler lmm enable argument: Specify automatic low memory management settings (SQL administration API)

Use the **scheduler lmm enable** argument with the **admin()** or **task()** function to start automatic low memory management and to update low memory threshold settings.

Syntax

```
▶▶ EXECUTE FUNCTION admin ("scheduler lmm enable" ,
```

task ,

```
▶▶ LMM START THRESHOLD , "start_threshold_size" ,
```

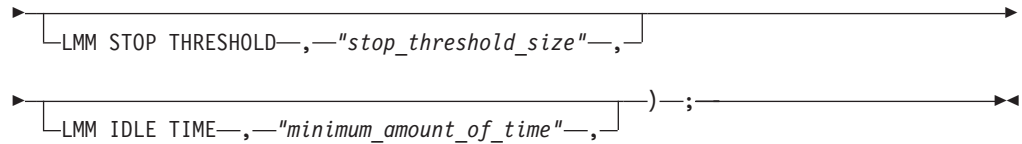

Element	Description	Key Considerations
<i>start_threshold_size</i>	The amount of free memory that you want the database server to maintain. If the amount of memory falls below the <i>start_threshold_size</i> , the server automatically frees memory and terminates applications.	<p>The value can be expressed as either a percentage of the value of the SHMTOTAL configuration parameter or as a specific amount. If the value is less than 50, it is considered a percentage. The resulting value of the input parameter must be more than 5 MB and less than 95 MB.</p> <p>The default value is 5 MB.</p> <p>There must be a minimum 5 MB difference between the LMM START THRESHOLD and LMM STOP THRESHOLD values</p>
<i>stop_threshold_size</i>	The amount of free memory that you want the database server to have, before the server stops automatically freeing memory and terminating applications.	<p>The value can be expressed as either a percentage of the value of the SHMTOTAL configuration parameter or as a specific amount. If the value is less than 50, it is considered a percentage. The resulting value of the input parameter must be more than 10 MB and less than 100 MB. The value must also be at least 5 MB more than the LMM START THRESHOLD.</p> <p>The default value is 10 MB.</p>
<i>minimum_amount_of_time</i>	The amount of time in seconds that defines a session as idle	<p>The value must be between 1 and 86400.</p> <p>The default value is 300 seconds.</p>

Usage

If you enable automatic low memory management and configure the database server to use a percentage of the value specified in the SHMTOTAL configuration parameter for the start and stop thresholds, use caution when changing the value of the SHMTOTAL configuration parameter. Changing the value of the SHMTOTAL configuration parameter value can cause the configuration of automatic low memory management to become invalid, forcing Informix to use the default settings.

You use the **scheduler lmm disable** argument with the **admin()** or **task()** function to stop the current and subsequent low memory management processes.

The database server stores automatic low memory management settings in the **ph_threshold** table.

You can view low memory management settings and recent activity with the **onstat -g lmm** command.

When low memory management is triggered, the database server performs these tasks, in order:

1. The database server terminates sessions starting one at a time from the session with largest amount of idle time and continuing as necessary to the session with smallest amount of idle time that exceeds the amount specified in the LMM IDLE TIME setting. The server stops terminating sessions when the LMM STOP THRESHOLD is reached.
2. The database server terminates sessions starting with the session using the most memory and continuing as necessary to the session using the smallest amount of memory until the LMM STOP THRESHOLD is reached.
3. The database server performs memory reconfiguration by setting the VP_MEMORY_CACHE configuration parameter to 0 and running the **onmode -F** command to free unused shared memory segments.

When the low memory management operations are complete, the low memory manager returns to monitoring mode and restores the memory configuration of the database server by setting the VP_MEMORY_CACHE configuration parameter back to its original value.

Example

The following example specifies that when the database server has 10 MB or less of free memory, the server will start automatic low memory management to stop applications and to free memory. The example also specifies that a session is considered idle if it has not run for 300 seconds, and the example specifies that the server will stop automatic low memory management when the server has 20 MB or more of free memory.

```
EXECUTE FUNCTION task("scheduler lmm enable",  
  "LMM START THRESHOLD", "10MB",  
  "LMM STOP THRESHOLD", "20MB",  
  "LMM IDLE TIME", "300");
```

Example of the SHMTOTAL configuration parameter impacting low memory management threshold settings:

Suppose you set the SHMTOTAL configuration parameter to 1000000 (1000 MB or 1 GB), the LMM START THRESHOLD to 2, and the LMM STOP THRESHOLD to 3. Because any value that is less than 50 is a percentage of the value of SHMTOTAL, the actual LMM START THRESHOLD is 20000 (20 MB) and the actual LMM STOP THRESHOLD is 30000 (30 MB).

The database server begins managing low memory when the remaining free memory is 20 MB or less and stop managing memory when the amount of free memory is 30 MB or greater.

Suppose you decide to change the value of the SHMTOTAL configuration parameter because you know now that you don't need as much memory and you

want memory to be available to the operating system. You set the value of SHMTOTAL to 250000 (250 MB). This changes the actual LMM START THRESHOLD to 5000 (5 MB) and the LMM STOP THRESHOLD to 7500 (7.5 MB). The LMM STOP THRESHOLD is now invalid because there must be a minimum 5 MB difference between the LMM START THRESHOLD and LMM STOP THRESHOLD values. The LMM STOP THRESHOLD value must also be at least 10 MB.

You might have decided that a 10 MB difference is the right amount for your system. But at 5 MB, the database server could spend too much time spent on low memory management processes and this could cause performance problems.

Related concepts:

 Configure the server response when memory is critically low (Administrator's Guide)

Related reference:

“scheduler lmm disable argument: Stop automatic low memory management (SQL administration API)”

“onstat -g lmm command: Print low memory management information” on page 21-111

“LOW_MEMORY_MGR configuration parameter” on page 1-91

“SHMTOTAL configuration parameter” on page 1-137

“VP_MEMORY_CACHE_KB configuration parameter” on page 1-166

scheduler lmm disable argument: Stop automatic low memory management (SQL administration API)

Use the **scheduler lmm disable** argument with the **admin()** or **task()** function to stop the current and subsequent invocations of automatic low memory management.

Syntax

```
▶▶ EXECUTE FUNCTION admin (task ("scheduler lmm disable", -), -);
```

Usage

If automatic low memory management is enabled, you can disable it by specifying:
EXECUTE FUNCTION task("scheduler lmm disable");

You use the **scheduler lmm enable** argument with the **admin()** or **task()** function to start automatic low memory management and update threshold settings.

You can view information about automatic low memory management settings and recent activity with the **onstat -g lmm** command.

Related reference:

“scheduler lmm enable argument: Specify automatic low memory management settings (SQL administration API)” on page 22-102

“onstat -g lmm command: Print low memory management information” on page 21-111

“LOW_MEMORY_MGR configuration parameter” on page 1-91

set chunk argument: Change the status of a chunk (SQL administration API)

Use the **set chunk** argument with the **admin()** or **task()** function to change the status of a blob space, db space, or sb space to online or offline.

Syntax

```

▶▶ EXECUTE FUNCTION admin ("set chunk offline"
task "set chunk online")
▶▶ ,—"space name"—,—"path"—,—"offset"—);

```

Element	Description	Key Considerations
<i>space name</i>	The name of the blob space, db space, or sb space.	
<i>path</i>	The disk partition or unbuffered device of the chunk.	
<i>offset</i>	The offset, in kilobytes, into the disk partition or unbuffered device to reach the chunk.	See “admin() and task() Argument Size Specifications” on page 22-2.

Usage

The chunk must be in a mirrored pair, or a non-primary chunk within a noncritical db space.

Use the **set chunk offline** argument to change the status of the chunk to offline.

Use the **set chunk online** argument to change the status of the chunk to online.

This function is equivalent to the **onspaces -s** command.

Example

The following example changes the status of a chunk to online:

```
EXECUTE FUNCTION task("set chunk online","dbs1","/dev/raw_dev1","0");
Database selected.
```

```
(expression) Chunk status successfully changed.
              Chunk number 2 "/dev/raw_dev1" -- Online
```

1 row(s) retrieved.

Related reference:

“onspaces -s: Change status of a mirrored chunk” on page 20-26

set dataskip argument: Start or stop skipping a dbspace (SQL administration API)

Use the **set dataskip** argument with the **admin()** or **task()** function to specify whether the database server skips a dbspace that is unavailable during the processing of a transaction.

Syntax

```
►► EXECUTE FUNCTION admin ( "set dataskip on" , "dbspace" ) ;  
                  task ( "set dataskip off" ) ;
```

Element	Description	Key Considerations
<i>dbspace</i>	The name of the dbspace to begin or to stop skipping.	

Usage

Run this function to update the value of the DATASKIP configuration parameter, which specifies whether the database server skips a dbspace that is unavailable (for example, due to a media failure) in the course of processing a transaction.

Use the **set dataskip on** argument to begin skipping the specified dbspace when it is down.

Use the **set dataskip off** argument to stop skipping the specified dbspace.

This function is equivalent to the **onspaces -f** command.

Example

The following example skips the dbspace named **dbsp1** if it is down:

```
EXECUTE FUNCTION task("set dataskip on","dbsp1");
```

Related reference:

“onspaces -f: Specify DATASKIP parameter” on page 20-21

“DATASKIP Configuration Parameter” on page 1-42

set index compression argument: Change index page compression (SQL administration API)

Use the **set index compression** argument with the **admin()** or **task()** function to modify the level at which two partially used index pages are merged.

Syntax

```
►► EXECUTE FUNCTION admin ( _____ )  
                  task ( _____ )
```



```
► "set index compression"—,"partition_number"—, (
  "med"
  "default"
  "high"
  "low"
) —; ►
```

Element	Description	Key Considerations
<i>partition_number</i>	The partition number.	Find the partition numbers in the partnum column of the sysables system catalog table.

Usage

Use this function to adjust index page compression. The pages are merged if the data on those pages totals a set level. To optimize space and transaction processing, you can lower the compression level if your indexes grow quickly. You can increase the level if your indexes have few delete and insert operations or if batch updates are performed.

Use the **low** argument if you expect an index to grow quickly with frequent splits.

Use the **med** or **default** argument if an index has moderate growth or changes.

Use the **high** argument if an index is 90 percent or more read-only or does not have many changes.

This function is equivalent to the **onmode -C** command and the **compression** option of the BTSCANNER configuration parameter.

Example

The following example sets index compression for a partition to high:

```
EXECUTE FUNCTION task("set index compression","1048611","high");
```

Related reference:

"onmode -C: Control the B-tree scanner" on page 15-5

set onconfig memory argument: Temporarily change a configuration parameter (SQL administration API)

Use the **set onconfig memory** argument with the **admin()** or **task()** function to dynamically update the value of a configuration parameter in memory.

Syntax

```
►► EXECUTE FUNCTION (
  admin
  task
) —; ►
```

```
► "set onconfig memory"—,"configuration_parameter"—,"value"—) —; ►
```

Element	Description	Key Considerations
<i>configuration_parameter</i>	The name of a configuration parameter.	The configuration parameter must be one that you can update dynamically. The list of configuration parameters that you can update dynamically is the same as for the onmode -wf command.
<i>value</i>	The new value or values for the configuration parameter.	The new value or values must be valid for the configuration parameter. The format of the new value must conform exactly to the syntax for that configuration parameter.

Usage

Use this function to temporarily update the value of a configuration parameter that can be dynamically updated. The new value takes affect immediately. The new value is not written to the **onconfig** file and is lost when the database server is restarted.

This function is equivalent to the **onmode -wm** command.

Example

The following example sets the value of the DYNAMIC_LOGS configuration parameter to 2 for the current session:

```
EXECUTE FUNCTION task("set onconfig memory","DYNAMIC_LOGS","2");
```

Related reference:

“onmode -wf, -wm: Dynamically change certain configuration parameters” on page 15-26

set onconfig permanent argument: Permanently change a configuration parameter (SQL administration API)

Use the **set onconfig permanent** argument with the **admin()** or **task()** function to dynamically update the value of a configuration parameter in the **onconfig** file.

Syntax

```
▶ EXECUTE FUNCTION admin  
task (  )  
▶ "set onconfig permanent"    );
```

Element	Description	Key Considerations
<i>configuration_parameter</i>	The name of a configuration parameter.	The configuration parameter must be one that you can update dynamically. The list of configuration parameters that you can update dynamically is the same as for the onmode -wf command.
<i>value</i>	The new value or values for the configuration parameter.	The new value or values must be valid for the configuration parameter. The format of the new value must conform exactly to the syntax for that configuration parameter.

Usage

Use this function to permanently update the value of a configuration parameter. The new value takes affect immediately and persists in the **onconfig** file after the server restarts.

This function is equivalent to the **onmode -wf** command.

Example

The following example sets the value of the DYNAMIC_LOGS configuration parameter to 2 in the **onconfig** file:

```
EXECUTE FUNCTION task("set onconfig permanent","DYNAMIC_LOGS","2");
```

Related reference:

"onmode -wf, -wm: Dynamically change certain configuration parameters" on page 15-26

set sbspace accesstime argument: Control access time tracking (SQL administration API)

Use the **set sbspace accesstime** argument with the **admin()** or **task()** function to start or stop tracking the time of access for all smart large objects stored in the sbspace.

Syntax

```

▶▶ EXECUTE FUNCTION admin ("set sbspace accesstime off"
task "set sbspace accesstime on")
▶▶ ,—"sbspace"—);

```

Element	Description	Key Considerations
<i>sbspace</i>	The name of the sbspace.	

Usage

Use the **set sbspace accesstime off** argument to turn off tracking of access times.

Use the **set sbspace accesstime on** argument to turn on tracking of access times for all smart large objects stored in the sbspace.

This function is equivalent to the **onspaces -ch** command.

Example

The following example turns off tracking of access times for the sbspace named **sbsp1**:

```
EXECUTE FUNCTION task("set sbspace accesstime off","sbsp1");
```

Related reference:

“onspaces -ch: Change sbspace default specifications” on page 20-17

“create sbspace with accesstime argument: Create an sbspace that tracks access time (SQL administration API)” on page 22-36

set sbspace avg_lo_size argument: Set the average size of smart large objects (SQL administration API)

Use the **set sbspace avg_lo_size** argument with the **admin()** or **task()** function to specify an expected average size of the smart large objects in the specified sbspace so that the database server can calculate the size of the metadata area.

Syntax

```
▶▶ EXECUTE FUNCTION admin ( task ) ( — ) ;  
▶▶ "set sbspace avg_lo_size" — , —"sbspace"— , —"size"— ) ;
```

Element	Description	Key Considerations
<i>sbspace</i>	The name of the sbspace.	
<i>size</i>	The average size, in kilobytes, of the smart large object stored in the sbspace.	Windows: 4 to 2**31 UNIX: 2 to 2**31

Usage

This function is equivalent to the **onspaces -ch** command.

Example

The following example sets the expected average size of smart large objects in the sbspace named **sbsp1** to 8 KB:

```
EXECUTE FUNCTION task("set sbspace avg_lo_size","sbsp1","8");
```

Related reference:

“onspaces -ch: Change sbspace default specifications” on page 20-17

set sbspace logging argument: Change the logging of an sbspace (SQL administration API)

Use the **set sbspace logging** argument with the **admin()** or **task()** function to specify whether the database server logs changes to the user data area of the sbspace.

Syntax

```
▶▶ EXECUTE FUNCTION admin | task ( "set sbspace logging on" | "set sbspace logging off" )  
▶▶ , "sbspace" ) ;
```

Element	Description	Key Considerations
<i>sbspace</i>	The name of the sbspace.	

Usage

Use the **set sbspace logging on** argument to log changes to the user data area of the sbspace.

Use the **set sbspace logging off** argument to not log changes to the user data area of the sbspace.

This function is equivalent to the **onspaces -ch** command.

Example

The following example starts sbspace logging for an sbspace named **sbsp1**:

```
EXECUTE FUNCTION task("set sbspace logging on","sbsp1");
```

Related reference:

“onspaces -ch: Change sbspace default specifications” on page 20-17

set sql tracing argument: Set global SQL tracing (SQL administration API)

Use the **set sql tracing** argument with the **admin()** or **task()** function to set global SQL tracing.

Syntax

```
▶▶ EXECUTE FUNCTION admin | task
```

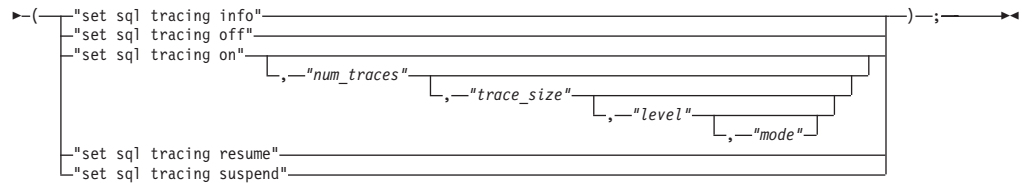

Element	Description	Key Considerations
<i>level</i>	The tracing level. The default is low .	Possible values are: <ul style="list-style-type: none"> • low • med • high
<i>mode</i>	Whether all or selected users are traced.	Possible modes are: <ul style="list-style-type: none"> • global • user
<i>num_traces</i>	The number of SQL statements to trace. The default value is 1000.	
<i>trace_size</i>	The number of kilobytes for the size of the trace buffer. If this buffer size is exceeded, the database server discards saved data. The default size is 2 KB.	

Usage

Use this function to reset the value of the SQLTRACE configuration parameter.

Use the **set sql tracing info** argument to display the state of global SQL tracing.

Use the **set sql tracing off** argument to turn off global SQL tracing.

Use the **set sql tracing on** argument to turn on global SQL tracing. Optionally specify the tracing level and mode:

- Use the **low** argument to capture statement statistics, statement text, and statement iterators.
- Use the **med** argument to capture all of the information included in low-level tracing, plus table names, the database name, and stored procedure stacks.
- Use the **high** argument to capture all of the information included in medium-level tracing, plus host variables.
- Use the **global** argument to enable tracing for all users.
- Use the **user** argument to enable tracing for those users who have tracing enabled by the **set sql tracing user** argument.

Use the **set sql tracing resume** argument to restart SQL tracing when it has been suspended.

Use the **set sql tracing suspend** argument to pause SQL tracing without deallocating any resources.

Example

The following example starts a high level of global tracing for 1500 SQL statements into a 4 KB trace buffer:

```
EXECUTE FUNCTION task("set sql tracing on","1500","4","high","global");
```

The following example pauses SQL tracing:

```
EXECUTE FUNCTION task("set sql tracing suspend");
```

Related reference:

“SQLTRACE Configuration Parameter” on page 1-147

set sql tracing database argument: Change database tracing (SQL administration API)

Use the **set sql tracing database** argument with the **admin()** or **task()** function to start or stop tracing for a database, or list which databases are being traced.

Syntax

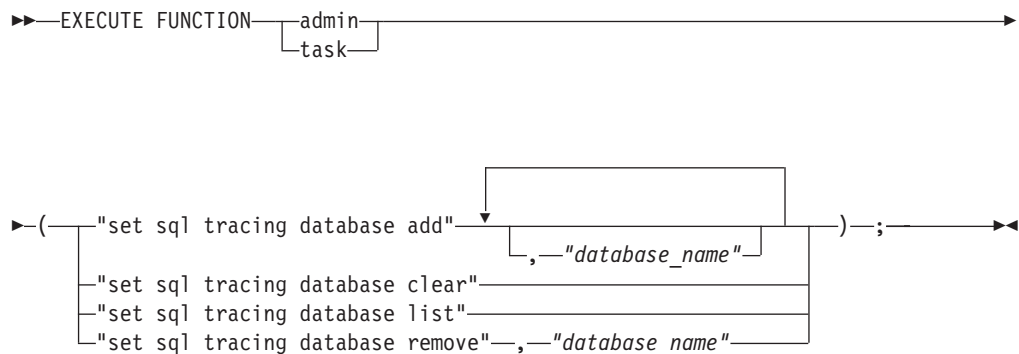

Element	Description	Key Considerations
<i>database_name</i>	The name of the database.	Specify one database name.

Usage

Use the **set sql tracing database add** argument to specify tracing for one or more databases, rather than for all databases. The default is all databases. Specify up to six arguments in a single **admin()** or **task()** function. The maximum number of database names that can be set is 16.

Use the **set sql tracing database clear** argument to clear all databases from the list of databases being traced. Returns tracing back to the default of all databases.

Use the **set sql tracing database list** argument to list the databases that are being traced.

Use the **set sql tracing database remove** argument to remove a single database from the list of databases being traced.

When you use the **set sql tracing database** argument, you can specify only the name of one database. While you can have a maximum of 16 database names, you

must specify each additional database name in separate function calls. Each time you call the function, the function adds another database to the list, until the list contains 16 databases.

Example

The following example sets SQL tracing for three databases with the names **db1**, **db2** and **db3**:

```
EXECUTE FUNCTION task("set sql tracing database add","db1");
EXECUTE FUNCTION task("set sql tracing database add","db2");
EXECUTE FUNCTION task("set sql tracing database add","db3");
```

set sql tracing session argument: Control tracing for a session (SQL administration API)

Use the **set sql tracing session** argument with the **admin()** or **task()** function to change SQL tracing for the current session.

Syntax

```
▶▶ EXECUTE FUNCTION admin
task
▶▶ (—"set sql tracing session"—, "clear"
"off"
"on"
,"current_session_id"
,— "session_id"
▶▶) —;
```

Element	Description	Key Considerations
<i>current_session_id</i>	The ID of the current session. This is the default session ID.	
<i>session_id</i>	The ID of the session to which this command applies.	

Usage

Use the **clear** argument to clear any global tracing overrides. The session will conform to the global tracing policy.

Use the **off** argument to turn off tracing for the session, even if the global tracing policy is set to enable tracing.

Use the **on** argument to turn on tracing for the session, even if the global tracing policy is set to disable tracing.

Example

The following example stops tracing for the current session:

```
EXECUTE FUNCTION task("set sql tracing session","off");
```

set sql tracing user argument: Control tracing for users (SQL administration API)

Use the **set sql tracing user** argument with the **admin()** or **task()** function to change SQL tracing for users.

Syntax

```
▶▶ EXECUTE FUNCTION {admin | task}
▶ ( ("set sql tracing user add" | "set sql tracing user clear" | "set sql tracing user list" | "set sql tracing user remove" | "set sql tracing user remove", "user_name") );
```

Element	Description	Key Considerations
<i>user_name</i>	The name of the user.	

Usage

Use the **set sql tracing user add** argument to specify tracing for a specific user.

Use the **set sql tracing user clear** argument to remove all users from the tracing list.

Use the **set sql tracing user list** argument to list the users that are being traced.

Use the **set sql tracing user remove** argument to remove a single user from the list of users being traced.

Example

The following example stops tracing SQL statements for the user named **fred**:

```
EXECUTE FUNCTION task("set sql tracing user remove","fred");
```

set sql user tracing argument: Set global SQL tracing for a user session (SQL administration API)

Use the **set sql user tracing** argument with the **admin()** or **task()** function to set the mode of global SQL tracing for a specified user session.

Syntax

```
▶▶ EXECUTE FUNCTION {admin | task}
▶ ( ("set sql user tracing clear" | "set sql user tracing off" | "set sql user tracing on", "session_id") );
```

Element	Description	Key Considerations
<i>session_id</i>	The ID for the session.	

Usage

Use the **set sql user tracing clear** to clear user tracing flags for the specified user session so that it adheres to the global tracing policy.

Use the **set sql user tracing off** to disable SQL tracing for a user session even if the global mode is ON.

Use the **set sql user tracing on** to enable user SQL tracing for a user session. Even if the global tracing mode is OFF, SQL statements for this user session are traced.

Example

The following example starts tracing for the session with the ID of 18:

```
EXECUTE FUNCTION task("set sql user tracing on","18");
```

start listen argument: Start a listen thread dynamically (SQL administration API)

Use the **start listen** argument with the **admin()** or **task()** function to start an existing listen thread for a SOCTCP or TLITCP network protocol without interrupting existing connections.

Syntax

```
▶▶ EXECUTE FUNCTION admin (task) ("start listen",—"server_name"—); ▶▶
```

Element	Description	Key Considerations
<i>server_name</i>	The name of the database server for which you want to start a listen thread.	

Usage

The definition of the listen thread must exist in the **sqlhosts** file for the server. If the definition of the listen thread does not exist in the **sqlhosts** file, you must add it before you can start the listen thread dynamically. For information on adding listen threads, see the *IBM Informix Administrator's Guide*.

This function does not update the **sqlhosts** file.

This function is equivalent to the **onmode -P start server_name** command.

Example

The following command starts a new listen thread for a server named **ids_serv2**:

```
EXECUTE FUNCTION task("start listen","ids_serv2");
```

Related reference:

“onmode -P: Start, stop, or restart a listen thread dynamically” on page 15-23

“stop listen argument: Stop a listen thread dynamically (SQL administration API)”

“restart listen argument: Stop and start a listen thread dynamically (SQL administration API)” on page 22-101

start mirroring argument: Starts storage space mirroring (SQL administration API)

Use the **start mirroring** argument with the **admin()** or **task()** function to start mirroring for a specified dbspace, blobspace, or sbspace.

Syntax

```
▶▶ EXECUTE FUNCTION admin (task ("start mirroring",—"space"—); ▶▶
```

Element	Description	Key Considerations
<i>space</i>	The name of the blobspace, dbspace, or sbspace.	

Usage

This function is equivalent to the **onspaces -m** command.

Example

The following example starts mirroring for the dbspace named **dbbsp1**:

```
EXECUTE FUNCTION task("start mirroring","dbbsp1");
```

Related reference:

“onspaces -m: Start mirroring” on page 20-22

stop listen argument: Stop a listen thread dynamically (SQL administration API)

Use the **stop listen** argument with the **admin()** or **task()** function to stop an existing listen thread for a SOCTCP or TLITCP network protocol without interrupting existing connections.

Syntax

```
▶▶ EXECUTE FUNCTION admin (task ("stop listen",—"server_name"—); ▶▶
```

Element	Description	Key Considerations
<i>server_name</i>	The name of the database server for which you want to stop a listen thread.	

Usage

The definition of the listen thread must exist in the **sqlhosts** file.

This function does not update the **sqlhosts** file.

This function is equivalent to the **onmode -P stop server_name** command.

Example

The following command stops a listen thread for a server named **ids_serv3**:

```
EXECUTE FUNCTION task("stop listen","ids_serv3");
```

Related reference:

“onmode -P: Start, stop, or restart a listen thread dynamically” on page 15-23

“start listen argument: Start a listen thread dynamically (SQL administration API)” on page 22-117

“restart listen argument: Stop and start a listen thread dynamically (SQL administration API)” on page 22-101

stop mirroring argument: Stops storage space mirroring (SQL administration API)

Use the **stop mirroring** argument with the **admin()** or **task()** function to stop mirroring for a specified dbspace, blobspace, or sbspace.

Syntax

```
▶▶ EXECUTE FUNCTION admin task ("stop mirroring"—,"space"—); ▶▶
```

Element	Description	Key Considerations
<i>space</i>	The name of the blobspace, dbspace, or sbspace.	

Usage

This function is equivalent to the **onspaces -r** command.

Example

The following example stops mirroring for the dbspace with the name of **dbsp1**:

```
EXECUTE FUNCTION task("stop mirroring","dbsp1");
```

Usage

The server uses entries in the storage pool if necessary to add a new chunk to a storage space.

When you add an entry to the storage pool, you might want some control over how that entry is used. For example, to reduce the number of chunks in an instance, you might want only large chunks of space to be allocated from a particular raw device, and might not want the chunks to be extendable. In this case, configure the chunk size for that storage pool entry to be large.

You can add the following types of entries to the storage pool:

- A fixed-length raw device
- A fixed-length cooked file
- An extendable raw device (for extending the size of a chunk)
- An extendable cooked file (for extending the size of a chunk)
- A directory

A storage pool entry that is a directory is always categorized as extendable, because it does not have a total size. If new chunks are automatically created in the directory, the server marks those chunks as extendable. When you add a storage pool entry that is a directory, you might want a small chunk size, because the server can extend any chunk created in the directory and smaller chunk sizes can reduce the amount of wasted space in the instance.

If a storage pool entry is on a High-Availability Data Replication (HDR) primary server, the same path in the entry must be available on all secondary servers in the HDR cluster.

The default units for sizes and offsets are kilobytes. However, you can specify information in any of the ways shown in the following examples:

- "100000"
- "100000 K"
- "100 MB"
- "100 GB"
- "100 TB"

Examples

Adding a storage pool entry for a directory

The following command adds a directory named `/region2/dbspaces` with a beginning offset of 0, a total size of 0, an initial chunk size of 20 megabytes, and a high priority:

```
DATABASE sysadmin;  
EXECUTE FUNCTION task("storagepool add", "/region2/dbspaces", "0", "0",  
"20000", "1");
```

Adding a storage pool entry for a fixed-length raw device

The following command adds a fixed-length raw device with the path name `/dev/raw/device1` and a total of 500 megabytes of space to the storage pool. The

command specifies a beginning offset of 50 megabytes, a total size of 10 gigabytes, a minimum of 100 megabytes to allocate to a chunk, and a low priority.

```
EXECUTE FUNCTION task("storagepool add", "/dev/rawdevice1", "50 MB",  
"10 GB", "100 MB", "3");
```

Adding a storage pool entry for a fixed-length cooked file

The following command adds a fixed-length cooked file and 1 gigabyte of space to the storage pool. The command specifies a beginning offset of 0, a total size of 1000000 kilobytes, a minimum of 50000 kilobytes to allocate to a chunk, and a medium priority:

```
EXECUTE FUNCTION task("storagepool add", "/ifmx_filesystem/storage/cooked7",  
"0", "1000000", "50000", "2");
```

When adding this entry, the server tries to increase the size of the cooked7 file to 1 gigabyte. If the server cannot increase the size because the file system is full, the server returns an error message and does not add the entry to the storage pool.

Informix uses part of the cooked file initially, but can use more of the device as necessary as spaces fill.

Adding a storage pool entry for an extendable cooked file

The following command adds a cooked file with the path name /ifmx/CHUNKFILES/cooked2. If the server uses this entry, the server creates one chunk with an initial size of 1 GB, and the server automatically marks the chunk as extendable.

```
EXECUTE FUNCTION task("storagepool add", "/ifmx/CHUNKFILES/cooked2",  
"0", "0", "1 GB", "2");
```

Adding a storage pool entry with an environment variable in the path

The following example includes an environment variable in the path. The variable was present in the server environment when the **oninit** command ran.

```
EXECUTE FUNCTION task("storagepool add", "$DBSDIR/chunk1",  
"0", "100000", "20000", "2");
```

Related reference:

“storagepool modify argument: Modify a storage pool entry (SQL administration API)” on page 22-123

“storagepool delete argument: Delete one storage pool entry (SQL administration API)”

“storagepool purge argument: Delete storage pool entries (SQL administration API)” on page 22-125

storagepool delete argument: Delete one storage pool entry (SQL administration API)

Use the **storagepool delete** argument with the **admin()** or **task()** function to delete an entry from the storage pool.

```
►► EXECUTE FUNCTION 

|       |
|-------|
| admin |
| task  |

 ("storagepool delete", ,
```

▶ "entry_id")—; —————▶

Element	Description	Key Considerations
<i>entry_id</i>	The ID of the storage pool entry.	The storagepool table in the sysadmin database contains a column that shows the ID of each entry in the storage pool.

Usage

Delete a storage pool entry if you do not want the server to continue to use the entry when expanding a storage space.

To delete all storage pool entries, storage pool entries that have a status of Full, or storage pool entries that have a status of Error, use the SQL administration API **storagepool purge** command. (The **storagepool** table in the **sysadmin** database contains a column that shows the status of each entry in the storage pool.)

Example

The following command deletes the storage pool entry with an entry id of 13:

```
EXECUTE FUNCTION task("storagepool delete", "13");
```

Related reference:

“storagepool add argument: Add a storage pool entry (SQL administration API)” on page 22-120

“storagepool modify argument: Modify a storage pool entry (SQL administration API)”

“storagepool purge argument: Delete storage pool entries (SQL administration API)” on page 22-125

storagepool modify argument: Modify a storage pool entry (SQL administration API)

Use the **storagepool modify** argument with the **admin()** or **task()** function to modify an entry for a directory, cooked file, or raw device that Informix can use when additional storage space is required.

Syntax

▶ EXECUTE FUNCTION admin
task (—————▶

▶ "storagepool modify"—,—"entry_id"—,—————▶

▶ "new_total_size"—,—"new_chunk_size"—,—"new_priority"—)—; —————▶

Element	Description	Key Considerations
<i>entry_id</i>	The ID of the storage pool entry.	The storagepool table in the sysadmin database contains a column that shows the ID of each entry in the storage pool.

Element	Description	Key Considerations
<i>new_total_size</i>	The new amount of total space available to Informix in this entry. The server can allocate multiple chunks from this amount of space.	Be sure to specify 0 for the total size of a directory. If you specify a value that is not zero for a directory, the SQL administration API command returns an error. If you specify 0 for a file or device, the server allocates one extendable chunk from the entry.
<i>new_chunk_size</i>	The minimum size of a chunk that can be allocated from the device, file, or directory.	The smallest chunk that you can create is 1000 K. Therefore, the minimum chunk size that you can specify is 1000 K. See "admin() and task() Argument Size Specifications" on page 22-2.
<i>new_priority</i>	The priority of the directory, file, or device when the server searches through the storage pool for space. 1 = High priority 2 = Medium priority 3 = Low priority	The server attempts to allocate space from a high-priority entry before it allocates space from a lower priority entry.

Usage

Sometimes you might want to change a storage pool entry. For example, you might want to increase the total size of the storage pool when it runs out of space, or you might want to change the chunk size or the priority. When you change the entry, include the total size, chunk size, and priority even if you do not want to change all of these values.

You cannot modify the path or the beginning offset of a storage pool entry. If you want to change either of those values, you must delete the storage pool entry and add an entry with the new path or beginning offset.

If a storage pool entry is on a High-Availability Data Replication (HDR) primary server, the same path in the entry must be available on all secondary servers in the HDR cluster.

The default units for storage pool sizes and offsets are kilobytes. However, you can specify information in any of the ways shown in the following examples:

- "100000"
- "100000 K"
- "100 MB"
- "100 GB"
- "100 TB"

Examples

The following command changes the total size, chunk size, and priority of the storage pool entry that has an ID of 4 to 10 gigabytes, 10 megabytes, and a medium priority.

```
EXECUTE FUNCTION task("storagepool modify", "4", "10 GB", "10000", "2");
```

Suppose that you add an entry to the storage pool and the entry has a path of (/dev/IDS/chunk2), an offset of 0, a total size of 100 megabytes, a minimum chunk size of 100 megabytes, and a priority of 2. Before Informix allocates any space from this entry, you use **onspaces** to manually add a 50 megabyte chunk with the same path (/dev/IDS/chunk2), and an offset of 50 megabytes. The server only detects the overlap when it attempts to use this entry to automatically create a chunk. At that time, the server marks the entry with an "Error" status and attempts to use another entry to create the chunk.

You can correct the problem by changing the total size of the storage pool entry (for example, for entry 2), to 50 megabytes and by changing the minimum chunk size of the entry to 50 megabytes, as follows:

```
EXECUTE FUNCTION task("storagepool modify", "2", "50 MB", "50 MB", "2");
```

Related reference:

"storagepool add argument: Add a storage pool entry (SQL administration API)" on page 22-120

"storagepool delete argument: Delete one storage pool entry (SQL administration API)" on page 22-122

"storagepool purge argument: Delete storage pool entries (SQL administration API)"

storagepool purge argument: Delete storage pool entries (SQL administration API)

Use the **storagepool purge** argument with the **admin()** or **task()** function to delete all storage pool entries, storage pool entries that have a status of Full, or storage pool entries that have a status of Error.

```
▶▶ EXECUTE FUNCTION 

|       |
|-------|
| admin |
| task  |

 ( 

|                            |
|----------------------------|
| "storagepool purge all"    |
| "storagepool purge full"   |
| "storagepool purge errors" |

 ) ;
```

Usage

Use the **storagepool purge all** argument to delete all entries in the storage pool.

Use the **storagepool purge full** argument to delete all storage pool entries that have a status of Full.

Use the **storagepool purge errors** argument to delete all storage pool entries that have a status of Error.

The **storagepool** table in the **sysadmin** database contains a column that shows the status of each entry in the storage pool.

Example

The following command deletes all storage pool entries that have a status of Full:
EXECUTE FUNCTION task("storagepool purge full");

Related reference:

“storagepool add argument: Add a storage pool entry (SQL administration API)” on page 22-120

“storagepool modify argument: Modify a storage pool entry (SQL administration API)” on page 22-123

“storagepool delete argument: Delete one storage pool entry (SQL administration API)” on page 22-122

Table and fragment compress and uncompress operations (SQL administration API)

You can compress and uncompress the data in a table or in table fragments with SQL administration API **admin()** or **task()** functions and arguments. Compression operations apply only to the contents of data rows and the images of those data rows that appear in logical log records.

The built-in SQL administration API **admin()** or **task()** functions are defined in the **sysadmin** database of each Informix instance. By default, only user **informix** can invoke these functions. If Connect privilege on the **sysadmin** database is granted to user **root** or to **DBSA** group members, they too can invoke the SQL administration API **admin()** or **task()** functions when they are connected directly or remotely to the **sysadmin** database.

The SQL administration API **admin()** or **task()** command arguments that you can use for compress and uncompress operations in tables and table fragments are:

table compression parameters

Performs various compression operations to all fragments of a specified table. For more information, see “table or fragment arguments: Compress data and optimize storage (SQL administration API)” on page 22-127.

fragment compression parameters

Performs various compression operations to a single fragment or a specified set of fragments that belong to a specific table. For more information, see “table or fragment arguments: Compress data and optimize storage (SQL administration API)” on page 22-127.

compression purge_dictionary

Deletes all inactive compression dictionaries or all inactive compression dictionaries that were created before a date that you specify. For more information, see “purge compression dictionary arguments: Remove compression dictionaries (SQL administration API)” on page 22-133.

Table and fragment compression operations include creating compression dictionaries, estimating compression ratios, compressing data in tables and table fragments, consolidating free space (repacking), returning free space to a dbspace (shrinking), uncompressing data, and deleting individual table and fragment compression dictionaries.

An **admin()** command returns an integer; a **task()** command returns a string.

For information on the types of data that you can compress, compression ratios, compression estimates, and compression dictionaries, as well as procedures for using compression command parameters, see *Compression of row data in the IBM Informix Administrator's Guide*. For information on utilities and the **sysmaster** table and view that display compression information, see "syscompdicts_full" on page 2-13.

table or fragment arguments: Compress data and optimize storage (SQL administration API)

Use SQL administration API functions with **table** or **fragment** arguments to create compression dictionaries, estimate compression ratios, compress data in tables and table fragments, consolidate free space (repack), return free space to a dbspace (shrink), uncompress data, and delete compression dictionaries.

Syntax: table data compression command arguments

```

▶▶ EXECUTE FUNCTION admin (task) (table | command arguments | "          ")
▶▶ , "table_name" , "database" , "owner" ) ;

```

Syntax: fragment data compression command arguments

```

▶▶ EXECUTE FUNCTION admin (task) (fragment | command arguments | "          ")
▶▶ , "partnum_list" ) ;

```

Table and fragment command arguments:

create_dictionary	
compress	<u>repack</u> <u>shrink</u>
estimate_compression	
repack	<u>shrink</u>
repack_offline	
shrink	
uncompress	
uncompress_offline	
purge_dictionary	

Command arguments

The following table contains a brief explanation of each argument.

Table 22-20. Arguments for Compress and Uncompress Operations

Argument	Description
create_dictionary	Builds a compression dictionary, which is a library of frequently occurring patterns and the symbol numbers that replace them in compressed rows. After a dictionary is created, any newly inserted or updated rows will be compressed if they are compressible. Existing rows are not compressed.

Table 22-20. Arguments for Compress and Uncompress Operations (continued)

Argument	Description
estimate_compression	Estimates both a new compression ratio and a current ratio. The current ratio is 0.0 percent if the table is not compressed.
compress	Compresses all existing rows in-place, without moving them (without repacking the table). If a compression dictionary for the target table or fragment does not exist, the compress operation also creates the dictionary.
repack	Consolidates free space by moving data to the front of the fragment or table. Because the repack operation moves rows while keeping the fragment online, other queries accessing the fragment that are using an isolation level below Repeatable Read might occasionally find the same row twice or miss finding a row. To avoid this possibility, use the Repeatable Read isolation level for concurrent queries; or, instead of using the repack argument, use the repack_offline argument.
repack_offline	Consolidates free space by moving data to the front of the table or fragment, while holding an exclusive lock on the table or fragment. This operation prevents all other access to data until the operation is completed.
shrink	Returns free space at the end of a fragment or table to the dbspace, thus reducing the total size of the fragment or table.
uncompress	Deactivates compression for new INSERT and UPDATE operations, uncompresses all compressed rows, and deactivates the compression dictionary. This operation also allocates new pages for a fragment and moves uncompressed rows that no longer fit on their original pages to the new pages. Because this operation moves rows while keeping the fragment online, other queries accessing the fragment that are using an isolation level below the Repeatable Read isolation level might occasionally find the same row twice or miss finding a row. To avoid this possibility, use the Repeatable Read isolation level for concurrent queries, or instead of using the uncompress argument, use the uncompress_offline argument.
uncompress_offline	Deactivates compression for new INSERT and UPDATE operations, uncompresses all compressed rows, and deactivates the compression dictionary, while holding an exclusive lock on the fragment. This prevents all other access to the fragment data until the operation is completed. This operation also allocates new pages for a fragment and moves uncompressed rows that no longer fit on their original pages to the new pages.
purge_dictionary	Deletes an inactive compression dictionary, after you uncompress a table or fragment.

Command elements

The following tables show the elements that you can use in commands.

Table 22-21. Table compression and storage optimization command elements

Element	Description	Key Considerations
<i>database</i>	The name of the database that contains the specified table.	Optional. If you do not specify a <i>database</i> , Informix uses the current database. If you enter a database name, you must use the same uppercase or lowercase letters that are in system catalog tables.
<i>owner</i>	The name of the owner of the database that contains the specified table.	Optional. If you do not specify an <i>owner</i> , Informix uses the current owner. If you enter an owner name, you must use the same uppercase or lowercase letters that are in system catalog tables.
<i>table_name</i>	The name of the table that contains the data.	You must use the same uppercase or lowercase letters that are in system catalog tables.

Table 22-22. Fragment compression and storage optimization command elements

Element	Description	Key Considerations
<i>partnum_list</i>	A space-separated list of partition numbers that belong to the same table.	

Usage

Informix uses the compression dictionary to compress data.

After you compress a table or fragment, Informix will automatically compress any new rows that you add to the table or fragment. If the data has changed significantly and you think that the compression dictionary might be built on older data, you should uncompress and then compress again.

You can combine some arguments to perform a combination of operations. Use:

- **compress repack** to perform a combination of compress and repack operations.
- **compress repack shrink** to perform a combination of compress, repack, and shrink operations.
- **compress shrink** to perform a combination of compress and shrink operations.
- **repack shrink** to perform a combination of repack and shrink operations.

You can cancel a command with a **compress** or **uncompress** argument, for example, by typing CTRL-C in DB-Access.

You cannot perform a compress, repack, repack_offline, shrink, uncompress, or uncompress_offline operation on a table or fragment while any of these operations is already occurring on the table or fragment.

You can reissue commands with **repack**, **repack_offline**, **uncompress**, and **uncompress_offline** arguments after a prior interrupted command.

When you perform a combination of operations in a single command, the server runs the operations in this order:

```
create_dictionary compress repack shrink
```

Compress, repack, repack_offline, uncompress, and uncompress_offline operations can consume large amounts of log files. Configure your logs to be larger if any workload that you expect to run, including but not limited to these compression operations, consumes log files faster than one every 30 seconds.

Compress, repack, and uncompress operations are logged, but run in small portions.

If you change the fragmentation strategy for a table after you perform a compression operation, the table loses its compression status and will need to be recompressed.

Dropping or disabling indexes before you complete a repack_offline or uncompress_offline operation can decrease the amount of time that it takes the server to complete the operation. Afterwards, you can re-create or re-enable the indexes, preferably taking advantage of PDQ. Dropping or disabling the indexes and then creating or enabling them again can be faster than completing a repack_offline or uncompress_offline operation without doing this.

Do not drop a dbspace that Change Data Capture (CDC) API is using, if the dbspace ever contained compressed tables, because this might delete compression dictionaries that CDC still needs.

Repack

The compress operation normally creates a quantity of free space on individual data and remainder pages, but the space is not consolidated at the end of the table or fragment. Instead, the space can be used to hold newly inserted rows, with the table not growing any larger until this space has been filled.

A compress operation, which only occurs online, compresses rows of a table in-place. The repack operation moves the rows. You can perform a repack operation online or offline. An online operation allows concurrent activity to occur on a table. However, this can result in *phantom rows*. (Phantom rows are rows that are initially modified or inserted during a transaction that is subsequently rolled back.)

To avoid phantom rows, you might want to repack offline, when you can afford to keep other users from accessing a table or fragment. For example, you could perform a compress operation with concurrent activity during the day, and then perform a repack_offline operation at night, when no concurrent activity is expected on the table.

You cannot perform an offline operation with an online operation. For example, while you can perform a combined compress repack operation, you cannot perform a combined compress repack_offline operation. If you want to repack offline, you must do this in two steps:

1. Perform a compress operation.
2. Perform a repack_offline operation.

Similarly you cannot perform a repack_offline shrink operation.

If light appends (unbuffered, unlogged insert operations) occur in a table or fragment while a repack operation is occurring, the repack operation will not complete the consolidation of space at the end of a table or fragment. The repack operation does not complete because the new extents are added in the location where the repack operation has already occurred, so space cannot be returned to the db space. To complete the repack process, you must run a second repack operation after light append activity has completed. This second repack operation builds on the work of the first repack operation.

Shrink

The shrink operation is usually performed after a repack operation.

You can safely shrink the entire table without compromising the allocation strategy of the table. For example, if you have a fragmented table with one fragment for each day of the week and many fragments pre-allocated for future use, you can shrink the table without compromising this allocation strategy. If the table is empty, Informix shrinks the table to the initial extent size that was specified when the table was created.

When you initiate a shrink operation, Informix shortens extents as follows:

- It shortens all extents except the first extent to as small a size as possible.
- If the table is entirely in the first extent (for example, because the table is an empty table), Informix does not shrink the first extent to a size that was smaller than the extent size that was specified when the table was created with the CREATE TABLE statement.

You can use the MODIFY EXTENT SIZE clause of the ALTER TABLE statement to reduce the current extent size. After you do this, you can rerun the shrink operation to shrink the first extent to the new extent size.

Uncompress

The uncompress operation has no effect on any table or fragment it is applied to that is not compressed.

After you uncompress a table or fragment, you can perform a purge_dictionary operation to delete the dictionary for that table or fragment.

Purge

Before you perform a purge_dictionary operation for tables and fragments, you must:

- Uncompress the tables and fragments.

When you uncompress a table or fragment, Informix marks the dictionary for the table or fragment as inactive.

- Be sure that Enterprise Replication functions do not need the compression dictionaries for older logs.
- Archive any dbspace that contains a table or fragment with a compression dictionary, even if you have uncompressed data in the table or fragment and the dictionary is no longer active.

You can also delete all compression dictionaries or all compression dictionaries that were created before and on a specified date. For information, see “purge compression dictionary arguments: Remove compression dictionaries (SQL administration API)” on page 22-133.

Examples

The following command tells Informix to compress, repack, and shrink both row data in a table named **auto** in the **insurance** database of which **tjones** is the owner and simple large objects in the dbspace.

```
EXECUTE FUNCTION task("table compress repack shrink","auto",  
"insurance","tjones");
```

The following command tells the server to uncompress the fragment with the partition number 14680071.

```
EXECUTE FUNCTION task("fragment uncompress","14680071");
```

The following command tells the server to estimate the benefit of compressing a table named **home** in the **insurance** database of which **fgomez** is the owner.

```
EXECUTE FUNCTION task("table estimate_compression","home",  
"insurance","fgomez");
```

After you run the command, the database server displays an estimate of the compression ratio that can be achieved, along with the currently achieved compression ratio (if it exists). For information about the output of the command, see “Output of the estimate compression operation (SQL administration API).”

Related concepts:

[➔ Data compression \(Administrator's Guide\)](#)

Related reference:

“Output of the estimate compression operation (SQL administration API)”

Output of the estimate compression operation (SQL administration API)

After you run the command for estimating compression ratios, the database server displays information that shows the estimate of the compression ratio that can be achieved, along with the currently achieved compression ratio (if it exists).

Table 22-23. Information that an estimate_compression command displays

Column	Information Displayed
est	This is the estimate of the compression ratio that can be achieved with a new compression dictionary. The estimate is a percentage of space saved compared to no compression.

Table 22-23. Information that an estimate_compression command displays (continued)

Column	Information Displayed
curr	This is the estimate of the currently achieved compression ratio. This estimate is a percentage of space saved compared to no compression. 0.0% will always appear for non-compressed fragments or tables.
change	This is the estimate of the percentage point gain (or possibly loss, although that should be rare) in the compression ratio that you could achieve by switching to a new compression dictionary. This is just the difference between est and curr. If the table or fragment is not compressed, you can create a compression dictionary with the compress parameter. If the fragment is compressed, you must perform an uncompress or uncompress_offline operation, before you can compress.
partnum	This is the partition number of the fragment.
table	This is the full name of the table to which the fragment belongs, in format <i>database.owner.tablename</i>

Example

The following output shows that a .4 percent increase in saved space can occur if you recompress the first fragment. A 75.7 percent increase can occur if you compress the second fragment, which is not compressed.

```

  est  curr  change  partnum  table
-----
 75.7% 75.3% +0.4    0x00200003  insurance:bwilson.disability
 75.7% 0.0% +75.7   0x00300002  insurance:pchang.workcomp

```

Output from compression estimates for tables and fragments look the same, except that the output for a table always shows all fragments in the table, while the output for a fragment only shows information for the specified fragments.

Related reference:

“table or fragment arguments: Compress data and optimize storage (SQL administration API)” on page 22-127

purge compression dictionary arguments: Remove compression dictionaries (SQL administration API)

Call the `admin()` or `task()` function with the `compression purge_dictionary` initial command to delete all inactive compression dictionaries or all inactive compression dictionaries that were created for a compressed table or fragment before a specified date. You must uncompress tables and fragments, which makes the dictionaries inactive, before you delete any compression dictionaries that were created for the tables and fragments.

Syntax: Compression Purge_Dictionary

```

▶▶ EXECUTE FUNCTION admin | task (compression purge_dictionary | date) ;

```

Usage

Before you perform a `purge_dictionary` operation for tables and fragments, you must:

- Uncompress the tables and fragments.
When you uncompress a table or fragment, Informix marks the dictionary for the table or fragment as inactive.
- Be sure that Enterprise Replication functions do not need the compression dictionaries.
- Archive any dbspace that contains a table or fragment with a compression dictionary, even if you have uncompressed data in the table or fragment and the dictionary is no longer active.

The **compression purge_dictionary** command deletes all compression dictionaries.

The **compression purge_dictionary** command with a date as the second argument deletes all compression dictionaries that were created before and on a specified date. You can use any date in a format that can be converted to a DATE data type based on your locale and environment. For example, you can specify 03/29/2009, 03/29/09, or Mar 29, 2009.

You can also delete a specific compression dictionary by calling the **admin()** or **task()** function with **table** or **fragment** as the initial command and **purge_dictionary** as the next argument.

The following command tells Informix to remove all dictionaries that were created before and on July 8, 2009:

```
EXECUTE FUNCTION task("compression purge_dictionary", "07/08/2009");
```

The following command tells Informix to remove the inactive dictionary for a table named **auto** in the **insurance** database of which **tjones** is the owner.

```
EXECUTE FUNCTION task("table purge_dictionary",  
"auto", "insurance", "tjones");
```

Part 4. Appendixes

Appendix A. Files That the Database Server Uses

This appendix provides brief summaries of the files that you use when you configure and use the database server. It also includes descriptions of files (and one directory) created and used internally by the database server. For many of these files, your only responsibilities are to recognize that those files are legitimate and refrain from deleting them.

Pathnames that appear in the following format indicate files that reside on UNIX: **/directory/filename**. Pathnames that appear in the following format indicate files that reside on Windows: **\directory\filename**.

In some cases, environment variables are used to specify the initial pathname of a file. On UNIX, references to environment variables begin with a dollar sign: **\$INFORMIXDIR**. On Windows, references to environment variables begin and end with percent signs: **%INFORMIXDIR%**.

Database server files

The following table contains a list of the database server files and the directories in which they reside.

Table A-1. List of files that the database server uses

Filename	Directory	Purpose	Created
af.xxx	Specified by DUMPPDIR configuration parameter	Assertion-failure information	By the database server
ac_msg.log	/tmp (UNIX) %INFORMIXDIR%\etc (Windows)	archecker message log (for Technical Support)	By the database server
ac_config.std	\$INFORMIXDIR/etc (UNIX) %INFORMIXDIR%\etc (Windows)	Template for archecker-parameter values	By the database server
bar_act.log	/tmp (UNIX) %INFORMIXDIR%\etc (Windows)	ON-Bar activity log	By ON-Bar
bldutil.process_id	/tmp (UNIX) \tmp (Windows)	Error messages about the sysutils database appear in this file	By the database server
buildsmi.out (UNIX) buildsmi_out (Windows)	/tmp (UNIX) %INFORMIXDIR%\etc (Windows) %INFORMIXDIR%\etc\ buildsmi_out. %INFORMIXSERVER %(Windows)	Error messages about SMI database	By the database server

Table A-1. List of files that the database server uses (continued)

Filename	Directory	Purpose	Created
concdr.sh	\$INFORMIXDIR /etc/conv (UNIX) %INFORMIXDIR% \etc\conv (Windows)	Converts the syscdr database to a format for an earlier version of the database server.	By the database server
.conf.dbservername		The onsnmp utility uses this file to obtain the database server configuration	By the database server
core	Directory from which the database server was invoked	Core dump	By the database server
Emergency boot files (For filenames, see “Emergency Boot Files for ON-Bar” on page A-5).	\$INFORMIXDIR/etc (UNIX) %INFORMIXDIR%\etc (Windows)	Used in a cold restore	By ON-Bar
gcore (UNIX)	Specified by DUMPDIR configuration parameter	Assertion failure information	By the database server
illsrta.xx	\$INFORMIXDIR/lib (UNIX) %INFORMIXDIR%\lib (Windows)	Shared libraries for the database server and some utilities	By install procedure
.informix (UNIX)	User's home directory	Set personal environment variables	By the user
informix.rc (UNIX)	\$INFORMIXDIR/etc	Set default environment variables for all users	By the database administrator
INFORMIXTMP	/INFORMIXTMP (UNIX) \%INFORMIXDIR%. (Windows)	Temporary directory for internal files	By the database server
.inf.servicename	/INFORMIXTMP (UNIX) drive:\INFORMIXTMP (Windows)	Connection information	By the database server
.infos.dbservername	\$INFORMIXDIR/etc (UNIX) %INFORMIXDIR%\etc (Windows)	Connection information	By the database server
.infxdirs	/INFORMIXTMP (UNIX) drive:\INFORMIXTMP (Windows)	Database server discovery file that onsnmp uses	By the database server
InstallServer.log (Windows)	C:\temp	Database server installation log	By the database server
ISM catalog	\$INFORMIXDIR/ism (UNIX) %ISMDIR% (Windows)	Records saved backup objects and storage volumes that IBM Informix Storage Manager (ISM) (ISM) uses	By ISM
ISM logs	\$INFORMIXDIR/ism/logs (UNIX) %ISMDIR%\logs (Windows)	Operator alert messages, backend status, additional ISM information	By ISM

Table A-1. List of files that the database server uses (continued)

Filename	Directory	Purpose	Created
ISMversion	\$INFORMIXDIR/ism (UNIX) %ISMDIR% (Windows)	ISM version	During installation
JVM_vpid	Specified by JVPLOG configuration parameter	Messages that the Java virtual machine generates	By the Java virtual machine
JVPLOG	Specified by JVPLOG configuration parameter	Messages from the Java virtual processor	By the database server
.jvpprops	Specified by JVPPROFILE configuration parameter	Template for Java VP properties	During installation
Message log	Specified by MSGPATH configuration parameter	Error messages and status information	By the database server
The ONCONFIG file	\$INFORMIXDIR/etc (UNIX) %INFORMIXDIR%\etc (Windows)	Configuration information	By the database administrator
onconfig	\$INFORMIXDIR/etc (UNIX) %INFORMIXDIR%\etc (Windows)	Default ONCONFIG file (optional)	By the database server administrator
onconfig.std	\$INFORMIXDIR/etc (UNIX)	Template for configuration- parameter values	During installation
oncfg_servername. servernum	\$INFORMIXDIR/etc (UNIX) %INFORMIXDIR%\etc (Windows)	Configuration information for whole-system restores	By the database server
onsnmp.servername	/tmp (UNIX) \tmp (Windows)	Log file that the onsnmp subagent uses	By onsnmp
onsrvapd.log	/tmp (UNIX) \tmp (Windows)	Log file for the database server daemon onsrvapd	By onsnmp
revcdr.sh	\$INFORMIXDIR /etc/conv (UNIX) %INFORMIXDIR% \etc\conv(Windows)	Reverts the syscdr database to an earlier format	By the database server
servicename.exp	/INFORMIXTMP (UNIX) <i>drive</i> :\INFORMIXTMP (Windows)	Connection information	By the database server
servicename.str	/INFORMIXTMP (UNIX) <i>drive</i> :\INFORMIXTMP (Windows)	Connection information	By the database server
shmem.xxx (UNIX)	Specified by DUMPDIR configuration parameter	Assertion-failure information	By the database server
sm_versions.std	\$INFORMIXDIR/etc (UNIX) %INFORMIXDIR%\etc (Windows)	Identifies storage manager in use	During installation

Table A-1. List of files that the database server uses (continued)

Filename	Directory	Purpose	Created
snmpd.log	/tmp (UNIX) \\tmp (Windows)	Log file for the SNMP master agent, snmpdm	By onsnmp
sqlhosts (UNIX)	\$INFORMIXDIR/etc	Connection information; contained in the registry on Windows	During installation; modified by the database server administrator
VP.servername.nnx	/INFORMIXTMP (UNIX) drive:\INFORMIXTMP (Windows)	Connection information	By the database server
xbsa.messages	\$INFORMIXDIR /ism/applogs (UNIX) %ISMDIR%\applogs (Windows)	XBSA library call information	By ON-Bar and the storage manager

Descriptions of Files

This section provides short descriptions of the files listed in Table A-1 on page A-1.

af.xxx

The database server writes information about an assertion failure to the **af.xxx** file. The file is stored in the directory that the DUMPPDIR configuration parameter specifies. For more information, see the information on monitoring for data inconsistency in your *IBM Informix Administrator's Guide*.

ac_msg.log

When you use **archecker** with ON-Bar to verify a backup, it writes brief status and error messages to the ON-Bar activity log and writes detailed status and error messages to the **archecker** message log (**ac_msg.log**). Technical Support uses the **archecker** message log to diagnose problems with backups and restores.

You specify the location of the **archecker** message log with the AC_MSGPATH configuration parameter. For more information, see the *IBM Informix Backup and Restore Guide*.

ac_config.std

The **ac_config.std** file contains the default **archecker** (archive checking) utility parameters. To use the template, copy it into another file, and modify the values. For a comprehensive list of the **archecker** parameters and how to use **archecker** with ON-Bar, see the *IBM Informix Backup and Restore Guide*.

bar_act.log

As ON-Bar backs up and restores data, it writes progress messages, warnings, and error messages to the ON-Bar activity log (**bar_act.log**). You specify the location of the ON-Bar activity log with the BAR_ACT_LOG configuration parameter. For more information, see the *IBM Informix Backup and Restore Guide*.

bldutil.process_id

If the database server cannot build the sysutils database, it creates the **bldutil.<process_id>** file which contains the error messages. The **process_id** value is the process ID of the **bldutil.sh** program. To access this output file, specify **\$(RESFILE)**.

buildsmi.out (UNIX) or buildsmi_out (Windows)

If the database server cannot build the **sysmaster** database, it places a message in the message log that refers you to the output file of the **buildsmi** script, whose filename and pathname are platform-dependent.

On UNIX, the file specification is

/tmp/buildsmi.out

On Windows, the file specification is

%INFORMIXDIR%\etc\buildsmi_out.%INFORMIXSERVER%

Here **%INFORMIXSERVER%** is the name of the Informix instance. This file provides information about why the build failed. For information about the **sysmaster** database, refer to Chapter 2, “The sysmaster Database.”

concdr.sh

To convert the **syscdr** database from 7.31, 9.20, 9.21, 9.3 or 9.4 to 10.0 format, run the **concdr.sh** script on UNIX or the **concdr.bat** script on Windows. For details, see the *IBM Informix Migration Guide*.

.conf.dbservername

The **.conf.dbservername** file is created when you initialize the database server. The **onsnmp** utility queries this file to find out the configuration status of the database server. Do not delete this file.

The **.conf.dbservername** file contains information on shared memory and configuration that allows shared-memory clients to connect to the database server when they use utilities such as **onstat** or **onmode**.

core

The **core** file contains a core dump caused by an assertion failure. The database server writes this file to the directory from which the database server was invoked. For more information on monitoring for data inconsistency, see the chapter on consistency checking in the *IBM Informix Administrator's Guide*.

Emergency Boot Files for ON-Bar

The ON-Bar emergency boot files contain the information needed to perform a cold restore, and are updated after every backup. For details, see the *IBM Informix Backup and Restore Guide*.

The filename for the Informix emergency boot file is **ixbar.servernum**.

gcore.xxx (UNIX)

The database server writes information about an assertion failure to the **gcore.xxx** file. The file is stored in the directory specified by the DUMPPDIR configuration parameter. For more information on monitoring for data inconsistency, see the chapter on consistency checking in the *IBM Informix Administrator's Guide*.

illsrta.xx

The **illsrta.xx** files are shared libraries that the database server and some database server utilities use. The shared libraries, if supported on your platform, are installed in **\$INFORMIXDIR/lib** or **%INFORMIXDIR%\lib**.

The naming convention of the Informix shared library filename is as follows:

illsrta.xx

<i>lll</i>	library class (for example, asf or smd)
<i>s</i>	library subclass (d=DSA; s=standard)
<i>rr</i>	major release number (for example, 07 or 08)
<i>a</i>	library version ID (for example, a or b)
<i>xx</i>	shared-library filename extension (for example, so)

UNIX Only:

Symbolic links to these files are automatically created in **/usr/lib** when the products are installed on your computer. The symbolic links to the shared libraries in **/usr/lib** are automatically created by the product installation procedures. However, if your **\$INFORMIXDIR** is not installed using the standard installation method (for example, your **\$INFORMIXDIR** is NFS-mounted from another computer), you or your system administrator might need to create manually the symbolic links of the shared libraries in **/usr/lib**.

~/.informix

The **~/.informix** file is the *private-environment file*. Users can create this file and store it in their home directory. The *IBM Informix Guide to SQL: Reference* discusses the environment-configuration files.

informix.rc (UNIX)

The **/informix.rc** file is the *environment-configuration file*. You can use it to set environment variables for all users of IBM Informix products. The *IBM Informix Guide to SQL: Reference* discusses the environment-configuration files.

INFORMIXTMP

The **INFORMIXTMP** directory is an *internal database server directory*. During initialization, the database server creates this directory (if it does not exist yet) for storing internal files that must be local and relatively safe from deletion. The **onsnmp** utility uses the files in the **INFORMIXTMP** directory.

.inf.servicename

The database server creates the **.inf.servicename** file if any DBSERVERNAME or DBSERVERALIASES uses a shared-memory connection type. The database server removes the file when you take the database server offline. The name of this file is derived from the servicename field of the **sqlhosts** file or registry.

The database server keeps information about client/server connections in this file. You do not use the **.inf.servicename** file directly. You only need to recognize that it is a legitimate file when it appears in the **INFORMIXTMP** directory.

If this file is accidentally deleted, you must restart the database server.

.infos.dbservername

The database server creates the **.infos.dbservername** file when you initialize shared memory and removes the file when you take the database server offline. This file resides in **\$INFORMIXDIR/etc** or **%INFORMIXDIR%\etc**. The name of this file is derived from the DBSERVERNAME parameter in the ONCONFIG configuration file.

The **.infos.dbservername** file contains information on shared memory and configuration that allows shared-memory clients to connect to the database server when they use utilities such as **onstat** or **onmode**. Do not delete this file.

.infxdirs

The database server maintains an **.infxdirs** file in the **INFORMIXTMP** directory. This file contains a line for every **INFORMIXDIR** from which a database server has been launched. If you remove the **.infxdirs** file, **on snmp** cannot discover any database servers until the next time you restart the database server. Each time you restart the database server, it re-creates the **.infxdirs** file.

InstallServer.log (Windows)

The database server creates the **InstallServer.log** during installation.

ISM catalog

IBM Informix Storage Manager (ISM) creates the ISM catalog during the **ism_startup** initialization. The ISM catalog records information about backup and restore save sets and about storage volumes that the storage manager uses.

The ISM catalog records are stored in the **mm**, **index**, and **res** files in the **\$INFORMIXDIR/ism** or **%ISMDIR%\ism** directory. For more information, see the *IBM Informix Storage Manager Administrator's Guide*.

ISM logs

IBM Informix Storage Manager (ISM) creates several logs during ON-Bar backup and restore operations.

ISM The message window in the ISM Administrator GUI displays messages from these logs.

Log	Description
------------	--------------------

daemon.log
ISM backend status

messages
Operator alert messages

summary
Additional ISM information

For more information, see the *IBM Informix Storage Manager Administrator's Guide*.

ISMversion file

The **ISMversion** file, which is installed with the database server, identifies the IBM Informix Storage Manager (ISM) version. Do not edit this file

JVM_vpid file

The **JVM_vpid** file is a log file, where **vp_id** is the process ID of the Java virtual processor. For more information, see the *J/Foundation Developer's Guide*.

JVPLOG

When **JVPDEBUG** is set to 1, the database server writes tracing messages to the **JVPLOG** file. You can adjust the tracing level. On UNIX, you can have multiple **JVPLOG** files, one for each JVP virtual processor. On Windows, only one **JVPLOG** file exists. To obtain the JVP IDs, use the **onstat -g glo** command. For more information, see *J/Foundation Developer's Guide*.

.jvpprops

The **.jvpprops** file sets the Java virtual processor properties. Copy the **.jvpprops.template** to a new file named **.jvpprops**, and modify the values. For more information, see *J/Foundation Developer's Guide*.

Message Log

The database server writes status and error information to the message-log file. You specify the filename and location of the message log with the **MSGPATH** configuration parameter. For more information, refer to "MSGPATH configuration parameter" on page 1-100.

onconfig.std

The **onconfig.std** file serves as the template for creating the **ONCONFIG** configuration file. To use the template, copy it to another file and modify the values.

Important: Do not modify or delete the **onconfig.std** file. If you omit a parameter value in your copy of the configuration file, the database server either uses default values in **onconfig.std** template file or calculates values based on other parameter values.

Related reference:

“onconfig Portal: Configuration parameters by functional category” on page 1-3

The ONCONFIG File

The *current configuration file* is the `%INFORMIXDIR%\etc\%ONCONFIG%` or `$INFORMIXDIR/etc/$ONCONFIG` file. The database server uses the ONCONFIG file during initialization.

If you start the database server with `oninit` and do not explicitly set the `ONCONFIG` environment variable, the database server looks for configuration values in the `onconfig.std` file. If no `onconfig.std` file exists, the database server returns the following error message:

```
WARNING: Cannot access configuration file $INFORMIXDIR/etc/$ONCONFIG.
```

For more information on the order of files where the database server looks for configuration values during initialization, refer the material on initializing the database server in the *IBM Informix Administrator's Guide*.

For more information on setting up your ONCONFIG file, refer to the materials on installing and configuring the database server in the *IBM Informix Administrator's Guide*.

onconfig

The `onconfig` file is an optional file that you create in the `$INFORMIXDIR/etc` or `%INFORMIXDIR%\etc` directory. The `onconfig` file is the default configuration file if the `ONCONFIG` environment variable is not set. For more information, refer to processing the configuration file in the *IBM Informix Administrator's Guide*.

To create the `onconfig` file, you can copy `onconfig.std` or one of your customized configuration files. For more information on setting up your `ONCONFIG` file, refer to installing and configuring the database server in the *IBM Informix Administrator's Guide*.

oncfg_servername.servernum

The database server creates the `oncfg_servername.servernum` file in the `$INFORMIXDIR/etc` or `%INFORMIXDIR%\etc` directory when you initialize disk space. The database server updates the file every time that you add or delete a `dbspace`, a logical-log file, or a chunk. The database server uses the `oncfg_servername.servernum` file when it salvages logical-log files during a whole-system restore. The database server derives the name of this file from the values of the `DBSERVERNAME` and `SERVERNUM` parameters in the ONCONFIG configuration file.

The database server uses the `oncfg_servername.servernum` files, so do not delete them. For more information, refer to creating the `oncfg_servername.servernum` file in the *IBM Informix Administrator's Guide* and the *IBM Informix Backup and Restore Guide*.

onsnmp.servername

The **onsnmp** subagent uses this log file. For more information, see the *IBM Informix SNMP Subagent Guide*.

This log file is called **onsnmp.servername** on Informix.

onsrvapd.log

The **onsrvapd** daemon uses this log file. For more information, see the *IBM Informix SNMP Subagent Guide*.

revcdr.sh

To revert the **syscdr** database from 10.0 to 9.4, 9.3, 7.31, 9.20, or 9.21 format, run the **revcdr.sh** script on UNIX or the **revcdr.bat** script on Windows. For details, see the *IBM Informix Migration Guide*.

shmem.xxx (UNIX)

The database server writes information about an assertion failure to the **shmem.xxx** file. The file is stored in the directory that the **DUMPDIR** configuration parameter specifies. For more information on monitoring for data inconsistency, see the chapter on consistency checking in the *IBM Informix Administrator's Guide*.

sm_versions.std

The **sm_versions.std** file, which is a template for the **sm_versions** file that you create, contains some data and a line identifying the current version of some storage managers.

To update the storage-manager version, edit the **sm_versions** file and then run the **ism_startup** command. For more information, see the *IBM Informix Backup and Restore Guide*.

snmpd.log

The SNMP master agent, **snmpdm** uses this log file. For more information, see the *IBM Informix SNMP Subagent Guide*.

sqlhosts

UNIX Only:

The **sqlhosts** file is the *connectivity file* on UNIX platforms. It contains information that lets an IBM Informix client connect to an IBM Informix database server. For more information on the **sqlhosts** file, see client/server communications in the *IBM Informix Administrator's Guide*.

Windows Only:

On Windows, the connectivity information is in the **HKEY_LOCAL_MACHINE\SOFTWARE\INFORMIX\SQLHOSTS** key in the Windows registry.

VP.servername.nnx

The database server creates the **VP.servername.nnx** file, if needed, when you initialize shared memory. The name of this file comes from DBSERVERNAME or DBSERVERALIASES in the ONCONFIG file, the VP number (**nn**), and an internal identifier (**x**).

The database server keeps information about client/server connections in the **VP.servername.nnx** file. You do not use the file directly. You only need to recognize that it is a legitimate file.

If this file is accidentally deleted, you must restart the database server.

xbsa.messages

The **xbsa.messages** log contains XBSA library call information.

ON-Bar and ISM use XBSA to communicate with each other.

Technical Support can use the **xbsa.messages** log to diagnose problems with ON-Bar and storage manager communications.

Appendix B. Troubleshooting errors

Occasionally, a series of events causes the database server to return unexpected error codes.

You can use the following diagnostic tools to gather information for troubleshooting errors:

- **onmode -I**
- tracepoints
- The **ifxcollect** tool

Collecting Diagnostics using onmode -I

To help collect additional diagnostics, you can use **onmode -I** to instruct the database server to perform the diagnostics collection procedures that the *IBM Informix Administrator's Guide* describes. To use **onmode -I** when you encounter an error number, supply the *iserrno* and an optional session ID. For more information about **onmode**, see Chapter 15, "The onmode utility," on page 15-1.

Creating Tracepoints

Tracepoints are useful in debugging user-defined routines written in C. You can create a user-defined tracepoint to send special information about the current execution state of a user-defined routine.

Each tracepoint has the following parts:

- A *trace* groups related tracepoints together so that they can be turned on or off at the same time.

You can either use the built-in trace called **_myErrors** or create your own. To create your own trace, you insert rows into the **systracees** system catalog table.

- A *trace message* is the text that the database server sends to the tracing-output file.

You can store internationalized trace messages in the **systracemsgs** system catalog table.

- A *tracepoint threshold* determines when the tracepoint executes.

By default, the database server puts all trace messages in the trace-output file in the **tmp** directory with the following filename:

```
session_num.trc
```

For more information on tracing user-defined routines, see the *IBM Informix DataBlade API Programmer's Guide*.

Collecting data with the ifxcollect tool

You can use the **ifxcollect** tool to collect diagnostic data if necessary for troubleshooting a specific problem, such as an assertion failure. You can also specify options for transmitting the collected data via the File Transfer Protocol (FTP).

The `ifxcollect` tool resides in the `$INFORMIXDIR/bin` directory. Output files that `ifxcollect` commands generate reside in the `$INFORMIXDIR/isa/data` directory.

Syntax

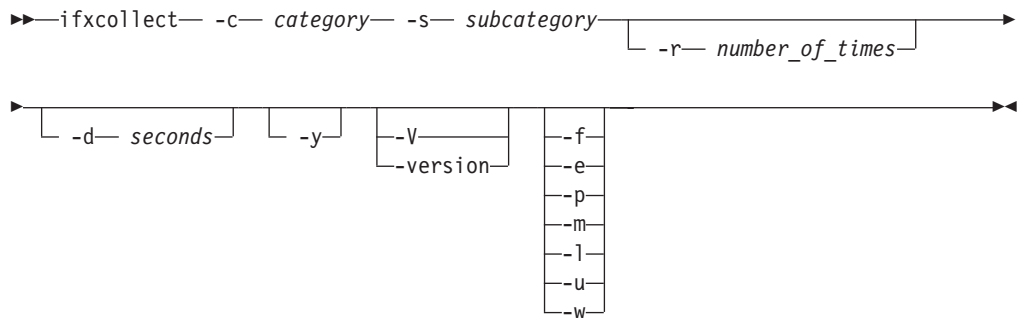

Table B-1. Options for data collection

Element	Description	Key Considerations
<code>-c category</code>	Tells the server to collect data in the specified category.	You must specify the category of data to collect.
<code>-s category</code>	Tells the server to collect data in the specified subcategory.	You must specify the subcategory of data to collect.
<code>-r number of times</code>	Specifies the number of times to repeat data collection	Optional.
<code>-d number of seconds</code>	Specifies the number of times to pause between collection operations	Optional.
<code>-y</code>	Causes the database server to automatically respond yes to all prompts.	Optional.
<code>-V</code>	Displays the software version number and the serial number	Optional. See "Obtaining Utility Version Information" on page 6-1
<code>-version</code>	Displays the build version, host, OS, number and date, as well as the GLS version	Optional. See "Obtaining Utility Version Information" on page 6-1

Table B-2. FTP options if you also transmitting data

Element	Description	Key Considerations
<code>-f</code>	FTP the entire collection	Required for the transmission of data.
<code>-e email address</code>	E-mail address	Required for the transmission of data.
<code>-p the PMR number</code>	PMR number	Required for the transmission of data.
<code>-m machine name</code>	Machine to connect to	Required for the transmission of data.
<code>-l directory</code>	Directory that contains the data	Required for the transmission of data.

Table B-2. FTP options if you also transmitting data (continued)

Element	Description	Key Considerations
-u <i>user name</i>	User name for the FTP	Required for the transmission of data.
-w <i>password</i>	Password for the FTP	Required for the transmission of data.

Usage

The following table shows the combination of categories and subcategories that you can use in your commands.

Table B-3. Category and subcategory combinations

Category and subcategory	Explanation
-c <i>ids -s general</i>	Collects general data for issues related to all Informix products
-c <i>af -s general</i>	Collects general data for assertion failures
-c <i>er -s general</i>	Collects general data for Enterprise Replication
-c <i>er -s init</i>	Collects general data for Enterprise Replication initialization issues
-c <i>performance -s general</i>	Collects data for performance issues
-c <i>performance -s cpu</i>	Collects data for CPU utilization issues
-c <i>onbar -s archive_failure</i>	Collects data for onbar archive failures
-c <i>onbar -s restore_failure</i>	Collects data for onbar restore failures
-c <i>ontape -s archive_failure</i>	Collects data for ontape archive failures
-c <i>ontape -s restore_failure</i>	Collects data for ontape restore failures
-c <i>connection -s failure</i>	Collects data for connection failures
-c <i>connection -s hang</i>	Collects data for connection hangs
-c <i>cust -s prof</i>	Collects customer profile information

To view all **ifxcollect** utility command options, type **ifxcollect** at the command prompt.

Examples

To collect information for a general assertion failure, run this command:

```
ifxcollect -c af -s general
```

To collect information for a performance problem related to CPU utilization, run this command:

```
ifxcollect -c performance -s cpu
```

To include FTP information, specify the additional information as shown in this example:

```
-f -e user_name@company_name.org -p 9999.999.999  
-f -m machine -l /tmp -u user_name -w password
```

Appendix C. Event Alarms

The database server provides a mechanism for automatically triggering administrative actions based on an event that occurs in the database server environment. This mechanism is the event-alarm feature. Events can be informative (for example, Backup Complete) or can indicate an error condition that requires your attention (for example, Unable to Allocate Memory).

Related reference:

“ALARMPROGRAM configuration parameter” on page 1-26

“ALRM_ALL_EVENTS configuration parameter” on page 1-28

Using ALARMPROGRAM to Capture Events

On UNIX, use the `alarmprogram.sh` and on Windows, use the `alarmprogram.bat` shell script, for handling event alarms and starting automatic log backups. For the setup instructions, see “ALARMPROGRAM configuration parameter” on page 1-26.

To automate logical-log backups only, two ready-made scripts are provided: `log_full.[sh | bat]` and `no_log.[sh | bat]`. Set ALARMPROGRAM to the full path name of the script. For information, see “ALARMPROGRAM configuration parameter” on page 1-26.

Setting ALRM_ALL_EVENTS

You can set ALRM_ALL_EVENTS to specify whether ALARMPROGRAM runs for all events that are logged in the MSGPATH or only specified noteworthy events (events greater than severity 1).

Writing Your Own Alarm Script

Alternatively, you can write your own shell script, batch file, or binary program that contains the event-alarm parameters. When an event occurs, the database server invokes this executable file and passes it the event-alarm parameters (see Table C-1 on page C-4). For example, your script can use the `_id` and `_msg` parameters to take administrative action when a table failure occurs. Set ALARMPROGRAM to the full pathname of this executable file.

Related reference:

“ALARMPROGRAM configuration parameter” on page 1-26

Customizing the ALARMPROGRAM Scripts

Follow these steps to customize the `alarmprogram.[sh | bat]` script. You can use `alarmprogram.[sh | bat]` instead of `log_full.[sh | bat]` to automate log backups.

To customize the ALARMPROGRAM scripts:

1. Change the value of ADMINMAIL to the email address of the database server administrator.
2. Change the value of PAGERMAIL to the pager service email address.

3. Set the value of the parameter MAILUTILITY with `/usr/bin/mail` for UNIX and `$INFORMIXDIR/bin/ntmail.exe` for Windows.
4. To automatically back up logical logs as they fill, change BACKUP to `yes`. To stop automatic log backups, change BACKUP to any value other than `yes`.
5. In the ONCONFIG file, set ALARMPROGRAM to the full pathname of `alarmprogram.[sh|bat]`.
6. Restart the database server.

Alarms with a severity of 1 or 2 do not write any messages to the message log nor send email. Alarms with severity of 3 or greater send email to the database administrator. Alarms with severity of 4 and 5 also notify a pager via email.

Related reference:

“ALARMPROGRAM configuration parameter” on page 1-26

Precautions for Foreground Operations in Alarm Scripts

To ensure continuous server availability, do not run certain foreground operations in an alarm script.

When the server invokes an alarm script, the server sometimes waits for the script to complete before proceeding. For example:

- When an alarm is invoked because of a fatal error, the server waits for the script to finish writing information to the error log. In certain situations, alarm events 5 and 6 are run in the foreground.
- Some Enterprise Replication event alarms run in the foreground, such as event alarms 31, 34, 37, and 39.

Because the server might need to wait for the alarm program script to finish, do not run the following operations in the foreground in an alarm script:

- An onmode command that forces user connections off the server such as `onmode -u` or `onmode -yuk`. These kinds of onmode commands can cause a deadlock between the server and the alarm script because the server might wait for the alarm script to complete while the alarm script that executed the onmode command waits for the user sessions to shut down, and one of those sessions is running the alarm script itself.
- Operations that might take a long time to complete or that have a highly variable run time. Operations that take a long time to complete can cause the server to appear as if it is not responding while the operation is running.

If you need to run the above operations in an alarm script, run them in the background using one of the following operating system utilities:

On UNIX: Use the `nohup` utility. For example, `nohup onmode -yuk &` instructs `nohup` to continue running the command even if its parent terminates and the ampersand, `&`, runs the command in the background so it will not block execution of the alarm program script itself.

On Windows: Use the `start` utility with the `/B` flag. For example, `start /B onmode -yuk`.

Interpreting event alarm messages

Some of the events that the database server reports to the message log cause it to invoke the alarm program. The class messages indicate the events that the database server reports.

The database server reports a nonzero exit code in the message log. In the alarm program, set the EXIT_STATUS variable to 0 for successful completion and to another number for a failure.

For example, if a thread attempts to acquire a lock, but the maximum number of locks that LOCKS specifies has already been reached, the database server writes the following message to the message log:

```
10:37:22 Checkpoint Completed: duration was 0 seconds.
10:51:08 Lock table overflow - user id 30032, rstcb 10132264
10:51:10 Lock table overflow - user id 30032, rstcb 10132264
10:51:12 Checkpoint Completed: duration was 1 seconds.
```

When the database server invokes the **alarmprogram.[sh | bat]** program or your alarm program, the database server generates a message that describes the severity and class of the event. If the severity is greater than 2, the message takes the following format:

Action	Message
A reasonably severe server event	Severity: 3 Class ID: 21 Class msg: Database server resource overflow: 'Locks'. Specific msg: Lock table overflow - user id 30032, rstcb 10132264 See Also: # optional message Event ID: 21005
The message that appears at the end of each e-mailed message	This e-mail was generated by the server ALARMPROGRAM script on <i>servername</i> because something untoward just happened to <i>eventname</i> .

Events in the ph_alert Table

All event alarms that are generated are inserted in the **ph_alert** table in the **sysadmin** database.

You can query the **ph_alert** table on local or remote server to view the recent event alarms for that server. You can write SQL scripts based on the **ph_alert** table to handle event alarms instead of using the scripts controlled by the ALARMPROGRAM configuration parameter.

By default, alerts remain in the **ph_alert** table for 15 days before being purged.

Example

The following example shows an event alarm in the **ph_alert** table:

```
SELECT * FROM ph_alerts WHERE alert_object_type=ALARM;
```

```
id                34
alert_task_id     18
alert_task_seq    10
alert_type        INFO
alert_color       YELLOW
alert_time        2010-03-08 12:05:48
alert_state       NEW
alert_state_chang+ 2010-03-08 12:05:48
alert_object_type ALARM
alert_object_name 23
```



```

alert_message      Logical Log 12 Complete, timestamp: 0x8e6a1.
alert_action_dbs   sysadmin
alert_action
alert_object_info  23001

```

Related reference:

“The ph_alert Table” on page 3-5
“Event Alarm Parameters”

Event Alarm Parameters

Event alarms have five parameters that describe each event.

The following table lists the parameters that are part of event alarm.

Table C-1. Event Alarm Parameters

Parameter	Description	Data Type
severity	The severity of the event.	integer
class_id	A numeric identifier that classifies the type of event that has occurred.	integer
class_msg	A brief messages that describes the classification of the event.	string
specific_msg	Specific messages that describes the event that occurred.	string
see_also	A reference to a file that contains additional information about the event.	string
uniqueid	A unique event identifier for the specific message.	bigint

Event Severity

An event severity code is a numeric indication of the seriousness of an event. Every event that is included in the message log contains a severity code. The event severity code is the first parameter that is sent to the alarm program. In the **ph_alert** table, the event severity is reflected by a combination of the alert color and the alert type. The event severity codes are listed in the following table.

Table C-2. Event Severity Codes

Severity	Description
1	Not noteworthy. The event (for example, date change in the message log) is not reported to the alarm program unless ALRM_ALL_EVENTS configuration parameter is enabled. In the ph_alert table, the alert color is GREEN and the alert type is INFO.
2	Information. No error has occurred, but some routine event completed successfully (for example, checkpoint or log backup completed). In the ph_alert table, the alert color is YELLOW and the alert type is INFO.
3	Attention. This event does not compromise data or prevent the use of the system; however, the event warrants your attention. For example, one chunk of a mirrored pair goes down. An email is sent to the system administrator. In the ph_alert table, the alert color is YELLOW and the alert type is WARNING.

Table C-2. Event Severity Codes (continued)

Severity	Description
4	<p>Emergency. Something unexpected occurred that might compromise data or access to data. For example an assertion failure, or oncheck reports data corrupt. Take action immediately. The system administrator is paged when this event severity occurs.</p> <p>In the ph_alert table, the alert color is RED and the alert type is ERROR.</p>
5	<p>Fatal. Something unexpected occurred and caused the database server to fail. The system administrator is paged when this event severity occurs.</p> <p>In the ph_alert table, the alert color is RED and the alert type is ERROR.</p>

Class ID

The class ID is an integer that identifies the event that causes the database server to run your alarm program. The class ID is the second parameter that the database server displays in your alarm program.

The class ID is stored in the **alert_object_name** column in the **ph_alert** table.

Class Message

The class message is a text message briefly describes, or classifies, the event that causes the database server to run your alarm program. The class messages is the third parameter that the database server displays in your alarm program.

Specific Message

The specific message is a text messages the describes in more detail the event that causes the database server to run your alarm program. The specific message is the fourth parameter that the database server displays in your alarm program. For many alarms, the text of this message is the same as the message that is written to the message log for the event.

The specific message is stored in the **alert_message** column in the **ph_alert** table.

See Also Paths

For some events, the database server writes additional information to a file when the event occurs. The path name in this context refers to the path name of the file where the database server writes the additional information.

Event ID

The event ID is a unique number for each specific message. You can use the event ID in custom alarm handling scripts to create responses to specific events.

The event ID is stored in the **alert_object_info** column in the **ph_alert** table.

Related concepts:

“Events in the ph_alert Table” on page C-3

Related reference:

“SHMVIRT_ALLOCSEG configuration parameter” on page 1-138

Event alarm IDs

The class ID for event alarms indicates the type of event. The event ID indicates the specific event.

The following table lists event alarm IDs and messages or where to find more information. Many alarms have additional explanations and user actions. Many of the issues that trigger event alarms also result in messages in the online message log. The location of the message log is specified by the MSGPATH configuration parameter.

Table C-3. Event Alarms

ID	Severity	Messages	Explanation
Class ID: 1 Event ID: 1001	3	Class message: Table failure: 'dbname:"owner".tablename' Specific message: Page allocation error on 'object'	The database server detected an inconsistency during the allocation of pages to a table or index. Online log: Assertion Failure or Assertion Warning with problem details. Server state: Dependent upon the nature of the problem found. User action: Review the online.log file for appropriate action. You will need to run the oncheck utility on the 'dbname:"owner".tablename' identified in the message. Occasionally, the database server automatically resolves the problem, and this resolution is identified in the online.log file.
Class ID: 1 Event ID: 1002	3	Class message: Table failure: 'dbname:"owner".tablename' Specific message: Row allocation error on 'object'	The database server detected an inconsistency during the allocation of a row to a table or index. Online log: Assertion Failure or Assertion Warning with problem details. Server state: Dependent upon the nature of the problem found. User action: Review the online.log file for appropriate action. You will need to run the oncheck utility on the 'dbname:"owner".tablename' identified in the message. Occasionally, the database server automatically resolves the problem, and this resolution is identified in the online.log file.

Table C-3. Event Alarms (continued)

ID	Severity	Messages	Explanation
Class ID: 1 Event ID: 1003	3	Class message: Table failure: ' <i>dbname:"owner".tablename</i> ' Specific message: Slot allocation error for ' <i>object</i> '	The database server detected an inconsistency during row processing. Online log: Assertion Failure or Assertion Warning with problem details. Server state: Dependent upon the nature of the problem found. User action: Review the online.log file for appropriate action. You will need to run the oncheck utility on the ' <i>dbname:"owner".tablename</i> ' identified in the message. Occasionally, the database server automatically resolves the problem, and this resolution is identified in the online.log file.
Class ID: 1 Event ID: 1004	3	Class message: Table failure: ' <i>dbname:"owner".tablename</i> ' Specific message: An internal error prevented the database server to find the next possible data page in this tblspace.	The database server detected an inconsistency in a bitmap page during the allocation of a row to a table or index. Online log: Assertion Failure or Assertion Warning with problem details. Server state: Dependent upon the nature of the problem found. User action: Review the online.log file for appropriate action. Run the oncheck utility on the ' <i>dbname:"owner".tablename</i> ' identified in the message.
Class ID: 1 Event ID: 1005	3	Class message: Table failure: ' <i>dbname:"owner".tablename</i> ' Specific message: Dropping wrong TBLSpace, requested <i>tblspace_name</i> != actual <i>tblspace_name</i>	The database server detected a mismatch between the requested and existing tables while attempting to drop a table. No table was dropped. Online log: Assertion Failure or Assertion Warning with problem details. Server state: Online User action: Review the online.log file for appropriate action. Run the oncheck utility on the ' <i>dbname:"owner".tablename</i> ' identified in the message.
Class ID: 1 Event ID: 1006	3	Class message: Table failure: ' <i>dbname:"owner".tablename</i> ' Specific message: An internal error which may have been caused due to data corruption prevented the database server from altering the bitmap pages for this partition.	The database server encountered a possible data corruption error during a table or index operation to alter bitmap pages. Online log: Assertion Failure or Assertion Warning with problem details. Server state: Online User action: Review the online.log file for appropriate action. Run the oncheck utility on the ' <i>dbname:"owner".tablename</i> ' identified in the message.

Table C-3. Event Alarms (continued)

ID	Severity	Messages	Explanation
Class ID: 1 Event ID: 1007	3	Class message: Table failure: 'dbname:"owner".tablename' Specific message: [3] An internal error which may have been caused due to corrupted bitmap pages as the database server is still in the process of converting them.	The database server encountered an incomplete modification of internal bitmap pages during a table or index operation to alter bitmap pages. Online log: Assertion Failure or Assertion Warning with problem details. Server state: Online User action: Note all circumstances and contact IBM Software Support.
Class ID: 1 Event ID: 1008	3	Class message: Table failure: 'dbname:"owner".tablename' Specific message: An internal error which may have been caused due to unconverted bitmap pages.	The database server encountered a situation where the modification of the internal bitmap pages has not yet completed. during a table or index operation to alter bitmap pages. Online log: Assertion Failure or Assertion Warning with problem details. Server state: Online. User action: Note all circumstances and contact IBM Software Support.
Class ID: 1 Event ID: 1009	4	Class message: Table failure: 'dbname:"owner".tablename' Specific message: Page Check Error in <i>object</i>	The database server detected inconsistencies while checking a page that was being read into internal buffers. Online log: Assertion failure or assertion warning with a description of the problem. Server state: Online or offline, depending on how serious the problem is. User action: Follow the suggestions in the online log. Typically, run the oncheck -cD command on the table mentioned in the class message or on the database.
Class ID: 1 Event ID: 1010	4	Class message: Table failure: 'dbname:"owner".tablename' Specific message: Bad rowid <i>rowid</i>	The database server detected an invalid row ID. Online log: Assertion warning with a description of where the problem was found. Server state: Online. User action: Repair the index by running the oncheck -cI command on the table mentioned in the class message or on the database.

Table C-3. Event Alarms (continued)

ID	Severity	Messages	Explanation
Class ID: 3 1 Event ID: 1011	3	Class message: Table failure: 'dbname:"owner".tablename' Specific message: Closing TBLSpace <i>tblspace_name</i>	The database server determined that the table or index is closed. Online log: Assertion Failure or Assertion Warning with problem details. Server state: Online. User action: None. The database server will correct the problem automatically.
Class ID: 3 1 Event ID: 1012	3	Class message: Table failure: 'dbname:"owner".tablename' Specific message: Cannot recreate index <i>index_name</i> for partnum <i>partition_number</i> , iserrno = <i>error_number</i>	The database server encountered an error that prevents recreating an index. Online log: Assertion Failure or Assertion Warning with problem details. Server state: Online. User action: Review the online.log file for the index information, and then drop and recreate the index manually.
Class ID: 3 1 Event ID: 1013	3	Class message: Table failure: 'dbname:"owner".tablename' Specific message: An internal error occurred while the database server was trying to initialize the type of set read operation.	The database server was unable to initialize internal data structures for a set read operation. Online log: Assertion Warning with database and table details. Server state: Online. User action: Review the online.log file for ISAM error codes, and table and database information. Try the operation again. If the operation fails again, note all circumstances and contact IBM Software Support.
Class ID: 3 1 Event ID: 1014	3	Class message: Table failure: 'dbname:"owner".tablename' Specific message: An internal error occurred while the database server was trying to read records from the tblspace's pages	The database server encountered an internal error when reading records from a table or index. Online log: Assertion Warning with database and table details. Server state: Online. User action: Review the online.log file for table and database information. Try the operation again. If the operation fails again, note all circumstances and contact IBM Software Support.

Table C-3. Event Alarms (continued)

ID	Severity	Messages	Explanation
Class ID: 1 Event ID: 1015	3	Class message: Table failure: 'dbname:"owner".tablename' Specific message: An internal error occurred while the database server was trying to read the current record.	The database server encountered an internal error when reading records from a table or index. Online log: Assertion Warning with database and table details. Server state: Online. User action: Review the online.log file for table and database information. Try the operation again. If the operation fails again, note all circumstances and contact IBM Software Support.
Class ID: 1 Event ID: 1016	3	Class message: Table failure: 'dbname:"owner".tablename' Specific message: An internal error occurred while the database server was trying to initialize the set read buffer.	An internal error was triggered when the database server attempted to initialize a set read buffer. Online log: Assertion Warning with database and table details. Server state: Online. User action: Review the online.log file for table and database information. Try the operation again. If the operation fails again, note all circumstances and contact IBM Software Support.
Class ID: 1 Event ID: 1017	3	Class message: Table failure: 'dbname:"owner".tablename' Specific message: An internal error occurred while the database server was trying to set the new mode on the bitmap page.	An internal error occurred during the conversion of a bitmap page from an earlier version of the database server. Online log: Assertion Warning with problem details. Server state: Online. User action: None.
Class ID: 1 Event ID: 1018	3	Class message: Table failure: 'dbname:"owner".tablename' Specific message: An internal error occurred while the database server was attempting to convert bitmap pages to the correct format.	The database server was unable to correct an error which occurred during a bitmap page conversion. Online log: Assertion Warning with problem details. Server state: Online. User action: Note all circumstances, review the online.log file for additional information, and contact IBM Software Support.

Table C-3. Event Alarms (continued)

ID	Severity	Messages	Explanation
Class ID: 1 Event ID: 1019	3	Class message: Table failure: 'dbname:"owner".tablename' Specific message: An internal error occurred while the database server was trying to modify the bitmap pages during light append operation.	The database server encountered an internal error during a light append operation and could not locate the required bitmap page. Online log: Assertion Warning with problem details. Server state: Online. User action: Try the operation again. If the operation fails again, note all circumstances and contact IBM Software Support.
Class ID: 1 Event ID: 1020	3	Class message: Table failure: 'dbname:"owner".tablename' Specific message: An internal error occurred while the database server was trying to perform light scan operation.	The database server encountered an internal error while performing a light scan operation. Online log: Assertion Warning with problem details. Server state: Online. User action: Try the operation again. If the operation fails again, note all circumstances and contact IBM Software Support.
Class ID: 1 Event ID: 1021	3	Class message: Table failure: 'dbname:"owner".tablename' Specific message: An internal error occurred while the database server was trying to perform light scan I/O operation.	The database server encountered an internal error while performing a light scan operation. Online log: Assertion Warning with problem details. Server state: Online. User action: Try the operation again. If the operation fails again, note all circumstances and contact IBM Software Support.
Class ID: 1 Event ID: 1022	3	Class message: Table failure: 'dbname:"owner".tablename' Specific message: An internal error was reported by the database server when it tried to validate light append buffer.	The database server encountered an internal error while performing a light scan operation. Online log: Assertion Warning with problem details. Server state: Online. User action: Try the operation again. If the operation fails again, note all circumstances and contact IBM Software Support.

Table C-3. Event Alarms (continued)

ID	Severity	Messages	Explanation
Class ID: 1 Event ID: 1023	3	Class message: Table failure: 'dbname:"owner".tablename' Specific message: An internal error was reported by the database server when it tried to write the next record to the page in the light append buffer.	The database server encountered an internal error while performing a light scan operation. Online log: Assertion Warning with problem details. Server state: Online. User action: Try the operation again. If the operation fails again, note all circumstances and contact IBM Software Support.
Class ID: 1 Event ID: 1024	4	Class message: Table failure: 'dbname:"owner".tablename' Specific message: An internal error was reported by the database server when it tried to open a light append for a tblspace.	The database server encountered an internal error during a light append operation on a tblspace. Online log: Assertion failure. Server state: Online. User action: Try the operation again. If the operation fails again, note all circumstances and contact IBM Software Support.
Class ID: 1 Event ID: 1025	4	Class message: Table failure: 'dbname:"owner".tablename' Specific message: An internal error was reported by the database server when it tried to load the first bitmap page for a light append operation.	The database server encountered an internal error during a light append operation. Online log: Assertion Failure : Light Append(Redo/Undo): Can't find bitmap page Server state: Online. User action: Try the operation again. If the operation fails again, note all circumstances and contact IBM Software Support.
Class ID: 1 Event ID: 1026	4	Class message: Table failure: 'dbname:"owner".tablename' Specific message: An internal error was reported by the database server when it tried to write the cached bitmap pages for a light append operation.	The database server encountered an internal error during a light append operation. Online log: Assertion failure. Server state: Online. User action: Try the operation again. If the operation fails again, note all circumstances and contact IBM Software Support.
Class ID: 1 Event ID: 1027	2	Class message: Table failure: 'dbname:"owner".tablename' Specific message: An internal deadlock database condition was caught by the Lock Manager in the database server.	The database server detected an internal deadlock database condition. Online log: Assertion warning identifying the databases and tables involved in the deadlock. Server state: Online. User action: None.

Table C-3. Event Alarms (continued)

ID	Severity	Messages	Explanation
Class ID: 1 Event ID: 1028	2	Class message: Table failure: 'dbname:"owner".tablename' Specific message: An internal deadlock database condition was caught by the Lock Manager in the database server.	The database server detected an internal deadlock database condition. Online log: Assertion warning identifying the databases and tables involved in the deadlock. Server state: Online. User action: None.
Class ID: 1 Event ID: 1029	4	Class message: Table failure: 'dbname:"owner".tablename' Specific message: An internal error was reported by the database server when it tried to map the logical page number in the tblspace to its physical location in the chunk.	The database server could not access a table because of an inconsistency between the physical page and its logical page number. Online log: Assertion failure with the page information. Server state: Online. User action: Run the oncheck -cDI command on the table mentioned in the class message or on the database, fix any issues reported, and then try the operation again. If the operation fails again, note all circumstances and contact IBM Software Support.
Class ID: 1 Event ID: 1030	3	Class message: Table failure: 'dbname:"owner".tablename' Specific message: An internal error was reported by the database server when it tried to allocate the alter information.	The database server encountered an internal error when attempting to read an internal disk structure. Online log: Assertion Warning with problem details and table and database information. Server state: Online. User action: Try the operation again. If the operation fails again, note all circumstances and contact IBM Software Support.
Class ID: 1 Event ID: 1031	3	Class message: Table failure: 'dbname:"owner".tablename' Specific message: An internal error was reported by the database server when it tried to prepare the list of operations to be performed on a compressed row.	The database server encountered an internal error when it tried to create an internal operations list to transform a compressed version of a row to an uncompressed version of the latest row. Online log: Assertion Warning with problem details and table and database information. Server state: Online. User action: Try the operation again. If the operation fails again, note all circumstances and contact IBM Software Support.

Table C-3. Event Alarms (continued)

ID	Severity	Messages	Explanation
Class ID: 1 Event ID: 1032	3	Class message: Table failure: 'dbname:"owner".tablename' Specific message: An internal error was reported by the database server when it tried to insert an operation in the list of operations based on the offset in the row where the new operation points to.	The database server encountered an internal error when it tried to create an internal operations list to transform a compressed version of a row to an uncompressed version of the latest row. Online log: Assertion Warning with problem details and table and database information. Server state: Online. User action: Try the operation again. If the operation fails again, note all circumstances and contact IBM Software Support.
Class ID: 1 Event ID: 1033	3	Class message: Table failure: 'dbname:"owner".tablename' Specific message: An internal error was reported by the database server when it detected an inconsistency with the operation list.	The database server encountered an internal error when it tried to create an internal operations list to transform a compressed version of a row to an uncompressed version of the latest row. Online log: Assertion Warning with problem details and table and database information. Server state: Online. User action: Try the operation again. If the operation fails again, note all circumstances and contact IBM Software Support.
Class ID: 1 Event ID: 1034	3	Class message: Table failure: 'dbname:"owner".tablename' Specific message: An internal error was reported by the database server when it tried to free the partition header page.	The database server encountered an internal error when attempting to free the header page for a partition. The database server did not free the header page. Online log: Assertion Warning with problem details, table and database information, and a specific oncheck command to run. Server state: Online. User action: Review the online.log file for information and run the specified oncheck command.
Class ID: 1 Event ID: 1035	3 or 4	Class message: Table failure: 'dbname:"owner".tablename' Specific message: An internal error was reported by the database server when it tried to validate the partition header page.	The database server cannot access a table because of a validation error for the tblspace page. Online log: Assertion with details about the table. Server state: Online. User action: Examine the online log for information about the specified table. Run the oncheck -pt command on the table or on the database and correct any errors found. Retry the original operation. If the operation fails again, note all circumstances and contact IBM Software Support.

Table C-3. Event Alarms (continued)

ID	Severity	Messages	Explanation
Class ID: 1 Event ID: 1036	3	Class message: Table failure: 'dbname:"owner".tablename' Specific message: An internal error was reported by the database server when it tried to update the special columns list during an alter table command processing.	The database server encountered an internal error when processing the special columns list associated with a table while the table was being altered. Online log: Assertion Warning with problem details, table and database information, and a specific oncheck command to run. Server state: Online. User action: Review the online.log file for information and run the specified oncheck command.
Class ID: 1 Event ID: 1037	3	Class message: Table failure: 'dbname:"owner".tablename' Specific message: An internal error was reported by the database server when it tried to log the completion of the alter and remove the associated version information from the tblspace's header page.	The database server encountered an internal error when attempting to alter a table. Online log: Assertion Warning with problem details, table and database information, and a specific oncheck command to run. Server state: Online. User action: Review the online.log file for information and run the specified oncheck command.
Class ID: 1 Event ID: 1038	3	Class message: Table failure: 'dbname:"owner".tablename' Specific message: An internal error was reported by the database server when it detected a buffer inconsistency.	The database server encountered an internal error during a consistency check of the internal buffers it was manipulating. Online log: Assertion Warning with problem details, table and database information, and a specific oncheck command to run. Server state: Online. Retry the original operation. If the operation fails again, note all circumstances and contact IBM Software Support.
Class ID: 1 Event ID: 1039	3	Class message: Table failure: 'dbname:"owner".tablename' Specific message: An internal error was reported by the database server when it tried to construct a forwarded row into a single tuple.	The database server encountered an internal error when processing rows. Online log: Assertion Warning with problem details, and table and database information. Server state: Online. User action: Review the online.log file for more information. Retry the original operation. If the operation fails again, note all circumstances and contact IBM Software Support.

Table C-3. Event Alarms (continued)

ID	Severity	Messages	Explanation
Class ID: 1 Event ID: 1040	3	<p>Class message:</p> <p>Table failure: 'dbname:"owner".tablename'</p> <p>Specific message:</p> <p>An internal error was reported by the database server when it tried to read the data from a partition into the set read buffer.</p>	
Class ID: 1 Event ID: 1041	3	<p>Class message:</p> <p>Table failure: 'dbname:"owner".tablename'</p> <p>Specific message:</p> <p>An internal error was reported by the database server when it tried to read the data row for a given rowid.</p>	
Class ID: 1 Event ID: 1042	3	<p>Class message:</p> <p>Table failure: 'dbname:"owner".tablename'</p> <p>Specific message:</p> <p>An internal error was reported by the database server when it tried to alter the row in memory to the latest schema.</p>	
Class ID: 1 Event ID: 1043	3	<p>Class message:</p> <p>Table failure: 'dbname:"owner".tablename'</p> <p>Specific message:</p> <p>An internal error was reported by the database server when it tried to undo the alter of a bitmap page.</p>	
Class ID: 1 Event ID: 1044	3	<p>Class message:</p> <p>Table failure: 'dbname:"owner".tablename'</p> <p>Specific message:</p> <p>An internal error was reported by the database server when it tried to undo the addition of special column descriptors from the tblspace's header page.</p>	
Class ID: 1 Event ID: 1045	3	<p>Class message:</p> <p>Table failure: 'dbname:"owner".tablename'</p> <p>Specific message:</p> <p>An internal error was reported by the database server when it tried to undo the addition of the new version to a partition.</p>	

Table C-3. Event Alarms (continued)

ID	Severity	Messages	Explanation
Class ID: 1 Event ID: 1046	3	Class message: Table failure: 'dbname:"owner".tablename' Specific message: An internal error was reported by the database server when it tried to allocate the file descriptor for a partnum.	
Class ID: 1 Event ID: 1047	3	Class message: Table failure: 'dbname:"owner".tablename' Specific message: An internal error was reported by the database server when it tried to free the file descriptor for a partnum.	
Class ID: 1 Event ID: 1048	3	Class message: Table failure: 'dbname:"owner".tablename' Specific message: Error updating table record.	
Class ID: 2 Event ID: 2001	3 or 4	Class message: Index failure: 'dbname:"owner".tablename:idxname' Specific message: Frigid <i>fragment_id</i> , Rowid <i>rowid</i> not found for delete in partnum <i>partition_number</i>	The database server did not delete a record because it could not find it in the index. Online log: Assertion indicating that a DELETE operation failed and details of the table and index where the problem occurred. Server state: Online. User action: Run the oncheck -cI command on the specified table and index, or on the database, and correct any errors found. Retry the original operation. If the operation fails again, note all circumstances and contact IBM Software Support.
Class ID: 2 Event ID: 2002	3	Class message: Index failure: 'dbname:"owner".tablename:idxname' Specific message: An internal error was raised due to an inconsistency in the index which is preventing the database server to position on the first record in that index.	

Table C-3. Event Alarms (continued)

ID	Severity	Messages	Explanation
Class ID: 2 Event ID: 2003	3	Class message: Index failure: <i>'dbname:"owner".tablename:idxname'</i> Specific message: An internal error was raised due to an inconsistency in the index which is preventing the database server to read ahead pages in that index.	
Class ID: 2 Event ID: 2004	4	Class message: Index failure: <i>'dbname:"owner".tablename-idxname'</i> Specific message: Page Check Error in <i>object</i>	The database server detected inconsistencies with an index. Online log: Various messages depending on where the issue was detected. For example: Possible inconsistencies in a DBSpace TBLSpace Run 'oncheck -cD' on all DBSpace TBLSpaces Server state: Online. User action: Examine the online log file and run the recommended oncheck -cD command on the database.
Class ID: 2 Event ID: 2005	3	Class message: Index failure: <i>'dbname:"owner".tablename:idxname'</i> Specific message: An internal error occurred during batched index read because the database server had an invalid index key item.	
Class ID: 2 Event ID: 2006	3	Class message: Index failure: <i>'dbname:"owner".tablename:idxname'</i> Specific message: <i>index_page</i> log record too large to fit into the logical log buffer. Recommended minimum value for LOGBUFF is <i>number</i> .	
Class ID: 2 Event ID: 2007	3	Class message: Index failure: <i>'dbname:"owner".tablename:idxname'</i> Specific message: Comparison based on locale ' <i>locale_name</i> ' failed	

Table C-3. Event Alarms (continued)

ID	Severity	Messages	Explanation
Class ID: 2 Event ID: 2008	3	Class message: Index failure: <i>'dbname:"owner".tablename:idxname'</i> Specific message: Comparison failed	
Class ID: 2 Event ID: 2009	4	Class message: Index failure: <i>'dbname:"owner".tablename:idxname'</i> Specific message: An internal error occurred while the database server was trying to add a new item to the index.	The database server could not insert a record into an index. Online log: Assertion specifying the index and the recommended oncheck command to run. Server state: Online. User action: Examine the online log file and run the recommended oncheck command.
Class ID: 2 Event ID: 2010	4	Class message: Index failure: <i>'dbname:"owner".tablename:idxname'</i> Specific message: An internal error was raised due to an inconsistency in the index which is preventing the database server to position at the correct item in the index.	The database server could not retrieve the correct item in the index because of an inconsistency in the index. Online log: Assertion specifying the index and the recommended oncheck command to run. Server state: Online. User action: Examine the online log file and run the recommended oncheck command.
Class ID: 2 Event ID: 2011	3	Class message: Index failure: <i>'dbname:"owner".tablename:idxname'</i> Specific message: Cannot drop index <i>index_name</i> for partnum <i>partition_number</i> , iserrno = <i>error_number</i>	
Class ID: 2 Event ID: 2012	3	Class message: Index failure: <i>'dbname:"owner".tablename:idxname'</i> Specific message: An internal error occurred while the database server was trying to mark an index key descriptor as bad.	

Table C-3. Event Alarms (continued)

ID	Severity	Messages	Explanation
Class ID: 2 Event ID: 2013	4	Class message: Index failure: <i>'dbname:"owner".tablename:idxname'</i> Specific message: An internal error occurred while the database server was trying to delete an item from the index.	The database server could not delete a record from an index. Online log: Assertion specifying the index and the recommended oncheck command to run. Server state: Online. User action: Examine the online log file and run the recommended oncheck command.
Class ID: 3 Event ID: 3001	3	Class message: Blob failure: <i>'dbname:"owner".tablename'</i> Specific message: tb_sockid in blob descriptor is corrupted. Current table is <i>'dbname:"owner".tablename'</i>	
Class ID: 3 Event ID: 3002	3	Class message: Blob failure: <i>'dbname:"owner".tablename'</i> Specific message: Incorrect BLOB stamps.	
Class ID: 3 Event ID: 3003	4	Class message: Blob failure: <i>'dbname:"owner".tablename'</i> Specific message: BLOB Page Check error at <i>dbspace_name</i>	The database server performed a check on pages that are moving between disk and memory and the check failed. Online log: Assertion describing the error. Server state: Online. User action: Try the operation again. If the operation fails again, note all circumstances and contact IBM Software Support.
Class ID: 3 Event ID: 3004	3	Class message: Blob failure: <i>'dbname:"owner".tablename'</i> Specific message: An internal error occurred while trying to read a blob from a table.	
Class ID: 3 Event ID: 3005	3	Class message: Blob failure: <i>'dbname:"owner".tablename'</i> Specific message: An internal error occurred while trying to copy a blob from a table.	

Table C-3. Event Alarms (continued)

ID	Severity	Messages	Explanation
Class ID: 4 4 Event ID: 4001	4	Class message: Chunk is offline, mirror is active: <i>chunk_number</i> Specific message: I/O error, <i>error_number</i> Chunk ' <i>chunk_number</i> ' -- Offline	An error has occurred reading from or writing to a chunk. The database server has taken the chunk offline and switched to performing all I/O operations on the active mirrored chunk. Online log: Assertion describing the error that occurred. Server state: Online. User action: Examine the online log for information and fix the error. Run the onspaces -s command to recover the offline chunk. Retry the original operation. If the operation fails again, note all circumstances and contact IBM Software Support.
Class ID: 4 4 Event ID: 4002	3 or 4	Class message: Chunk is offline, mirror is active: <i>chunk_number</i> Specific message: An internal error occurred during physical I/O because the chunk was not opened.	The database server cannot access a chunk and switched to performing all I/O operations on the active mirrored chunk. Online log: Assertion describing the error and information about the chunk where the problem occurred. Server state: Online. User action: Examine the online log, fix any errors, and recover the mirror by using the onspaces utility. If the operation fails again, note all circumstances and contact IBM Software Support.
Class ID: 4 4 Event ID: 4003	3	Class message: Chunk is offline, mirror is active: <i>chunk_number</i> Specific message: I/O error, <i>error_number</i> Chunk ' <i>chunk_number</i> ' -- Offline (sanity)	
Class ID: 4 4 Event ID: 4004	3	Class message: Chunk is offline, mirror is active: <i>chunk_number</i> Specific message: Chunk failed sanity check	
Class ID: 4 4 Event ID: 4005	3	Class message: Chunk is offline, mirror is active: <i>chunk_number</i> Specific message: Mirror Chunk <i>chunk_number</i> added to space ' <i>space_number</i> '. Perform manual recovery.	

Table C-3. Event Alarms (continued)

ID	Severity	Messages	Explanation
<p>Class ID: 4</p> <p>5</p> <p>Event ID: 5001</p>	4	<p>Class message:</p> <p>Dbospace is offline: '<i>dbospace_name</i>'</p> <p>Specific message:</p> <p>Chunk <i>chunk_number</i> is being taken OFFLINE.</p>	<p>The database server took a dbospace offline because of an error in accessing a chunk.</p> <p>Online log: Assertion failure if the dbospace was a critical dbospace, such as the rootdbs. Assertion warning if the dbospace is not critical. Both provide information about the chunk and dbospace being taken offline.</p> <p>Server state: Online if a non-critical media failure. Offline if a critical media failure.</p> <p>User action: Examine the online log file and fix the underlying problem that caused the dbospace to be taken offline. You might need to restore the dbospace.</p>
<p>Class ID: 4</p> <p>5</p> <p>Event ID: 5002</p>	4	<p>Class message:</p> <p>Dbospace is offline: '<i>dbospace_name</i>'</p> <p>Specific message:</p> <p>WARNING! Chunk <i>chunk_number</i> is being taken OFFLINE for testing.</p>	<p>The database server has taken a dbospace offline as a result of an onmode command.</p> <p>Online log: Assertion warning indicating that the dbospace has been taken offline.</p> <p>Server state: Online.</p> <p>User action: None.</p>
<p>Class ID: 6</p> <p>6016</p> <p>Event ID: 6016</p>	3	<p>Class message:</p> <p>Internal subsystem failure: '<i>message</i>'</p> <p>Specific message:</p> <p>Pool not freed. pool name:<i>pool_name</i>, address:<i>address</i></p>	
<p>Class ID: 6</p> <p>6017</p> <p>Event ID: 6017</p>	4	<p>Class message:</p> <p>Internal subsystem failure: '<i>message</i>'</p> <p>Specific message:</p> <p>CDR Grouper FanOut thread is aborting</p>	<p>A problem occurred with Enterprise Replication.</p> <p>Online log: Assertion describing the problem.</p> <p>Server state: Online.</p> <p>User action: Follow the instructions in the online log.</p>
<p>Class ID: 6</p> <p>6018</p> <p>Event ID: 6018</p>	4	<p>Class message:</p> <p>Internal subsystem failure: '<i>message</i>'</p> <p>Specific message:</p> <p>CDR Pager: Paging File full: Waiting for additional space in CDR_QDATA_SBSPACE</p>	<p>The storage space of an Enterprise Replication queue is full.</p> <p>Online log: Assertion describing the problem.</p> <p>Server state: Online.</p> <p>User action: Add a chunk to one or more of the sbspaces specified by the CDR_QDATA_SBSPACE configuration parameter.</p>

Table C-3. Event Alarms (continued)

ID	Severity	Messages	Explanation
Class ID: 3 6 Event ID: 6021	3	Class message: Internal subsystem failure: 'message' Specific message: An internal error was reported by the database server during conversion when it found some indices in the old format.	
Class ID: 3 6 Event ID: 6022	3	Class message: Internal subsystem failure: 'message' Specific message: An internal error was reported by the database server when it checks for any new in-place alter pending in the current server during reversion.	
Class ID: 3 6 Event ID: 6023	3	Class message: Internal subsystem failure: 'message' Specific message: Cannot open index 'dbname:index_name', iserrno = error_number	
Class ID: 3 6 Event ID: 6024	3	Class message: Internal subsystem failure: 'message' Specific message: Cannot drop index 'dbname:index_name', iserrno = error_number	
Class ID: 3 6 Event ID: 6025	3	Class message: Internal subsystem failure: 'message' Specific message: Cannot open table 'dbname:table_name', iserrno = error_number	
Class ID: 3 6 Event ID: 6026	3	Class message: Internal subsystem failure: 'message' Specific message: Cannot drop table 'dbname:table_name', iserrno = error_number	

Table C-3. Event Alarms (continued)

ID	Severity	Messages	Explanation
Class ID: 3 6 Event ID: 6027		Class message: Internal subsystem failure: 'message' Specific message: An error was reported by the database server when it tried to drop the sysmaster database during reversion	
Class ID: 3 6 Event ID: 6028		Class message: Internal subsystem failure: 'message' Specific message: Optical Subsystem STARTUP Error	
Class ID: 2 6 Event ID: 6029		Class message: Internal subsystem failure: 'message' Specific message: Unable to initiate communications with the Optical Subsystem	The database server could not communicate with the Optical Subsystem during the initialization of the server. Online log: Message indicating that the database server is unable to communicate with the Optical Subsystem. Server state: Offline. User action: Check the installation of the optical driver and the cabling between the computer and the drive.
Class ID: 3 6 Event ID: 6030		Class message: Internal subsystem failure: 'message' Specific message: Invalid or missing name for Subsystem Staging BLOBspace	
Class ID: 2 6 Event ID: 6031		Class message: Internal subsystem failure: 'message' Specific message: Optical Subsystem is running	The database server initialized the Optical Subsystem. Online log: Message stating that the Optical Subsystem is running. Server state: Online. User action: None.
Class ID: 2 6 Event ID: 6032		Class message: Internal subsystem failure: 'message' Specific message: Optical Subsystem is not running	The Optical Subsystem is no longer running. Online log: Message stating that the Optical Subsystem is not running. Server state: Online. User action: Review the messages in the log of the optical driver to identify the reason that the Optical Subsystem stopped running.

Table C-3. Event Alarms (continued)

ID	Severity	Messages	Explanation
Class ID: 5 6 Event ID: 6033	5	Class message: Internal subsystem failure: 'message' Specific message: Cache read error	The database server shut down after encountering an error while reading an internal cache. Online log: Assertion Failure. Server State: Offline. User action: Start the database server and try the operation again. If the operation fails again, note all circumstances and contact IBM Software Support.
Class ID: 3 6 Event ID: 6034	3	Class message: Internal subsystem failure: 'message' Specific message: Could not start remote server	
Class ID: 3 6 Event ID: 6035	3	Class message: Internal subsystem failure: 'message' Specific message: An error was reported by the database server during the handling of audit trail files.	
Class ID: 3 6 Event ID: 6036	3	Class message: Internal subsystem failure: 'message' Specific message: Archive on <i>dbspaces_list</i> ABORTED	
Class ID: 3 6 Event ID: 6037	3	Class message: Internal subsystem failure: 'message' Specific message: Waiting on BLOBSpace to appear for Logical Recovery	
Class ID: 3 6 Event ID: 6038	3	Class message: Internal subsystem failure: 'message' Specific message: An internal error reported by the database server. Users may need to look at the specific message which accompanies with this id.	

Table C-3. Event Alarms (continued)

ID	Severity	Messages	Explanation
Class ID: 3 6 Event ID: 6039	3	Class message: Internal subsystem failure: 'message' Specific message: Wrong page for cleaning deleted items	
Class ID: 3 6 Event ID: 6040	3	Class message: Internal subsystem failure: 'message' Specific message: Buffer in wrong state for cleaning deleted items	
Class ID: 5 or 3 6 Event ID: 6041	5 or 3	Class message: Internal subsystem failure: 'message' Specific message: An internal error was detected by the Buffer Manager in the database server.	For severity 5, the database server buffer manager encountered an internal error and either shut down or corrected the problem. Online log: Assertion warning or an assertion failure with a description of the operation being performed at the time of the error. Typically, an assertion warning shows that the error was internally corrected. Server State: Offline if the error was unrecoverable. Online if the error was corrected. User action: If the error was unrecoverable, start the database server and try the operation again. If the operation fails again, note all circumstances and contact IBM Software Support. No action is required if the error was internally corrected by the database server.
Class ID: 5 or 2 6 Event ID: 6042	5 or 2	Class message: Internal subsystem failure: 'message' Specific message: An internal error was reported by the database server when it detected an inconsistency with the internal buffer queues.	For severity 5, the database server detected an inconsistency during the processing of internal buffer queues and either shut down or corrected the problem. Online log: Assertion warning or an assertion failure with a description of the operation being performed at the time of the error. Typically, an assertion warning shows that the error was internally corrected. Server State: Offline if the error was unrecoverable. Online if the error was corrected. User action: If the error was unrecoverable, start the database server and try the operation again. If the operation fails again, note all circumstances and contact IBM Software Support. No action is required if the error was internally corrected by the database server.

Table C-3. Event Alarms (continued)

ID	Severity	Messages	Explanation
Class ID: 3 6 Event ID: 6043	3	Class message: Internal subsystem failure: 'message' Specific message: Internal file error	
Class ID: 3 6 Event ID: 6044	3	Class message: Internal subsystem failure: 'message' Specific message: An internal error was corrected automatically by the database server when it tried to save the log buffer into a system log buffer.	
Class ID: 5 6 Event ID: 6045	5	Class message: Internal subsystem failure: 'message' Specific message: Logical logging error for 'object' in 'space'	The database server shut down because of an error while processing logical logs. Online log: Assertion failure with a description of the operation and logical log information. Server State: Offline. User action: Start the database server. If the operation fails again, note all circumstances and contact IBM Software Support.
Class ID: 4 6 Event ID: 6046	4	Class message: Internal subsystem failure: 'message' Specific message: Page Check Error in <i>object</i>	The database server detected inconsistencies in the data. Online log: Various outputs depending upon where the issue was detected. For example: Possible inconsistencies in a DBSpace TBLSpace Run 'oncheck -cD' on all DBSpace TBLSpaces Server state: Online. User action: Examine the online log file and run the recommended oncheck -cD command on the database.
Class ID: 3 6 Event ID: 6047	3	Class message: Internal subsystem failure: 'message' Specific message: Errors occurred while recreating indexes	

Table C-3. Event Alarms (continued)

ID	Severity	Messages	Explanation
Class ID: 6 Event ID: 6049	5	Class message: Internal subsystem failure: 'message' Specific message: Lock types <i>lock_type</i> and <i>lock_type</i> should never be merged	The database server shut down after attempting to merge incompatible locks. Online log: Assertion failure with the lock types that the database server was attempting to merge. Server State: Offline. User action: Start the database server. If the operation fails again, note all circumstances and contact IBM Software Support.
Class ID: 6 Event ID: 6050	5	Class message: Internal subsystem failure: 'message' Specific message: An internal error was reported by the database server when it detected some corruption in the lock free list chain.	The database server shut down after detecting corruption of an internal structure that manages an internal list of free locks. Online log: Assertion failure. Server State: Offline. User action: Start the database server. If the operation fails again, note all circumstances and contact IBM Software Support.
Class ID: 6 Event ID: 6051	3	Class message: Internal subsystem failure: 'message' Specific message: ERROR - NO 'waitfor' locks in Critical Section!!!	
Class ID: 6 Event ID: 6052	3	Class message: Internal subsystem failure: 'message' Specific message: Internal Tblspace error	
Class ID: 6 Event ID: 6053	3	Class message: Internal subsystem failure: 'message' Specific message: Session does not have exclusive access to partition <i>partition_name</i> . Request to drop the partition ignored.	
Class ID: 6 Event ID: 6054	3	Class message: Internal subsystem failure: 'message' Specific message: Error building 'sysmaster' database.	

Table C-3. Event Alarms (continued)

ID	Severity	Messages	Explanation
Class ID: 6 Event ID: 6055	3	Class message: Internal subsystem failure: 'message' Specific message: Setread error on SMI Table, partnum <i>partition_number</i>	
Class ID: 6 Event ID: 6056	3	Class message: Internal subsystem failure: 'message' Specific message: Comparison based on locale ' <i>locale_name</i> ' failed	
Class ID: 6 Event ID: 6057	2	Class message: Internal subsystem failure: 'message' Specific message: DBSPACETEMP internal list not initialized, using default	The database server did not create the necessary structures for holding the DBSPACETEMP information. Online log: Message stating that the internal DBSPACETEMP list was not initialized. Server state: Online. User action: None.
Class ID: 6 Event ID: 6058	3	Class message: Internal subsystem failure: 'message' Specific message: A data source accessed using a gateway (<i>gateway_name</i>) might be in an inconsistent state	
Class ID: 6 Event ID: 6059	3	Class message: Internal subsystem failure: 'message' Specific message: Prepared participant site <i>site_name</i> not responding	
Class ID: 6 Event ID: 6060	5	Class message: Internal subsystem failure: 'message' Specific message: Thread exited with <i>number</i> buffers held	The database server shut down after detecting that a thread is holding one or more buffers. Online log: Assertion failure with the number of buffers being held by the thread. Server State: Offline. User action: Bring the database server online. If the operation fails again, note all circumstances and contact IBM Software Support.

Table C-3. Event Alarms (continued)

ID	Severity	Messages	Explanation
Class ID: 6 Event ID: 6061	3	<p>Class message:</p> <p>Internal subsystem failure: 'message'</p> <p>Specific message:</p> <p>An internal error was automatically corrected by the database server when it detected that the undo log for the transaction was not applicable.</p>	
Class ID: 6 Event ID: 6062	3	<p>Class message:</p> <p>Internal subsystem failure: 'message'</p> <p>Specific message:</p> <p>Internal Error - Freeing transaction entry that still holds locks!</p>	<p>While freeing resources associated with a transaction, the database server detected that the transaction is holding locks. In most circumstances the database server can release these locks.</p> <p>Online log: Assertion warning with the transaction and a statement that the database server internally corrected the problem.</p> <p>Server State: Online.</p> <p>User action: If the database server shut down, start the database server.</p>
Class ID: 6 Event ID: 6063	3	<p>Class message:</p> <p>Internal subsystem failure: 'message'</p> <p>Specific message:</p> <p>User thread not on TX wait list</p>	
Class ID: 6 Event ID: 6064	3	<p>Class message:</p> <p>Internal subsystem failure: 'message'</p> <p>Specific message:</p> <p>Due to a heuristic decision, the work done on behalf of the specified transaction branch might have been heuristically completed or committed or rolled back or partially committed and partially rolled back.</p>	
Class ID: 6 Event ID: 6065	3	<p>Class message:</p> <p>Internal subsystem failure: 'message'</p> <p>Specific message:</p> <p>Errors occurred while recreating indexes</p>	
Class ID: 6 Event ID: 6066	3	<p>Class message:</p> <p>Internal subsystem failure: 'message'</p> <p>Specific message:</p> <p>An internal error is reported by the database server when it has checked all sites to see if a heuristic rollback was the reason for the failure.</p>	

Table C-3. Event Alarms (continued)

ID	Severity	Messages	Explanation
Class ID: 5 6 Event ID: 6067	5	Class message: Internal subsystem failure: 'message' Specific message: A fatal internal error (Recursive exception) has caused the database server processes to terminate unexpectedly.	The database server detected recursive calls to exception handling and immediately shut down to avoid an infinite loop. Online log: Assertion failure. Server State: Offline. User action: Start the database server. If the operation fails again, note all circumstances and contact IBM Software Support.
Class ID: 5 6 Event ID: 6068	5	Class message: Internal subsystem failure: 'message' Specific message: A fatal internal error (Internal exception) has caused the database server processes to terminate unexpectedly.	The database server shut down due to an unrecoverable internal error. Online log: Assertion failure with information about the exception that caused the problem. Server State: Offline. User action: Start the database server. Look at the exception information in the assertion failure file. If the exception relates to a user-defined routine, investigate and correct the user-defined routine. If the operation fails again, note all circumstances and contact IBM Software Support.
Class ID: 5 6 Event ID: 6069	5	Class message: Internal subsystem failure: 'message' Specific message: A fatal internal error (Master daemon died) has caused the database server processes to terminate unexpectedly.	The master daemon oninit process stopped and the database server shut down. This error can be caused by the termination of operating system processes. Online log: Assertion failure. Server State: Offline. User action: Start the database server. Be careful when terminating operating system processes.
Class ID: 5 6 Event ID: 6070	5	Class message: Internal subsystem failure: 'message' Specific message: A fatal internal error (VP died) has caused the database server processes to terminate unexpectedly.	An oninit process stopped and the database server shut down. This error can be caused by the termination of operating system processes. Online log: Assertion failure. Server State: Offline. User action: Start the database server. Be careful when terminating operating system processes.

Table C-3. Event Alarms (continued)

ID	Severity	Messages	Explanation
Class ID: 6 Event ID: 6071	5	Class message: Internal subsystem failure: 'message' Specific message: ERROR: can not fork secondary Server thread (MACH11 Shutdown)	The secondary server shut down but was unable to create a thread to shut down normally. Online log: DR: Shutting down the server. ERROR: can not fork secondary Server thread (MACH11 Shutdown) Can not run onmode -ky PANIC: Attempting to bring system down. Server State: Offline. User action: None.
Class ID: 6 Event ID: 6072	3	Class message: Internal subsystem failure: 'message' Specific message: Generic unique event id when the server failed to fork a new thread.	
Class ID: 6 Event ID: 6073	3	Class message: Internal subsystem failure: 'message' Specific message: An error was reported by the database server when it could not initialize GLS for starting a session.	
Class ID: 6 Event ID: 6074	3	Class message: Internal subsystem failure: 'message' Specific message: WARNING: mt_aio_wait: errno == EINVAL	
Class ID: 6 Event ID: 6075	5	Class message: Internal subsystem failure: 'message' Specific message: A fatal internal error (KAIO) has caused the database server processes to terminate unexpectedly.	The database server shut down because of an error in the KAIO subsystem. Online log: Assertion failure with the specific operation that failed. Server State: Offline. User action: Start the database server. If the operation fails again, note all circumstances and contact IBM Software Support.
Class ID: 6 Event ID: 6100		Generic event for when the database server implicitly raises an assert warning.	

Table C-3. Event Alarms (continued)

ID	Severity	Messages	Explanation
Class ID: 6 Event ID: 6300		Generic event for when the database server implicitly raises an assert failure.	
Class ID: 6 Event ID: 6500		Generic event for when the database server terminates unexpectedly due to an internal error condition.	<p>An internal error occurred and the database server shut down.</p> <p>Online log: Assertion failure.</p> <p>Server State: Offline.</p> <p>User action: Start the database server. Examine the assertion failure file for more information about what happened. If possible, fix any problems identified and try the operation again. If the operation fails again, note all circumstances and contact IBM Software Support.</p>
Class ID: 7 Event ID: 7001	3	<p>Class message:</p> <p>Database server initialization failure</p> <p>Specific message:</p> <p>TABLOCKS log record too large to fit into the logical log buffer. Recommended minimum value for LOGBUFF is <i>size</i>.</p> <p>I-STAR(C) begins prepare log record too large to fit into the logical log buffer. Recommended minimum value for LOGBUFF is <i>size</i>.</p> <p>Partition blob log record too large to fit into the logical log buffer. Recommended minimum value for LOGBUFF is <i>size</i>.</p> <p>Alter table special column desc log record too large to fit into the logical log buffer. Recommended minimum value for LOGBUFF is <i>size</i>.</p>	
Class ID: 7 Event ID: 7002	4	<p>Class message:</p> <p>Database server initialization failure</p> <p>Specific message:</p> <p>Unable to extend <i>number</i> reserved pages for checkpoint in ROOT chunk.</p> <p>Unable to extend <i>number</i> reserved pages for log in ROOT chunk.</p>	<p>The database server could not start because it could not allocate more space for internal structures in the initial root chunk.</p> <p>Online log: Assertion.</p> <p>Server state: Offline.</p> <p>User action: Try the operation again. If the operation fails again, note all circumstances and contact IBM Software Support.</p>

Table C-3. Event Alarms (continued)

ID	Severity	Messages	Explanation
Class ID: 7 Event ID: 7003	4	Class message: Database server initialization failure Specific message: An internal error occurred during conversion. Users may need to take a look at the specific messages for further action.	The database server could not start during an upgrade because an internal error occurred during the conversion process. Online log: Assertion describing the error. Server state: Offline. User action: Look at the online log and the specific message and take the necessary corrective action. Try the operation again. If the operation fails again, note all circumstances and contact IBM Software Support.
Class ID: 7 Event ID: 7004	4	Class message: Database server initialization failure Specific message: An internal error occurred while trying to convert the database tblspace.	The database server cannot start because of an internal error when trying to convert the database tblspace, which holds information about the databases in the instance. Online log: Assertion describing the error. Server state: Offline. User action: Contact IBM Software Support.
Class ID: 7 Event ID: 7005	4	Class message: Database server initialization failure Specific message: An internal error occurred while trying to convert blob free map pages.	The database server cannot start because of an internal error when trying to convert blob space free-map pages. Online log: Assertion describing the error. Server state: Offline. User action: Contact IBM Software Support.
Class ID: 7 Event ID: 7006	4	Class message: Database server initialization failure Specific message: Cannot Open Logical Log.	The database server cannot start because it is still restoring physical or logical logs. This situation can occur if the onmode -m or onmode -s command is run before the restore is complete. Online log: Assertion describing the error. Server state: Recovering and starting. User action: Run the onmode -m or onmode -s command after the restore is complete.
Class ID: 7 Event ID: 7007	4	Class message: Database server initialization failure Specific message: Logical Log File not found.	The database server cannot start because a logical log file is missing. Online log: Assertion describing the error. Server state: Offline. User action: Restore the database server from a backup.

Table C-3. Event Alarms (continued)

ID	Severity	Messages	Explanation
Class ID: 3 7 Event ID: 7008	3	Class message: Database server initialization failure Specific message: WARNING! LTXHWM is set to 100%. This long transaction high water mark will never be reached. Transactions will not be aborted automatically by the server, regardless of their length.	
Class ID: 4 7 Event ID: 7009	4	Class message: Database server initialization failure Specific message: A Physical or Logical Restore is active.	The database server cannot start because it is still restoring physical or logical logs. This situation can occur if the onmode -m or onmode -s command is run before the restore is complete. Online log: Assertion describing the error. Server state: Recovering and starting. User action: Run the onmode -m or onmode -s command after the restore is complete.
Class ID: 4 7 Event ID: 7010	4	Class message: Database server initialization failure Specific message: <i>root_dbSPACE</i> has not been physically recovered.	The database server cannot start because the restore was interrupted before the rootdbs was physically restored. Online log: Assertion describing the error. Server state: Offline. User action: Restore the rootdbs.
Class ID: 4 7 Event ID: 7011	4	Class message: Database server initialization failure Specific message: <i>dbSPACE</i> has not been physically recovered.	The database cannot start because a dbSPACE is not physically restored. This situation can occur if the database server is attempted to be started before a restore is complete. Online log: Assertion describing the error. Server state: Offline. User action: Wait until the restore is complete before starting the database server.
Class ID: 4 7 Event ID: 7012	4	Class message: Database server initialization failure Specific message: <i>dbSPACE</i> not recovered from same archive backup as <i>dbSPACE</i> .	The database server cannot start because a dbSPACE was not restored successfully. Online log: Assertion describing the error. Server state: Offline. User action: Recover the dbSPACE from a backup and roll forward the necessary logs to bring the dbSPACE to the correct point in time.

Table C-3. Event Alarms (continued)

ID	Severity	Messages	Explanation
Class ID: 7 Event ID: 7013	4	<p>Class message:</p> <p>Database server initialization failure</p> <p>Specific message:</p> <p>Log <i>log_number</i> not found.</p>	<p>The database server cannot start because a restore is not complete.</p> <p>Online log: Assertion describing the error.</p> <p>Server state: Offline.</p> <p>User action: Wait until the restore is complete before starting the database server.</p>
Class ID: 7 Event ID: 7014	4	<p>Class message:</p> <p>Database server initialization failure</p> <p>Specific message:</p> <p>Logical restore cannot be skipped. Perform a logical restore.</p>	<p>The database server cannot start because a logical restore is not complete.</p> <p>Online log: Assertion describing the error.</p> <p>Server state: Offline.</p> <p>User action: Perform a logical restore (for example, by using the onbar -r -l command) and start the database server in quiescent or online mode.</p>
Class ID: 7 Event ID: 7015	4	<p>Class message:</p> <p>Database server initialization failure</p> <p>Specific message:</p> <p>Cannot change to On-Line or Quiescent mode.</p>	<p>The database server cannot start because of an error during fast or full recovery.</p> <p>Online log: Assertion describing the error.</p> <p>Server state: Offline.</p> <p>User action: Examine the online log for more information. Try the operation again. If the operation fails again, note all circumstances and contact IBM Software Support.</p>
Class ID: 7 Event ID: 7016	4	<p>Class message:</p> <p>Database server initialization failure</p> <p>Specific message:</p> <p>Cannot Open Primary Chunk '<i>chunk_number</i>'.</p>	<p>The database server cannot start because it could not access a primary chunk.</p> <p>Online log: Assertion describing the error.</p> <p>Server state: Offline.</p> <p>User action: Examine the online log for more information. Try the operation again. If the operation fails again, note all circumstances and contact IBM Software Support.</p>
Class ID: 7 Event ID: 7017	4	<p>Class message:</p> <p>Database server initialization failure</p> <p>Specific message:</p> <p>The chunk '<i>chunk_number</i>' must have owner-ID "<i>owner_id</i>" and group-ID "<i>group_id</i>".</p>	<p>The database server cannot start because the owner and group of a chunk path are not correct.</p> <p>Online log: Assertion describing the problem.</p> <p>Server state: Offline.</p> <p>User action: Correct the permissions on the chunk path mentioned in the specific message. Try the operation again. If the operation fails again, note all circumstances and contact IBM Software Support.</p>

Table C-3. Event Alarms (continued)

ID	Severity	Messages	Explanation
Class ID: 4 7 Event ID: 7018	4	Class message: Database server initialization failure Specific message: The chunk ' <i>chunk_number</i> ' must have READ/WRITE permissions for owner and group (660).	The database server cannot start because the permissions on a chunk path are not correct. Online log: Assertion describing the problem. Server state: Offline. User action: Correct the permissions on the chunk path mentioned in the specific message. Try the operation again. If the operation fails again, note all circumstances and contact IBM Software Support.
Class ID: 4 7 Event ID: 7019	4	Class message: Database server initialization failure Specific message: Memory allocation error.	The database server cannot start because it failed to allocate enough memory. Online log: Server state: Offline. User action: Ensure that enough memory is available for the configuration you have specified for the database server. Try the operation again. If the operation fails again, note all circumstances and contact IBM Software Support.
Class ID: 4 7 Event ID: 7020	4	Class message: Database server initialization failure Specific message: The chunk ' <i>chunk_number</i> ' will not fit in the space specified.	The database server cannot start because there is insufficient space to create the specified chunk. Online log: Assertion describing the problem. Server state: Offline. User action: Specify a smaller size for the chunk or free additional space for the chunk.
Class ID: 4 7 Event ID: 7021	4	Class message: Database server initialization failure Specific message: <i>device_name</i> : write failed, file system is full.	The database server cannot start because the file system does not have free space. Online log: Assertion describing the problem. Server state: Offline. User action: Ensure the file system mentioned in the specific message has enough space. Retry the original operation. If the operation fails again, note all circumstances and contact IBM Software Support.

Table C-3. Event Alarms (continued)

ID	Severity	Messages	Explanation
Class ID: 7 Event ID: 7022	3	Class message: Database server initialization failure Specific message: An error occurred while the database server was creating the SMI database.	
Class ID: 7 Event ID: 7023	4	Class message: Database server initialization failure Specific message: Unable to create boot strap config file - 'file_name'	The database server cannot start because it could not create a configuration file. Online log: Assertion describing the error. Server state: Offline. User action: Examine the online log for more information and fix the problem. The problem might be incorrect permissions on a directory. Retry the original operation. If the operation fails again, note all circumstances and contact IBM Software Support.
Class ID: 7 Event ID: 7024	3	Class message: Database server initialization failure Specific message: 'sysmaster' database will not be built/checked	
Class ID: 7 Event ID: 7025	3	Class message: Database server initialization failure Specific message: WARNING! Physical Log size <i>size</i> is too small. Physical Log overflows may occur during peak activity. Recommended minimum Physical Log size is <i>number</i> times maximum concurrent user threads.	
Class ID: 7 Event ID: 7026	3	Class message: Database server initialization failure Specific message: WARNING! Logical log layout may cause <u>__ISN__</u> to get into a locked state. Recommended smallest logical log size is <i>number</i> times maximum concurrent user threads.	

Table C-3. Event Alarms (continued)

ID	Severity	Messages	Explanation
Class ID: 3 7 Event ID: 7027	3	Class message: Database server initialization failure Specific message: WARNING! Buffer pool size may cause __ISN__ to get into a locked state. Recommended minimum buffer pool size is <i>number</i> times maximum concurrent user threads.	
Class ID: 3 7 Event ID: 7028	3	Class message: Database server initialization failure Specific message: Checkpoint log record may not fit into the logical log buffer. Recommended minimum value for LOGBUFF is <i>size</i> .	
Class ID: 3 7 Event ID: 7029	3	Class message: Database server initialization failure Specific message: Temp transaction not NULL.	
Class ID: 9 9 Event ID: 9001	4	Class message: Physical recovery failure Specific message: Physical log recovery error	The physical recovery of the database server failed. Online log: Assertion failure with a description of the problem. Server state: Online. User action: Retry the operation or restore from a backup.
Class ID: 10 10 Event ID: 10001	3 or 4	Class message: Logical recovery failure Specific message: Rollback error <i>error_number</i>	Logical recovery failed because the database server could not roll back a transaction. Online log: Assertion with details of the error and the log or log record where the problem occurred. Server state: Online or offline, depending on the error. User action: Examine the online log file for more information and run any recommended commands, such as an oncheck command. Retry the original operation. If the operation fails again, note all circumstances and contact IBM Software Support.

Table C-3. Event Alarms (continued)

ID	Severity	Messages	Explanation
Class ID: 10 Event ID: 10002	4	Class message: Logical recovery failure Specific message: Logical Recovery ABORTED.	The logical recovery of the database server failed. Online log: Assertion warning with information about the log record. Assertion failure with information about the log record if the failure is associated with a critical dbspace. Server state: Online if the dbspace is not critical. Offline if the dbspace is critical. User action: Examine the online log to determine the appropriate action, for example, you might need to restart the warm restore.
Class ID: 10 Event ID: 10003	4	Class message: Logical recovery failure Specific message: Log record (<i>log_subsystem:log_type</i>) in log <i>log_number</i> , offset <i>log_position</i> was not rolled back	Logical recovery encountered an internal error while rolling back a transaction. Online log: Message describing the log record. Server state: Online. User action: Examine the online log and determine the appropriate action, for example, resubmit the transaction.
Class ID: 10 Event ID: 10004	3	Class message: Logical recovery failure Specific message: Logical Logging error for ' <i>log_subsystem:log_type</i> ' in ' <i>object</i> '	
Class ID: 10 Event ID: 10005	4	Class message: Logical recovery failure Specific message: An internal error occurred while trying to apply the log records during logical log recovery.	Logical recovery failed. Online log: Assertion warning with information about the log record. Server state: Depends on the failure. User action: Examine the online log and determine the appropriate action, for example, restart the warm restore.
Class ID: 10 Event ID: 10006	3 or 4	Class message: Logical recovery failure Specific message: An internal error occurred when the database server tried to find the file descriptor for the tblspace.	Logical recovery failed because the database server could not find an internal file descriptor for a partition. Online log: Assertion indicating for which table the error occurred and instructions to run the oncheck command. Server state: Online. User action: Run the oncheck -cDI command for the table mentioned in the online log or for the database.

Table C-3. Event Alarms (continued)

ID	Severity	Messages	Explanation
Class ID: 11 Event ID: 11001	3	Class message: Cannot open chunk: ' <i>pathname</i> ' Specific message: Cannot Open Mirror Chunk ' <i>chunk_number</i> ', errno = <i>error_number</i>	
Class ID: 11 Event ID: 11002	3	Class message: Cannot open chunk: ' <i>pathname</i> ' Specific message: Cannot Open Primary Chunk ' <i>chunk_number</i> ', errno = <i>error_number</i>	
Class ID: 12 Event ID: 12001	3	Class message: Cannot open dbspace: ' <i>dbspace_name</i> ' Specific message: ERROR: DBspace <i>dbspace_name</i> not found among table <i>table_name</i> fragments.	
Class ID: 13 Event ID: 13001	2	Class message: Performance improvement possible Specific message: The number of configured CPU poll threads exceeds number of CPU VPs specified in 'VPCLASS cpu'. NETTYPE ' <i>protocol</i> ' poll threads started on NET VPs.	<p>The database server detected a configuration mismatch between the number of CPU virtual processors and the number of requested CPU poll threads during server initialization.</p> <p>Online log: Performance warning about the configuration mismatch. The database server uses NET virtual processors instead.</p> <p>Server state: Online.</p> <p>User action: Check the configuration of the server.</p>
Class ID: 13 Event ID: 13002	2	Class message: Performance improvement possible Specific message: Transaction table overflow due to parallel recovery.	<p>An internal structure is not large enough to process the logical log. The database server will postpone the log processing until more space exists within the structure.</p> <p>Online log: Warning message indicating that the transaction processing was delayed.</p> <p>Server state: Online.</p> <p>User action: None.</p>
Class ID: 14 Event ID: 14001	3	Class message: Database failure. ' <i>dbname</i> ' Specific message: " <i>dbname</i> " - Error <i>error_number</i> during logging mode change.	

Table C-3. Event Alarms (continued)

ID	Severity	Messages	Explanation
Class ID: 15 Event ID: 15001	3	Class message: High-Availability Data-Replication failure Specific message: DR: Turned off on secondary server	
Class ID: 15 Event ID: 15002	3	Class message: High-Availability Data-Replication failure Specific message: DR: Turned off on primary server	
Class ID: 15 Event ID: 15003	3	Class message: High-Availability Data-Replication failure Specific message: DR: Cannot connect to secondary server	
Class ID: 15 Event ID: 15004	3	Class message: High-Availability Data-Replication failure Specific message: DR: Received connection request from remote server when DR is not Off [Local type: <i>type</i> , Current state: <i>state</i>] [Remote type: <i>type</i>]	
Class ID: 15 Event ID: 15005	3	Class message: High-Availability Data-Replication failure Specific message: DR: Received connection request before physical recovery completed.	
Class ID: 15 Event ID: 15006	3	Class message: High-Availability Data-Replication failure Specific message: DR: Local and Remote server type and/or last change (LC) incompatible [Local type: <i>type</i> , LC: <i>type</i>] [Remote type: <i>type</i> , LC: <i>type</i>]	

Table C-3. Event Alarms (continued)

ID	Severity	Messages	Explanation
Class ID: 16 Event ID: 16001	2	Class message: Backup completed: 'dbspace_list' Specific message: Archive on <i>dbspace_list</i> completed without being recorded.	An archive completed, but the server detected corrupted pages during the archive. Online log: Message indicating that the backup is complete but that corrupted pages have been detected. Server state: Online. User action: Do not use this backup. Use an earlier backup to immediately restore the bad chunks.
Class ID: 16 Event ID: 16002	2	Class message: Backup completed: 'dbspace_list' Specific message: Archive on <i>dbspace_list</i> Completed with <i>number</i> corrupted pages detected.	An archive completed, but the server detected corrupted pages during the archive. Online log: Message indicating that the backup is complete but that corrupted pages have been detected. Server state: Online. User action: Do not use this backup. Use an earlier backup with 0 bad pages to immediately restore the bad chunks.
Class ID: 16 Event ID: 16003	2	Class message: Backup completed: 'dbspace_list' Specific message: Archive on <i>dbspace_list</i> Completed	An archive completed for the dbspaces listed. Online log: Message indicating that the backup is complete for the dbspaces listed. Server state: Online. User action: None.
Class ID: 17 Event ID: 17001	4	Class message: Backup aborted: 'dbspace_list' Specific message: Archive detects that page <i>chunk_number:page_offset</i> is corrupt.	The database server detected corruption and stopped the backup. Online log: Assertion describing the problem. Server state: Online. User action: Examine the online log for information about the corruption. Try the operation again. If the operation fails again, note all circumstances and contact IBM Software Support.
Class ID: 17 Event ID: 17002	3	Class message: Backup aborted: 'dbspace_list' Specific message: Page %d:%d of partition <i>partition_number</i> not archived.	

Table C-3. Event Alarms (continued)

ID	Severity	Messages	Explanation
Class ID: 18 Event ID: 18001	2	Class message: Log backup completed: <i>log_number</i> Specific message: Logical Log <i>log_number</i> - Backup Completed	The logical log was backed up. Online log: Message identifying the log number of the backed up logical log. Server state: Online. User action: None.
Class ID: 19 Event ID: 19001	3	Class message: Log backup aborted: <i>log_number</i> Specific message: Logical Log <i>log_number</i> - Backup Aborted <i>message</i>	
Class ID: 20 Event ID: 20001	3	Class message: Logical logs are full—backup is needed Specific message: Logical Log Files are Full -- Backup is Needed	
Class ID: 20 Event ID: 20002	3	Class message: Logical logs are full—backup is needed Specific message: Waiting for Next Logical Log File to be Freed	
Class ID: 20 Event ID: 20003	3	Class message: Logical logs are full—backup is needed Specific message: Logical Log Files are almost Full -- Backup is Needed. In Data replication scenario, this could block failure-recovery of the paired server.	
Class ID: 21 Event ID: 21001	3	Class message: Database server resource overflow: ' <i>resource_name</i> ' Specific message: Archive arcbu_next_tbuf() – Buffer Overflow	
Class ID: 21 Event ID: 21002	3	Class message: Database server resource overflow: ' <i>resource_name</i> ' Specific message: Archive tcp_logbu_hdr() – Buffer Overflow	

Table C-3. Event Alarms (continued)

ID	Severity	Messages	Explanation
Class ID: 21 Event ID: 21003	3	Class message: Database server resource overflow: <i>'resource_name'</i> Specific message: Archive tcp_logbu_trl() – Buffer Overflow	
Class ID: 21 Event ID: 21004	2 or 5	Class message: Database server resource overflow: <i>'resource_name'</i> Specific message: Physical log file overflow	For severity 5, the physical log file is full and needs to overflow. If this happens during recovery, the database server attempts to extend the physical log. Online log: Assertion failure if the database server is either not in recovery or is unable to extend the physical log. Assertion warning if the database server is in recovery and extends the physical log. Server State: Offline. User action: None.
Class ID: 21 Event ID: 21005	3	Class message: Database server resource overflow: <i>'resource_name'</i> Specific message: Lock table overflow - user id %d, session id %d	
Class ID: 21 Event ID: 21006	5	Class message: Database server resource overflow: <i>'resource_name'</i> Specific message: Logical log buffer overflow detected	The database server shut down because the logical log buffer is full. Online log: Assertion failure with the log record size and the buffer size. Server State: Offline. User action: Increase the value of the LOGBUFF configuration parameter in the onconfig file. Start the database server.
Class ID: 21 Event ID: 21007	3	Class message: Database server resource overflow: <i>'resource_name'</i> Specific message: Llog logbu_logfile() – Buffer Overflow	
Class ID: 21 Event ID: 21008	3	Class message: Database server resource overflow: <i>'resource_name'</i> Specific message: Llog logbu_bpage() – Buffer Overflow	

Table C-3. Event Alarms (continued)

ID	Severity	Messages	Explanation
Class ID: 21 Event ID: 21009	3	Class message: Database server resource overflow: <i>'resource_name'</i> Specific message: Unable to allocate a user thread for user id <i>user_ID</i>	
Class ID: 21 Event ID: 21010	3	Class message: Database server resource overflow: <i>'resource_name'</i> Specific message: Unable to allocate a transaction for user id <i>user_ID</i> , session id <i>session_ID</i>	
Class ID: 22 Event ID: 22001	3	Class message: Long transaction detected Specific message: Blocking on XA transaction, tx <i>transaction_number</i> , till it is cleaned up.	
Class ID: 22 Event ID: 22002	3	Class message: Long transaction detected Specific message: Continuing Long Transaction (for COMMIT); tx:	
Class ID: 22 Event ID: 22003	3	Class message: Long transaction detected Specific message: Aborting Long Transaction: tx:	
Class ID: 23 Event ID: 23001	2	Class message: Logical log <i>'number'</i> complete Specific message: Logical Log <i>log_number</i> Complete, timestamp: <i>timestamp</i> .	The logical log is full, and no more transactions can be written to it. Online log: Message indicating that the logical log is full. Server state: Online. User action: None.
Class ID: 24 Event ID: 24001	3	Class message: Unable to allocate memory Specific message: Generic unique event id when the server failed to allocate memory for starting a new thread.	

Table C-3. Event Alarms (continued)

ID	Severity	Messages	Explanation
Class ID: 24	3	Class message: Unable to allocate memory	
Event ID: 24002		Specific message: Warning: unable to allocate requested big buffer of size <i>size</i>	
Class ID: 24	3	Class message: Unable to allocate memory	
Event ID: 24003		Specific message: The database server tried to allocate a shared memory virtual segment before it was actually needed, in accordance with the setting of the SHMVIRT_ALLOCSEG configuration parameter - but the segment could not be added. Next failure message will be printed in 30 minutes.	
Class ID: 24	3	Class message: Unable to allocate memory	
Event ID: 24004		Specific message: out of message shared memory	
Class ID: 24	3	Class message: Unable to allocate memory	
Event ID: 24005		Specific message: out of message shared memory	
Class ID: 24	3	Class message: Unable to allocate memory	
Event ID: 24006		Specific message: out of virtual shared memory	
Class ID: 24	3	Class message: Unable to allocate memory	
Event ID: 24007		Specific message: No memory available for page cleaners	
Class ID: 24	3	Class message: Unable to allocate memory	
Event ID: 24008		Specific message: kysearch(): Memory allocation error	

Table C-3. Event Alarms (continued)

ID	Severity	Messages	Explanation
Class ID: 24 Event ID: 24009	3	Class message: Unable to allocate memory Specific message: Lock table overflow - user id <i>user_ID</i> , session id <i>session_ID</i>	
Class ID: 24 Event ID: 24010	3	Class message: Unable to allocate memory Specific message: Unable to allocate a user thread for user id <i>user_ID</i>	
Class ID: 24 Event ID: 24011	3	Class message: Unable to allocate memory Specific message: Unable to allocate a transaction for user id <i>user_ID</i> , session id <i>session_ID</i>	
Class ID: 25 Event ID: 25001	2	Class message: Internal subsystem initialized: ' <i>message</i> ' (starts the optical subsystem) Specific message: Optical Subsystem is running.	The database server initialized the Optical Subsystem. Online log: Message indicating that the Optical Subsystem is running. Server state: Online. User action: None.
Class ID: 26 Event ID: 26001	3	Class message: Dynamically added log file <i>logid</i> Specific message: Dynamically added log file <i>logid</i> to DBspace <i>dbspace_name</i>	
Class ID: 27 Event ID: 27001	4	Class message: Log file required Specific message: ALERT: The oldest logical log (<i>log_number</i>) contains records from an open transaction (<i>transaction_number</i>). Logical logging will remain blocked until a log file is added. Add the log file with the onparams -a command, using the -i (insert) option, as in: onparams -a -d <i>dbspace</i> -s <i>size</i> -i Then complete the transaction as soon as possible.	The database server needs an additional log file to continue processing. Online log: ALERT: The oldest logical log (<i>log_number</i>) contains records from an open transaction (<i>transaction_number</i>). Logical logging will remain blocked until a log file is added. Add the log file with the onparams -a command, using the -i (insert) option, as in: onparams -a -d <i>dbspace</i> -s <i>size</i> -i Then complete the transaction as soon as possible. Server state: Online. User action: Add a new logical log.

Table C-3. Event Alarms (continued)

ID	Severity	Messages	Explanation
Class ID: 28 Event ID: 28001	4	Class message: No space for log file Specific message: ALERT: Because the oldest logical log (<i>log_number</i>) contains records from an open transaction (<i>transaction_number</i>), the server is attempting to dynamically add a log file. But there is no space available. Please add a DBspace or chunk. Then complete the transaction as soon as possible.	The database server cannot dynamically add an additional logical log file because not enough space is available. Online log: Assertion warning indicating that there is not enough space available for an additional logical log file. Server state: Online. User action: Add a new logical log file or additional space.
Class ID: 28 Event ID: 28002	4	Class message: No space for log file Specific message: Warning - Enterprise Replication is attempting to dynamically add a log file. But there is no space available. The replay position may overrun.	The database server cannot dynamically add an additional logical log file because not enough space is available. Online log: Assertion warning indicating that there is not enough space available for an additional logical log file. Server state: Online. User action: Add a new logical log file or additional space.
Class ID: 29 Event ID: 29001	2	Class message: Internal subsystem: <i>subsystem</i> Specific message: Skipped existing audit trail files <i>file_name</i> to <i>file_name</i> .	The auditing subsystem needs to change to a new output file. Online log: Message indicating that the audit file changed, skipping over existing files. Server state: Online. User action: None.
Class ID: 30 - 39	2, 3, or 4	Enterprise Replication events. See Enterprise Replication event alarms.	
Class ID: 40 Event ID: 40001	3	Class message: RSS alarm Specific message: RSS <i>server_name</i> added	
Class ID: 40 Event ID: 40002	3	Class message: RSS alarm Specific message: Password for RSS Source <i>server_name</i> changed	

Table C-3. Event Alarms (continued)

ID	Severity	Messages	Explanation
Class ID: 40 Event ID: 40003	3	Class message: RSS alarm Specific message: RSS <i>server_name</i> deleted	
Class ID: 40 Event ID: 40004	3	Class message: RSS alarm Specific message: RSS <i>server_name</i> log replay position is falling too far behind RSS Source	
Class ID: 40 Event ID: 40005	3	Class message: RSS alarm Specific message: RSS <i>server_name</i> is not acknowledging log transmission	
Class ID: 40 Event ID: 40006	3	Class message: RSS alarm Specific message: Error receiving a buffer from RSS <i>server_name</i> - shutting down	
Class ID: 41 Event ID: 41001	3	Class message: SDS alarm Specific message: ERROR: Removing SDS Node <i>server_name</i> has timed out - removing	
Class ID: 42 Event ID: 42001	1	Class message: Event occurred	<p>The database server encountered an error while validating the tablespace page.</p> <p>Online log: Assertion warning with details of the table.</p> <p>Server state: Online.</p> <p>User action: Examine the online log to determine which database.owner.tablename the issue occurred on. Run the oncheck -pt command on the table. Correct any errors identified by the oncheck utility and retry the operation. If the operation fails again, note all circumstances and contact IBM Software Support.</p>

Table C-3. Event Alarms (continued)

ID	Severity	Messages	Explanation
Class ID: 43 Event ID: 43001	3	Class message: Connection Manager alarm Specific message: CM:Session for Connection manager <i>name</i> terminated abnormally	
Class ID: 43 Event ID: 43002	3	Class message: Connection Manager alarm Specific message: The FOC setting <i>FOC_String</i> for Connection Manager <i>CM_Name</i> does not match the FOC setting for the other Connection Managers that are configured to arbitrate failover for the cluster. If this Connection Manager becomes the active arbitrator, its FOC will not match the previous FOC policy.	
Class ID: 44 Event ID: 44001	3	Class message: DBSpace is full: <i>dbspace_name</i> Specific message: WARNING: <i>dbspace_type dbspace_name</i> is full	
Class ID: 45 Event ID: 45001	3	Class message: partition ' <i>partition_name</i> ': no more extents Specific message: Partition ' <i>partition_name</i> ': No more extents	
Class ID: 46 Event ID: 46001	3	Class message: partition ' <i>partition_name</i> ': no more pages Specific message: Partition ' <i>partition_name</i> ': No more pages	
Class ID: 47 - 71	3 or 4	Enterprise Replication events. See Enterprise Replication event alarms.	
Class ID: 72 Event ID: 72001	2	Class message: Audit trail is switched to a new file. Specific message: Audit trail switched to <i>file_name</i>	The auditing subsystem is switching to a new output file. Online log: Message providing the file name of the new output file. Server state: Online. User action: None.
Class ID: 73-77	3 or 4	Enterprise Replication events. See Enterprise Replication event alarms.	

Table C-3. Event Alarms (continued)

ID	Severity	Messages	Explanation
Class ID: 78 Event ID: 78001	3	Class message: The storage pool is empty. Specific message: Warning: The storage pool is out of space.	
Class ID: 79 Event ID: 79001	3	Class message: Dynamically added chunk <i>chunk_name</i> to space Specific message: Dynamically added chunk <i>chunk_name</i> to space ' <i>space_name</i> ' Path: <i>path</i> , offset <i>offset_number</i> kilobytes Size: <i>size</i> kilobytes	
Class ID: 80		Not currently in use.	
Class ID: 81 Event ID: 81001	4	Class message: Logical log file or dbspace corruption detected during backup. Loguniq or Dbspace id: <i>ID</i> . Specific message: Log Backup detected a corrupted logical log file. Expected loguniq:pagenum <i>log_number:page_number</i> Actual loguniq:pagenum <i>log_number:page_number</i> Log backup continuing but the log backup cannot be used to restore a server. You should run oncheck and take a level 0 archive.	A backup failed because the database server detected corruption in the logical log file or dbspace. Online log: Assertion warning. Server state: Online. User action: Perform a new level-0 backup.
Class ID: 82 Event ID: 82001	3	Class message: session <i>ID (thread)</i> network write operation has been blocked for at least 30 minutes, which might indicate an operating system problem Specific message: session <i>ID (thread)</i> network write operation has been blocked for at least 30 minutes, which might indicate an operating system problem	

Table C-3. Event Alarms (continued)

ID	Severity	Messages	Explanation
Class ID: 83 Event ID: 83001	3	Class message: SDS: Failover aborted - detected primary server is still active. Specific message: SDS: Failover aborted - detected primary server is still active.	

Severity 5 event alarms

Severity 5 event alarms indicate that the database server has failed.

Table C-4. Severity 5 event alarms

ID	Messages	Explanation
Class ID: 6 Event ID: 6033	Class message: Internal subsystem failure: 'message' Specific message: Cache read error	The database server shut down after encountering an error while reading an internal cache. Online log: Assertion Failure. Server State: Offline. User action: Start the database server and try the operation again. If the operation fails again, note all circumstances and contact IBM Software Support.
Class ID: 6 Event ID: 6041	Class message: Internal subsystem failure: 'message' Specific message: An internal error was detected by the Buffer Manager in the database server.	The database server buffer manager encountered an internal error and either shut down or corrected the problem. Online log: Assertion warning or an assertion failure with a description of the operation being performed at the time of the error. Typically, an assertion warning shows that the error was internally corrected. Server State: Offline if the error was unrecoverable. Online if the error was corrected. User action: If the error was unrecoverable, start the database server and try the operation again. If the operation fails again, note all circumstances and contact IBM Software Support. No action is required if the error was internally corrected by the database server.

Table C-4. Severity 5 event alarms (continued)

ID	Messages	Explanation
<p>Class ID: 6</p> <p>Event ID: 6042</p>	<p>Class message: Internal subsystem failure: 'message'</p> <p>Specific message: An internal error was reported by the database server when it detected an inconsistency with the internal buffer queues.</p>	<p>The database server detected an inconsistency during the processing of internal buffer queues and either shut down or corrected the problem.</p> <p>Online log: Assertion warning or an assertion failure with a description of the operation being performed at the time of the error. Typically, an assertion warning shows that the error was internally corrected.</p> <p>Server State: Offline if the error was unrecoverable. Online if the error was corrected.</p> <p>User action: If the error was unrecoverable, start the database server and try the operation again. If the operation fails again, note all circumstances and contact IBM Software Support. No action is required if the error was internally corrected by the database server.</p>
<p>Class ID: 6</p> <p>Event ID: 6045</p>	<p>Class message: Internal subsystem failure: 'message'</p> <p>Specific message: Logical logging error for 'object' in 'space'</p>	<p>The database server shut down because of an error while processing logical logs.</p> <p>Online log: Assertion failure with a description of the operation and logical log information.</p> <p>Server State: Offline.</p> <p>User action: Start the database server. If the operation fails again, note all circumstances and contact IBM Software Support.</p>
<p>Class ID: 6</p> <p>Event ID: 6049</p>	<p>Class message: Internal subsystem failure: 'message'</p> <p>Specific message: Lock types <i>lock_type</i> and <i>lock_type</i> should never be merged</p>	<p>The database server shut down after attempting to merge incompatible locks.</p> <p>Online log: Assertion failure with the lock types that the database server was attempting to merge.</p> <p>Server State: Offline.</p> <p>User action: Start the database server. If the operation fails again, note all circumstances and contact IBM Software Support.</p>

Table C-4. Severity 5 event alarms (continued)

ID	Messages	Explanation
<p>Class ID: 6</p> <p>Event ID: 6050</p>	<p>Class message: Internal subsystem failure: 'message'</p> <p>Specific message: An internal error was reported by the database server when it detected some corruption in the lock free list chain.</p>	<p>The database server shut down after detecting corruption of an internal structure that manages an internal list of free locks.</p> <p>Online log: Assertion failure.</p> <p>Server State: Offline.</p> <p>User action: Start the database server. If the operation fails again, note all circumstances and contact IBM Software Support.</p>
<p>Class ID: 6</p> <p>Event ID: 6060</p>	<p>Class message: Internal subsystem failure: 'message'</p> <p>Specific message: Thread exited with <i>number</i> buffers held</p>	<p>The database server shut down after detecting that a thread is holding one or more buffers.</p> <p>Online log: Assertion failure with the number of buffers being held by the thread.</p> <p>Server State: Offline.</p> <p>User action: Bring the database server online. If the operation fails again, note all circumstances and contact IBM Software Support.</p>
<p>Class ID: 6</p> <p>Event ID: 6067</p>	<p>Class message: Internal subsystem failure: 'message'</p> <p>Specific message: A fatal internal error (Recursive exception) has caused the database server processes to terminate unexpectedly.</p>	<p>The database server detected recursive calls to exception handling and immediately shut down to avoid an infinite loop.</p> <p>Online log: Assertion failure.</p> <p>Server State: Offline.</p> <p>User action: Start the database server. If the operation fails again, note all circumstances and contact IBM Software Support.</p>
<p>Class ID: 6</p> <p>Event ID: 6068</p>	<p>Class message: Internal subsystem failure: 'message'</p> <p>Specific message: A fatal internal error (Internal exception) has caused the database server processes to terminate unexpectedly.</p>	<p>The database server shut down due to an unrecoverable internal error.</p> <p>Online log: Assertion failure with information about the exception that caused the problem.</p> <p>Server State: Offline.</p> <p>User action: Start the database server. Look at the exception information in the assertion failure file. If the exception relates to a user-defined routine, investigate and correct the user-defined routine. If the operation fails again, note all circumstances and contact IBM Software Support.</p>

Table C-4. Severity 5 event alarms (continued)

ID	Messages	Explanation
Class ID: 6 Event ID: 6069	Class message: Internal subsystem failure: 'message' Specific message: A fatal internal error (Master daemon died) has caused the database server processes to terminate unexpectedly.	<p>The master daemon oninit process stopped and the database server shut down. This error can be caused by the termination of operating system processes.</p> <p>Online log: Assertion failure.</p> <p>Server State: Offline.</p> <p>User action: Start the database server. Be careful when terminating operating system processes.</p>
Class ID: 6 Event ID: 6070	Class message: Internal subsystem failure: 'message' Specific message: A fatal internal error (VP died) has caused the database server processes to terminate unexpectedly.	<p>An oninit process stopped and the database server shut down. This error can be caused by the termination of operating system processes.</p> <p>Online log: Assertion failure.</p> <p>Server State: Offline.</p> <p>User action: Start the database server. Be careful when terminating operating system processes.</p>
Class ID: 6 Event ID: 6071	Class message: Internal subsystem failure: 'message' Specific message: ERROR: cannot fork secondary Server thread (MACH11 Shutdown)	<p>The secondary server shut down but was unable to create a thread to shut down normally.</p> <p>Online log: DR: Shutting down the server. ERROR: can not fork secondary Server thread (MACH11 Shutdown) Can not run onmode -ky PANIC: Attempting to bring system down.</p> <p>Server State: Offline.</p> <p>User action: None.</p>
Class ID: 6 Event ID: 6075	Class message: Internal subsystem failure: 'message' Specific message: A fatal internal error (KAIO) has caused the database server processes to terminate unexpectedly.	<p>The database server shut down because of an error in the KAIO subsystem.</p> <p>Online log: Assertion failure with the specific operation that failed.</p> <p>Server State: Offline.</p> <p>User action: Start the database server. If the operation fails again, note all circumstances and contact IBM Software Support.</p>

Table C-4. Severity 5 event alarms (continued)

ID	Messages	Explanation
Class ID: 6 Event ID: 6500	Generic event for when the database server terminates unexpectedly due to an internal error condition.	An internal error occurred and the database server shut down. Online log: Assertion failure. Server State: Offline. User action: Start the database server. Examine the assertion failure file for more information about what happened. If possible, fix any problems identified and try the operation again. If the operation fails again, note all circumstances and contact IBM Software Support.
Class ID: 21 Event ID: 21004	Class message: Database server resource overflow: <i>'resource_name'</i> Specific message: Physical log file overflow	The physical log file is full and needs to overflow. If this happens during recovery, the database server attempts to extend the physical log. Online log: Assertion failure if the database server is either not in recovery or is unable to extend the physical log. Assertion warning if the database server is in recovery and extends the physical log. Server State: Offline. User action: None.
Class ID: 21 Event ID: 21006	Class message: Database server resource overflow: <i>'resource_name'</i> Specific message: Logical log buffer overflow detected	The database server shut down because the logical log buffer is full. Online log: Assertion failure with the log record size and the buffer size. Server State: Offline. User action: Increase the value of the LOGBUFF configuration parameter in the onconfig file. Start the database server.

Connection Manager event alarm IDs

The class ID for event alarms indicates the type of event. The event ID indicates the specific event.

The following table lists event alarm IDs and messages for the Connection Manager.

You can set your alarm program script to capture the Connection Manager class ID and message and initiate corrective actions or notifications.

You can use the values set in the INFORMIXCMNAME and INFORMIXCMCONUNITNAME environment variables when writing an alarm

handler for the Connection Manager. If the Connection Manager raises an event alarm, the Connection Manager instance name is stored in the INFORMIXCMNAME environment variable, and the Connection Manager connection unit name is stored in the INFORMIXCMCONUNITNAME environment variable.

Event alarm messages are written to the Connection Manager log file.



Table C-5. Connection Manager Event Alarms

ID	Severity	Messages	Explanation
Class ID: 1 Event ID: 1001	3	Class message: Specific message: Connection Manager stopped	The Connection Manager has stopped running
Class ID: 1 Event ID: 1002	3	Class message: Specific message: Connection Manager fatal error	The Connection Manager has failed to initialize
Class ID: 2 Event ID: 2001	3	Class message: Specific message: Failover in progress	The Connection Manager failover arbitrator has initiated a failover event
Class ID: 2 Event ID: 2002	3	Class message: Specific message: Failover completed	The Connection Manager failover arbitrator has completed failover
Class ID: 2 Event ID: 2003	3	Class message: Specific message: Failover disabled	The Connection Manager automated failover feature is disabled
Class ID: 3 Event ID: 3001	3	Class message: Specific message: Cannot connect to primary server	The Connection Manager is unable to connect to the primary server
Class ID: 3 Event ID: 3002	3	Class message: Specific message: Lost connection to primary server	The Connection Manager is disconnected from the primary server

Table C-5. Connection Manager Event Alarms (continued)

ID	Severity	Messages	Explanation
Class ID: 4 Event ID: 4001	3	Class message: Specific message: Cannot connect to ER node	The Connection Manager cannot connect to an Enterprise Replication server
Class ID: 4 Event ID: 4002	3	Class message: Specific message: Lost connection to ER node	The Connection Manager has disconnected from an Enterprise Replication server
Class ID: 5 Event ID: 5001	3	Class message: Specific message: Cannot connect to server	The Connection Manager cannot connect to a secondary server in a high-availability cluster
Class ID: 5 Event ID: 5002	3	Class message: Specific message: Lost connection to server	The Connection Manager is disconnected from the secondary servers

Related reference:

-  [INFORMIXCMNAME environment variable \(SQL Reference\)](#)
-  [INFORMIXCMCONUNITNAME environment variable \(SQL Reference\)](#)

Appendix D. Discontinued configuration parameters

The current version of Informix does not use some configuration parameters that were used in earlier versions of the server. This appendix lists the discontinued and obsolete configuration parameters for Informix.

Table D-1 summarizes the discontinued parameters. Although these parameters are still supported, it is recommended that you do not use them. Remove these parameters from the ONCONFIG file before using the VPCLASS parameter.

Table D-1. Discontinued Configuration Parameters

Configuration Parameter	Reference
AFF_NPROCS	"AFF_NPROCS (Discontinued)" on page D-2
AFF_SPROC	"AFF_SPROC (Discontinued)" on page D-2
RA_THRESHOLD	"RA_THRESHOLD configuration parameter (discontinued)" on page D-10
BUFFERS	"BUFFERS (Discontinued)" on page D-3
FAST_RESTART_CKPT_FUZZYLOG	"FAST_RESTART_CKPT_FUZZYLOG (Discontinued)" on page D-4
FAST_RESTART_PHYSLOG	"FAST_RESTART_PHYSLOG (Discontinued)" on page D-4
LRU_MAX_DIRTY	"LRU_MAX_DIRTY (Discontinued)" on page D-6
LRU_MIN_DIRTY	"LRU_MIN_DIRTY (Discontinued)" on page D-6
LRUS	"LRUS (Discontinued)" on page D-7
NOAGE	"NOAGE (Discontinued)" on page D-7
NUMAIOVPS	"NUMAIOVPS (Discontinued)" on page D-8
NUMCPUVPS	"NUMCPUVPS (Discontinued)" on page D-8
PHYSDBS	"PHYSDBS (Discontinued)" on page D-9

Table D-2 summarizes the configuration parameters that are no longer supported.

Table D-2. Obsolete Configuration Parameters

Configuration Parameter	Reference
JDKVERSION	"JDKVERSION (Discontinued)" on page D-5
LBU_PRESERVE	"LBU_PRESERVE (Discontinued)" on page D-5
LOGSMAX	"LOGSMAX (Discontinued)" on page D-5

Related reference:

“BUFFERPOOL configuration parameter” on page 1-36

AFF_NPROCS (Discontinued)

onconfig.std value

0

units Number of CPUs

range of values

0 through number of CPUs in the computer

takes effect

When the database server shuts down and restarts

refer to

- Virtual-processor es, in the chapter on virtual processors and threads in the *IBM Informix Administrator's Guide*
- “AFF_SPROC (Discontinued)”
- “VPCLASS configuration parameter” on page 1-167

On multiprocessor computers that support *processor affinity*, AFF_NPROCS specifies the number of CPUs to which the database server can bind CPU virtual processors. Binding a CPU virtual processor to a CPU causes the virtual processor to run exclusively on that CPU. The database server assigns CPU virtual processors to CPUs in serial fashion, starting with the processor number that AFF_SPROC specifies.

If you specify more CPU virtual processors than there are processors, the database server starts over again at the beginning. For example, if you set AFF_NPROCS to 3 and AFF_SPROCS to 5, the database server assigns two CPU virtual processors to processor 5, two CPU virtual processors to processor 6, and one CPU virtual processor to processor 7.

Important: Use VP instead of AFF_NPROCS to specify the number of CPUs. You cannot use both AFF_NPROCS and VP *cpu* in the same ONCONFIG file.

AFF_SPROC (Discontinued)

onconfig.std value

0

units CPU number

range of values

0 through (AFF_NPROCS - NUMCPUVPS + 1)

takes effect

When the database server shuts down and restarts

refer to

- Virtual-processor classes, in the chapter on virtual processors and threads in the *IBM Informix Administrator's Guide*
- “AFF_NPROCS (Discontinued)”
- “VPCLASS configuration parameter” on page 1-167

On multiprocessor computers that support *processor affinity*, `AFF_SPROC` specifies the CPU, starting with 0, on which the database server starts binding CPU virtual processors to CPUs. The `AFF_NPROCS` parameter specifies the number of CPUs that the database server will use. The `NUMCPUVPS` parameter specifies the number of CPU virtual processors to be started, and the `AFF_SPROC` parameter specifies the CPU on which the first virtual processor is to start. For example, if you assign eight CPUs (`AFF_NPROCS = 8`), and set `NUMCPUVPS` to 3 and `AFF_SPROC` to 5, the database server binds CPU virtual processors to the fifth, sixth, and seventh CPUs.

Important: Use `VPCLASS` instead of `AFF_SPROC` to specify processor affinity. You cannot use both `AFF_SPROC` and `VPCLASS cpu` in the same `ONCONFIG` file.

BUFFERS (Discontinued)

onconfig.std value

UNIX: 5000Windows : 2000

units Number of buffers

range of values

For 32-bit platform on UNIX: with page size equal to 2048 bytes: 100 through 1,843,200 buffers ($1843200 = 1800 * 1024$)

with page size equal to 4096 bytes: 100 through 921,600 buffers ($921,600 = ((1800 * 1024) / 4096) * 2048$)

For 32-bit platform on Windows: 100 through 524,288 buffers ($524,288 = 512 * 1024$)

For 64-bit platforms: 100 through $2^{31}-1$ buffers (For the actual value for your 64-bit platform, see your machine notes. The maximum number of buffers on Solaris is 536,870,912.)

takes effect

When the database server is shut down and restarted

utilities

onstat -b or **-B** (See “**onstat -b** command: Print buffer information for buffers in use” on page 21-25.)

refer to

- Shared-memory buffer pool in the shared-memory chapter of the *IBM Informix Administrator's Guide*
- “`RA_PAGES` configuration parameter” on page 1-116
- Your *IBM Informix Performance Guide*

Note: Information that was specified with the `BUFFERS` configuration parameter prior to Version 10.0 is now specified using the `BUFFERPOOL` configuration parameter. For more information, see “`BUFFERPOOL` configuration parameter” on page 1-36.

`BUFFERS` specifies the maximum number of shared-memory buffers that the database server user threads have available for disk I/O on behalf of client applications. Therefore, the number of buffers that the database server requires depends on the applications. For example, if the database server accesses 15 percent of the application data 90 percent of the time, you need to allocate enough buffers to hold that 15 percent. Increasing the number of buffers can improve system performance.

In general, buffer space should range from 20 to 25 percent of physical memory. It is recommended that you calculate all other shared-memory parameters after you set buffer space (`BUFFERS *system_page_size`) to 20 percent of physical memory.

FAST_RESTART_CKPT_FUZZYLOG (Discontinued)

onconfig.std *value*

The `FAST_RESTART_CKPT_FUZZYLOG` parameter does not need to be in the `onconfig.std` file.

range of values

0 (default) = Disable the flushing of dirty fuzzy pages to the physical log at checkpoint.

1 = Enable the flushing of dirty fuzzy pages to the physical log at checkpoint.

takes effect

At the checkpoint that occurs after the parameter is enabled. If the total number of unflushed, dirty fuzzy pages exceeds 20 percent of the total physical log space, the pages will not be written to the physical log. If server fails after this checkpoint, crash recovery receives no performance benefit.

refer to Information on fast recovery and alternative fast restart recovery options for fuzzy operations in the *IBM Informix Administrator's Guide*.

The `FAST_RESTART_CKPT_FUZZYLOG` parameter and the `FAST_RESTART_PHYSLOG` parameter enable the database server to perform physical logging on fuzzy checkpoints during the roll-forward (log replay) phase of recovery, thus decreasing recovery time. You can use either parameter or both when using fuzzy checkpoints.

The database server must be online when you enable the `FAST_RESTART_CKPT_FUZZYLOG` parameter.

FAST_RESTART_PHYSLOG (Discontinued)

onconfig.std *value*

The `FAST_RESTART_PHYSLOG` parameter does not need to be in the `onconfig.std` file.

range of values

0 (default) = Disable physical logging on fuzzy checkpoints during the roll-forward (log replay) phase of recovery.

1 = Enable physical logging on fuzzy checkpoints during the roll-forward (log replay) phase of recovery, thus decreasing recovery time.

takes effect

Immediately. If the total number of unflushed, fuzzy dirty pages exceeds 20 percent of the total physical log space, the pages will not be written to the physical log. However, if the database server fails before the next checkpoint performs, maximum fast-recovery performance does not occur because the database server did not log all of the fuzzy updates in the checkpoint intervals.

refer to Information on fast recovery and alternative fast restart recovery options for fuzzy operations in the *IBM Informix Administrator's Guide*

The `FAST_RESTART_PHYSLOG` parameter and the `FAST_RESTART_CKPT_FUZZYLOG` parameter enable the database server to perform physical logging on fuzzy checkpoints during the roll-forward (log replay) phase of recovery, thus decreasing recovery time. You can use either parameter or both when using fuzzy checkpoints.

Only use the `FAST_RESTART_PHYSLOG` parameter if the buffer pool is at least 25 percent larger than the physical buffer size. The buffer pool must be large enough to hold the physical log, log pages, and other pages read during recovery. If the buffer pool is not configured correctly, fast recovery performance is compromised.

The extra physical logging that occurs when the database server uses the `FAST_RESTART_PHYSLOG` parameter affects runtime performance. If you do not want to sacrifice runtime performance or if you do not want to increase the buffer size, use the `FAST_RESTART_CKPT_FUZZYLOG` parameter to reduce some recovery time.

After enabling the `FAST_RESTART_PHYSLOG` parameter by setting it to 1, you can initiate fast recovery using the `oninit` utility. Simply execute `oninit` without any options.

The database server must be online when you enable the `FAST_RESTART_PHYSLOG` parameter.

JDKVERSION (Discontinued)

onconfig.std value

1.4

range of values

For this release, the valid values are 1.4, 1.3, and 1.2.

takes effect

When shared memory is initialized

JDKVERSION is the major version of the JDK or JRE release. That is, the version number does not include *x* when the version is JDK 1.4.*x*.

This parameter is required if the number of JVPs (set in `VPCLASS JVP`) is greater than 0.

LBU_PRESERVE (Discontinued)

Informix no longer supports the `LBU_PRESERVE` parameter, which reserves the last logical log for ON-Archive use. ON-Archive, which has been discontinued, was the only utility that required free log space to back up a logical log.

LOGSMAX (Discontinued)

Informix no longer supports the `LOGSMAX` parameter.

`LOGSMAX` specifies the maximum number of logical-log files for a database server instance. The database server requires at least three logical-log files for operation. The maximum number of logical logs is 32,767. The `LOGSMAX` value must be equal to or less than the highest log file number.

LRU_MAX_DIRTY (Discontinued)

onconfig.std *value*
60.00

units Percent

range of values
0 through 100 (fractional values are allowed)

takes effect
When the database server is shut down and restarted

refer to The following topics in the shared-memory chapter of the *IBM Informix Dynamic Server Administrator's Guide*

- LRU queues
- Limiting the number of pages added to the MLRU queues

Note: Information that was specified with the LRU_MAX_DIRTY configuration parameter prior to Version 10.0 is now specified using the BUFFERPOOL configuration parameter. For more information, see "BUFFERPOOL configuration parameter" on page 1-36.

LRU_MAX_DIRTY specifies the percentage of modified pages in the LRU queues at which the queue is cleaned. If a parameter is specified out of the range of values, then the default of 60.00 percent is set.

LRU_MIN_DIRTY (Discontinued)

onconfig.std *value*
50.00

units Percent

range of values
0 through 100 (fractional values are allowed)

takes effect
When the database server is shut down and restarted

refer to The following topics in the shared-memory chapter of the *IBM Informix Dynamic Server Administrator's Guide*:

- LRU queues
- When MLRU cleaning ends

Note: Information that was specified with the LRU_MIN_DIRTY configuration parameter prior to Version 10.0 is now specified using the BUFFERPOOL configuration parameter. For more information, see "BUFFERPOOL configuration parameter" on page 1-36.

LRU_MIN_DIRTY specifies the percentage of modified pages in the LRU queues at which page cleaning is no longer mandatory. Page cleaners might continue cleaning beyond this point under some circumstances. If a parameter is specified out of the range of values, then the default of 50.00 percent is set.

LRUS (Discontinued)

onconfig.std *value*
8

if not present

If MULTIPROCESSOR is set: MAX(4, num_cpu_vps) If MULTIPROCESSOR is not set: 4

units Number of LRU queues

range of values

1 through 128

takes effect

When the database server is shut down and restarted

utilities

onstat -R (see “**onstat -R** command: Print LRU, FLRU, and MLRU queue information” on page 21-207.)

refer to

- LRU queues, in the shared-memory chapter of the *IBM Informix Dynamic Server Administrator's Guide*
- Chapter on configuration effects on memory, in your *IBM Informix Dynamic Server Performance Guide*

Note: Information that was specified with the LRUS configuration parameter prior to Version 10.0 is now specified using the BUFFERPOOL configuration parameter. For more information, see “BUFFERPOOL configuration parameter” on page 1-36.

LRUS specifies the number of LRU (least-recently-used) queues in the shared-memory buffer pool. You can tune the value of LRUS, in combination with the LRU_MIN_DIRTY and LRU_MAX_DIRTY parameters, to control how frequently the shared-memory buffers are flushed to disk.

Setting LRUS too high might result in excessive page-cleaner activity.

NOAGE (Discontinued)

onconfig.std *value*
0

range of values

0 = Use priority aging. 1 = Disable priority aging.

takes effect

When the database server shuts down and restarts

refer to

- Preventing priority aging, in the chapter on virtual processors and threads in the *IBM Informix Administrator's Guide*
- “VPCLASS configuration parameter” on page 1-167

Some operating systems lower the priority of processes as the processes run over a long period of time. NOAGE, when set to 1, disables *priority aging* of CPU virtual processors by the operating system. When NOAGE is set to the default of 0, the operating system might lower the priority of CPU virtual processors, as well as

other processes, as they accumulate processing time. If your operating system supports priority aging, it is recommended that you set NOAGE to 1.

Important: It is recommended that you specify priority aging with the VPCLASS parameter instead of the NOAGE parameter. You cannot use both NOAGE and VPCLASS *cpu* in the same ONCONFIG file.

NUMAIOVPS (Discontinued)

onconfig.std value

None

if not present

If AUTO_AIOVPS is set to 1 (on), the number of AIO VPs initially started is equal to the number of AIO chunks, up to a maximum of 128.

If AUTO_AIOVPS is set to 0 (off), the number of AIO VPs started is equal to the greater of 6 or twice the number of AIO chunks, up to a maximum of 128.

units Number of AIO VPs

range of values

Integer between the value of 1 and 10,000, inclusive

takes effect

When the database server shuts down and restarts

utilities

onmode -p in “onmode -p: Add or remove virtual processors” on page 15-20

refer to

- Asynchronous I/O, in the chapter on virtual processors and threads in the *IBM Informix Administrator's Guide*
- “VPCLASS configuration parameter” on page 1-167

NUMAIOVPS specifies the number of virtual processors of the AIO class to run. Unless kernel asynchronous I/O is implemented, the AIO virtual processors perform all the database server disk I/O, other than I/O to the log files.

Important: It is recommended that you specify the number of AIO VPs with VPCLASS*aio* instead of NUMAIOVPS. You cannot use both NUMAIOVPS and VPCLASS *aio* in the same ONCONFIG file.

UNIX Only:

If your platform has kernel-asynchronous I/O (KAIO) turned on, the database server uses AIO virtual processors to perform I/O only to cooked chunks. The database server uses KAIO to perform all I/O to raw disk space and to the physical and logical logs. For details, see the machine notes.

NUMCPUVPS (Discontinued)

onconfig.std value

1

units Number of CPU VPs

range of values

1 through the number of CPUs

takes effect

When the database server shuts down and restarts

utilities

onmode -p in “onmode -p: Add or remove virtual processors” on page 15-20

refer to

- CPU virtual processors, in the chapter on virtual processors and threads in the *IBM Informix Administrator's Guide*
- “VPCLASS configuration parameter” on page 1-167

NUMCPUVPS specifies the number of virtual processors of the CPU class to run. CPU virtual processors run all threads that start as the result of a connection by a client application, as well as internal threads. In general, allocate only one CPU virtual processor on a single-processor computer or node. On a multiprocessor computer or node, do not allocate more CPU virtual processors than there are CPUs.

Important: It is recommended that you specify the number of CPU virtual processors with VPCLASS *cpu* instead of NUMCPUVPS. You cannot use both NUMCPUVPS and VPCLASS *cpu* in the same ONCONFIG file.

On UNIX, use the **onmode -p -1 CPU** command to decrease the number of CPU VPs. On Windows, you can add a CPU VP, but you cannot subtract it.

PHYSDBS (Discontinued)

onconfig.std *value*

rootdbs

if not present

The dbspace that ROOTNAME specifies

units A dbspace

range of values

Up to 128 bytes. PHYSDBS must be unique, begin with a letter or underscore, and contain only letters, numbers, underscores, or \$ characters.

takes effect

When the database server is initialized

refer to

- “**onparams -p**: Change physical-log parameters” on page 17-3
- Where the physical log is located, in the chapter on what is the physical log in the *IBM Informix Administrator's Guide*
- Changing the physical-log location and size, in the chapter on managing the physical log in the *IBM Informix Administrator's Guide*

PHYSDBS specifies the name of the dbspace that contains the physical log. To reduce disk contention, you can move the physical log to a dbspace other than the root dbspace.

When you initialize disk space (**oninit -i**), the PHYSDBS value must be equal to the ROOTDBS value.

RA_THRESHOLD configuration parameter (discontinued)

Use the RA_THRESHOLD configuration parameter to specify the read-ahead threshold, which is the number of unprocessed data pages in memory that signals the database server to perform the next read-ahead.

onconfig.std *value*
16

if not present
RA_PAGES/2

units Number of data pages

range of values
0 through (RA_PAGES - 1)

takes effect
When the database server is shut down and restarted

RA_THRESHOLD is used with RA_PAGES when the database server reads during sequential scans of data records.

If the value of RA_THRESHOLD is greater than the value of RA_PAGES, RA_THRESHOLD has a value of RA_PAGES/2.

Specifying values that are too large for RA_PAGES and RA_THRESHOLD can result in excessive buffer-caching activity.

Appendix E. Error Messages

This chapter lists nonnumbered messages that are printed in the database server message log and provides corrective actions.

For information on numbered messages and the unnumbered ON-Bar messages, search for the message text in the error messages file, which is located in the subdirectory for your locale under the `$INFORMIXDIR/msg` directory. You can also search *IBM Informix Error Messages* in English at the IBM Informix Information Center at <http://publib.boulder.ibm.com/infocenter/idshelp/v117/index.jsp>.

Some of the messages included below might require you to contact Technical Support staff. Such messages are rarely, if ever, seen at customer locations.

For information on what the message log is, see installing and configuring the database server in the *IBM Informix Administrator's Guide*. For information on specifying the path to the message file, see "MSGPATH configuration parameter" on page 1-100.

How the Messages Are Ordered in This Chapter

Database server message-log messages are arranged in this chapter in alphabetical order, sorted with the following additional rules:

- The time stamp that precedes each message is ignored.
- Letter case is ignored in alphabetization.
- Spaces are ignored.
- Quotation marks are ignored.
- Leading ellipses are ignored.
- The word *the* is ignored if it is the first word in the message.
- Messages that begin with numbers or punctuation symbols appear toward the end of the list in a special section labeled "Messages: Symbols" on page E-48.
- Certain related messages are grouped together, as follows:
 - "Conversion/Reversion Messages" on page E-49
 - "Conversion and Reversion Messages for Enterprise Replication" on page E-61
 - "Dynamic Log Messages" on page E-65
 - "Sbospace Metadata Messages" on page E-67
 - "Truncate Table Messages" on page E-68

A cause and suggested corrective action for a message or group of messages follow the message text.

How to View These Messages

Use one of the following methods to view these messages:

- Online message log
 - To see the messages displayed as they occur, use the `tail -f online.log` command.
- `onstat -m` command

For more information, see “**onstat -l** command: Print physical and logical log information” on page 21-193.

- IBM Informix Server Administrator (ISA)

For more information, see the ISA online help.

To see the error number associated with these unnumbered messages, view the **logmessage** table in the **sysmaster** database:

```
SELECT * FROM logmessage;
```

Message Categories

Four general categories of unnumbered messages exist, although some messages fall into more than one category:

- Routine information
- Assertion-failed messages
- Administrative action needed
- Unrecoverable error detected

Technical Support uses the assertion-failed messages to assist in troubleshooting and diagnostics. The information that they report often falls into the category of *unexpected events* that might or might not develop into problems caught by other error codes. Moreover, the messages are terse and often extremely technical. They might report on one or two isolated statistics without providing an overall picture of what is happening. This information can suggest to technical support possible research paths.

Messages: A-B

Aborting Long Transaction: *tx Oxn*.

Cause

The transaction spans the log space specified by transaction high-watermark (LTXHWM), and the offending long transaction is rolling back.

Action

No additional action is needed. The address of the transaction structure in shared memory is displayed as a hexadecimal value.

Affinitied VP *mm* to phys proc *nn*.

Cause

The database server successfully bound a CPU virtual processor to a physical processor.

Action

None required.

Affinity not enabled for this server.

Cause

You tried to bind your CPU virtual processors to physical processors, but the database server that you are running does not support process affinity.

Action

Set `AFF_NPROCS` to 0, or remove the affinity setting from `VPCLASS`.

Assert Failed: Error from SBSpace cleanup thread.

Cause

The sbspace cleanup thread encountered an error while cleaning up stray smart large objects.

Action

See the action suggested in the message log file.

Most of the time, running `onspaces -cl sbspacename` on the failed sbspace succeeds in cleaning up any stray smart large objects. If you encounter an unrecoverable error, contact Technical Support.

Assert Failed: Short description of what failed Who: Description of user/session/thread running at the time Result: State of the affected database server entity Action: What action the database administrator should take See Also: DUMPDIR/af.uniqid containing more diagnostics.

Cause

This message indicates an internal error.

Action

The `af.uniqid` file in the directory specified by the `ONCONFIG` parameter `DUMPDIR` contains a copy of the assertion-failure message that was sent to the message log, as well as the contents of the current, relevant structures and/or data buffers. The information included in this message is intended for Technical Support.

Begin re-creating indexes deferred during recovery.

Cause

During recovery, indexes to be created are deferred until after recovery completes. This message indicates that the database server deferred re-creating indexes and that it is now creating the indexes. During the time that the database server re-creates the indexes, it locks the affected tables with a shared lock.

Action

None required.

Building 'sysmaster' database requires ~mm pages of logical log. Currently there are nn pages available. Prepare to back up your logs soon.

Cause

You do not currently have the approximate amount of free log space necessary to complete a build of the sysmaster database.

Action

Back up your logs.

Building 'sysmaster' database...

Cause

The database server is building the sysmaster database.

Action

None required.

Messages: C

Cannot Allocate Physical-log File, mm wanted, nn available.

Cause

The database server attempted to initialize shared memory with a physical-log size that exceeds the amount of contiguous space available in the dbspace (specified as PHYSDBS in ONCONFIG). Both quantities of space, wanted and available, are expressed as kilobytes.

Action

You must either reduce the size of the physical log (specified as PHYSFILE in ONCONFIG) or change the location of the physical log to a dbspace that contains adequate contiguous space to accommodate the physical log.

Cannot alter a table which has associated violations table.

Cause

The user tried to add, drop, or modify a column in a table that has a violations table associated with it.

Action

Do not change the columns in the user table.

Cannot change to mode.

Cause

Some error during fast or full recovery has prevented the system from changing to online or quiescent mode.

Action

See previous messages in the log file for information.

Cannot Commit Partially Complete Transactions.

Cause

Transactions that drop tables or indexes do not perform the drop until a COMMIT statement is processed (with a few exceptions). In these cases, a *beginning commit* log record is written, followed by the usual commit log record. If the database server fails in between the two, the fast recovery process attempts to complete the commit the next time that you initialize the database server.

If this completion of the commit fails, the database server generates the preceding message.

Action

To determine if you need to take action, examine the logical log as described in Chapter 5, "Interpreting Logical-Log Records," on page 5-1.

Cannot create a user-defined VP class with 'SINGLE_CPU_VP' non-zero.

Cause

SINGLE_CPU_VP is set to nonzero, and **onmode** was used to create a user-defined VP class.

Action

If user-defined VP classes are necessary, stop the database server, change SINGLE_CPU_VP to zero, and restart the database server.

Cannot create violations/diagnostics table.

Cause

The user issued a START VIOLATIONS TABLE statement for a target table. The database server cannot create the violations table for this target table. Any of the following situations might be the reason for this failure:

- The target table already has a violations table.
- You specified an invalid name for the violations table in the START VIOLATIONS TABLE statement. For example, if you omit the USING clause from the statement and if the number of characters in the target table plus four characters is longer than the maximum identifier length, the generated names of the violations table exceed the maximum identifier length.
- You specified a name for the violations table in the START VIOLATIONS TABLE statement that match the names of existing tables in the database.
- The target table contains columns with the names **informix_tupleid**, **informix_optype**, or **informix_reowner**. Because these column names duplicate the **informix_tupleid**, **informix_optype**, or **informix_reowner** columns in the violations table, the database server cannot create the violations table.
- The target table is a temporary table.
- The target table is serving as a violations table for some other table.

- The target table is a system catalog table.

Action

To resolve this error, perform one of the following actions:

- If the violations table name was invalid, specify a unique name for the violations table in the USING clause of the START VIOLATIONS TABLE statement.
- If the target table contains columns with the names **informix_tupleid**, **informix_optype**, or **informix_reowner**, rename them to something else.
- Choose a permanent target table that is not a system catalog table or a violations table for some other table.

Cannot insert from the violations table to the target table.

Cause

The user has issued a statement that attempts to insert rows from the violations table into the target table. For example, the user enters the following invalid statement:

```
INSERT INTO mytable SELECT * FROM mytable_vio;
```

Also, if the target table has filtering-mode constraints, you receive this error.

Action

To recover from this error, perform the following actions:

- Do not use filtering constraints.
- Stop the violations table.
- Insert rows from the violations table into a temporary table, and then insert rows from the temporary table into the target table.

Cannot modify/drop a violations/diagnostics table.

Cause

The user has tried to alter or drop a table that is serving as a violations table for another table.

Action

Do not alter or drop the violations table.

Cannot Open Dbospace *nnn*.

Cause

The database server is unable to access the specified dbospace. This message indicates a problem opening the tblspace or corruption in the initial chunk of the dbospace.

Action

Verify that the device or devices that make up the chunks of this dbospace are functioning properly and that you assigned them the correct operating-system permissions (rw-rw----). You might be required to perform a data restore.

Cannot Open Logical Log.

Cause

The database server is unable to access the logical-log files. Because the database server cannot operate without access to the logical log, you must resolve this problem.

Action

Verify that the chunk device where the logical-log files reside is functioning and has the correct operating-system permissions (rw-rw----).

Cannot Open Mirror Chunk *pathname*, errno = *nn*.

Cause

The database server cannot open the mirrored chunk of a mirrored pair. The chunk *pathname* and the operating-system error are returned.

Action

For more information about corrective actions, see your operating-system documentation.

Cannot Open Primary Chunk *pathname*, errno = *nnn*.

Cause

The primary chunk of a mirrored pair cannot be opened. The chunk *pathname* and the operating-system error are returned.

Action

For more information about corrective actions, see your operating-system documentation.

Cannot Open Primary Chunk *chunkname*.

Cause

The *initial* chunk of the dbspace cannot be opened.

Action

Verify that the chunk device is running properly and has the correct operating-system permissions (rw-rw----).

Cannot open sysams in database *name*, iserrno *number*.

Cause

An error occurred when the database server opened the **sysams** system table.

Action

Note the error *number* and contact Technical Support.

Cannot open sysdistrib in database *name*, iserrno *number*.

Cause

An error occurred when the database server accessed the `sysdistrib` system table.

Action

Note the error *number* and contact Technical Support.

Cannot open *system_table* in database *name*, iserrno *number*.

Cause

An error occurred when the database server opened the specified system table.

Action

Note the error *number* and contact Technical Support.

Cannot open sysstrigbody in database *name*, iserrno *number*.

Cause

An error occurred when the database server accessed the `sysstrigbody` system table.

Action

Note the error *number* and contact Technical Support.

Cannot open sysstriggers in database *name*, iserrno *number*.

Cause

An error occurred when the database server accessed the `sysstriggers` system table.

Action

Note the error *number* and contact Technical Support.

Cannot open sysxdtypes in database *name*, iserrno *number*.

Cause

An error occurred while accessing the `sysxdtypes` system table.

Action

Note the error *number* and contact Technical Support.

Cannot Perform Checkpoint, shut system down.

Cause

A thread that is attempting to restore a mirrored chunk has requested a checkpoint, but the checkpoint cannot be performed.

Action

Shut down the database server.

Cannot Restore to Checkpoint.

Cause

The database server is unable to recover the physical log and thus unable to perform fast recovery.

Action

If the database server does not come online, perform a data restore from dbspace backup.

Cannot Rollback Incomplete Transactions.

Cause

Within the fast-recovery or data-restore procedure, the logical-log records are first rolled forward. Then, open transactions that have not committed are rolled back. An open transaction could fail during the rollback, leaving some of the modifications from the open transaction in place. This error does not prevent the database server from moving to quiescent or online mode, but it might indicate an inconsistent database.

Action

To determine if any action is needed, use the onlog utility to examine the logical log.

Cannot update pagezero.

Cause

A failure occurred while the database server was trying to rewrite a reserved page during the reversion process.

Action

See previous messages in the log file for information, or contact Technical Support.

Cannot update syscasts in database *name*. Iserrno *number*.

Cause

An internal error occurred while inserting data into the `syscasts` system table.

Action

Contact Technical Support..

Can't affinity VP *mm* to phys proc *nn*.

Cause

The database server supports process affinity, but the system call to bind the virtual processor to a physical processor failed.

Action

See your operating-system documentation.

Changing the sbspace minimum extent value: old value *value1*, new value *value2*.

Cause

This informational message occurs when you issue the following command:
`onspaces -ch sbspace -Df "MIN_EXT_SIZE=value1" -y`

Action

None. For more information, see "onspaces -ch: Change sbspace default specifications" on page 20-17.

Checkpoint blocked by down space, waiting for override or shutdown.

Cause

A dbspace has gone down during a checkpoint interval. The database server is configured to wait for an override when this situation occurs.

Action

Either shut down the database server or issue an **onmode -O** command to override the down dbspace. For more information on the **onmode** utility, see Chapter 15, "The onmode utility," on page 15-1.

Checkpoint Completed: duration was *n* seconds.

Cause

A checkpoint completed successfully.

Action

None required.

Checkpoint Page Write Error.

Cause

The database server detected an error in an attempt to write checkpoint information to disk.

Action

For additional assistance in resolving this situation, contact Technical Support.

Checkpoint Record Not Found in Logical Log.

Cause

The logical log or the chunk that contains the logical log is corrupted. The database server cannot initialize.

Action

Perform a data restore from dbspace backup.

Chunk *chunkname* added to space *spacename*.

Cause

The variables in this message have the following values:

chunkname

is the name of the chunk that the database server administrator is adding.

spacename

is the name of the storage space to which the database server administrator is adding the chunk.

Action

None required.

Chunk *chunkname* dropped from space *spacename*.

Cause

The database server administrator dropped chunk *chunkname* from space *spacename*.

Action

None required.

Chunk *number nn pathname* -- Offline.

Cause

The indicated chunk in a mirrored pair has been marked with status D and taken offline. The other chunk in the mirrored pair is operating successfully.

Action

Take steps now to repair the chunk device and restore the chunk. The chunk *number* and chunk device *pathname* are displayed.

Chunk *number nn pathname* -- Online.

Cause

The indicated chunk in a mirrored pair has been recovered and is online (marked with status 0). The chunk *number* and chunk device *pathname* are displayed.

Action

None required.

The chunk *pathname* must have READ/WRITE permissions for owner and group.

Cause

The chunk *pathname* does not have the correct owner and group permissions.

Action

Make sure that you assigned the correct permissions (-rw-rw---) to the device on which the chunk is located.

The chunk *pathname* must have *owner-ID* and *group-ID* set to informix.

Cause

The chunk *chunkname* does not have the correct owner and group ID.

Action

Make sure the device on which the chunk is located has the ownership. On UNIX, both owner and group should be **informix**. On Windows, the owner must be a member of the **Informix-Admin** group.

The chunk *pathname* will not fit in the space specified.

Cause

The chunk *pathname* does not fit in the space that you specified.

Action

Choose a smaller size for the chunk, or free space where the chunk is to be created.

Cleaning stray LOs in sbspace *sbspacename*.

Cause

The database server administrator is running **onspaces -cl sbspacename**.

Action

None required.

Completed re-creating indexes.

Cause

The database server finished re-creating the deferred indexes.

Action

None required.

Configuration has been grown to handle up to *integer* chunks.

Cause

The database server administrator increased the number of chunks to the specified value by changing CONFIGSIZE or setting MAX_CHUNKS to a higher value.

Action

None required. The change was successful.

Configuration has been grown to handle up to *integer* dbslices.

Cause

The database server administrator increased the number of dbslices to the specified value by changing CONFIGSIZE or setting MAX_DBSLICES to a higher value.

Action

None required. The change was successful.

Configuration has been grown to handle up to *integer* dbspaces.

Cause

The database server administrator increased the number of dbspaces to the specified value by changing CONFIGSIZE or setting MAX_DBSPACES to a higher value.

Action

None required. The change was successful.

Continuing Long Transaction (for COMMIT): *tx 0xn*.

Cause

The logical log has filled beyond the long-transaction high-watermark (LTXHWM), but the offending long transaction is in the process of committing. In this case, the transaction is permitted to continue writing to the logical log and is not rolled back. The address of the transaction structure in shared memory is displayed as hexadecimal value *tx 0xn*.

Action

None required.

Could not disable priority aging: *errno = number*.

Cause

An operating-system call failed while it was trying to disable priority aging for the CPU virtual processor. The system error *number* associated with the failure is returned.

Action

See your operating-system documentation.

Could not fork a virtual processor: errno = *number*.

Cause

The fork of a virtual processor failed. The database server returns the operating-system error *number* associated with the failure.

Action

For information on determining the maximum number of processes available per user and for the system as a whole, refer to your operating-system documentation.

Create_vp: cannot allocate memory.

Cause

The database server cannot allocate new shared memory.

Action

The database server administrator must make more shared memory available. This situation might require increasing SHMTOTAL or reconfiguring the operating system. This message is usually accompanied by other messages that give additional information.

Messages: D-E-F

Dataskip is OFF for all dbspaces.

Cause

Informational.

Action

None required.

Dataskip is ON for all dbspaces.

Cause

Informational.

Action

None required.

Dataskip is ON for dbspaces: *dbspacelist*.

Cause

Informational; DATASKIP is ON for the specified dbspaces.

Action

None required.

Dataskip will be turned {ON|OFF} for *dbspacename*.**Cause**

Informational; DATASKIP is ON or OFF for the specified dbspace.

Action

None required.

DBSERVERALIASES exceeded the maximum limit of 32**Cause**

The limit of 32 aliases was reached.

Action

Nothing. Only the first 32 will be used.

DBSPACETEMP internal list not initialized, using default.**Cause**

An error occurred while initializing a user-specified DBSPACETEMP list. Typically this condition is due to a memory-allocation failure.

Action

Check for accompanying error messages.

The DBspace/BLOBspace *spacename* is now mirrored.**Cause**

You successfully added mirroring to the indicated storage space.

Action

None required.

The DBspace/BLOBspace *spacename* is no longer mirrored.**Cause**

You have ended mirroring for the indicated storage space.

Action

None required.

Dbospace *dbspacename* for Physical-log File not found.

Cause

The dbospace *dbspacename* specified by the PHYSDBS configuration parameter does not exist. As a consequence, the database server cannot complete initialization.

Action

Use a dbospace known to exist.

***devname*: write failed, file system is full.**

Cause

Because the file system *devname* is full, the write failed.

Action

Free some space in *devname*.

Dropping temporary tblspace *0xn*, recovering *nn* pages.

Cause

During shared-memory initialization, the database server routinely searches for temporary tables that are left without proper cleanup. If the database server finds a temporary table, it drops the table and recovers the space. The database server located the specified temporary tblspace and dropped it. The value *0xn* is the hexadecimal representation of the tblspace number.

Action

None required.

Dynamically allocated new shared memory segment (size *nnnn*).

Cause

This status message informs you that the database server successfully allocated a new shared-memory segment of size *nnnn*.

Action

None required.

ERROR: NO "wait for" locks in Critical Section.

Cause

The database server does not permit a thread to own locks that might have to wait while that thread is within a critical section. Any such lock request is denied, and an ISAM error message is returned to the user.

Action

The error reported is an internal error. Contact IBM Informix Technical Support.

Error building sysmaster database. See *outfile*.

Cause

Errors were encountered in building the sysmaster database. The file *outfile* contains the result of running the script *buildsmi*.

Action

See the file *outfile*.

Error in dropping system defined type.

Cause

An internal error occurred while updating either the **sysxdtypes**, **sysctddesc**, or **sysxdtpeauth** system table.

Action

Contact Technical Support.

Error in renaming systdist.

Cause

An internal error occurred while trying to find and rename the **Informix.systdist** SPL routine.

Action

Contact Technical Support.

Error removing sysdistrib row for *tabid* = *tabid*, *colid* = *colid* in database *name*. *iserrno* = *number*

Cause

An error occurred while updating the **sysdistrib** system table.

Action

Note the error *number* and contact Technical Support.

Error writing *pathname* *errno* = *number*.

Cause

The operating system cannot write to *pathname*. *Number* is the number of the operating-system error that was returned.

Action

Investigate the cause of the operating-system error. Usually it means that no space is available for the file. It might also mean that the directory does not exist or that no write permissions exist.

Error writing shmemp to file *filename* (error). Unable to create output file *filename* errno=*mm*. Error writing *filename* errno=*nn*.

Cause

The database server detected an error in an attempt to write shared memory to *filename*. The first message is followed by one of the next two. Either the attempt failed because the output file could not be created or because the contents of shared memory could not be written. The error refers to the operating-system error that prompted the attempted write of shared memory to a file. The value of *nn* is the operating-system error.

Action

See your operating-system documentation.

Fail to extend physical log space.

Cause

The attempt to extend the physical log space failed. Either the path does not exist or the permissions are incorrect.

Action

Use a path that exists. Check permissions on the current working directory. You or the system administrator must give your group execute permission on the current working directory. After your group has been given permission, retry the operation that generated this message.

Fatal error initializing CWD string. Check permissions on current working directory. Group *groupname* must have at least execute permission on '.'.

Cause

Group *groupname* does not have execute permission for the current working directory.

Action

Check permissions on the current working directory. You or the system administrator must give your group execute permission on the current working directory. After your group has been given permission, retry the operation that generated this message.

The following tables have outstanding old version data pages due to an In-Place Alter Table. Perform UPDATE *tablename* SET *column* = *column* WHERE 1=1; to clear these pages from the following tables.

Cause

Reversion to a previous version of the database server has been attempted while an in-place ALTER TABLE is in progress. The previous versions of the database server cannot handle tables that have multiple schemas of rows in them.

Action

Force any in-place alters to complete by updating the rows in the affected tables before you attempt to revert to a previous version of the database server. To do this, create a dummy update in which a column in the table is set to its own value, forcing the row to be updated to the latest schema in the process without actually changing column values. Rows are always altered to the latest schema, so a single pass through the table that updates all rows completes all outstanding in-place alters.

Fragments *dbspacename1 dbspacename2* of table *tablename* set to non-resident.

Cause

The specified fragments of *tablename* either have been set to nonresident by the SET TABLE statement.

Action

None required.

Forced-resident shared memory not available.

Cause

The database server port for your computer does not support forced-resident shared memory.

Action

None required.

Freed *mm* shared-memory segment(s) *number* bytes.

Cause

The database server sends this message to the message log after you run the **-F** option of the **onmode** utility to free unused memory. The message informs you of the number of segments and bytes that the database server successfully freed.

Action

None required.

Messages: G-H-I

gcore *pid*; mv *core.pid* *dir/core.pid*.ABORT.

Cause

This status message during a database server failure provides the name and place of each core file associated with the virtual processors.

Action

None required.

I/O *function* chunk *mm*, pagenum *nn*, pagecnt *aa* --> errno = *bb*.

Cause

An operating-system error occurred during an attempt to access data from disk space. The operating-system function that failed is defined by *function*. The chunk number and physical address of the page where the error occurred are displayed as integers. The *pagecnt* value refers to the number of pages that the thread was attempting to read or write. If an *errno* value is displayed, it is the number of the operating-system error and might explain the failure. If *function* is specified as *bad request*, some unexpected event caused the I/O attempt on an invalid chunk or page.

Action

If the chunk status changes to D, or down, restore the chunk from its mirror or repair the chunk. Otherwise, perform a data restore.

I/O error, *primary/mirror* Chunk *pathname* -- Offline (*sanity*).

Cause

The database server detected an I/O error on a primary or mirror chunk with *pathname*. The chunk was taken offline.

Action

Check that the device on which the chunk was stored is functioning as intended.

Deleted Indexes idx1 and idx 2 error message

Informix *database_server* Initialized - Complete Disk Initialized.

Cause

Disk space and shared memory have been initialized. Any databases that existed on the disk before the initialization are now inaccessible.

Action

None required.

Informix *database_server* Initialized - Shared Memory Initialized.

Cause

Shared memory has been initialized.

Action

None required.

Informix *database_server* Stopped.

Cause

The database server has moved from quiescent mode to offline mode. The database server is offline.

Action

None required.

ERROR: Insufficient available disk in the root dbspace to increase the entire Configuration save area.

Cause

The user attempted to increase the number of storage objects to a specific value by changing CONFIGSIZE or setting MAX_DBSPACES, MAX_DBSLICES, or MAX_CHUNKS to a higher value, but the database server did not have enough rootspace for the increased number of storage objects. A storage object might be a dbspace, dbslice, or chunk.

Action

Increase the size of the root dbspace or reset CONFIGSIZE, MAX_DBSPACES, MAX_DBSLICES, or MAX_CHUNKS to a lower value and restart the database server. For example, if you set MAX_CHUNKS to 32,768, but the root dbspace did not have enough space, set MAX_CHUNKS to a lower value.

Insufficient available disk in the root dbspace for the CM save area. Increase the size of the root dbspace in the ONCONFIG file and reinitialize the server.

Cause

The cause might be one of the following:

- The user attempted to increase the number of storage objects to a specific value by changing CONFIGSIZE or setting MAX_DBSPACES, MAX_DBSLICES, or MAX_CHUNKS to a higher value, but the database server did not have enough rootspace for the increased number of storage objects. A storage object might be a dbspace, dbslice, or chunk.
- The user converted to a database server version that requires slightly more rootspace, but it is not available (this case is unlikely).

Action

Take one of the following actions:

- Increase the size of the root dbspace or reset CONFIGSIZE, MAX_DBSPACES, MAX_DBSLICES, or MAX_CHUNKS to a lower value and restart the database server. For example, if you set MAX_DBSPACES to 32,768 but the root dbspace did not have enough space, set MAX_DBSPACES to a lower value.
- Increase the size of the root dbspace and reinitialize the database server.

Internal overflow of shmid's, increase system max shared memory segment size.

Cause

The database server was initializing shared memory when it ran out of internal storage for the shared-memory IDs associated with this segment.

Action

Increase the value of your maximum kernel shared-memory segment size, usually SHMMAX. For more information, see your operating-system documentation.

Messages: J-K-L-M

Listener-thread err = *error_number*: *error_message*.

Cause

A listener thread has encountered an error. This message displays the error number and message text.

Action

For the cause and corrective action, see the IBM Informix Information Center at <http://publib.boulder.ibm.com/infocenter/idshelp/v117/index.jsp>.

Lock table overflow - user id *mm* session id *nn*.

Cause

A thread attempted to acquire a lock when no locks were available. The user ID and session ID are displayed.

Action

Increase the LOCKS configuration parameter, and initialize shared memory.

Logical-log File not found.

Cause

The checkpoint record in the root dbspace reserved page is corrupted.

Action

Perform a data restore from dbspace backup.

Logical Log *nn* Complete.

Cause

The logical-log file identified by log-ID number *nn* is full. The database server automatically switches to the next logical-log file in the sequence.

Action

None required.

Logical logging *vberror* for *type:subtype* in (*failed_system*).

Cause

Logging failed. The log record that caused the error is identified as follows:

type Is the logical-log record type.

subtype
Is the logging subsystem.

failed_system
Is the name of an internal function that indicates what system failed to log.

Action

Contact Technical Support.

Log Record: **log = ll, pos = 0xn, type = type:subtype(snum), trans = xx**

Cause

The database server detected an error during the rollforward portion of fast recovery or logical-log restore.

The log record that caused the error is identified as follows:

ll Is the logical-log ID where the record is stored.

0xn Is the hexadecimal address position within the log.

type Is the logical-log record type.

subtype
Is the logging subsystem.

snum Is the subsystem number.

xx Is the transaction number that appears in the logical log.

Action

Contact Technical Support.

Log record (*type:subtype*) at log *nn, 0xn* was not undone.

Cause

A log undo failed because a log is corrupt.

The log record that caused the error is identified as follows:

type Is the logical-log record type.

subtype
Is the logging subsystem.

nn Is the logical-log ID where the record is stored.

0xn Is the hexadecimal address position within the log.

Action

To determine if any action is needed, use the onlog utility to examine the logical log. Contact Technical Support.

Log record (*type:subtype*) failed, partnum *pnum* row *rid* iserrno *num*.

Cause

A logging failure occurred.

The log record that caused the error is identified as follows:

type Is the logical-log record type.

subtype
Is the logging subsystem.

pnum Is the part number.

rid Is the row ID.

num Is the iserror number.

Action

Contact Technical Support.

Log record (*type:subtype*) in log *nn*, offset *0xn* was not rolled back.

Cause

A log undo failed because a log is corrupt.

The log record that caused the error is identified as follows:

type Is the logical-log record type.

subtype
Is the logging subsystem.

log Is the logical-log ID where the record is stored.

offset Is the hexadecimal address position within the log.

Action

To determine if any action is needed, use the onlog utility to examine the logical log. Contact Technical Support.

Logical Recovery allocating *nn* worker threads *thread_type*.

Cause

The database server determined the number of worker threads that will be used for parallel recovery. The variable *thread_type* can assume the values ON_RECVRY_THREADS or OFF_RECVRY_THREADS.

Action

This status message requires no action. If you want a different number of worker threads allocated for parallel recovery, change the value of the ONCONFIG configuration parameter ON_RECVRY_THREADS or OFF_RECVRY_THREADS.

Logical Recovery Started.

Cause

Logical recovery began.

Action

This status message requires no action.

Maximum server connections *number*.

Cause

Outputs with each checkpoint message to indicate the maximum number of concurrent connections to the database server since the last restart.

Action

This message helps the customer track license usage to determine when more licenses need to be purchased. For assistance, Contact Technical Support.

Memory allocation error.

Cause

The database server ran out of shared memory.

Action

Take one of the following actions:

1. Increase swap space on the computer.
2. Check kernel shared-memory parameters for limits on shared memory.
3. Decrease the size of the memory allocated, with the **buffers** field in the BUFFERPOOL configuration parameter.
4. Increase the virtual-memory size (SHMVIRTSIZE), the size of the added segments, (SHMADD), or your total shared-memory size (SHMTOTAL).

Mirror Chunk *chunkname* added to space *spacename*. Perform manual recovery.

Cause

Fast recovery, full recovery, or an HDR secondary has recovered the add of a mirror chunk. It does not perform automatic mirror recovery, however. The administrator must do this.

Action

Use either the **onspaces** utility or ON-Monitor to attempt to recover the mirror chunks.

Mixed transaction result. (*pid=nn user=userid*).

Cause

You receive this message only when more than one database server is involved in a transaction. This message indicates that a database server, after preparing a transaction for commit, heuristically rolled back the transaction, and the global transaction completed inconsistently. The *pid* value is the user-process identification number of the coordinator process. The value of *user* is the user ID associated with the coordinator process.

Action

See the information on recovering manually from failed two-phase commit in your *IBM Informix Administrator's Guide*.

mt_shm_free_pool: pool *Oxn* has blocks still used (id *nn*).

Cause

An internal error occurred during a pool deallocation because blocks are still associated with the pool.

Action

Contact Technical Support.

mt_shm_init: can't create *resident/virtual* segment.

Cause

The causes for the failure to create the resident or virtual segment are as follows: (1) the segment size is less than the minimum segment size; (2) the segment size is larger than the maximum segment size; (3) allocating another segment would exceed the allowable total shared-memory size; or (4) a failure occurred while the database server was trying to allocate the segment.

Action

If you suspect that this error was generated because of item 1 or 2 in the preceding paragraph, Contact Technical Support. To correct item 3, increase the SHMTOTAL value in your ONCONFIG configuration file. For additional information about errors generated because of item 4, see your logical-log file.

mt_shm_remove: WARNING: may not have removed all/correct segments.

Cause

When the operating system tried to remove the shared-memory segments associated with the database server, the last segment did not equal the last segment registered internally. This situation is probably due to the unexpected failure of the database server.

Action

Remove any segments that were not cleaned up.

Messages: N-O-P

Newly specified value of *value* for the pagesize in the configuration file does not match older value of *value*. Using the older value.

Cause

This message displays upon database server restart. The PAGESIZE value changed in the ONCONFIG file after the database server was initialized.

Action

The database server uses the older PAGESIZE value.

Not enough main memory.

Cause

The database server detected an error in an attempt to acquire more memory space from the operating system.

Action

For more information about shared-memory configuration and management, refer to your operating-system documentation.

Not enough logical-log files, Increase LOGFILES.

Cause

During a data restore, the value of the LOGFILES configuration must always be greater than or equal to the total number of logical-log files. At some point during the restore, the number of logical-log files exceeded the value of LOGFILES.

Action

Increase the value of LOGFILES in ONCONFIG.

Not enough physical procs for affinity.

Cause

The ONCONFIG parameters AFF_NPROCS and AFF_SPROC are not correctly set. AFF_SPROC plus AFF_NPROCS is greater than the number of physical processors on your computer or node.

Action

Reset AFF_NPROCS and AFF_SPROC, such that the value AFF_SPROC plus value of AFF_NPROCS is less than or equal to the number of physical processors.

The number of configured CPU poll threads exceeds NUMCPUVPS.

Cause

The number of in-line poll threads that you specified in the ONCONFIG configuration file exceeds the number of CPU virtual processors.

Action

Reduce the number of in-line poll threads to be less than or equal to the number of CPU virtual processors.

onconfig parameter *parameter* modified from *old_value* to *new_value*.

Cause

When the database server shared memory is reinitialized, this message documents any changes that occurred since the last initialization.

Action

None required.

oninit: Cannot have SINGLE_CPU_VP non-zero and number of CPU VPs greater than 1.

Cause

The ONCONFIG file contains VPCLASS cpu with a num= value greater than 1 and a nonzero value for SINGLE_CPU_VP. SINGLE_CPU_VP must be 0 (or omitted) when there are more than 1 CPU VPs.

Action

Correct the ONCONFIG file and restart the database server.

oninit: Cannot have SINGLE_CPU_VP non-zero and user-defined VP classes.

Cause

The ONCONFIG file contains a user-defined VPCLASS as well as a nonzero value for SINGLE_CPU_VP. SINGLE_CPU_VP must be 0 (or omitted) when the ONCONFIG file contains a user-defined VPCLASS.

Action

Correct the ONCONFIG file and restart the database server.

oninit: Cannot mix VPCLASS cpu and NUMCPUVPS, AFF_SPROC, AFF_NPROCS, or NOAGE parameters.

Cause

The ONCONFIG file contains both VPCLASS cpu and one or more of the other listed parameters. It cannot contain both.

Action

Correct the ONCONFIG file and restart the database server.

oninit: Cannot mix VPCLASS aio and NUMAIOVPS parameters.

Cause

The ONCONFIG file contains both VPCLASS aio and NUMAIOVPS. It cannot contain both.

Action

Correct the ONCONFIG file and restart the database server.

oninit: Fatal error in initializing ASF with 'ASF_INIT_DATA' flags asfcode = '25507'.

Cause

The **nettype** value specified in the **sqlhosts** file or registry for the database server is invalid or unsupported, or the **servicename** specified in the **sqlhosts** file or registry for the database server is invalid.

Action

Check the **nettype** and **servicename** values in the **sqlhosts** file or registry for each DBSERVERNAME and for the DBSERVERALIASES. Check the **nettype** value in each NETTYPE parameter in the ONCONFIG file.

oninit: invalid or missing name for Subsystem Staging Blobspace.

Cause

You set the configuration parameter STAGEBLOB to a blobspace that does not exist.

Action

Use the **-d** option of **onspaces** to create the blobspace specified in STAGEBLOB, and restart the database server.

Cannot alter a table which has associated violations table.

Cause

The user tried to add, drop, or modify a column in a table that has a violations table associated with it.

Action

Do not change the columns in the user table.

oninit: Too many VPCLASS parameters specified.

Cause

Too many VPCLASS parameter lines have been specified in the ONCONFIG file.

Action

Reduce the number of VPCLASS lines, if possible. If not possible, contact Technical Support.

oninit: VPCLASS *classname* bad affinity specification.

Cause

The affinity specification for the VPCLASS line is incorrect. Affinity is specified as a range:

For m , use processor m .

For m to n , use processors in the range m to n inclusive, where $m \leq n$, $m \geq 0$, and $n \geq 0$.

Action

Correct the VPCLASS parameter in the ONCONFIG file and restart the database server.

oninit: VPCLASS *classname* duplicate class *name*.

Cause

The VPCLASS *classname* in the ONCONFIG file has a duplicate name. VP class names must be unique.

Action

Correct the duplicate name and restart the database server.

oninit: VPCLASS *classname* illegal option.

Cause

One of the fields in the VPCLASS *classname* parameter is illegal.

Action

Correct the parameter in the ONCONFIG file and restart the database server.

oninit: VPCLASS *classname* maximum number of VPs is out of the range 0-10000.

Cause

The maximum number of VPs specified by a VPCLASS parameter line must be in the range 1 to 10,000.

Action

Correct the value and restart the database server.

oninit: VPCLASS *classname* name is too long. Maximum length is *maxlength*.

Cause

The length of the name field in VPCLASS *classname* is too long.

Action

Choose a shorter class name, correct the ONCONFIG file, and restart the database server.

oninit: VPCLASS *classname* number of VPs is greater than the maximum specified.

Cause

The initial number of VPs specified by a VPCLASS parameter is greater than the maximum specified by the same VPCLASS parameter.

Action

Correct the VPCLASS parameter and restart the database server.

oninit: VPCLASS *classname* number of VPs is out of the range 0-10000.

Cause

The initial number of VPs specified by a VPCLASS parameter line must be in the range 1 to 10,000.

Action

Correct the value and restart the database server.

onmode: VPCLASS *classname* name is too long. Maximum length is *maxlength*.

Cause

The name of a dynamically added VP class that **onmode -p** specifies is too long.

Action

Choose a shorter name, and retry the **onmode -p** command.

Optical Subsystem is running.

Cause

You set the value of the STAGEBLOB parameter in the configuration file, and the database server is communicating properly with the optical-storage subsystem.

Action

No action is required.

Optical Subsystem is not running.

Cause

You set the value of the STAGEBLOB parameter in the configuration file, but the database server cannot detect the existence of the optical-storage subsystem.

Action

Check that the optical subsystem is online.

Optical Subsystem STARTUP Error.

Cause

The database server detects that the optical-storage subsystem is running, but the database server cannot communicate with it properly.

Action

Check your optical subsystem for errors.

Online Mode.

Cause

The database server is in online mode. Users can access all databases

Action

This status message requires no action.

onspaces: unable to reset dataskip.

Cause

This error message comes from the **onspaces** utility. For some reason, the utility cannot change the specification of DATASKIP (ON or OFF) across all dbspaces in the database server instance.

Action

You are unlikely to receive this message. If the error persists after you restart the database server, Contact Technical Support.

Open transaction detected when changing log versions.

Cause

The database server detected an open transaction while it was trying to convert the data from a previous version of the database server.

Action

Conversion is not allowed unless the last record in the log is a checkpoint. You must restore the previous version of the database server, force a checkpoint, and then retry conversion.

Out of message shared memory.

Cause

The database server could not allocate more memory for the specified segment.

Action

For additional information, see the log file.

Out of resident shared memory.

Cause

The database server could not allocate more memory for the specified segment.

Action

For additional information, see the log file.

Out of virtual shared memory.

Cause

The database server could not allocate more memory for the specified segment.

Action

For additional information, see the log file.

PANIC: Attempting to bring system down.

Cause

A fatal database server error occurred.

Action

See the error that caused the panic and attempt the corrective action suggested by the error message. For additional information that might explain the failure, refer also to other messages in the message-log file.

Participant site *database_server* heuristically rolled back.

Cause

A remote site rolled back a transaction after it reached the prepared-for-commit phase.

Action

You might need to roll back the transaction on other sites and then restart it.

Physical recovery complete: *number pages examined*, *number pages restored*.

Cause

This message displays during fast recovery. The *number of pages examined* indicates the number of page images that exist in the physical log. The *number of pages restored* indicates the actual number of pages that are restored from the physical log. The number of pages restored is always less than or equal to the number examined.

The database server might physically log a page image multiple times between checkpoints. Physical recovery restores only the first logged page image.

If a page stays in the memory buffer pool, the database server physically logs it once per checkpoint, and stores one page image in the physical log. If the buffer pool is too small, a page that is being updated many times might get forced out of the buffer pool to disk and then brought back into memory for the next update. Each time the page is brought into memory, it is physically logged again, resulting in duplicate page images in the physical log.

Action

If the *number of pages examined* is much larger than the *number of pages restored*, increase the size of the buffer pool to reduce the number of duplicate before-images. For more information, see the *IBM Informix Performance Guide*.

Physical recovery started at page (*chunk:offset*).

Cause

This message displays during fast recovery. *Chunk* is the number of the chunk that contains the physical log. *Offset* is the page offset of the start of the physical log entries. Physical recovery begins restoring pages from that point.

Action

No action required. For information on fast recovery, see the *IBM Informix Administrator's Guide*.

Portions of partition partnum of table tablename in database dbname were not logged. This partition cannot be rolled forward.

Cause

Light appends occurred to the operational table since the last backup.

Action

If you want full access to data in this table, you need to alter the table to raw and then to the desired table type. This alter operation removes inconsistencies in the table that resulted from replaying non-logged operations such as light appends.

Possible mixed transaction result.

Cause

This message indicates that error -716 has been returned. Associated with this message is a list of the database servers where the result of a transaction is unknown.

Action

For information on determining if a transaction was implemented inconsistently, see the *IBM Informix Administrator's Guide*.

Prepared participant site *server_name* did not respond.

Cause

Too many attempts were made to contact remote site *server_name*. After several timeout intervals were met, the site was determined to be down.

Action

Verify that the remote site is online and that it is correctly configured for distributed transactions. Once the remote site is ready, reinitiate the transaction.

Prepared participant site *server_name* not responding.

Cause

The database server is attempting to contact remote site *server_name*. For some unknown reason, the database server cannot contact the remote site.

Action

Verify that the remote site is online and that it is correctly configured for distributed transactions.

Messages: Q-R-S

Quiescent Mode.

Cause

The database server has entered quiescent mode from some other state. On UNIX, only users logged in as **informix** or as **root** can interact with the database server. On Windows, only members of the **Informix-Admin** group can interact with the database server. No user can access a database.

Action

None required.

Read failed. Table *name*, Database *name*, **iserrno = number**

Cause

An error occurred reading the specified system table.

Action

Note the error number and contact Technical Support.

Recovery Mode.

Cause

The database server entered the recovery mode. No user can access a database until recovery is complete.

Action

None required.

Recreating index: '*dbname*:"*owner*".*tablename-idxname*'.

Cause

After DDL statements implicitly or explicitly create one or more new indexes, but the database server terminates abnormally before the next checkpoint, re-creation of the new indexes is deferred until after logical recovery, instead of adding each index item row by row. After logical recovery ends, the server begins a parallel index build to re-create them. This message indicates when re-creation commences for each deferred index. (But if an index was dropped before the abnormal shutdown, it will not be re-created after logical recovery, and no message referencing that index will be printed.)

Action

None required.

Rollforward of log record failed, iserrno = *nn*.

Cause

The message appears if, during fast recovery or a data restore, the database server cannot roll forward a specific logical-log record. The database server might be able to change to quiescent or online mode, but some inconsistency could result. For further information, see the message that immediately precedes this one. The *iserrno* value is the error number.

Action

Contact IBM Informix Technical Support.

Root chunk is full and no additional pages could be allocated to chunk descriptor page.

Cause

The root chunk is full.

Action

To free space in the root chunk, take one of the following actions:

- Drop and re-create the **sysmaster** database.
- Move user tables from the root dbspace to another dbspace.
- Refragment tables.

scan_logundo: subsys *ss*, type *tt*, iserrno *ee*.

Cause

A log undo failed because log type *tt* is corrupt.

The variables in this message have the following values:

- ss** Is the subsystem name.
tt Is the logical-log record type.
ee Is the iserror number.

Action

Examine the logical log with the onlog utility to determine if any action is needed. Contact Technical Support.

Session completed abnormally. Committing *tx id 0xm*, flags *0xn*.

Cause

Abnormal session completion occurs only when the database server is attempting to commit a transaction that has no current owner, and the transaction develops into a long transaction. The database server forked a thread to complete the commit.

Action

None required.

Session completed abnormally. Rolling back *tx id 0xm*, flags *0xn*.

Cause

Abnormal session completion occurs only when the database server is attempting to commit a distributed transaction that has no current owner, and the transaction develops into a long transaction. The database server forked a thread that rolled back the transaction.

Action

None required.

semctl: *errno* = *nn*.

Cause

When the database server initialized a semaphore, an error occurred. The operating-system error is returned.

Action

See your operating-system documentation.

semget: *errno* = *nn*.

Cause

An allocation of a semaphore set failed. The operating-system error is returned.

Action

See your operating-system documentation.

shmat: *some_string os_errno: os_err_text*.

Cause

An attempt to attach to a shared-memory segment failed. The system error number and the suggested corrective action are returned.

Action

Review the corrective action (if given), and determine if it is reasonable to try. For more information, refer to your operating-system documentation.

shmctl: *errno* = *nn*.

Cause

An error occurred while the database server tried to remove or lock a shared-memory segment. The operating-system error number is returned.

Action

See your operating-system documentation.

shmdt: errno = *nn*.

Cause

An error occurred while the database server was trying to detach from a shared-memory segment. The operating-system error number is returned.

Action

See your operating-system documentation.

shmem sent to *filename*.

Cause

The database server wrote a copy of shared memory to the specified file as a consequence of an assertion failure.

Action

None.

shmget: *some_str* *os_errno*: *key* *shmkey*: *some_string*.

Cause

Either the creation of a shared-memory segment failed, or an attempt to get the shared-memory ID associated with a certain key failed. The system error number and the suggested corrective action are returned.

Action

Consult your operating-system documentation.

Shutdown (onmode -k) or override (onmode -O).

Cause

A dbspace has gone down during a checkpoint interval. The database server is configured to wait for an override when this situation occurs.

When the checkpoint actually happens, the following message appears: Checkpoint blocked by down space, waiting for override or shutdown.

Action

Either shut down the database server or issue an **onmode -O** command to override the down dbspace. For more information on the **onmode** utility, see Chapter 15, "The onmode utility," on page 15-1.

Shutdown Mode.

Cause

The database server is in the process of moving from online mode to quiescent mode.

Action

None required.

Space *spacename* added.

Cause

The database server administrator added a new storage space *spacename* to the database server.

Action

None required.

Space *spacename* dropped.

Cause

The database server administrator dropped a storage space *spacename* from the database server.

Action

None required.

Space *spacename* -- Recovery Begins(*addr*).

Cause

This informational message indicates that the database server is attempting to recover the storage space.

The variables in this message have the following values:

spacename

Is the name of the storage space that the database server is recovering.

addr Is the address of the control block.

Action

None required.

Space *spacename* -- Recovery Complete(*addr*).

Cause

This informational message indicates that the database server recovered the storage space.

The variables in this message have the following values:

spacename

Is the name of the storage space that the database server has recovered.

addr Is the address of the control block.

Action

None required.

Space *spacename* -- Recovery Failed(*addr*).

Cause

This informational message indicates that the database server was unable to recover the storage space.

The variables in this message have the following values:

spacename

Is the name of the storage space that the database server failed to recover.

addr Is the address of the control block.

Action

None required.

sysmaster database built successfully.

Cause

The database server successfully built the sysmaster database.

Action

None required.

Successfully extend physical log space

Cause

The physical log space was successfully extended to the file `plog_extend.servernum` under the designated path.

Action

None required.

Messages: T-U-V

This ddl operation is not allowed due to deferred constraints pending on this table and dependent tables.

Cause

This error is returned when you attempt to start a violations table and constraints are in deferred mode.

Note: No error is returned if you start a violations table and then later set the constraints to deferred. However, the violations get undone immediately rather than written into the deferred constraint buffer. For more information, see the *IBM Informix Guide to SQL: Syntax*.

Action

If you would like to start a violations table, you must either change the constraint mode to immediate or commit the transaction.

This type of space does not accept log files.

Cause

Adding a logical-log file to a blobspace or sbspace is not allowed.

Action

Add the logical-log file to a dbspace. For more information, see “onparams -a -d *dbspace*: Add a logical-log file” on page 17-2.

TIMER VP: Could not redirect I/O in initialization, errno = nn.

Cause

The operating system could not open the null device or duplicate the file descriptor associated with the opening of that device. The system error number is returned.

Action

See your operating-system documentation.

Too Many Active Transactions.

Cause

During a data restore, there were too many active transactions. At some point during the restore, the number of active transactions exceeded 32 kilobytes.

Action

None.

Too many violations.

Cause

The number of violations in the diagnostics table exceeds the limit that is specified in the MAX VIOLATIONS clause of the START VIOLATIONS TABLE statement. When a single statement on the target table (such as an INSERT or UPDATE statement) inserts more records into the violations table than the limit that is specified by the MAX VIOLATIONS clause, this error is returned to the user who issued the statement on the target table.

Action

To resolve this error, perform one of the following actions:

- Omit the MAX VIOLATIONS clause in the START VIOLATIONS TABLE statement when you start a violations table. Here, you are specifying no limit to the number of rows in the violations table.
- Set MAX VIOLATIONS to a high value.

Transaction Not Found.

Cause

The logical log is corrupt. This situation can occur when a new transaction is started, but the first logical-log record for the transaction is not a BEGWORK record.

Action

Contact Technical Support.

Transaction heuristically rolled back.

Cause

A heuristic decision occurred to roll back a transaction after it completed the first phase of a two-phase commit.

Action

None required.

Transaction table overflow - user id *nn*, process id *nn*.

Cause

A thread attempted to allocate an entry in the transaction table when no entries in the shared-memory table were available. The user ID and process ID of the requesting thread are displayed.

Action

Try again later.

Unable to create output file *filename* errno = *nn*.

Cause

The operating system cannot create output file *filename*. The *errno* is the number of the operating-system error returned.

Action

Verify that the directory exists and has write permissions.

Unable to extend *nn* reserved pages for *purpose* in root chunk.

Cause

The operating system cannot extend to *nn* reserved pages for *purpose* in root chunk. (The value *purpose* can be either Checkpoint/Log, DBSpace, Chunk, or Mirror Chunk.)

Action

Reduce the ONCONFIG parameter for the resource cited; bring the database server up and free some space in the primary root chunk. Then reattempt the same operation.

Unable to initiate communications with the Optical Subsystem.

Cause

The optical driver supplied by the optical-drive vendor has indicated that the drive is not accessible.

Action

Check driver installation and cabling between the computer and the drive.

Unable to start SQL engine.

Cause

The database server encountered an out-of-memory condition.

Action

No action is necessary.

Unable to open tblspace *nn*, iserrno = *nn*.

Cause

The database server cannot open the specified tblspace. (The value *nn* is the hexadecimal representation of the tblspace number.)

Action

See the ISAM error message number *nn*, which should explain why the tblspace cannot be accessed. The error message appears in *IBM Informix Error Messages*.

The value of pagesize *pagesize* specified in the config file is not a valid pagesize. Use 2048, 4096 or 8192 as the value for PAGESIZE in the onconfig file and restart the server.

Cause

This message displays upon disk initialization. The value of PAGESIZE that was specified in the ONCONFIG file is not a valid value.

Action

Restart the database server with a valid PAGESIZE value.

Violations table is not started for the target table.

Cause

If you issue a STOP VIOLATIONS TABLE statement for which no violations table is started, you receive this message.

Action

To recover from this error, you must start a violations table for the target table.

Violations table reversion test completed successfully.

Cause

This message is recorded in the **logmessage** table in the **sysmaster** database when the **revtestviolations.sh** script has completed successfully (no open violations tables were found).

Action

No action is necessary. For more information on **revtestviolations.sh**, see the *IBM Informix Migration Guide*.

Violations table reversion test failed.

Cause

When the database server finds an open violations table, it reports errors 16992 and 16993 in the **logmessage** table in the **sysmaster** database and aborts the reversion process.

Action

When this message appears, you must issue the STOP VIOLATIONS TABLE FOR *table_name* command for each open violations table. After you close all open violations tables, you can restart the reversion process.

Violations table reversion test start.

Cause

This message is recorded in the **logmessage** table in the **sysmaster** database when the **revtestviolations.sh** script is executed.

Action

No action is necessary. For more information on **revtestviolations.sh**, see the *IBM Informix Migration Guide*.

Violations tables still exist.

Cause

This message is recorded in the **logmessage** table in the **sysmaster** database when an open violations table is found.

Action

When this message appears, you must issue the STOP VIOLATIONS TABLE FOR *table_name* command for each open violations table. After you close all open violations tables, you can restart the reversion process.

Virtual processor limit exceeded.

Cause

You configured the database server with more than the maximum number of virtual processors allowed (1000).

Action

To reduce the number of virtual processors, decrease the values of VPCLASS, NUMCPUVPS, NUMAIOVPS, or NETTYPE in your ONCONFIG file.

VPCLASS *classname* name is too long. Maximum length is *maxlength*.

Cause

This message indicates an internal error.

Action

Contact Technical Support.

VPCLASS *classname* duplicate class name.

Cause

This message indicates an internal error.

Action

Contact Technical Support.

VPCLASS *classname* Not enough physical procs for affinity.

Cause

The physical processors in the affinity specification for the VP class *classname* do not exist or are offline. The problem might be with the VPCLASS parameter for cpu class VPs or with the AFF_SPROC and AFF_NPROCS parameters.

Action

Make sure the named processors are online. Correct the affinity specification for the named VP class. Restart the database server.

Messages: W-X-Y-Z

WARNING: aio_wait: errno = *nn*.

Cause

While the database server was waiting for an I/O request to complete, it generated error number *nn* on an operation that it was attempting to execute.

Action

Contact Technical Support for assistance.

WARNING: Buffer pool size may cause database server to get into a locked state. Recommended minimum buffer pool size is *num* times maximum concurrent user threads.

Cause

There are not enough buffers in the buffer pool. The database server could use all available buffers and cause a deadlock to occur.

Action

Change the **buffers** field in the BUFFERPOOL parameter in the ONCONFIG file to the number that this message recommends. For more information on the BUFFERPOOL parameter, see "BUFFERPOOL configuration parameter" on page 1-36..

warning: Chunk time stamps are invalid.

Cause

A sanity check is performed on chunks when they are first opened at system initialization. The chunk specified did not pass the check and will be brought offline.

Action

Restore the chunk from a dbspace backup or its mirror.

Warning: *name_old* is a deprecated onconfig parameter. Use *name_new* instead. See the release notes and the Informix Administrator's Reference for more information.

Cause

A deprecated ONCONFIG parameter was used. This message displays the first time that you use a deprecated parameter. The shorter form of the message displays thereafter.

Action

Use the suggested alternative ONCONFIG parameter.

Warning: *name_old* is a deprecated onconfig parameter. Use *name_new* instead.

Cause

A deprecated ONCONFIG parameter was used.

Action

Use the suggested alternative ONCONFIG parameter.

Warning: Unable to allocate requested big buffer of size *nn*.

Cause

The internal memory allocation for a big buffer failed.

Action

Increase either virtual memory size (SHMVIRTSIZE), the size of the added segments (SHMADD), or your total shared-memory size (SHMTOTAL).

You are turning off smart large object logging.

Cause

These changes will become the new sbspace default values. Changes have been made to the sbspace. The onspaces utility will read and update 100 smart large objects at a time and commit each block of 100 smart large objects as a single transaction. This utility might take a long time to complete.

Action

This informational message occurs when you issue the following command:

```
onspaces -ch sbspace -Df "LOGGING=OFF" -y
```

For more information, see "onspaces -ch: Change sbspace default specifications" on page 20-17.

Messages: Symbols

***HH:MM:SS* Informix database server Version *R.VV.PPPPP*
Software Serial Number *RDS#YYYYYYY*.**

Cause

This message indicate the start-up of the database server, after the initialization of shared memory.

Action

No action is required.

argument: **invalid argument.**

Cause

This internal error indicates that an invalid argument was passed to an internal routine.

Action

Contact Technical Support.

function_name: **cannot allocate memory.**

Cause

The database server cannot allocate memory from internal shared-memory pool.

Action

Increase either virtual-memory size (SHMVIRTSIZE), the size of the added segments (SHMADD), or your total shared-memory size (SHMTOTAL).

Conversion/Reversion Messages

These messages might display during database server conversion or reversion.

Messages: A-C

Cannot revert constraint with id *id* (in syschecks).

Cause

The database has a constraint that was defined in a version more recent than the one to which you are reverting.

Action

Drop the specified constraint and retry reversion.

Cannot revert new fragment expression for index *index*, tabid *id*.

Cause

The index fragmentation was defined in a version more recent than the one to which you are reverting.

Action

Drop the problem index-fragmentation scheme and retry reversion.

Cannot revert new table fragment expression for *table* with id *id*.

Cause

The fragmentation of this table was defined in a version more recent than the one to which you are reverting.

Action

Drop the problem table fragmentation scheme and retry reversion.

Cannot update page zero.**Cause**

Attempt to write page zero failed.

Action

Contact Technical Support.

Checking database *name* for revertibility.**Cause**

Indicates that start of the reversion checks on the specified database.

Action

None required.

Conversion of pre 7.3 in-place alter started *status*.**Cause**

The database server is converting data structures for in-place alters to the new format.

Action

None required.

Conversion of pre 9.2 database tablespaces *status*.**Cause**

The database server is converting tablespaces to the new format.

Action

None required.

The conversion of the database *name* has failed.**Cause**

Indicates that the conversion of the specified database has failed.

Action

Connect to the database. This action triggers conversion of the database. If it fails, the relevant error message appears. Contact Technical Support.

Converting database *name*...**Cause**

This message appears at the start of conversion of each database in the system.

Action

None required.

Converting in-place alters to new format.**Cause**

The database server is converting data structures for in-place alters to the new format.

Action

None required.

Converting 'onpload' database...**Cause**

Printed in **online.log** at the beginning of **onpload** conversion.

Action

None required.

Converting partition header from version 7.x.**Cause**

The database server is converting the partition header page to the new format that contains the chunk number and offset.

This message is optional verbose output that is logged only if you start **oninit** with the **-v** flag.

Action

None required.

Converting partition header page *address*.**Cause**

The database server is converting the partition header page to the new format that contains the chunk number and page offset.

This message is optional verbose output that is logged only if you start **oninit** with the **-v** flag.

Action

None required.

Converting partition header pages *status*.**Cause**

This message tracks the progress of the conversion of the partition header pages. The status is identified as follows:

- started
- succeeded

- FAILED

Action

If the status is started or succeeded, no action is required.

If conversion of the partition header pages failed, restart the database server. It will attempt to continue converting where it left off in the restartable conversion phase. If this action fails, diagnose the problem, restore from tape, fix the problem, and retry conversion.

Converting partition keys to 9.2.**Cause**

The database server is converting the partition keys to the Version 9.2 format.

This message is optional verbose output that is logged only if you start **oninit** with the **-v** flag.

Action

None required.

Converting partition name for *databasename:tablename*.**Cause**

The database server is converting the partition name for the *databasename:tablename*.

This message is optional verbose output that is logged only if you start **oninit** with the **-v** flag.

Action

None required.

Messages: D-F**The database *name* has been converted successfully.****Cause**

Indicates successful completion of the conversion of the specified database.

Action

None required.

Database *name* is not revertible...**Cause**

The database has failed one of the reversion checks and is not revertible.

Action

Take action to correct the error displayed as a separate message.

Database *name* is revertible...**Cause**

The database has passed all reversion checks and is revertible to the specified version.

Action

None required.

Database *name*: Must drop trigger (id = *id_number*).**Cause**

The database contains a trigger that was created in a version more recent than the one to which you are converting.

Action

Drop the trigger with the specified trigger identification number and then attempt reversion.

Database *name* SUCCESSFULLY reverted...**Cause**

Indicates the success of reversion of the specified database.

Action

None required.

... dropping sysmaster database.**Cause**

The database server is dropping sysmaster database during the reversion process.

Action

No action is required.

The dummy updates failed while converting database *name*. This may imply data corruption in the database. If so, restore the original database with the tape backup. For more information, see *output_file*.

Cause

During conversion of a database from a version earlier than Version 9.2, dummy update statements are run against the system tables in the database being converted. This message indicates failure in running one of these update statements.

Action

To retry the dummy updates, run the dummy update script for your old database server version. For instructions, refer to the *IBM Informix Migration Guide*.

If data corruption occurred, restore the original database with the tape backup. For more information, see the *IBM Informix Backup and Restore Guide*.

The dummy updates succeeded while converting database *name*.
Cause

During conversion of a database from a version earlier than Version 9.2, dummy update statements are run against the system tables in the database being converted. This message indicates successful completion of these updates.

Action

None required.

Error in slow altering a system table.
Cause

An internal error occurred while performing reversion.

Action

Contact Technical Support.

External conversion aborted due to incompatible sysmaster database.
Cause

The **sysmaster** database was not converted to the current database server version. A current **sysmaster** database is needed for external conversion to complete.

Action

Drop the **sysmaster** database and reboot the database server. It will build a new **sysmaster** database and relaunch external conversion automatically.

Messages: I-P

Internal server error.
Cause

An unexpected error occurred during database reversion.

Action

Contact Technical Support.

Must drop long identifiers in table *name* in database *name*
Cause

Identifiers greater than 18 bytes in length are not supported in the database server version to which you are reverting.

Action

Make sure that all long identifiers in the system are either dropped or renamed before you attempt reversion.

Must drop new database (*name*) before attempting reversion.
Iserrno *error_number*

Cause

The system contains a database that was created in a more recent version of the database server.

Action

Drop the new database and attempt reversion.

Must drop new user defined statistics in database *name*, iserrno
number

Cause

Some distributions in the **sysdistrib** system table use user-defined statistics. This feature is not supported in the version to which you are reverting.

Action

Ensure that no user-defined statistics are present or used in the system and then attempt reversion.

ON-Bar conversion completed successfully.

Cause

ON-Bar conversion completed successfully.

Action

None.

ON-Bar conversion failed see /tmp/bar_conv.out.

Cause

ON-Bar conversion failed.

Action

For failure details, see /tmp/bar_conv.out.

ON-Bar conversion start:

Cause

ON-Bar conversion script is now running.

Action

None.

ON-Bar reversion completed successfully.

Cause

ON-Bar reversion was completed successfully.

Action

None.

ON-Bar reversion failed see /tmp/bar_rev.out.

Cause

ON-Bar reversion failed.

Action

For failure details, see /tmp/bar_rev.out.

ON-Bar reversion start:

Cause

ON-Bar reversion script is now running.

Action

None.

ON-Bar reversion test completed successfully.

Cause

ON-Bar reversion test was completed successfully.

Action

None.

ON-Bar reversion test start:

Cause

ON-Bar reversion test script is now running.

Action

None.

'onpload' conversion completed successfully.

Cause

Displayed in `online.log` at the successful completion of `onpload` conversion.

Action

None required.

'onpload' conversion failed. For details, look in \$INFORMIXDIR/etc/conpload.out.

Cause

Conversion of the `onpload` database failed.

Action

Find out the cause of failure from `$INFORMIXDIR/etc/conpload.out`. Fix the problem before you reattempt conversion.

...'onpload' reversion completed successfully.

Cause

Printed in `online.log` at the successful completion of reversion.

Action

None required.

...'onpload' reversion failed. For details, look in \$INFORMIXDIR/etc/revpload.out.

Cause

Reversion of the `onpload` database failed.

Action

Find the cause of failure in `$INFORMIXDIR/etc/revpload.out`. Fix the problem before you reattempt reversion.

'onpload' reversion test completed successfully.

Cause

Printed in `online.log` if the `onpload` database is revertible.

Action

None required.

'onpload' reversion test start:

Cause

Printed in `online.log` at the beginning of `onpload` reversion testing.

Action

None required.

The pload database contains load/unload jobs referring to long table names, column names, or database names. These jobs will not work as expected until they are redefined.

Cause

Printed during `onpload` reversion testing if the `onpload` database contains references to long table names, column names, or database names. But the reversion will complete.

Action

Redefine the load and unload jobs in the `onpload` database that have references to long identifiers.

Messages: R-W

...reverting 'onpload' database.

Cause

Printed in `online.log` at the beginning of `onpload` reversion.

Action

None required.

Reverting partition header from version 9.2.

Cause

The database server is reverting the partition header page to the old format that contains the physical address.

This message is optional verbose output that is logged only if you start `oninit` with the `-v` flag.

Action

None required.

Reverting partition header page *address*.

Cause

The database server is reverting the partition header page to the old format that contains the physical address.

This message is optional verbose output that is logged only if you start `oninit` with the `-v` flag.

Action

None required.

Reverting partition header pages *status*.

Cause

The database server is reverting the partition header pages to the old format. The status is identified as follows:

- started
- succeeded
- FAILED

Action

If reversion of the partition header pages started or succeeded, no action is required. If reversion of the partition header pages failed, restore from a tape backup, diagnose and fix the problem, and retry conversion.

Reverting partition keys to pre 9.2.

Cause

The database server is reverting the partition keys to the pre-Version 9.2 format.

This message is optional verbose output that is logged only if you start **oninit** with the **-v** flag.

Action

None required.

Reverting partition *name* for *databasename:tablename*.

Cause

The database server is reverting the partition name for *databasename:tablename*.

This message is optional verbose output that is logged only if you start **oninit** with the **-v** flag.

Action

None required.

... reverting reserved pages.

Cause

The database server is reverting reserved pages.

Action

No action is required.

... reverting tables that underwent In-Place Alter.

Cause

The database server is reverting tables that underwent in-place alter.

Action

No action is required.

R-tree error message conversion completed successfully.

Cause

R-tree error message conversion was completed successfully.

Action

None required

R-tree error message conversion failed. (See /tmp/contree.out or %TMP%\contree.out)

Cause

R-tree error message conversion failed.

Action

See `/tmp/conR-tree.out` and `/tmp/R-tree.databases`.

R-tree error message conversion started.**Cause**

R-tree error message conversion script is now running.

Action

None required.

Reversion canceled.**Cause**

The reversion process was canceled because of errors encountered.

Action

Correct the cause of the errors, and restart reversion.

Reversion complete. Install Informix database server *version* before restarting.**Cause**

The reversion process was completed successfully.

Action

You must install the older database version.

Reversion of database *name* FAILED**Cause**

Indicates the failure of reversion of the specified database.

Action

None required.

...reverting 'syscdr' database.**Cause**

Printed in `online.log` at the beginning of Enterprise Replication reversion.

Action

None required.

...starting reversion of database *name*.**Cause**

Indicates the start of actual reversion of the specified database.

Action

None required.

There is a semi-detached index in this table, which cannot be reverted. Drop this index, and retry reversion.

Cause

A semi-detached index on this table cannot be reverted.

Action

To see the list of all semi-detached indexes, refer to the database server message log. These indexes cannot be reverted. To continue reversion, drop these semi-detached indexes and retry reversion. If needed, you will need to re-create these indexes after reversion is complete.

Unable to read reserved page *chunk:offset - reserved_page*.

Cause

Both disk pages in a given reserved page pair are bad. On the disk page, *chunk* represents the chunk number and *offset* represents the page offset for the chunk.

Action

Contact Technical Support.

WARNING: Target server version must have a certified Storage Manager installed after conversion/reversion and before bringing up server.

Cause

ON-Bar is being converted or reverted. The user must ensure that a storage manager, certified with the target database server version, is installed.

Action

None.

Conversion and Reversion Messages for Enterprise Replication

Use the **concdr.sh** script on UNIX or the **concdr.bat** script on Windows to convert Enterprise Replication and the **syscdr** database to a format for an earlier version of the database server. Use the **revcdr.sh** script on UNIX or the **revcdr.bat** script on Windows to revert Enterprise Replication and the **syscdr** database to an earlier version. These scripts write conversion and reversion messages for Enterprise Replication to the following locations:

- Output of the **concdr.sh** or **concdr.bat** script, which is standard output by default
- **concdr.out** file
- Output of the **revcdr.sh** or **revcdr.bat** script, which is standard output by default
- **revcdr.out** file
- **revtestcdr.out** file

You can find the **concdr.out**, **revcdr.out**, and **revtestcdr.out** files in **\$INFORMIXDIR/etc** on UNIX or **%INFORMIXDIR%\etc** on Windows. For more information on converting and reverting Enterprise Replication, see the *IBM Informix Migration Guide*.

CDR reversion test completed successfully.

Cause

The **syscdr** database is revertible.

Action

None required.

Prints the output of the **revcdr.sh** or **revcdr.bat** script to standard output.

CDR reversion test failed; for details look in \$INFORMIXDIR/etc/revtestcdr.out.

Cause

Enterprise Replication is not revertible.

Action

For more information, look at the messages in **revtestcdr.out**. Fix the reported problem before you attempt reversion.

Prints the output of the **revcdr.sh** or **revcdr.bat** script to standard output.

Enterprise Replication is not ready for conversion. The Control and TRG send queues should be empty for conversion/reversion to proceed.

Cause

There are elements in the control and Transaction Send Queue (also called TRG) send queues. The database server sends replicated data to the TRG queue before sending it to the target system.

Action

Wait for these queues to empty before you attempt either conversion or reversion. For more information, see the *IBM Informix Enterprise Replication Guide*.

Prints this message to **concdr.out** during conversion or to **revcdr.out** during reversion.

Enterprise Replication is not ready for conversion. The syscdr database should NOT contain old-style group definitions for conversion to succeed.

Cause

The `syscdr` database should not contain old-style group definitions for conversion to succeed.

Action

Use the `cdr delete group` command to delete the old-style groups before attempting conversion. For more information, see the *IBM Informix Enterprise Replication Guide*.

Prints this message to `concdr.out`.

Enterprise Replication should be in a stopped state for conversion/reversion to proceed.

Cause

Enterprise Replication should be in a stopped state for conversion or reversion to proceed.

Action

Stop Enterprise Replication. For more information, see the *IBM Informix Enterprise Replication Guide*.

Prints this message to `concdr.out` during conversion or to `revcdr.out` during reversion.

Reversion of 'syscdr' failed; for details look in \$INFORMIXDIR/etc/revcdr.out.

Cause

The reversion of the `syscdr` database failed.

Action

Find the cause of failure in the `revcdr.out` file, then fix the problem before you attempt reversion.

Prints the output of the `revcdr.sh` or `revcdr.bat` script to standard output.

Starting CDR reversion test...

Cause

This message displays at the beginning of Enterprise Replication reversion testing.

Prints the output of the `revcdr.sh` or `revcdr.bat` script to standard output.

Action

None required.

Starting 'syscdr' conversion...

Cause

This message displays when you run the **concdr.sh** or **concdr.bat** script to convert the **syscdr** database to a format for an earlier version of the database server.

Action

None required.

Prints the output of the **concdr.sh** or **concdr.bat** script to standard output.

Starting 'syscdr' reversion...

Cause

This message displays when you run the **revcdr.sh** or **revcdr.bat** script to revert the **syscdr** database to an earlier version.

Action

None required.

Prints the output of the **revcdr.sh** or **revcdr.bat** script to standard output.

'syscdr' conversion completed successfully.

Cause

This message displays after you complete converting Enterprise Replication and the **syscdr** database a format for an earlier version of the database server.

Action

None required.

Prints the output of the **concdr.sh** or **concdr.bat** script to standard output.

'syscdr' conversion failed. For details, look in \$INFORMIXDIR/etc/concdr.out.

Cause

Conversion of the **syscdr** database failed.

Action

If conversion fails, resolve the problem reported in **concdr.out**. Restore the **syscdr** database from backup and reattempt conversion.

Prints the output of the **concdr.sh** or **concdr.bat** script to standard output.

Syscdr should NOT contain new replicate sets for reversion to succeed.

Cause

The new replicate sets in the `syscdr` database are not compatible with older versions.

Action

Use the `cdr delete replicateset` command to delete the replicate sets. Then rerun the `revcdr.sh` or `revcdr.bat` script to reattempt reversion.

Prints this message to `revtestcdr.out`.

Syscdr should not contain replicates defined with the --floatieeee option for reversion to succeed.

Cause

Replicates have been defined with the `--floatieeee` option. You cannot revert these replicates to the older version.

Action

Use the `cdr delete replicateset` command to delete replicates defined with the `--floatieeee` option, then reattempt reversion.

Prints this message to `revtestcdr.out`.

Dynamic Log Messages

Dynamically added log file *logid* to DBspace *dbspace_number*.

Cause

The next active log file contains records of an open transaction. Whenever the database server adds a log dynamically, it logs this message. Example: Dynamically added log file 38 to DBspace 5.

Action

Complete the transaction as soon as possible.

Log file *logid* added to DBspace *dbspace_number*.

Cause

Whenever the administrator adds a log file manually, the database server logs this message. Example: Log file 97 added to DBspace 2.

Action

None required.

Log file number *logid* has been dropped from DBspace *dbspace_number*.

Cause

When you drop a newly-added log file, the database server logs this message.
Example: Log file number 204 has been dropped from DBspace 17.

Action

None required.

Log file *logid* has been pre-dropped.

Cause

When you drop a used log file, it is marked as deleted (status **D**) and cannot be used again. After you perform a level-0 backup, the database server drops this log file and can reuse the space. Example: Log file 12 has been pre-dropped.

Action

To delete the log file, perform a level-0 backup of all storage spaces.

Pre-dropped log file number *logid* has been deleted from DBspace *dbspace_number*.

Cause

After a backup, the database server deletes a pre-dropped log file and logs this message. Example: Pre-dropped log file number 12 has been deleted from DBspace 3.

Action

None required.

ALERT: Because the oldest logical log (*logid*) contains records from an open transaction (*transaction_address*), the server is attempting to dynamically add a log file. But there is no space available. Please add a DBspace or chunk. Then complete the transaction as soon as possible.

Cause

If the database server is unable to dynamically add a log file because the instance is out of space, it logs this message.

Action

Add a dbspace or chunk to an existing dbspace. Then complete the transaction as soon as possible.

ALERT: The oldest logical log (*logid*) contains records from an open transaction (*transaction_address*). Logical logging will remain blocked until a log file is added. Add the log file with the onparams `-a` command, using the `-i` (insert) option, as in: `onparams -a -d dbspace -s size -i`. Then complete the transaction as soon as possible.

Cause

If the DYNAMIC_LOGS parameter is set to 1, the database server prompts the administrator to add log files manually when they are needed.

Action

Use the `onparams -a` command with the `-i` option to add the log file after the current log file. Then complete the transaction as soon as possible.

Log file *logid* has been pre-dropped. It will be deleted from the log list and its space can be reused once you take level-0 archives of all BLOBspaces, Smart BLOBspaces and non-temporary DBspaces.

Cause

When you drop a used log file, it is marked as deleted (status **D**) and cannot be used again, and `onparams` prints this message.

Action

To delete the log file, perform a level-0 backup of all storage spaces.

Sbospace Metadata Messages

Allocated *number* pages to Metadata from chunk *number*.

Cause

The database server freed the specified number of pages from the reserved area and moved them to the metadata area of chunk *number*.

Action

None required.

Allocated *number* pages to Userdata from chunk *number*.

Cause

The database server freed the specified number of pages from the reserved area and moved them to the user-data area of chunk *number*.

Action

None required.

Freeing reserved space from chunk *number* to Metadata.

Cause

The metadata area in chunk *number* is full. The database server is trying to free space from the reserved area to the metadata area.

Action

None required.

Freeing reserved space from chunk *number* to Userdata.

Cause

The user-data area in chunk *number* is full. The database server is trying to free space from the reserved area to the user-data area.

Action

None required.

Truncate Table Messages

The table cannot be truncated if it has an open cursor or dirty readers.

Cause

You must have exclusive access to the table.

Action

Wait for dirty readers to complete or close all the open cursors and reissue the TRUNCATE TABLE command.

The table cannot be truncated. It has at least one non-empty child table with referential constraints.

Cause

You cannot truncate a table if it has child tables with referential constraints and at least one row.

Action

Empty the child tables before you truncate this table.

Appendix F. Limits in Informix

The following sections list selected capacity limits and system defaults for IBM Informix.

Limitations on UNIX Operating Systems

System-Level Parameter Limits (UNIX)

System-Level Parameters	Maximum Capacity per Computer System
IBM Informix systems per computer (Dependent on available system resources)	255
Maximum number of accessible remote sites	Machine specific
Maximum virtual shared memory segment (SHMVIRTSIZE)	2GB (32-bit platforms) or 4TB (64-bit platforms)
Maximum address space	1.7GB if boot.ini file not modified to 3GB 2.7GB if boot.ini file is modified to 3GB

Table-level parameter limits (UNIX)

Table-Level Parameters (based on 2K page size)	Maximum Capacity per Table
Data rows per page	255
Data rows per fragment	4,277,659,295
Data pages per fragment	16,775,134
Data bytes per fragment (excludes Smart Large Objects (BLOB, CLOB) and Simple Large Objects (BYTE, TEXT) created in Blobspaces)	33,818,671,136
Binary Large Object BLOB/CLOB pages	4*2*40
Binary Large Objects TEXT/BYTE bytes	4*2*40
Row length	32,767
Number of columns	32K
Key parts per index	16
Columns per functional index	102 (for C UDRs) 341 (for SPL or Java UDRs)
Maximum bytes per index key (for a given page size):	2K page size = 387 4K page size = 796 8K page size = 1615 12K page size = 2435 16K page size = 3254
Maximum size of an SQL statement	64K

Access capabilities (UNIX)

Access Capabilities	Maximum Capacity per System
Maximum databases per Informix system	21 million
Maximum tables per Informix system	477,102,080
Maximum active users per Informix (minus the minimum number of system threads)	32K user threads
Maximum active users per database and table (also limited by the number of available locks, a tunable parameter)	32K user threads
Maximum number of open databases in a session	8 databases
Maximum number of open tables per Informix system	Dynamic allocation
Maximum number of open tables per user and join	Dynamic allocation
Maximum locks per Informix system and database	Dynamic allocation
Maximum number of page cleaners	128
Maximum number of partitions per dbspace	4K page size: 1048445, 2K page size: 1048314 (based on 4-bit bitmaps)
Maximum number of recursive synonym mappings	16
Maximum number of tables locked with LOCK TABLE per user	32
Maximum number of cursors per user	Machine specific
Maximum Enterprise Replication transaction size	4 TB
Maximum dbspace size	4 TB with 2K page size 8 TB with 4K page size
Maximum sbspace size	4 TB with 2K page size 8 TB with 4K page size
Maximum chunk size	4 TB
Maximum number of chunks	32,766
Maximum number of 2K pages per chunk	2 billion
Maximum number of open Simple Large Objects (applies only to TEXT and BYTE data types)	20
Maximum number of B-tree levels	20
Maximum amount of decision support memory	Machine specific
Maximum size of an Informix instance	8 PB
Utility support for large files	17 billion GB
Maximum number of storage spaces (dbspaces, blobspaces, sbspaces, or extspaces)	2047

Informix System Defaults (UNIX)

Table lock mode	Page
Initial extent size	8 pages
Next extent size	8 pages
Read-only isolation level (with database transactions)	Committed Read

Read-only isolation level (ANSI-compliant database)	Repeatable Read
---	-----------------

ON-Monitor Statistics (UNIX)

Number of displayed user threads	1000
Number of displayed chunks	1000
Number of displayed dbspaces	1000
Number of displayed databases	1000
Number of displayed logical logs	1000

Limitations on Windows Operating Systems

System-Level Parameter Limits (Windows)

System-Level Parameters	Maximum Capacity per Computer System
IBM Informix systems per computer (Dependent on available system resources)	255
Maximum number of accessible remote sites	Machine specific
Maximum virtual shared memory segment (SHMVIRTSIZE)	2GB (32-bit platforms) or 4TB (64-bit platforms)
Maximum address space	1.7 GB if boot.ini file not modified to 3 GB 2.7 GB if boot.ini file is modified to 3 GB

Table-level parameter limits (Windows)

Table-Level Parameters (based on 2K page size)	Maximum Capacity per Table
Data rows per page	255
Data rows per fragment	4,277,659,295
Data pages per fragment	16,775,134
Data bytes per fragment (excludes Smart Large Objects (BLOB, CLOB) and Simple Large Objects (BYTE, TEXT) created in Blobspaces)	33,818,671,136
Binary Large Object BLOB/CLOB pages	4 TB
Binary Large Objects TEXT/BYTE bytes	4 TB
Row length	32,767
Number of columns	32 K
Key parts per index	16
Columns per functional index	102 (for C UDRs) 341 (for SPL or Java UDRs)

Table-Level Parameters (based on 2K page size)	Maximum Capacity per Table
Maximum bytes per index key (for a given page size):	2K page size = 387 4K page size = 796 8K page size = 1615 12K page size = 2435 16K page size = 3254
Maximum size of an SQL statement	64 K

Access Capabilities (Windows)

Access Capabilities	Maximum Capacity per System
Maximum databases per IBM Informix system	21 million
Maximum tables per IBM Informix system	477,102,080
Maximum active users per IBM Informix (minus the minimum number of system threads)	32K user threads
Maximum active users per database and table (also limited by the number of available locks, a tunable parameter)	32K user threads
Maximum number of open databases in a session	8 databases
Maximum number of open tables per IBM Informix system	Dynamic allocation
Maximum number of open tables per user and join	Dynamic allocation
Maximum locks per IBM Informix system and database	Dynamic allocation
Maximum number of page cleaners	128
Maximum number of recursive synonym mappings	16
Maximum number of tables locked with LOCK TABLE per user	32
Maximum number of cursors per user	Machine specific
Maximum Enterprise Replication transaction size	4 TB
Maximum dbspace size	8 TB
Maximum sbspace size	8 TB
Maximum chunk size	4 TB
Maximum number of chunks	32,766
Maximum number of 2K pages per chunk	2 billion
Maximum number of open Simple Large Objects (applies only to TEXT and BYTE data types)	20
Maximum number of B-tree levels	20
Maximum amount of decision support memory	Machine specific
Maximum size of a IBM Informix instance	8 PB
Utility support for large files	17 billion GB
Maximum number of storage spaces (dbspaces, blobspaces, sbspaces, or extspaces)	2047
Maximum number of partitions per dbspace	4K page size: 1048445, 2K page size: 1048314 (based on 4-bit bitmaps)

Informix System Defaults (Windows)

Table lock mode	Page
Initial extent size	8 pages
Next extent size	8 pages
Read-only isolation level (with database transactions)	Committed Read
Read-only isolation level (ANSI-compliant database)	Repeatable Read

Appendix G. Accessibility

IBM strives to provide products with usable access for everyone, regardless of age or ability.

Accessibility features for IBM Informix products

Accessibility features help a user who has a physical disability, such as restricted mobility or limited vision, to use information technology products successfully.

Accessibility features

The following list includes the major accessibility features in IBM Informix products. These features support:

- Keyboard-only operation.
- Interfaces that are commonly used by screen readers.
- The attachment of alternative input and output devices.

Keyboard navigation

This product uses standard Microsoft Windows navigation keys.

Related accessibility information

IBM is committed to making our documentation accessible to persons with disabilities. Our publications are available in HTML format so that they can be accessed with assistive technology such as screen reader software.

IBM and accessibility

See the *IBM Accessibility Center* at <http://www.ibm.com/able> for more information about the IBM commitment to accessibility.

Dotted decimal syntax diagrams

The syntax diagrams in our publications are available in dotted decimal format, which is an accessible format that is available only if you are using a screen reader.

In dotted decimal format, each syntax element is written on a separate line. If two or more syntax elements are always present together (or always absent together), the elements can appear on the same line, because they can be considered as a single compound syntax element.

Each line starts with a dotted decimal number; for example, 3 or 3.1 or 3.1.1. To hear these numbers correctly, make sure that your screen reader is set to read punctuation. All syntax elements that have the same dotted decimal number (for example, all syntax elements that have the number 3.1) are mutually exclusive alternatives. If you hear the lines 3.1 USERID and 3.1 SYSTEMID, your syntax can include either USERID or SYSTEMID, but not both.

The dotted decimal numbering level denotes the level of nesting. For example, if a syntax element with dotted decimal number 3 is followed by a series of syntax elements with dotted decimal number 3.1, all the syntax elements numbered 3.1 are subordinate to the syntax element numbered 3.

Certain words and symbols are used next to the dotted decimal numbers to add information about the syntax elements. Occasionally, these words and symbols might occur at the beginning of the element itself. For ease of identification, if the word or symbol is a part of the syntax element, the word or symbol is preceded by the backslash (\) character. The * symbol can be used next to a dotted decimal number to indicate that the syntax element repeats. For example, syntax element *FILE with dotted decimal number 3 is read as 3 * FILE. Format 3* FILE indicates that syntax element FILE repeats. Format 3* * FILE indicates that syntax element * FILE repeats.

Characters such as commas, which are used to separate a string of syntax elements, are shown in the syntax just before the items they separate. These characters can appear on the same line as each item, or on a separate line with the same dotted decimal number as the relevant items. The line can also show another symbol that provides information about the syntax elements. For example, the lines 5.1*, 5.1 LASTRUN, and 5.1 DELETE mean that if you use more than one of the LASTRUN and DELETE syntax elements, the elements must be separated by a comma. If no separator is given, assume that you use a blank to separate each syntax element.

If a syntax element is preceded by the % symbol, that element is defined elsewhere. The string following the % symbol is the name of a syntax fragment rather than a literal. For example, the line 2.1 %OP1 refers to a separate syntax fragment OP1.

The following words and symbols are used next to the dotted decimal numbers:

- ? Specifies an optional syntax element. A dotted decimal number followed by the ? symbol indicates that all the syntax elements with a corresponding dotted decimal number, and any subordinate syntax elements, are optional. If there is only one syntax element with a dotted decimal number, the ? symbol is displayed on the same line as the syntax element (for example, 5? NOTIFY). If there is more than one syntax element with a dotted decimal number, the ? symbol is displayed on a line by itself, followed by the syntax elements that are optional. For example, if you hear the lines 5 ?, 5 NOTIFY, and 5 UPDATE, you know that syntax elements NOTIFY and UPDATE are optional; that is, you can choose one or none of them. The ? symbol is equivalent to a bypass line in a railroad diagram.
- ! Specifies a default syntax element. A dotted decimal number followed by the ! symbol and a syntax element indicates that the syntax element is the default option for all syntax elements that share the same dotted decimal number. Only one of the syntax elements that share the same dotted decimal number can specify a ! symbol. For example, if you hear the lines 2? FILE, 2.1! (KEEP), and 2.1 (DELETE), you know that (KEEP) is the default option for the FILE keyword. In this example, if you include the FILE keyword but do not specify an option, default option KEEP is applied. A default option also applies to the next higher dotted decimal number. In this example, if the FILE keyword is omitted, default FILE(KEEP) is used. However, if you hear the lines 2? FILE, 2.1, 2.1.1! (KEEP), and 2.1.1 (DELETE), the default option KEEP only applies to the next higher dotted decimal number, 2.1 (which does not have an associated keyword), and does not apply to 2? FILE. Nothing is used if the keyword FILE is omitted.
- * Specifies a syntax element that can be repeated zero or more times. A dotted decimal number followed by the * symbol indicates that this syntax element can be used zero or more times; that is, it is optional and can be

repeated. For example, if you hear the line 5.1* data-area, you know that you can include more than one data area or you can include none. If you hear the lines 3*, 3 HOST, and 3 STATE, you know that you can include HOST, STATE, both together, or nothing.

Notes:

1. If a dotted decimal number has an asterisk (*) next to it and there is only one item with that dotted decimal number, you can repeat that same item more than once.
 2. If a dotted decimal number has an asterisk next to it and several items have that dotted decimal number, you can use more than one item from the list, but you cannot use the items more than once each. In the previous example, you can write HOST STATE, but you cannot write HOST HOST.
 3. The * symbol is equivalent to a loop-back line in a railroad syntax diagram.
- + Specifies a syntax element that must be included one or more times. A dotted decimal number followed by the + symbol indicates that this syntax element must be included one or more times. For example, if you hear the line 6.1+ data-area, you must include at least one data area. If you hear the lines 2+, 2 HOST, and 2 STATE, you know that you must include HOST, STATE, or both. As for the * symbol, you can repeat a particular item if it is the only item with that dotted decimal number. The + symbol, like the * symbol, is equivalent to a loop-back line in a railroad syntax diagram.

Notices

This information was developed for products and services offered in the U.S.A.

IBM may not offer the products, services, or features discussed in this document in other countries. Consult your local IBM representative for information on the products and services currently available in your area. Any reference to an IBM product, program, or service is not intended to state or imply that only that IBM product, program, or service may be used. Any functionally equivalent product, program, or service that does not infringe any IBM intellectual property right may be used instead. However, it is the user's responsibility to evaluate and verify the operation of any non-IBM product, program, or service.

IBM may have patents or pending patent applications covering subject matter described in this document. The furnishing of this document does not grant you any license to these patents. You can send license inquiries, in writing, to:

IBM Director of Licensing
IBM Corporation
North Castle Drive
Armonk, NY 10504-1785
U.S.A.

For license inquiries regarding double-byte (DBCS) information, contact the IBM Intellectual Property Department in your country or send inquiries, in writing, to:

Intellectual Property Licensing
Legal and Intellectual Property Law
IBM Japan Ltd.
1623-14, Shimotsuruma, Yamato-shi
Kanagawa 242-8502 Japan

The following paragraph does not apply to the United Kingdom or any other country where such provisions are inconsistent with local law: INTERNATIONAL BUSINESS MACHINES CORPORATION PROVIDES THIS PUBLICATION "AS IS" WITHOUT WARRANTY OF ANY KIND, EITHER EXPRESS OR IMPLIED, INCLUDING, BUT NOT LIMITED TO, THE IMPLIED WARRANTIES OF NON-INFRINGEMENT, MERCHANTABILITY OR FITNESS FOR A PARTICULAR PURPOSE. Some states do not allow disclaimer of express or implied warranties in certain transactions, therefore, this statement may not apply to you.

This information could include technical inaccuracies or typographical errors. Changes are periodically made to the information herein; these changes will be incorporated in new editions of the publication. IBM may make improvements and/or changes in the product(s) and/or the program(s) described in this publication at any time without notice.

Any references in this information to non-IBM websites are provided for convenience only and do not in any manner serve as an endorsement of those websites. The materials at those websites are not part of the materials for this IBM product and use of those websites is at your own risk.

IBM may use or distribute any of the information you supply in any way it believes appropriate without incurring any obligation to you.

Licensees of this program who wish to have information about it for the purpose of enabling: (i) the exchange of information between independently created programs and other programs (including this one) and (ii) the mutual use of the information which has been exchanged, should contact:

IBM Corporation
J46A/G4
555 Bailey Avenue
San Jose, CA 95141-1003
U.S.A.

Such information may be available, subject to appropriate terms and conditions, including in some cases, payment of a fee.

The licensed program described in this document and all licensed material available for it are provided by IBM under terms of the IBM Customer Agreement, IBM International Program License Agreement or any equivalent agreement between us.

Any performance data contained herein was determined in a controlled environment. Therefore, the results obtained in other operating environments may vary significantly. Some measurements may have been made on development-level systems and there is no guarantee that these measurements will be the same on generally available systems. Furthermore, some measurements may have been estimated through extrapolation. Actual results may vary. Users of this document should verify the applicable data for their specific environment.

Information concerning non-IBM products was obtained from the suppliers of those products, their published announcements or other publicly available sources. IBM has not tested those products and cannot confirm the accuracy of performance, compatibility or any other claims related to non-IBM products. Questions on the capabilities of non-IBM products should be addressed to the suppliers of those products.

All statements regarding IBM's future direction or intent are subject to change or withdrawal without notice, and represent goals and objectives only.

All IBM prices shown are IBM's suggested retail prices, are current and are subject to change without notice. Dealer prices may vary.

This information is for planning purposes only. The information herein is subject to change before the products described become available.

This information contains examples of data and reports used in daily business operations. To illustrate them as completely as possible, the examples include the names of individuals, companies, brands, and products. All of these names are fictitious and any similarity to the names and addresses used by an actual business enterprise is entirely coincidental.

COPYRIGHT LICENSE:

This information contains sample application programs in source language, which illustrate programming techniques on various operating platforms. You may copy,

modify, and distribute these sample programs in any form without payment to IBM, for the purposes of developing, using, marketing or distributing application programs conforming to the application programming interface for the operating platform for which the sample programs are written. These examples have not been thoroughly tested under all conditions. IBM, therefore, cannot guarantee or imply reliability, serviceability, or function of these programs. The sample programs are provided "AS IS", without warranty of any kind. IBM shall not be liable for any damages arising out of your use of the sample programs.

Each copy or any portion of these sample programs or any derivative work, must include a copyright notice as follows:

© (your company name) (year). Portions of this code are derived from IBM Corp. Sample Programs.

© Copyright IBM Corp. _enter the year or years_. All rights reserved.

If you are viewing this information softcopy, the photographs and color illustrations may not appear.

Trademarks

IBM, the IBM logo, and [ibm.com](http://www.ibm.com) are trademarks or registered trademarks of International Business Machines Corp., registered in many jurisdictions worldwide. Other product and service names might be trademarks of IBM or other companies. A current list of IBM trademarks is available on the web at "Copyright and trademark information" at <http://www.ibm.com/legal/copytrade.shtml>.

Adobe, the Adobe logo, and PostScript are either registered trademarks or trademarks of Adobe Systems Incorporated in the United States, and/or other countries.

Intel, Itanium, and Pentium are trademarks or registered trademarks of Intel Corporation or its subsidiaries in the United States and other countries.

Java and all Java-based trademarks and logos are trademarks or registered trademarks of Oracle and/or its affiliates.

Linux is a registered trademark of Linus Torvalds in the United States, other countries, or both.

Microsoft, Windows, and Windows NT are trademarks of Microsoft Corporation in the United States, other countries, or both.

UNIX is a registered trademark of The Open Group in the United States and other countries.

Other company, product, or service names may be trademarks or service marks of others.

Index

Special characters

- V option 6-1
- version option 6-1
- .conf.dbservername file A-5
- .inf.servicename file A-7
- .informix file A-6
- .infos.dbservername file
 - defined A-7
 - regenerating 15-24
- .infxdirs file A-7
- .jvpprops file A-8
- onstat utility
 - g act option 21-48
 - g all option 21-49
 - g arc option 21-52
 - g ath option 21-54
 - g buf option 21-55
 - g cat option 21-57
 - g cdr option 21-59
 - g cmsm option 21-69
 - g con option 21-71

Numerics

- 64-bit addressing
 - buffer pool 1-36
 - memory 1-135

A

- ac_config.std file A-4
- ac_msg.log file A-4
- Accessibility G-1
 - dotted decimal format of syntax diagrams G-1
 - keyboard G-1
 - shortcut keys G-1
 - syntax diagrams, reading in a screen reader G-1
- ACCESSTIME tag 20-13
- add bufferpool argument 22-13
- add chunk argument 22-14
- add log argument 22-16
- add memory argument 22-17
- add mirror argument 22-18
- ADDCHK logical-log record 5-3
- ADDDBS logical-log record 5-3
- Adding
 - CPU virtual processors 15-20, 15-22
- ADDITEM logical-log record 5-3
- ADDLOG logical-log record 5-3
- ADMIN_MODE_USERS configuration parameter 1-24
- ADMIN_USER_MODE_WITH_DBSA configuration parameter 1-25
- admin() functions 22-1
 - add bufferpool argument 22-13
 - add chunk argument 22-14
 - add log argument 22-16
 - add memory argument 22-17
 - add mirror argument 22-18
 - alter chunk argument 22-19
 - alter logmode argument 12-1, 22-20
 - admin() functions (*continued*)
 - alter plog argument 22-21
 - archive fake argument 22-21
 - argument size 22-2
 - arguments by functional category 22-4
 - cdr argument 22-22
 - check data argument 22-23
 - check extents argument 22-24
 - check partition argument 22-24
 - checkpoint argument 22-25
 - clean sbspace argument 22-26
 - compress argument 22-127
 - compression purge_dictionary argument 22-133
 - create blobspace argument 22-26
 - create blobspace from storagepool argument 22-28
 - create chunk argument 22-29
 - create chunk from storagepool argument 22-30
 - create database argument 22-31
 - create dbspace argument 22-32
 - create dbspace from storagepool argument 22-33
 - create sbspace argument 22-34
 - create sbspace from storagepool argument 22-35
 - create sbspace with accesstime argument 22-36
 - create sbspace with log argument 22-37
 - create tempdbspace argument 22-38
 - create tempdbspace from storagepool argument 22-39
 - create tempsbspace argument 22-40
 - create tempsbspace from storagepool argument 22-41
 - create_dictionary argument 22-127
 - drop blobspace argument 22-43
 - drop blobspace to storagepool argument 22-44
 - drop chunk argument 22-44
 - drop chunk to storagepool argument 22-46
 - drop database argument 22-46
 - drop dbspace argument 22-47
 - drop dbspace to storagepool argument 22-47
 - drop log argument 22-48
 - drop sbspace argument 22-49
 - drop sbspace to storagepool argument 22-49
 - drop tempdbspace argument 22-50
 - drop tempdbspace to storagepool argument 22-51
 - drop tempsbspace to storagepool argument 22-51
 - estimate_compression argument 22-127
 - command output 22-132
 - file status 22-52
 - for compressing data 22-126, 22-127
 - fragment argument 22-127
 - ha make primary argument 22-53
 - ha rss add argument 22-55
 - ha rss argument 22-54
 - ha rss change argument 22-56
 - ha rss delete argument 22-57
 - ha sds clear argument 22-57
 - ha sds primary argument 22-58
 - ha sds set argument 22-59
 - ha set idxauto argument 22-60
 - ha set ipl argument 22-60
 - ha set primary argument 22-61
 - ha set secondary argument 22-62
 - ha set standard argument 22-62
 - ha set timeout argument 22-63

- admin() functions (*continued*)
 - message log delete 22-64
 - message log rotate 22-65
 - message log truncate 22-65
 - modify chunk extend argument 22-66
 - modify chunk extendable argument 22-67
 - modify chunk extendable off argument 22-68
 - modify space expand argument 22-69
 - modify space sp_sizes argument 22-70
 - onbar argument 22-93
 - onmode and a arguments 22-72
 - onmode and c arguments 22-73
 - onmode and C arguments 22-74
 - onmode and d arguments 22-75
 - onmode and D arguments 22-77
 - onmode and e arguments 22-77
 - onmode and F arguments 22-78
 - onmode and j arguments 22-79
 - onmode and l arguments 22-80
 - onmode and m arguments 22-80
 - onmode and M arguments 22-81
 - onmode and n arguments 22-82
 - onmode and O arguments 22-82
 - onmode and p arguments 22-83
 - onmode and Q arguments 22-84
 - onmode and r arguments 22-85
 - onmode and S arguments 22-86
 - onmode and W arguments 22-86
 - onmode and wf arguments 22-88
 - onmode and wm arguments 22-89
 - onmode and Y arguments 22-91
 - onmode and z arguments 22-92
 - onmode and Z arguments 22-93
 - onmode, wm, and AUTO_LRU_TUNING arguments 22-90
 - onmsync argument 22-95
 - ontape archive argument 22-96
 - print error argument 22-97
 - print file info argument 22-98
 - print partition argument 22-99
 - rename space argument 22-99
 - repack argument 22-127
 - repack_offline argument 22-127
 - reset sysadmin argument 22-100
 - restart listen argument 22-101
 - return codes 22-2
 - scheduler argument 22-102
 - scheduler lmm disable argument 22-105
 - scheduler lmm enable argument 22-102
 - set chunk argument 22-106
 - set dataskip argument 22-107
 - set index compression argument 22-107
 - set onconfig memory argument 22-108
 - set onconfig permanent argument 22-109
 - set sbospace accesstime argument 22-110
 - set sbospace avg_lo_size argument 22-111
 - set sbospace logging argument 22-112
 - set sql tracing argument 22-112
 - set sql tracing database argument 22-114
 - set sql tracing session argument 22-115
 - set sql tracing user argument 22-116
 - set sql user tracing argument 22-116
 - shrink argument 22-127
 - start listen argument 22-117
 - start mirroring argument 22-118
 - stop listen argument 22-118
 - stop mirroring argument 22-119

- admin() functions (*continued*)
 - storagepool add argument 22-120
 - storagepool delete argument 22-122
 - storagepool modify argument 22-123
 - storagepool purge argument 22-125
 - syntax rules 22-1
 - table argument 22-127
 - uncompress argument 22-127
 - uncompress_offline argument 22-127
- Administration mode 1-24, 15-18
- af.xxx file A-4
- AFF_NPROCS configuration parameter
 - defined D-2
 - VP D-2
- AFF_SPROC configuration parameter
 - defined D-2
 - VPCLASS D-2
- alarm scripts
 - foreground operations C-2
- ALARMPROGRAM configuration parameter 1-26, C-1
- Allocating unbuffered disk space 20-5, 20-7
- ALLOCGENPG log record 5-3
- ALLOW_NEWLINE configuration parameter 1-27
- ALRM_ALL_EVENTS configuration parameter 1-28
- alter chunk argument 22-19
- alter logmode argument 12-1, 22-20
- alter plog argument 22-21
- ALTERDONE log record 5-3
- Alternate dbservername 1-44
- ALTSPCOLSNEW log record 5-3
- ALTSPCOLSOLD log record 5-3
- ANSI/ISO-compliant database property 2-15
- archive fake argument 22-21
- Archiving
 - after renaming spaces 20-26
- Assertion failure
 - af.xxx file A-4
 - DUMPCNT configuration parameter 1-66
 - DUMPSHMEM configuration parameter 1-68
 - gcore file A-6
 - shmem.xxx file A-10
- Assertion-failed messages E-2
- Asynchronous I/O
 - cooked chunks D-8
- Audit records
 - sysadinfo table 2-7
 - sysaudit table 2-7
- AUTO_AIOVPS configuration parameter 1-28
- AUTO_CKPTS configuration parameter 1-29
- AUTO_LRU_TUNING
 - changing dynamically 15-28
- AUTO_LRU_TUNING configuration parameter 1-29
- AUTO_READAHEAD configuration parameter 1-30
- AUTO_REPREPARE configuration parameter 1-31
- AUTO_STAT_MODE configuration parameter 1-32
- AVG_LO_SIZE tag 20-14

B

- B-tree
 - functional index 4-21
 - key-value locking 4-20
 - structure 4-16
- B-tree scanner 1-34, 15-5
 - controlling with SQL administration API commands 22-74
 - onmode -C command 22-74

- Backups
 - adding log files 17-2
 - after creating a storage space 20-5, 20-7, 20-16
 - automatic log 1-26, C-1
 - boot file A-5
 - changing physical log 17-4
 - displaying contents 14-1
 - dropping log files 17-2
 - external 15-4
 - ixbar file A-5
- BADIDX logical-log record 5-3
- BAR_ACT_LOG file 12-1
- bar_act.log file A-4
- bar_action table 2-6
- bar_instance table 2-6
- bar_object table 2-6
- bar_server table 2-6
- BATCHEDREAD_INDEX configuration parameter 1-33
- BATCHEDREAD_TABLE configuration parameter 1-33
- BEGCOM logical-log record 5-3
- BEGIN logical-log record 5-3
- beginlg field 21-217
- BEGPREP logical-log record 5-3
- BEGWORK logical-log record 5-3
- BFRMAP logical-log record 5-3
- Big-remainder page 4-14
- Binding CPU virtual processors D-2
- Bitmap page
 - blobspace 4-23
 - tblspace tblspace 4-5
- bitvector field 5-3
- BLDCL logical-log record 5-3
- bldutil.sh script 2-2, A-5
- Blobpage
 - average fullness statistics 9-3, 9-13
 - size, blobpage 4-21
 - size, specifying 4-21, 20-5
 - structure
 - and storage 4-21, 4-23
 - dbspace blobpage 4-22
- Blobspaces
 - adding chunk 20-2
 - bit-map page 4-23
 - blobpage structure 4-23
 - blobpage mirror chunk, structure 4-3
 - blobpage structure 4-21
 - creating 20-5
 - dropping blobspaces 20-20
 - dropping chunk 20-19
 - free-map page
 - defined 4-23
 - location in blobpage 4-21
 - role in blobpage logging 4-23
 - tracked by bitmap 4-23
 - maximum number 20-5, 20-7, 20-16
 - mirroring, ending 20-24
 - mirroring, starting 20-22
 - naming conventions 20-5
 - page types 4-23
 - restriction
 - dropping 20-20
 - simple-large-object storage 4-22
- Blocking
 - by checkpoints 21-61
 - database server 15-4
- BLOCKTIMEOUT configuration parameter 1-34
- BMAP2TO4 logical-log record 5-3
- BMAPFULL logical-log record 5-3
- BSPADD logical-log record 5-3
- BTCPYBCK logical-log record 5-3
- BTMERGE logical-log record 5-3
- BTSCANNER configuration parameter 1-34
- BTSHUFFL logical-log record 5-3
- BTSPLIT logical-log record 5-3
- Buffer pools 20-10
 - 64-bit addressing 1-36
 - adding a pool 17-4
 - creating a pool 17-4
 - smart large objects 1-36
- Buffered
 - disk space examples 20-2
- Buffered-logging database property 2-15
- BUFFERING tag
 - in -Df option 20-14
- BUFFERPOOL configuration parameter 1-36
- Buffers
 - shown with onstat -b 21-25
 - access-level flag bits 21-26
 - page-type codes 21-26
- BUFFERS discontinued configuration parameter D-3
- buffers field in the BUFFERPOOL configuration parameter 1-36
- buildsmi script
 - error log message E-17
 - failure A-5
 - initializing database server 2-1
- buildsmi_out file A-5
- buildsmi.out file A-5

C

- Case-insensitive database property 2-15
- cdr argument 22-22
- CDR logical-log record 5-3
- CHALLOC
 - logical-log record 5-3
 - record subtype (SBLOB) 5-14
- Change
 - physical log
 - size and location 17-3
- Change Data Capture (CDC) API 22-127
- Changing
 - sbspace attributes 20-17
- changing to 15-18
- CHCOMBINE
 - logical-log record 5-3
 - record subtype, SBLOB 5-14
- check data argument 22-23
- check extents argument 22-24
- check partition argument 22-24
- CHECKALLOMANSFORUSER configuration parameter 1-39
- Checkpoint
 - CKPTINTVL configuration parameter 1-40
 - disabling I/O errors 1-108
 - history 21-61
 - statistics 2-8
 - warm restores performance 1-107
- checkpoint argument 22-25
- CHFREE
 - logical-log record 5-3
 - record subtype, SBLOB 5-14
- CHKADJUP log record 5-3
- CHPHYLOG log record 5-3

- CHRESERV logical-log record 5-3
- CHSPLIT
 - logical-log record 5-3
 - record subtype, SBLOB 5-14
- chunks
 - avoid overwriting 20-28
- Chunks
 - changing mirroring status 20-27
 - checking for overlap 9-12
 - free list, checking with oncheck 9-3, 9-10
 - free-list page 4-2, 4-3, 4-4
 - initial chunk of dbspace 4-1
 - initial mirror offset 1-98
 - Logical log
 - checking consistency 9-12
 - maximum number 20-2
 - monitoring 2-8
 - Physical log
 - checking consistency 9-12
 - structure
 - additional dbspace chunk 4-3
 - initial dbspace chunk 4-2
 - mirror chunk 4-3
 - using a symbolic link for the pathname 1-99, 1-122
- CINDEX logical-log record 5-3
- Cipher
 - encryption 1-71
- CKPOINT logical-log record 5-3
- CKPTINTVL configuration parameter 1-40
- clean sbspace argument 22-26
- CLEANERS configuration parameter 1-41
- Cleaning system resources 10-1, 10-2
- Client
 - killing sessions (onmode -z) 15-30
 - results of connection D-8
 - specifying dbservername 1-46
 - USEOSTIME configuration parameter 1-164
- Clone a snapshot of a database server 19-1
- CLR logical-log record 5-3
- CLUSIDX logical-log record 5-3
- COARSELOCK log record 5-3
- Cold restore
 - number of recovery threads 1-107
- COLREPAI logical-log record 5-3
- command_history table 3-8, 22-1, 22-2
- Commands
 - onstat -g cat 21-57
 - onstat -g cdr 21-58
 - onstat -g ddr 21-74
 - onstat -g dss 21-84
- COMMIT logical-log record 5-3
- Compactness of index page 1-81
- compliance with standards xxxv
- Compressing
 - Compressing
 - fragments 22-127
 - Compression
 - dictionary 22-127
 - fragments 22-126
 - tables 22-126, 22-127
- Compression
 - dictionaries 21-131
 - fragment SQL administration API arguments 22-127
 - printing progress 21-79
 - table SQL administration API arguments 22-127
- compression purge_dictionary argument 22-133
- Compressiondeleting dictionaries 22-133
- Compressionestimating benefit 22-132
- Compressionprinting dictionary information 21-131
- COMTAB logical-log record 5-3
- COMWORK log record 5-3
- concdr.out file E-61
- concdr.sh script A-1, A-5, E-61
- Concurrent I/O
 - enabling 1-54
- Concurrent IO 1-54
- Configurable page size 1-36
- Configuration file
 - and genoncfg utility 8-1
 - displaying settings 1-2
 - preparing 1-2
 - processing A-9
 - warning about modifying onconfig.std 1-2, A-8
- Configuration parameter
 - ENCRYPT_MAC 1-73
 - ENCRYPT_MACFILE 1-74
- configuration parameter settings 1-34
- configuration parameters
 - changing dynamically 15-26
 - changing with omode -wf or -wm 15-26
 - WSTATS 1-170
- Configuration parameters
 - ADMIN_MODE_USERS 1-24
 - ADMIN_USER_MODE_WITH_DBSA 1-25
 - AFF_NPROCS D-2
 - AFF_SPROC D-2
 - ALARMPROGRAM 1-26, C-1
 - ALLOW_NEWLINE 1-27
 - ALRM_ALL_EVENTS 1-28
 - Assertion failure
 - DUMPCORE configuration parameter 1-67
 - AUTO_AIOVPS 1-28
 - AUTO_CKPTS 1-29
 - AUTO_LRU_TUNING 1-29
 - AUTO_READAHEAD 1-30
 - AUTO_REPREPARE 1-31
 - AUTO_STAT_MODE 1-32
 - BATCHEDREAD_INDEX 1-33
 - BATCHEDREAD_TABLE 1-33
 - BLOCKTIMEOUT 1-34
 - BTSCANNER 1-34
 - BUFFERPOOL 1-36
 - CHECKALLDOMAINSFORUSER 1-39
 - CKPTINTVL 1-40
 - CLEANERS 1-41
 - CONSOLE 1-41
 - CONVERSION_GUARD 1-42
- Core dump
 - DUMPCORE parameter 1-67
- current default values 1-2
- DATASKIP 1-42, 22-107
- DB_LIBRARY_PATH 1-44
- DBCREATE_PERMISSION 1-43
- DBSERVERALIASES 1-44, 15-7, 22-75
- DBSERVERNAME 1-46, 15-7, 22-75
- DBSPACETEMP 1-47
- DD_HASHMAX 1-50
- DD_HASHSIZE 1-50
- DEADLOCK_TIMEOUT 1-50
- DEF_TABLE_LOCKMODE 1-51
- DEFAULTESCCHAR 1-52
- DELAY_APPLY 1-53
- DIRECT_IO 1-54
- DIRECTIVES 1-55

Configuration parameters (continued)

DISABLE_B162428_XA_FIX 1-55
 discontinued D-1
 DRAUTO 1-57
 DRDA_COMMBUFFSIZE 1-56
 DRIDXAUTO 1-58
 DRINTERVAL 1-58
 DRLOSTFOUND 1-59
 DRTIMEOUT 1-59
 DS_HASHSIZE 1-60, 1-64
 DS_MAX_QUERIES 1-61, 15-12
 DS_MAX_SCANS 1-62, 15-12
 DS_NONPDQ_QUERY_MEM 1-63
 DS_POOLSIZE 1-64
 DS_TOTAL_MEMORY 1-64, 15-12
 DUMPCNT 1-66
 DUMPCORE 1-67
 DUMPPDIR 1-67
 DUMPSHMEM 1-68
 DYNAMIC_LOGS 1-69
 EILSEQ_COMPAT_MODE 1-70
 ENABLE_SNAPSHOT_COPY 1-71
 ENCRYPT_CIPHERS 1-71
 ENCRYPT_HDR 1-73
 ENCRYPT_SMX 1-75
 ENCRYPT_SWITCH 1-76
 EXPLAIN_STAT 1-76
 EXT_DIRECTIVES 1-77
 EXTSHMADD 1-78
 FAILOVER_CALLBACK 1-79
 FAILOVER_TX_TIMEOUT 1-79
 FAST_RESTART_CKPT_FUZZYLOG D-4
 FAST_RESTART_PHYSLOG D-4
 FASTPOLL 1-80
 FILLFACTOR 1-81, 4-20
 FULL_DISK_INIT 1-81
 HA_ALIAS 1-82
 HETERO_COMMIT 1-83
 IFX_EXTEND_ROLE 1-83
 IFX_FOLDVIEW 1-84
 JDKVERSION D-5
 JVPDEBUG A-8
 JVPLOGFILE A-8
 LIMITNUMSESSIONS 1-85
 LISTEN_TIMEOUT 1-86
 LOCKS 1-87
 LOG_INDEX_BUILDS 1-89, 22-60
 LOG_STAGING_DIR 1-90
 LOGBUFF 1-87
 LOGFILES 1-88
 LOGSIZE 1-91
 LOW_MEMORY_MGR 1-91
 LOW_MEMORY_RESERVE 1-92
 LTXEHWM 1-93
 LTXHWM 1-94
 MAX_FILL_DATA_PAGES 1-95
 MAX_INCOMPLETE_CONNECTIONS 1-96
 MAX_PDQPRIORITY 1-96, 15-12
 MIRROR 1-98
 MIRROROFFSET 1-98
 MIRRORPATH 1-99
 MSG_DATE 1-99
 MSGPATH 1-100
 MULTIPROCESSOR 1-100
 NET_IO_TIMEOUT_ALARM 1-101
 NETTYPE 1-101
 no longer used D-1

Configuration parameters (continued)

NS_CACHE 1-105
 NUMAIOVPS D-8
 NUMCPUVPS D-8
 NUMFDSERVERS 1-106
 OFF_RECVRY_THREADS 1-107
 ON_RECVRY_THREADS 1-107
 ONDBSPACEDOWN 1-108, 15-20, 22-82
 ONLIDX_MAXMEM 1-109
 OPCACHEMAX 1-109
 OPT_GOAL 1-110, 1-111
 OPTCOMPIND 1-110
 PC_HASHSIZE 1-112
 PC_POOLSIZE 1-112
 PHYSBUFF 1-113
 PHYSDBS D-9
 PHYSFILE 1-114
 PLOG_OVERFLOW_PATH 1-114
 PN_STAGEBLOB_THRESHOLD 1-115
 PRELOAD_DLL_FILE 1-115
 QSTATS 1-116
 RA_PAGES 1-116
 REMOTE_SERVER_CFG 1-117, 1-125
 REMOTE_USERS_CFG 1-118
 RESIDENT 1-119
 RESTARTABLE_RESTORE 1-120
 RESTORE_POINT_DIR 1-121
 ROOTOFFSET 1-122
 ROOTPATH 1-122
 ROOTSIZE 1-123
 RSS_FLOW_CONTROL 1-123
 RTO_SERVER_RESTART 1-125
 S6_USE_REMOTE_SERVER_CFG 1-125
 SB_CHECK_FOR_TEMP 1-126
 SBSPACENAME 1-127, 1-157
 SBSPACETEMP 1-129, 20-13
 SDS_ENABLE 1-129
 SDS_LOGCHECK 1-130
 SDS_PAGING 1-131
 SDS_TEMPDBS 1-131
 SDS_TIMEOUT 1-133
 SECURITY_LOCALCONNECTION 1-133
 SEQ_CACHE_SIZE 1-134
 SERVERNUM 1-134
 setting decision-support with onmode 15-12
 SHMADD 1-135, 22-72
 SHMBASE 1-136
 SHMNOACCESS 1-136
 SHMTOTAL 1-137
 SHMVIRT_ALLOCSEG 1-138
 SHMVIRT_SIZE 1-139
 SINGLE_CPU_VP 1-141
 SMX_COMPRESS 1-142
 SP_AUTOEXPAND 1-143
 SP_THRESHOLD 1-143
 SP_WAITTIME 1-144
 SQL_LOGICAL_CHAR 1-145
 SQLTRACE 1-147
 SSL_KEYSTORE_LABEL 1-148
 STACKSIZE 1-149
 STAGEBLOB 1-150
 STATCHANGE 1-150
 STMT_CACHE 1-151
 STMT_CACHE_HITS 1-152, 15-25
 STMT_CACHE_NOLIMIT 1-152
 STMT_CACHE_NUMPOOL 1-153
 STMT_CACHE_SIZE 1-153

Configuration parameters *(continued)*

- STOP_APPLY 1-154
- STORAGE_FULL_ALARM 1-155
- SYALARMPROGRAM 1-156
- SYSSBSPACENAME 1-157
- TBLSPACE_STATS 1-158
- TBLTBLFIRST 1-159
- TBLTBLNEXT 1-159
- TEMPTAB_NOLOG 1-160
- TXTIMEOUT 1-161, 15-31
- UNSECURE_ONSTAT 1-161
- UPDATABLE_SECONDARY 1-162
- USELASTCOMMITTED 1-163
- USEOSTIME 1-164
- USTLOW_SAMPLE 1-166
- viewing Enterprise Replication settings 21-59
- VP_MEMORY_CACHE_KB 1-166
- VPCLASS 1-167, 15-20

Configuring secure connections 18-3

Connection Manager

- configuring 11-1
- failover processing 11-1
- oncmsm 11-1
- tables
 - syscmsm 2-12
 - syscmsmsla 2-13
 - syscmsmtab 2-13

CONSOLE configuration parameter 1-41

controlling with onmode -C 15-5

Conversion messages

- database server E-49, E-61
- Enterprise Replication E-61, E-65

CONVERSION_GUARD configuration parameter 1-42

Core dump

- contained in core file A-5

core.pid.cnt file 1-67

CPU

- time tabulated 21-200

CPU virtual processor

- binding D-2
- SINGLE_CPU_VP parameter 1-141

create blobspace argument 22-26

create chunk argument 22-29

create database argument 22-31

create dbspace argument 22-32

CREATE FUNCTION statement 1-167

CREATE INDEX statement

- using FILLFACTOR 1-81

CREATE record subtype (SBLOB) 5-14

create sbspace argument 22-34

create sbspace with accesstime argument 22-36

create sbspace with log argument 22-37

create tempdbspace argument 22-38

create tempdbspace argument 22-40

Creating

- buffer pool 17-4

curllog field 21-217

D

daemon.log A-7

Data distributions

- sbspaces 1-157

Data pages

- number to read ahead 1-116

- oncheck -cd 9-8

- oncheck -cD 9-8

Data pages *(continued)*

- oncheck -cd and -cD 9-3

Data replication

- dr.lostfound file 1-59
- ENCRYPT_CIPHERS 1-71
- ENCRYPT_HDR 1-73
- ENCRYPT_MAC 1-73
- ENCRYPT_MACFILE 1-74
- ENCRYPT_SMX 1-75
- ENCRYPT_SWITCH 1-76

Files

- dr.lostfound 1-59
- flush interval 1-58
- information in sysdri table 2-17
- lost-and-found file 1-59
- wait time for response 1-59

Data row

- big-remainder page 4-14
- forward pointer 4-13
- home page 4-13, 4-14
- locating the row 4-13
- rowid 4-13
- storage strategies 4-12
- storing data on a page 4-14
- TEXT and BYTE data descriptor 4-22

Data-dictionary cache 1-50

Data-distribution cache

- specifying
 - entries 1-64
 - hash buckets 1-60

database server

- monitor status 21-19

Database servers

- blocking 15-4
- bringing online from quiescent mode 15-16, 15-17
- name 1-46
- parallel database query 15-20
- quiescent mode 15-16, 15-17
- remote 2-36
- shutting down 15-16, 15-17
- unblocking 15-4, 22-73

Database tblspace

- entries 4-7
- location in root dbspace 4-1, 4-7
- relation to systable 4-27
- structure and function 4-7
- tblspace number 4-7

Databases

- Database properties 2-15
- effect of creation 4-27
- locale, in sysdbslocale table 2-16
- owner, in sysmaster database 2-15
- sysdatabases table 2-15

DATASKIP configuration parameter 22-107

- defined 1-42
- using onspaces -f 20-21

DB_LIBRARY_PATH configuration parameter 1-44

DB_LOCALE environment variable 1-145

DBC_CREATE_PERMISSION configuration parameter 1-43

DBSERVERALIASES configuration parameter 22-75

- defined 1-44
- using onmode -d 15-7

DBSERVERNAME configuration parameter 22-75

- defined 1-46
- using onmode -d 15-7

dbspaces

- adding chunk 20-2

- dbspaces (*continued*)
 - blobpage structure 4-22
 - creating
 - with onspaces 20-7
 - dropping
 - chunk 20-19
 - with onspaces 20-20
 - ending mirroring 20-24
 - list of structures contained 4-2
 - maximum number 20-5, 20-7, 20-16
 - modifying with onspaces 20-21
 - monitoring with SMI 2-16
 - naming conventions 20-7
 - root name 1-122
 - simple-large-object storage 4-22
 - starting mirroring 20-22
 - storage 4-1
 - structure
 - additional dbspace chunk 4-3
 - chunk free-list page 4-4
 - dbspace 4-1, 4-2
 - mirror chunk 4-3
 - nonroot dbspace 4-2
 - tblspace tblspace 4-4
- DBSPACETEMP configuration parameter 1-47
- DD_HASHMAX configuration parameter 1-50
- DD_HASHSIZE configuration parameter 1-50
- Deadlock 1-50
- DEADLOCK_TIMEOUT configuration parameter 1-50
- Decision-support queries
 - DS_MAX_QUERIES configuration parameter 1-61
 - DS_TOTAL_MEMORY configuration parameter 1-64
 - gate information 21-116
 - gate numbers 21-116
 - MAX_PDQPRIORITY configuration parameter 1-96
 - setting parameters with onmode 15-12
- DEF_TABLE_LOCKMODE configuration parameter 1-51
- Default configuration file 1-2, A-9
- DEFAULTESCCHAR configuration parameter 1-52
- defragment
 - function syntax 22-42
- DELAY_APPLY configuration parameter 1-53
- DELETE
 - logical-log record 5-3
 - record subtype, SBLOB 5-14
- DELITEM logical-log record 5-3
- DERASE logical-log record 5-3
- Descriptor, TEXT and BYTE data 4-22
- DFADDEXT log record 5-3
- DFDRPEXT log record 5-3
- DFEND log record 5-3
- DFMVPG log record 5-3
- DFREMDUM log record 5-3
- DFSTART log record 5-3
- Diagnostic
 - using onmode B-1
- DINDEX logical-log record 5-3
- Direct I/O
 - enabling 1-54
- DIRECT_IO configuration parameter 1-54
- DIRECTIVES configuration parameter 1-55
- Disabilities, visual
 - reading syntax diagrams G-1
- Disability G-1
- DISABLE_B162428_XA_FIX configuration parameter 1-55
- Disabling SQL statement cache 15-14
- Disk I/O
 - buffers 1-36
 - PDQ resources 1-96
- Disk page
 - page compression 4-15
 - storing data on a page 4-14
 - structure
 - blobspace blobpage 4-8
 - dbspace page 4-12
 - types of pages in an extent 4-8, 4-9
- Disk space
 - allocating
 - for system catalogs 4-27
 - when a database is created 4-27
 - when a table is created 4-28
 - chunk free-list page 4-4
 - initializing (oninit -i) 13-1
 - list of structures 4-1
 - maximum chunk size 20-2, 20-5, 20-7, 20-12, 20-16
 - page compression 4-15
 - tracking available space in
 - blobspace 4-23
 - chunk 4-4
- Distributed transactions
 - killing 15-31
- Dotted decimal format of syntax diagrams G-1
- DRAUTO configuration parameter 1-57
- DRDA_COMMBUFFSIZE 1-56
- DRIDXAUTO configuration parameter 1-58
- DRINTERVAL configuration parameter 1-58
- DRLOSTFOUND configuration parameter 1-59
- drop blobpage argument 22-43
- drop chunk argument 22-44
- drop database argument 22-46
- drop dbspace argument 22-47
- DROP DISTRIBUTIONS keyword 1-157
- drop log argument 22-48
- drop sbspace argument 22-49
- drop tempdbspace argument 22-50
- DRPBSP logical-log record 5-3
- DRPCHK logical-log record 5-3
- DRPDBS logical-log record 5-3
- DRPLOG logical-log record 5-3
- DRTIMEOUT configuration parameter 1-59
- DS_HASHSIZE configuration parameter 1-60, 1-64
- DS_MAX_QUERIES configuration parameter
 - changing value 15-12
 - defined 1-61
- DS_MAX_SCANS configuration parameter
 - changing value 15-12
 - defined 1-62
- DS_NONPDQ_QUERY_MEM configuration parameter 1-63
- DS_POOLSIZE configuration parameter 1-64
- DS_TOTAL_MEMORY configuration parameter
 - changing value 15-12
 - defined 1-64
- DUMPCNT configuration parameter 1-66
- DUMPCORE configuration parameter 1-67
- DUMPDIR configuration parameter
 - af.xxx assertion failure file A-4
 - defined 1-67
 - gcore file A-6
 - shmem file A-10
- DUMPSHMEM configuration parameter 1-68
 - with onstat -o 21-198
- Dynamic log messages E-65, E-67
- DYNAMIC_LOGS configuration parameter 1-69

E

- EILSEQ_COMPAT_MODE configuration parameter 1-70
- Emergency boot file A-5
- ENABLE_SNAPSHOT_COPY configuration parameter 1-71
- Enabling SQL statement cache 15-14
- ENCRYPT_CIPHERS configuration parameter 1-71
- ENCRYPT_HDR configuration parameter 1-73
- ENCRYPT_MAC configuration parameter 1-73
- ENCRYPT_MACFILE configuration parameter 1-74
- ENCRYPT_SMX configuration parameter 1-75
- ENCRYPT_SWITCH configuration parameter 1-76
- Encrypting or decrypting files 18-1
- Encryption
 - cipher renegotiation 1-76
 - high-availability data replication 1-73
 - MAC files, specifying 1-74
 - message authentication code generation 1-73
 - specifying ciphers and modes 1-71
- ENDTRANS logical-log record 5-3
- Enterprise Replication
 - CDR log record 5-3
 - messages E-61, E-65
 - renaming spaces 20-26
 - SQL administration API functions 22-22
- Environment configuration file A-6
- environment variable
 - setting 1-2
- Environment variables
 - DB_LOCALE 1-145
 - IFX_BATCHEDREAD_TABLE 1-33
 - IFX_DEF_TABLE_LOCKMODE 1-51
 - IFX_DIRECTIVES 1-55, 1-77
 - IFX_XASTDCOMPLIANCE_XAEND 1-55
 - INFORMIXOPCACHE 1-109
 - INFORMIXSERVER 1-46, 15-24
 - onconfig
 - setting 1-2
 - ONCONFIG
 - defined A-9
 - onstat -c 21-28
 - OPTCOMPIND 1-110
 - SERVER_LOCALE 21-86
 - STMT_CACHE 1-151, 15-14
 - viewing Enterprise Replication settings 21-59
- ERASE logical-log record 5-3
- Error messages
 - finderr utility 7-1
 - program on Windows 7-1
- Errors
 - troubleshooting B-1
- Event alarm
 - ALARMPROGRAM parameter 1-26, C-1
 - automatic log backup C-1
 - creating 2-3
 - defined C-1
 - using ex_alarm.sh C-1
 - writing your own script C-1
- Event alarms
 - automatic log backup 1-26
 - class message parameter C-4
 - Connection Manager C-57
 - exit code C-3
 - ID parameter C-4
 - Informix C-6
 - messages C-6, C-57
 - ph_alert table C-3
 - see also parameter C-4

- Event alarms (*continued*)
 - severity 5 C-53
 - severity codes C-4
 - specific message parameter C-4
- event classes 2-32
- Event severity codes C-4
- ex_alarm.sh script 1-26, C-1
- Exclusive-access, high-water mark 1-93
- EXECUTE FUNCTION statement 22-1
- EXIT_STATUS exit code C-3
- EXPLAIN_STAT configuration parameter 1-76
- EXT_DIRECTIVES configuration parameter 1-77
- EXTDIRECTIVES session environment variable 1-77
- EXTEND record subtype, SBLOB 5-14
- EXTENT_SIZE tag 20-15
- Extents
 - automatic doubling of size 4-11
 - default size 4-8
 - disk page types 4-8, 4-9
 - merging 4-11
 - next-extent, allocating 4-10, 4-11
 - procedure for allocating 4-10
 - size
 - index fragments 4-8
 - initial extent 4-7
 - next extent 4-10
 - structure 4-7
 - sysextents table 2-18
- External backup
 - commands 15-4
- EXTSHMADD configuration parameter 1-78
- Extspace
 - creating 20-16
 - dropping 20-20
 - naming conventions 20-16
 - specifying location 20-16
 - sysextspaces table 2-19

F

- Failover processing 11-1
- FAILOVER_CALLBACK configuration parameter
 - defined 1-79
- FAILOVER_TX_TIMEOUT configuration parameter 1-79
- FAST_RESTART_CKPT_FUZZYLOG configuration parameter D-4
- FAST_RESTART_PHYSLOG configuration parameter D-4
- FASTPOLL configuration parameter
 - defined 1-80
- Files
 - .conf.dbservername A-5
 - .inf.servicename A-7
 - .informix A-6
 - .infos.dbservername A-7
 - .infxdirs A-7
 - javpprops A-8
 - ac_config.std A-4
 - ac_msg.log A-4
 - archecker configuration file A-4
 - bar_act.log A-4
 - buildsmi_out A-5
 - buildsmi.out A-5
 - core.pid.cnt 1-67, A-5
 - default configuration file A-9
 - gcore 1-67, A-6
 - informix.rc environment file A-6
 - INFORMIXTMP directory A-6

- Files *(continued)*
 - JVM_vpid A-8
 - JVPLOG A-8
 - oncfg* A-9
 - ONCONFIG A-9
 - private environment file A-6
 - shmem.pid.cnt 1-68
 - shmem.xxx A-10
 - sm_versions A-10
 - summary of database server files A-1
 - VP.servername.nnx A-11
 - xbsa.messages A-11
- FILLFACTOR configuration parameter
 - control how indexes fill 4-20
 - defined 1-81
- finderr utility 7-1, 22-97
- Flushing
 - data-replication buffer 1-58
 - SQL statement cache 15-14
- Force option, onspaces 20-20
- Forced residency
 - starting and ending with onmode 15-19
- Forest of trees indexes 4-16
- Formula
 - quantum of memory 21-116
- Forward pointer
 - blobspace blobpage 4-23
 - dbspace storage of simple large objects 4-22
 - defined 4-13
- Fragment
 - index 4-8
 - internal structure of tables 4-15
 - rowids 4-13
 - table, using primary keys 4-14
 - turning DATASKIP ON or OFF for 20-21
 - warning returned when skipped during query 1-42
- Fragment-level statistics 1-157
- FREE_RE logical-log record 5-3
- Free-map page, blobspace 4-23
- Freeing
 - blobpages 21-34
 - unused memory segments 15-14
- FULL_DISK_INIT configuration parameter 1-81
- Functional index 4-21
- Functions, SQL administration API
 - add bufferpool argument 22-13
 - add chunk argument 22-14
 - add log argument 22-16
 - add memory argument 22-17
 - add mirror argument 22-18
 - admin() 22-1
 - argument size 22-2
 - return codes 22-2
 - syntax rules 22-1
 - alter chunk argument 22-19
 - alter logmode argument 12-1, 22-20
 - alter plog argument 22-21
 - archive fake argument 22-21
 - arguments by functional category 22-4
 - cdr argument 22-22
 - check data argument 22-23
 - check extents argument 22-24
 - check partition argument 22-24
 - checkpoint argument 22-25
 - clean sbspace argument 22-26
 - compress argument 22-127
 - compression purge_dictionary argument 22-133
- Functions, SQL administration API *(continued)*
 - create blobspace argument 22-26
 - create blobspace from storagepool argument 22-28
 - create chunk argument 22-29
 - create chunk from storagepool argument 22-30
 - create database argument 22-31
 - create dbspace argument 22-32
 - create dbspace from storagepool argument 22-33
 - create sbspace argument 22-34
 - create sbspace from storagepool argument 22-35
 - create sbspace with accesstime argument 22-36
 - create sbspace with log argument 22-37
 - create tempdbspace argument 22-38
 - create tempdbspace from storagepool argument 22-39
 - create tempsbspace argument 22-40
 - create tempsbspace from storagepool argument 22-41
 - create_dictionary argument 22-127
 - drop blobspace argument 22-43
 - drop blobspace to storagepool argument 22-44
 - drop chunk argument 22-44
 - drop chunk to storagepool argument 22-46
 - drop database argument 22-46
 - drop dbspace argument 22-47
 - drop dbspace to storagepool argument 22-47
 - drop log argument 22-48
 - drop sbspace argument 22-49
 - drop sbspace to storagepool argument 22-49
 - drop tempdbspace argument 22-50
 - drop tempdbspace to storagepool argument 22-51
 - drop tempsbspace to storagepool argument 22-51
 - estimate_compression argument 22-127
 - command output 22-132
 - file status 22-52
 - for compressing data 22-126, 22-127
 - fragment argument 22-127
 - ha make primary argument 22-53
 - ha rss add argument 22-55
 - ha rss argument 22-54
 - ha rss change argument 22-56
 - ha rss delete argument 22-57
 - ha sds clear argument 22-57
 - ha sds primary argument 22-58
 - ha sds set argument 22-59
 - ha set idxauto argument 22-60
 - ha set ipl argument 22-60
 - ha set primary argument 22-61
 - ha set secondary argument 22-62
 - ha set standard argument 22-62
 - ha set timeout argument 22-63
 - message log delete 22-64
 - message log rotate 22-65
 - message log truncate 22-65
 - modify chunk extend argument 22-66
 - modify chunk extendable argument 22-67
 - modify chunk extendable off argument 22-68
 - modify space expand argument 22-69
 - modify space sp_sizes argument 22-70
 - onbar argument 22-93
 - onmode and a arguments 22-72
 - onmode and c arguments 22-73
 - onmode and C arguments 22-74
 - onmode and d arguments 22-75
 - onmode and D arguments 22-77
 - onmode and e arguments 22-77
 - onmode and F arguments 22-78
 - onmode and j arguments 22-79
 - onmode and l arguments 22-80

Functions, SQL administration API (continued)

- onmode and m arguments 22-80
- onmode and M arguments 22-81
- onmode and n arguments 22-82
- onmode and O arguments 22-82
- onmode and p arguments 22-83
- onmode and Q arguments 22-84
- onmode and r arguments 22-85
- onmode and S arguments 22-86
- onmode and W arguments 22-86
- onmode and wf arguments 22-88
- onmode and wm arguments 22-89
- onmode and Y arguments 22-91
- onmode and z arguments 22-92
- onmode and Z arguments 22-93
- onmode, wm, and AUTO_LRU_TUNING arguments 22-90
- onmsync argument 22-95
- ontape archive argument 22-96
- print error argument 22-97
- print file info argument 22-98
- print partition argument 22-99
- rename space argument 22-99
- repack argument 22-127
- repack_offline argument 22-127
- reset sysadmin argument 22-100
- restart listen argument 22-101
- scheduler argument 22-102
- scheduler lmm disable argument 22-105
- scheduler lmm enable argument 22-102
- set chunk argument 22-106
- set dataskip argument 22-107
- set index compression argument 22-107
- set onconfig memory argument 22-108
- set onconfig permanent argument 22-109
- set sbspace accesstime argument 22-110
- set sbspace avg_lo_size argument 22-111
- set sbspace logging argument 22-112
- set sql tracing argument 22-112
- set sql tracing database argument 22-114
- set sql tracing session argument 22-115
- set sql tracing user argument 22-116
- set sql user tracing argument 22-116
- shrink argument 22-127
- start listen argument 22-117
- start mirroring argument 22-118
- stop listen argument 22-118
- stop mirroring argument 22-119
- storagepool add argument 22-120
- storagepool delete argument 22-122
- storagepool modify argument 22-123
- storagepool purge argument 22-125
- table argument 22-127
- task() 22-1
 - argument size 22-2
 - return codes 22-2
 - syntax rules 22-1
- uncompress argument 22-127
- uncompress_offline argument 22-127

G

- Gateway transactions 1-83
- gcore
 - file A-6
 - utility 1-66
- genoncfg utility 8-1

- Global Security Kit 1-82
- Global transactions
 - using onstat -G 21-187
 - using onstat -x 21-217
- GLS-locale database property 2-15
- GSKCapiCmd 1-82
- GSKCmd 1-82
- GSKikm 1-82

H

- ha make primary argument 22-53
- ha rss add argument 22-55
- ha rss argument 22-54
- ha rss change argument 22-56
- ha rss delete argument 22-57
- ha sds clear argument 22-57
- ha sds primary argument 22-58
- ha sds set argument 22-59
- ha set idxauto argument 22-60
- ha set ipl argument 22-60
- ha set primary argument 22-61
- ha set secondary argument 22-62
- ha set standard argument 22-62
- ha set timeout argument 22-63
- HA_ALIAS configuration parameter
 - defined 1-82
- Hash buckets
 - data-dictionary cache 1-50
 - data-distribution cache
 - specifying hash buckets 1-60
- HDELETE logical-log record 5-3
- HDRUPD record subtype, SBLOB 5-14
- HETERO_COMMIT configuration parameter 1-83
- Heterogeneous-commit transactions 1-83
- HEURTX logical-log record 5-3
- High-water mark, transaction 1-94
- HINSERT logical-log record 5-3
- Home page 4-13, 4-14
- HUPAFT logical-log record 5-3
- HUPBEF logical-log record 5-3
- HUPDATE logical-log record 5-3

I

- I/O
 - lightweight 20-14
- IBM Informix Server Administrator
 - adding or dropping logs 1-88
 - defined 6-2
 - setting onconfig parameters 1-2
- IBM Informix STAR queries 21-215
- IBM Informix Storage Manager
 - catalog A-7
 - ISMversion file A-8
 - logs A-7
- Identifier, defined 1-46
- IDXFLAGS logical-log record 5-3
- ifx_allow_newline() routine 1-27
- IFX_BATCHEDREAD_TABLE environment variable 1-33
- IFX_DEF_TABLE_LOCKMODE environment variable 1-51
- IFX_DIRECTIVES environment variable 1-55, 1-77
- IFX_EXTEND_ROLE configuration parameter 1-83
- IFX_FOLDVIEW configuration parameter 1-84
- ifx_lo_specset_estbytes function 20-15
- ifx_lo_stat function 20-18

IFX_XASTDCOMPLIANCE_XAEND environment variable 1-55

ifxclone utility 19-1

ifxcollect tool B-2

IKEYCMD 1-82

iKeyman 1-82

illsrta.xx file A-6

Index

- branch node 4-16
- configuration 4-20
- duplicate key values 4-19
- forest of trees 4-16
- functional 4-21
- how created and filled 4-17
- key value locking 4-20
- leaf node 4-16
- reuse of freed pages 4-20
- root node 4-16
- structure of B-tree 4-16

Index item

- calculating the length of 4-20

Index page

- compactness 1-81
- creation of first 4-17
- effect of creation 4-17
- structure 4-16

indexes

- defragmenting 22-42

industry standards xxxv

Information

- SQL profile 2-41

informix.rc environment file A-6

INFORMIXOPCACHE environment variable 1-109

INFORMIXSERVER environment variable 1-44, 1-46, 15-24

INFORMIXTMP directory A-6, A-7

Initializing

- disk structures 4-1

INSERT logical-log record 5-3

InstallServer.log file A-7

Interrupt signal 6-1

Interval

- checkpoint 1-40

ISA. 1-88

ISM.

- See IBM Informix Storage Manager. A-7

ISMversion file A-8

ISOSPCOMMIT log record 5-3

J

JDKVERSION discontinued configuration parameter D-5

JDKVERSION parameter D-5

JVM_vpid file A-8

JVPDEBUG configuration parameter A-8

JVPLOG file A-8

JVPLOGFILE configuration parameter A-8

K

Key value

- checking order with oncheck 9-3, 9-11
- duplicates 4-19
- locking 4-20

Key-only

- inserting entries 1-152, 15-25

Killing a session 15-30

L

Large chunk mode 15-3

Latch

- displaying with onstat -s 21-22, 21-209
- identifying the resource controlled 21-209

LBU_PRESERVE discontinued configuration parameter D-5

LCKLVL logical-log record 5-3

LG_ADDBPOOL logical-log record 5-3

LG_CDINDEX log record 5-3

Licensed users, maximum allowed E-25

Lightweight I/O 20-14

LIMITNUMSESSIONS configuration parameter 1-85

Limits

- SQL statement cache size 1-152, 15-25
- virtual processors 15-20

Linking, name of root dbspace 1-122

Listen threads

- starting dynamically 15-23, 22-117
- stopping and restarting dynamically 15-23, 22-101
- stopping dynamically 15-23, 22-118

LISTEN_TIMEOUT configuration parameter 1-86

Listener thread 1-44

Location, extspace 20-16

Lock

- buffer-access-level flag bits 21-26
- information in syslocks table 2-22
- key-value 4-20
- maximum time to acquire 1-50
- monitoring with onstat -k 21-21, 21-192
- multiprocessor 1-100
- oncheck options 9-1
- type codes for onstat -k 21-192

Lock mode, page or row 1-51

LOCK_MODE tag 20-14

LOCKS configuration parameter 1-87

Log File Required event alarm 22-16

Log position 21-215, 21-217

log_full scripts 1-26, C-1

LOG_INDEX_BUILDS configuration parameter 1-89, 22-60

LOG_STAGING_DIR configuration parameter 1-90

LOGBUFF configuration parameter 1-87

LOGFILES configuration parameter 1-88

Logging

- blob space free-map page 4-23
- flags for mode 4-7

LOGGING tag 20-15

Logical character semantics 1-145

Logical log

- adding files 17-2
- backup
 - alarm triggered 1-26, C-1
 - dropping files 17-2
- file
 - created during initialization 1-88
 - displaying contents 14-1
 - log position 21-217
 - moving 17-2
 - reading the log file 14-1
 - size 1-91
 - switching with onmode 15-19
- files
 - maximum number 17-2
 - minimum number 17-2
- in root dbspace 4-1
- log position 21-215, 21-217
- maximum size 21-215
- monitoring with SMI 2-23

- Logical log (*continued*)
 - onparams
 - adding files 17-2
 - dropping files 17-2
 - record
 - additional columns 5-3
 - checkpoint 5-2
 - displaying 14-1
 - distributed transactions 5-2
 - DROP TABLE operation 5-1
 - generated by rollback 5-1
 - header columns 5-2
 - types 5-3, 5-14
 - specifying file size 17-2
- Logical page contents
 - displaying with oncheck 9-16
- Logical recovery, number of threads 1-107
- Logical-log buffer and LOGBUFF configuration parameter 1-87
- logmessage table E-1
- logposit field 21-217
- LOGSIZE configuration parameter 1-91
- LOGSMAX discontinued configuration parameter D-5
- Long transaction
 - high-water mark 1-94
 - LTXEHWM 1-93
 - LTXHWM 1-94
- Loosely-coupled mode 21-217
- LOW_MEMORY_MGR configuration parameter 1-91
- LOW_MEMORY_RESERVE configuration parameter 1-92
- LRU
 - changing dynamically 15-28
- LRU queues
 - displaying with onstat -R 21-22, 21-207
 - FLRU queues 21-207
 - MLRU queues 21-207
 - modified pages, percentage 1-36
- LRU_MAX_DIRTY discontinued configuration parameter D-6
- lru_max_dirty field in the BUFFERPOOL configuration parameter 1-36
- LRU_MIN_DIRTY discontinued configuration parameter D-6
- lru_min_dirty field in the BUFFERPOOL configuration parameter 1-36
- LRUS discontinued configuration parameter D-7
- lrus field in the BUFFERPOOL configuration parameter 1-36
- LTXEHWM configuration parameter 1-93
- LTXHWM configuration parameter 1-94

M

- MAX_FILL_DATA_PAGES configuration parameter 1-95
- MAX_INCOMPLETE_CONNECTIONS configuration parameter 1-96
- MAX_PDQPRIORITY configuration parameter
 - changing value 15-12
 - defined 1-96
- MaxConnect
 - DBSERVERALIASES configuration parameter 1-44
 - DBSERVERNAME configuration parameter 1-46
 - NETTYPE configuration parameter 1-101
- Maximum number
 - chunks 20-2
 - storage spaces 20-5, 20-7, 20-11, 20-16
- Maximum user connections E-25
- Memory
 - freeing unused segments 15-14
 - pools, SQL statement cache 1-153

- Memory (*continued*)
 - quantum allocated by MGM 21-116
 - specifying size of 1-109
- Memory Grant Manager
 - monitoring resources 21-116
- Memory information
 - SMI tables 2-25, 2-35
- Message authentication code files 1-73, 1-74
- Message log
 - alphabetical listing of messages E-1
 - categories of messages E-2
 - defined A-8, E-1
 - displaying with onstat -m 21-21, 21-197
 - event alarms C-3
 - finderr utility 7-1
 - location 1-100
 - viewing messages E-1
- Messages
 - A-B E-2, E-4
 - assertion-failed E-2
 - C E-4, E-14
 - changing sbspace minimum extent size 20-15
 - conversion and reversion E-49, E-61
 - D-E-F E-14, E-19
 - dynamic log E-65, E-67
 - Enterprise Replication E-61, E-65
 - G-H-I E-19, E-22
 - in-place ALTER TABLE E-18
 - J-K-L-M E-22, E-27
 - N-O-P E-27, E-36
 - onspaces E-33
 - Q-R-S E-36, E-41
 - sbspace metadata E-67, E-68
 - symbols E-48, E-49
 - T-U-V E-41, E-47
 - truncate table E-68
 - turning off smart-large-object logging 20-15
 - W-X-Y-Z E-47, E-48
- Metadata
 - area, structure 4-25
 - checking with oncheck 9-1
 - creating 20-11
 - messages E-67, E-68
 - size 20-11, 20-14
 - specifying offset 4-24, 20-11
 - specifying size 20-12
 - temporary sbspace 1-129
- MGM
 - information 2-24
- mi_lo_decrefcount() function 20-18
- mi_lo_increfcount() function 20-18
- mi_lo_specset_estbytes() function 20-15
- mi_lo_stat function() 20-18
- Microsoft Transaction Server
 - defined 21-215
 - onstat -x output 21-217
- MIN_EXT_SIZE tag 20-15
- Mirror chunk, structure 4-3
- MIRROR configuration parameter 1-98
- Mirroring
 - changing chunk status 20-27
 - enable flag 1-98
 - initial chunk 1-99
 - starting 20-22
 - stopping 20-24
- MIRROROFFSET configuration parameter 1-98
- MIRRORPATH configuration parameter 1-99

- Modes
 - encryption 1-71
- Modified pages
 - specifying percentage
 - LRU queue 17-4
- monitor server status
 - onstat utility 21-19
- Monitoring
 - display environment variables 21-86
 - distributed queries 21-215
 - licensed user connections E-25
 - MGM resources 21-116
- Moving logical-log files 17-2
- MSG_DATE configuration parameter 1-99
- MSGPATH configuration parameter 1-100
- Multiprocessor computer
 - AFF_SPROC configuration parameter D-2
 - processor affinity 1-167
- MULTIPROCESSOR configuration parameter 1-100
- Mutex threads 21-154
- MVIDXND logical-log record 5-3

N

- Name
 - blobspace 20-5
 - dbspace 20-7
 - extspace 20-16
 - sbspaces 20-11
- Name service cache 1-105
- NET_IO_TIMEOUT_ALARM 1-101
- NETTYPE configuration parameter
 - defined 1-101
- Network information
 - SMI tables 2-25, 2-26
- Newline character, quoted strings 1-27
- NEXT_SIZE tag 20-15
- Next-extent
 - allocation 4-10
 - allocation strategy 4-11
 - doubling of size 4-11
 - initial size 4-7
 - nonfragmented table 4-8
- no_log scripts 1-26
- NOAGE discontinued configuration parameter D-7
- Node, index
 - branch 4-16
 - creating 4-18
 - what points to 4-18
 - checking horizontal and vertical nodes 9-3, 9-11
 - defined 4-16
 - leaf 4-16
 - contents 4-18
 - pointer 4-18
 - root node 4-16
 - creating 4-17
 - when fills 4-18
 - types 4-16
- Non-default page size
 - physical log 17-4
- NS_CACHE configuration parameter 1-105
- NSF lock contention 1-106
- NUMAIOVPS configuration parameter
 - defined D-8
- Number of page-cleaner threads 1-41
- NUMCPUVPS configuration parameter
 - defined D-8

- NUMFDSERVERS configuration parameter 1-106

O

- OFF_RECVRY_THREADS configuration parameter 1-107
- Offset
 - mirrored chunk 20-11
 - size 20-2, 20-5, 20-7, 20-12, 20-16
- omode -wf or -wm
 - changing configuration parameters 15-26
 - usage 15-26
- ON_RECVRY_THREADS configuration parameter 1-107
- ON-Bar utility
 - activity log A-4
 - emergency boot files A-5
 - sm_versions file A-10
 - system tables 2-6
 - xbsa.messages log A-11
- ON-Monitor utility
 - Archive menu options 16-2
 - changing
 - database server mode 15-18
 - Dbspaces menu options 16-2
 - executing shell commands 16-2
 - Force-Ckpt menu options 16-2
 - help 16-1
 - Logical-Logs menu options 16-2
 - Mode menu options 16-2
 - navigating 16-1
 - Parameters menu options 16-2
 - Status menu options 16-2
 - using 16-1
- onbar argument 22-93
- oncfg file
 - and onspaces 20-1
 - defined A-9
- oncheck -pt command 22-99
- oncheck -pT command 22-99
- oncheck utility
 - check-and-repair 9-1
 - defined 9-1
 - display reserved, physical-log, and logical-log pages 4-2
 - list of functions 9-1
 - locking 9-3
 - oncheck utility
 - space required for sorting 9-1
 - option descriptions 9-3
 - options
 - cc 9-8
 - cd 9-8
 - cD 9-8
 - ce 9-3, 9-10
 - ci 9-11
 - cl 9-11
 - cr 9-12
 - cR 9-12
 - cs 9-13
 - cS 9-13
 - n 9-2, 9-3
 - pB 9-13
 - pc 9-8
 - pd 9-13
 - pD 9-13
 - pe 4-1, 9-10
 - pk 9-15
 - pK 9-15
 - pl 9-15

oncheck utility (*continued*)

- options (*continued*)
 - pL 9-15
 - pp 9-16
 - pP 9-16
 - pr 1-2, 4-2, 9-18
 - pR 4-2, 9-18
 - ps 9-13
 - pS 9-13
 - pt 9-19
 - pT 9-19
 - u 9-22
 - x 9-21
 - y 9-2, 9-3
- overview of functionality 9-1
- suppressing messages 9-3
- syntax 9-3

onclean utility 10-1

oncmsm utility

- managing high-availability servers 11-1

onconfig configuration file

- displaying 1-2
- format 1-1
- preparing 1-2
- templates 1-2

ONCONFIG configuration file

- defined A-9
- displaying 21-21, 21-28
- setting with genoncfg utility 8-1
- using onstat -c 21-28

ONCONFIG environment variable

- ONCONFIG file A-9

ONCONFIG parameters

- LOG_INDEX_BUILDS 22-60

onconfig.std template file

- defined 1-2
- printing 1-2

ondblog utility 12-1

- BAR_ACT_LOG file 12-1
- defined 12-1

ONDBSPACEDOWN configuration parameter 22-82

- defined 1-108
- overriding WAIT mode 15-20

oninit

- i option
 - affect of FULL_DISK_INIT 1-81
- return codes 13-4

oninit utility

- option descriptions 13-1
- options
 - i 13-1
 - j 13-1
 - s 13-1
- starting database server 13-1

ONLIDX_MAXMEM configuration parameter 1-109

onlog utility

- defined 14-1
- filters for logical-log records
 - displaying 14-1
 - reading 5-3, 14-1
- options
 - b 14-1
 - c 14-1
 - d 14-1
 - l 5-3, 14-1
 - n 14-1
 - q 14-1

onlog utility (*continued*)

- options (*continued*)
 - t 14-1
 - u 14-1
 - x 14-1
- onmode -c command 22-73
- onmode -D command 22-77
- onmode -e command 22-77
- onmode -F command 22-78
- onmode -j command 22-79
- onmode -l command 22-80
- onmode -m command 22-80
- onmode -M command 22-81
- onmode -n command 22-82
- onmode -O command 22-82
- onmode -p command 22-83
- onmode -Q command 22-84
- onmode -r command 22-85
- onmode -S command 22-86
- onmode -W command 22-86
- onmode -wf command 22-88, 22-109
- onmode -wm AUTO_LRU_TUNING command 22-90
- onmode -wm command 22-89, 22-108
- onmode -Y command 22-91
- onmode -z command 22-92
- onmode -Z command 22-93
- onmode and a arguments 22-72
- onmode and c arguments 22-73
- onmode and C arguments 22-74
- onmode and d arguments 22-75
- onmode and D arguments 22-77
- onmode and e arguments 22-77
- onmode and F arguments 22-78
- onmode and j arguments 22-79
- onmode and l arguments 22-80
- onmode and m arguments 22-80
- onmode and M arguments 22-81
- onmode and n arguments 22-82
- onmode and O arguments 22-82
- onmode and p arguments 22-83
- onmode and Q arguments 22-84
- onmode and r arguments 22-85
- onmode and S arguments 22-86
- onmode and W arguments 22-86
- onmode and wf arguments 22-88
- onmode and wm arguments 22-89
- onmode and Y arguments 22-91
- onmode and z arguments 22-92
- onmode and Z arguments 22-93
- onmode syntax 15-1
- onmode utility
 - P option 15-23
 - adding
 - shared-memory segment 15-2
 - virtual processors 15-20
 - administration mode 15-18
 - blocking the database server 15-4
 - caching the allowed.surrogates file 15-6
 - changing
 - database server mode 15-16, 15-18
 - DS_MAX_QUERIES 15-12
 - DS_MAX_SCANS 15-12
 - DS_TOTAL_MEMORY 15-12
 - MAX_PDQPRIORITY 15-12
 - shared-memory residency 15-19
 - SQL statement cache usage 15-14, 15-25
 - changing SQL statement cache 1-151

- onmode utility (*continued*)
 - defined 15-1
 - forcing a checkpoint 15-4
 - freeing memory segments 15-14
 - killing
 - distributed transactions 15-31
 - session 15-30
 - marking disabled dbspace as down 15-20
 - options
 - a 15-2
 - BC 1 15-3
 - BC 2 15-3
 - c block 15-4
 - c unblock 15-4
 - cache surrogates 15-6
 - d 15-8
 - D 15-12
 - e 1-151, 15-14
 - F 15-14
 - I 15-15
 - j 15-16
 - j -U 15-18
 - k 15-16, 15-17
 - l 15-19
 - m 15-16, 15-17
 - M 15-12
 - n 15-19
 - O 15-20
 - p 15-20
 - Q 15-12
 - r 15-19
 - R 15-24
 - s 15-16, 15-17
 - S 15-12
 - u 15-16, 15-17
 - W 15-25
 - Y 15-29
 - y confirm action 15-1
 - z 15-30
 - Z 15-31
 - PDQ 21-116
 - regenerating .infos file 15-24
 - removing virtual processors 15-20
 - rereading the allowed.surrogates file 15-6
 - setting
 - data replication type 15-8
 - decision-support parameters 15-12
 - Starting or ending forced residency 15-19
 - switching logical-log files 15-19
 - trapping errors 15-15, B-1
 - unblocking the database server 15-4
- onmode, wm, and AUTO_LRU_TUNING arguments 22-90
- onparams utility 17-1
 - adding logical-log file 17-2
 - backing up changes to physical log 17-4
 - changing physical log size and location 17-3
 - defined 17-1
 - dropping a logical-log file 17-2
 - examples 17-6
- onpassword utility
 - configuring secure connections 18-3
 - encrypting or decrypting text files 18-1
- onpload
 - onstat -j utility 21-190
- onshutdown script 10-2
- onmsync argument 22-95
- onsnmp log file A-10
- onsocimc protocol 1-101
- onspaces
 - syntax 20-1
- onspaces -f command 22-107
- onspaces -m command 22-118
- onspaces -r command 22-119
- onspaces -ren command 22-99
- onspaces utility
 - Df options 20-13
 - adding a chunk to
 - dbspace or blobspace 20-2
 - sbspaces 20-3
 - avoid chunk overwrite 20-28
 - changing chunk status 20-27
 - changing sbspace defaults 20-16, 20-17
 - cleaning up sbspaces 20-18
 - creating a blobspace 20-5
 - creating a temporary sbspace 20-11
 - creating an extspace 20-16
 - creating an sbspace 20-11
 - defined 20-1
 - dropping a blobspace, dbspace, extspace, or sbspace 20-20
 - dropping a chunk 20-19
 - ending mirroring 20-24
 - forcing a drop 20-20
 - options
 - a 20-2, 20-3
 - b 20-5
 - c 20-5, 20-7, 20-16
 - cl 20-18
 - d 20-19, 20-20
 - Df 20-12
 - f 20-21
 - g 20-5, 20-16
 - l 20-16
 - m 20-22
 - Mo 20-3, 20-11
 - Ms 20-3, 20-12
 - r 20-24
 - s 20-27
 - S 20-11
 - t 20-7, 20-10, 20-13
 - x 20-16
 - specifying DATASKIP 20-21
 - starting mirroring 20-22
- onsrvapd.log file A-10
- onstat -g options 21-42
- onstat utility
 - option 21-23
 - option 21-19, 21-24
 - a option 21-20, 21-25
 - b option 21-21, 21-25
 - B option 21-21, 21-24, 21-26
 - c option 21-21, 21-28
 - C option 21-21, 21-29
 - d option 1-47, 21-21, 21-34
 - D option 21-21, 21-39
 - d update option 21-34
 - f option 1-42, 21-21
 - F option 1-41, 21-21, 21-40
 - g afr option 21-48
 - g aqt option 21-49
 - g ath option 21-24
 - g cdr option 21-58
 - g ckp option 21-61
 - g cluster option 21-65
 - g con option 21-148

onstat utility (continued)

- g cpu option 21-71
- g dbc option 21-73
- g ddr option 21-74
- g defragment option 21-76
- g dic option 21-76
- g dis option 21-77
- g dll option 21-79
- g dmp option 21-80
- g dri ckpt option 21-81
- g dri option 21-81
- g dsc option 21-83
- g dsk option 21-79
- g dss command 21-84
- g dtc command 21-85
- g env option 21-86
- g ffr option 21-88
- g glo option 21-89
- g glo options A-8
- g grp command 21-91
- g his option 21-97
- g ioa option 21-102
- g iob option 21-103
- g iof option 21-104
- g iog option 21-105
- g ioq option 21-105
- g iov option 21-107
- g ipl option 21-107
- g lap option 21-109
- g laq option 21-109
- g lmx option 21-113
- g lsc option 21-114
- g mem option 21-115
- g mgm option 15-12, 21-116
- g nbm option 21-119
- g nif option 21-120
- g nsc option 1-101, 21-121
- g nsd option 21-124
- g nss option 21-125
- g ntd option 21-125
- g ntm option 21-126
- g ntt option 21-127
- g ntu option 21-127
- g opn option 21-127
- g option 21-21
- G option 21-21, 21-187
- g options 21-42
- g osi option 21-130
- g pos option 21-130
- g ppd option 21-131
- g ppf option 1-158, 21-132
- g pqs option 21-133
- g prc option 21-134
- g proxy option 21-135
- g qst option 21-141
- g que option 21-140
- g rbm option 21-144
- g rcv option 21-144
- g rea option 21-147
- g rep option 21-148
- g rss option 21-151
- g rwm option 21-154
- g sch option 21-155
- g scn option 21-155
- g sds option 21-157
- g seg option 1-135, 21-24, 21-161
- g ses option 21-162

onstat utility (continued)

- g sle option 21-167
- g smb option 21-167
- g smx option 21-169
- g spi option 21-171
- g sql option 21-172
- g src option 21-173
- g ssc all option 21-174
- g ssc option 1-152, 21-174
- g ssc pool option 1-153, 21-174
- g stk option 21-176
- g stm option 21-176
- g stq option 21-177
- g sts option 21-177
- g sym option 21-178
- g sync option 21-179
- g tpf option 21-180
- g ufr option 21-181
- g vpcache option 21-182
- g wai option 21-184
- g wmx option 21-185
- g wst option 21-185
- h option 21-21, 21-188
- i option 21-19, 21-21, 21-24, 21-189
- j option 21-190
- k option 1-87, 21-21, 21-192
- l option 1-87, 17-2, 21-21, 21-193
- L option 21-196
- m option 1-100, 21-21, 21-197, E-1
- o nobuff option 21-24
- o option 21-21, 21-24, 21-198
- O option 1-109, 21-21, 21-198
- options source_file 21-24
- p option 21-200
- P option 21-22, 21-24, 21-203
- pu option 21-19
- r option 21-19, 21-22, 21-204
- R option 21-22, 21-207
- s option 21-22, 21-209
- t option 21-22, 21-211
- T option 21-211
- u option 21-22, 21-212
- x option 15-31, 21-22, 21-215
- X option 21-22, 21-217
- z option 21-22, 21-219
- defined 21-1
- displaying
 - chunk information 21-34
 - ONCONFIG file 21-21
- freeing blobpages 21-34
- header 21-23
- monitor server status 21-19
- monitoring
 - PDQ 21-116
- no options 21-23
- onstat -g lmm 21-111
- onstat -g rah 21-142
- print file info about B-tree scanner subsystem and thread 21-29
- repeated execution
 - r option 21-22
 - seconds parameter 21-19
- return codes on exit 21-219
- syntax 21-19
- table of options 21-19
- terminating interactive mode 21-189
- terminating repeating sequence 21-189

- onstat utility (*continued*)
 - using SMI tables for onstat information 2-46
- ontape archive argument 22-96
- onliimc protocol 1-101
- OPCACHEMAX configuration parameter 1-109
- OPT_GOAL configuration parameter 1-110
- OPTCOMPIND
 - configuration parameter 1-110
 - environment variables 1-110
- Optical storage and STAGEBLOB configuration parameter 1-150
- Optical Subsystem memory cache 21-21, 21-198
- Optimizer directives 1-77
- Optimizing hash and nested-loop joins 1-110

P

Page

- bitmap page 4-23
- blobpage 4-23
- blobpage free-map page 4-23
- components of dbspace page 4-12
- compression 4-15
- dbspace blobpage 4-22
- dbspace page types 4-8, 4-9
- definition of full page 4-14
- free page, defined 4-8, 4-9
- page types in extent 4-8, 4-9
- reuse of index page 4-20
- size, shown with onstat -b 21-25
- structure and storage of 4-12
- Page compression 4-15
- Page header, length of 4-5
- Page zero 1-81
- PAGE_CONFIG reserved page 1-2, 4-2, 9-12
- Page-cleaner threads
 - codes for activity state 21-40
 - monitoring activity 21-21, 21-40
 - numbers 1-41
- Parallel database queries
 - gate information 21-116
 - MGM resources 21-116
 - monitoring resources 21-116
 - monitoring resources allocated 21-116
- partitions
 - defragmenting 22-42
- Partnum field in systables 4-5
- Passwords, encrypted, not shown in onstat -g sql 21-172
- Pathname, specifying 20-5, 20-7, 20-12
- PBDELETE logical-log record 5-3
- PBINSERT logical-log record 5-3
- PC_HASHSIZE configuration parameter 1-112
- PC_POOLSIZE configuration parameter 1-112
- PDELETE record subtype (SBLOB) 5-14
- PDINDEX logical-log record 5-3
- PDQ
 - CPU VPs 15-20
 - DS_MAX_QUERIES configuration parameter 1-61
 - DS_MAX_SCANS configuration parameter 1-62
 - DS_TOTAL_MEMORY configuration parameter 1-64 information 2-24
 - MAX_PDQPRIORITY configuration parameter 1-96
 - PDQPRIORITY configuration parameter 1-96
- PDQPRIORITY configuration parameter 1-96
- Pending transaction 21-215
- PERASE logical-log record 5-3
- Performance advisory messages 21-61

- PGALTER logical-log record 5-3
- PGMODE logical-log record 5-3
- ph_alert table 3-5
 - event alarms C-3
- ph_group table 3-5
- ph_run table 3-4
- ph_task table 3-2
- ph_threshold table 3-8
- PHYSBUFF configuration parameter 1-113
- PHYSDBS configuration parameter D-9
- PHYSFILE configuration parameter 1-114
- Physical log
 - backing up
 - changes 17-4
 - files 17-4
 - changing
 - size and location 17-3
 - changing size 17-3
 - root dbspace 4-1
 - size 1-114
 - using non-default page size 17-4
- Physical-log buffer
 - dbspace location D-9
 - size 1-113
- PLOG_OVERFLOW_PATH configuration parameter 1-114
- PN_STAGEBLOB_THRESHOLD configuration parameter 1-115
- PNGPALIGN8 log record 5-3
- PNLOCKID logical-log record 5-3
- PNSIZES logical-log record 5-3
- Pools
 - SQL statement cache 21-174
- PRELOAD_DLL_FILE configuration parameter 1-115
- PREPARE logical-log record 5-3
- Preventing long transactions 1-94
- Primary key, use in fragmented table 4-14
- print error argument 22-97
- print partition argument 22-99
- Printing
 - diagnostics, onmode -I B-1
 - global transactions 21-187
 - onconfig.std template file 1-2
- Priority aging, of CPU virtual processors D-7
- Private environment file A-6
- Processor affinity
 - AFF_NPROCS configuration parameter D-2
 - AFF_SPROC configuration parameter D-2
 - multiprocessors 1-100
 - set with VPCLASS configuration parameter 1-167
- Processor, locking for multiple or single 1-100
- Profile
 - displaying count, onstat -p 21-22, 21-200
 - monitoring with SMI 2-26, 2-27
 - setting counts to zero 21-22, 21-219
- Profile, partition 1-158
- PTADDESC logical-log record 5-3
- PTALTER logical-log record 5-3
- PTALTNEWKEYD log record 5-3
- PTALTOLDKEYD log record 5-3
- PTCOLUMN log record 5-3
- PTEXTEND logical-log record 5-3
- PTRENAME log record 5-3
- PTRUNC record subtype 5-14
- PTRUNCATE log record 5-3

Q

- QSTATS configuration parameter 1-116
 - with onstat-g qst 21-141
- Quantum, of memory 21-116
- Quiescent mode 15-16, 15-17

R

- RA_PAGES configuration parameter 1-116
- Raw disk space
 - UNIX 20-2
 - Windows 20-2, 20-5, 20-7
- RDELETE logical-log record 5-3
- Read-ahead, data pages
 - number 1-116
- Receive Manager in Enterprise Replication 21-144
- Recovery threads
 - offline 1-107
 - online 1-107
- REFCOUNT record subtype 5-14
- Reliable Queue Manager (RQM) in Enterprise Replication 21-148
- Remainder page, defined 4-14
- REMOTE_SERVER_CFG configuration parameter 1-117, 1-125
- REMOTE_USERS_CFG configuration parameter 1-118
- Removing
 - CPU virtual processors 15-22
 - stray smart large objects 20-18
 - virtual processors 15-20
- rename space argument 22-99
- RENDBS logical-log record 5-3
- REPEVT_CLUST_CHG
 - event class 2-32
 - sub-events 2-32
- REPEVT_CLUST_LATSTAT
 - event class 2-32
 - sub-events 2-32
- REPEVT_CLUST_PERFSTAT
 - event class 2-32
 - sub-events 2-32
- REPEVT_CM_ADM
 - event class 2-32
 - sub-events 2-32
- REPEVT_ER_ADM
 - event class 2-32
 - sub-events 2-32
- REPEVT_SRV_ADM
 - event class 2-32
 - sub-events 2-32
- Reserved area, sbspace 4-24
- Reserved pages
 - checking with oncheck 9-3, 9-12
 - defined 4-2
 - location in root dbspace 4-1
 - viewing contents 4-2
- reset sysadmin argument 22-100
- RESIDENT configuration parameter
 - defined 1-119
- Resident shared memory
 - Configuration parameters
 - RESIDENT 15-19
 - RESIDENT configuration parameter 1-119
 - onmode -r or -n 15-19
 - turning on and off residency 15-19
- restart listen argument 22-101
- RESTARTABLE_RESTORE configuration parameter 1-120

- RESTORE_POINT_DIR configuration parameter 1-121
- Results tables 3-8
- Return codes
 - onstat utility, on exit 21-219
- Reuse of freed index pages 4-20
- revcdr.out file E-61
- revcdr.sh script A-1, A-10, E-61
- Reversion messages
 - database server E-49, E-61
 - Enterprise Replication E-61, E-65
- REVERT logical-log record 5-3
- revtestcdr.out file E-61
- rhosts 1-118
- RINSERT logical-log record 5-3
- ROLLBACK logical-log record 5-3
- Rolling back long transactions 1-93
- ROLWORK logical-log record 5-3
- Root dbspace
 - initial chunk 1-122
 - mirroring 1-99
 - specifying ROOTNAME configuration parameter 1-122
 - structure 4-1
 - using a link 1-122
- ROOTNAME configuration parameter
 - defined 1-122
 - use by PHYSDBS D-9
- ROOTOFFSET configuration parameter 1-122
- ROOTPATH configuration parameter
 - defined 1-122
 - specifying as a link 1-99, 1-122
- ROOTSIZE configuration parameter 1-123
- Round-robin fragmentation
 - constraints 1-115
- ROWID
 - defined 4-13
 - fragmented table 4-13
 - functions as forward pointer 4-13
 - locking information 21-192
 - stored in index pages 4-13
- Rows
 - data, storage 4-14
 - displaying contents with oncheck 9-13
 - storage location 4-14
- RSS_FLOW_CONTROL configuration parameter 1-123
- RSVEXTEN logical-log record 5-3
- RTO_SERVER_RESTART configuration parameter 1-125
- RTREE logical-log record 5-3

S

- S6_USE_REMOTE_SERVER_CFG configuration parameter 1-125
- SB_CHECK_FOR_TEMP configuration parameter 1-126
- SBLOB logical-log record 5-14
- Sbpage structure 4-26
- SBSPACENAME configuration parameter 1-127, 1-157
- sbspaces
 - g option 20-16
 - adding a chunk 20-3
 - changing defaults 20-16, 20-17
 - cleaning up references 20-18
 - creating with onspaces 20-11
 - default name 1-127
 - dropping a chunk 20-19
 - dropping a sbspace 20-20
 - ending mirroring 20-24
 - maximum number 20-5, 20-7, 20-11, 20-16

- sbspaces (*continued*)
 - metadata area
 - size and offset 20-11, 20-14
 - structure 4-25
 - multiple chunk 4-26
 - naming conventions 20-11
 - onstat -d usage 21-34
 - reserved area 4-24
 - sbpage structure 4-26
 - starting mirroring 20-22
 - structure 4-24
 - temporary 1-129, 20-13, 21-34
 - creating 20-12, 20-13
 - user-defined data statistics 1-157
- SBSPACETEMP configuration parameter 1-129, 20-13
- Schedule Manager for Enterprise Replication 21-148
- Scheduler
 - relationship between tables 3-1
 - sensor historical data results tables 3-8
- scheduler argument 22-102
- Scheduler group names
 - ph_group table 3-5
- scheduler lmm disable argument 22-105
- scheduler lmm enable argument 22-102
- Scheduler messages
 - ph_alert table 3-5
- Scheduler task information
 - ph_run table 3-4
 - ph_task table 3-2
- Scheduler task thresholds
 - ph_threshold table 3-8
- Screen reader
 - reading syntax diagrams G-1
- Scripts
 - concdr.sh A-5
 - ex_alarm.sh 1-26, C-1
 - log_full 1-26, C-1
 - no_log 1-26
 - onshutdown 10-2
 - revcdr.sh A-10
- SDS_ENABLE configuration parameter 1-129
- SDS_LOGCHECK configuration parameter 1-130
- SDS_PAGING configuration parameter 1-131
- SDS_TEMPDBS configuration parameter 1-131
- SDS_TIMEOUT configuration parameter 1-133
- security
 - local 1-133
- SECURITY_LOCALCONNECTION configuration parameter 1-133
- SEQ_CACHE_SIZE configuration parameter 1-134
- Server shut down
 - troubleshooting event alarms C-53
- SERVERTNUM configuration parameter 1-134
- Session information
 - global transactions 21-217
 - SMI tables 2-31, 2-36
- Sessions
 - limiting 1-85
- set chunk argument 22-106
- set dataskip argument 22-107
- SET EXPLAIN statement
 - setting dynamically 15-29
- set index compression argument 22-107
- set onconfig memory argument 22-108
- set onconfig permanent argument 22-109
- set sbspace accesstime argument 22-110
- set sbspace avg_lo_size argument 22-111
- set sbspace logging argument 22-112
- set sql tracing argument 22-112
- set sql tracing database argument 22-114
- set sql tracing session argument 22-115
- set sql tracing user argument 22-116
- set sql user tracing argument 22-116
- SET STATEMENT CACHE statement 1-151, 15-14
- Setting data replication type 15-8
- severity 5 alarms
 - troubleshooting C-53
- Shared library files A-6
- Shared memory
 - adding segment with onmode 15-2
 - base address 1-136
 - buffer, frequency of flushing 1-36
 - buffer, maximum number 1-36
 - changing
 - decision-support parameters 15-12
 - residency with onmode 15-19
 - decision-support parameters 22-77
 - dumps 1-67, 1-68
 - examining with SMI 2-2
 - initializing 13-1
 - monitoring 21-1
 - physical-log buffer 1-113
 - resident portion, flag 1-119
 - saving copy of with onstat 21-21
 - segments, dynamically added, size 1-135
 - SERVERTNUM configuration parameter 1-134
 - size displayed by onstat 21-23
 - virtual segment, initial size 1-139
- shared memory dump file
 - using onstat commands 21-24
- SHMADD configuration parameter 22-72
 - 64-bit addressing 1-135
 - defined 1-135
- SHMBASE configuration parameter 1-136
- shmem file
 - DUMPSHMEM configuration parameter 1-68
 - shmem.xxx A-10
- SHMNOACCESS configuration parameter 1-136
- SHMTOTAL configuration parameter 1-137
- SHMVIRT_ALLOCSEG configuration parameter 1-138
- SHMVIRT_SIZE configuration parameter 1-139
- Shortcut keys
 - keyboard G-1
- Shutting down the database server 10-1, 10-2, 15-16, 15-17
- SINGLE_CPU_VP configuration parameter 1-141
- Size
 - chunk 20-2, 20-3
 - index fragments 4-8
 - metadata 20-12
 - offset 20-5, 20-7, 20-12, 20-16
- sm_versions.std file A-10
- Smart large objects 1-157
 - buffer pool 1-36
 - cleaning up references 20-18
 - default name 1-127
 - logging 20-15
 - logical-log records 5-14
- SMX
 - compression 1-142
- SMX_COMPRESS configuration parameter 1-142
- Snapshot
 - clone a snapshot of a database server 19-1
- snmpd.log file A-10
- SP_AUTOEXPAND configuration parameter 1-143

SP_THRESHOLD configuration parameter 1-143
 SP_WAITTIME configuration parameter 1-144
 Specify
 modified pages, percentage
 LRU queue 17-4
 Specifying pathname 20-2
 SQL administration API
 admin() functions 22-1
 remote administration 22-1
 task() functions 22-1
 SQL administration API functions
 add bufferpool argument 22-13
 add chunk argument 22-14
 add log argument 22-16
 add memory argument 22-17
 add mirror argument 22-18
 admin() 22-1
 argument size 22-2
 return codes 22-2
 syntax rules 22-1
 alter chunk argument 22-19
 alter logmode argument 12-1, 22-20
 alter plog argument 22-21
 archive fake argument 22-21
 arguments by functional category 22-4
 cdr argument 22-22
 check data argument 22-23
 check extents argument 22-24
 check partition argument 22-24
 checkpoint argument 22-25
 clean sbspace argument 22-26
 compress argument 22-127
 compression purge_dictionary argument 22-133
 create blobspace argument 22-26
 create blobspace from storagepool argument 22-28
 create chunk argument 22-29
 create chunk from storagepool argument 22-30
 create database argument 22-31
 create dbspace argument 22-32
 create dbspace from storagepool argument 22-33
 create sbspace argument 22-34
 create sbspace from storagepool argument 22-35
 create sbspace with accesstime argument 22-36
 create sbspace with log argument 22-37
 create tempdbspace argument 22-38
 create tempdbspace from storagepool argument 22-39
 create tempsbspace argument 22-40
 create tempsbspace from storagepool argument 22-41
 create_dictionary argument 22-127
 drop blobspace argument 22-43
 drop blobspace to storagepool argument 22-44
 drop chunk argument 22-44
 drop chunk to storagepool argument 22-46
 drop database argument 22-46
 drop dbspace argument 22-47
 drop dbspace to storagepool argument 22-47
 drop log argument 22-48
 drop sbspace argument 22-49
 drop sbspace to storagepool argument 22-49
 drop tempdbspace argument 22-50
 drop tempdbspace to storagepool argument 22-51
 drop tempsbspace to storagepool argument 22-51
 estimate_compression argument 22-127
 command output 22-132
 file status 22-52
 for compressing data 22-126, 22-127
 fragment argument 22-127
 SQL administration API functions (*continued*)
 ha make primary argument 22-53
 ha rss add argument 22-55
 ha rss argument 22-54
 ha rss change argument 22-56
 ha rss delete argument 22-57
 ha sds clear argument 22-57
 ha sds primary argument 22-58
 ha sds set argument 22-59
 ha set idxauto argument 22-60
 ha set ipl argument 22-60
 ha set primary argument 22-61
 ha set secondary argument 22-62
 ha set standard argument 22-62
 ha set timeout argument 22-63
 message log delete 22-64
 message log rotate 22-65
 message log truncate 22-65
 modify chunk extend argument 22-66
 modify chunk extendable argument 22-67
 modify chunk extendable off argument 22-68
 modify space expand argument 22-69
 modify space sp_sizes argument 22-70
 onbar argument 22-93
 onmode and a arguments 22-72
 onmode and c arguments 22-73
 onmode and C arguments 22-74
 onmode and d arguments 22-75
 onmode and D arguments 22-77
 onmode and e arguments 22-77
 onmode and F arguments 22-78
 onmode and j arguments 22-79
 onmode and l arguments 22-80
 onmode and m arguments 22-80
 onmode and M arguments 22-81
 onmode and n arguments 22-82
 onmode and O arguments 22-82
 onmode and p arguments 22-83
 onmode and Q arguments 22-84
 onmode and r arguments 22-85
 onmode and S arguments 22-86
 onmode and W arguments 22-86
 onmode and wf arguments 22-88
 onmode and wm arguments 22-89
 onmode and Y arguments 22-91
 onmode and z arguments 22-92
 onmode and Z arguments 22-93
 onmode, wm, and AUTO_LRU_TUNING
 arguments 22-90
 onsmsync argument 22-95
 ontape archive argument 22-96
 print error argument 22-97
 print file info argument 22-98
 print partition argument 22-99
 rename space argument 22-99
 repack argument 22-127
 repack_offline argument 22-127
 reset sysadmin 22-100
 restart listen argument 22-101
 scheduler 22-102
 scheduler lmm enable 22-102, 22-105
 set chunk argument 22-106
 set dataskip argument 22-107
 set index compression argument 22-107
 set onconfig memory argument 22-108
 set onconfig permanent argument 22-109
 set sbspace accesstime argument 22-110

- SQL administration API functions *(continued)*
 - set sbspace avg_lo_size argument 22-111
 - set sbspace logging argument 22-112
 - set sql tracing argument 22-112
 - set sql tracing database argument 22-114
 - set sql tracing session argument 22-115
 - set sql tracing user argument 22-116
 - set sql user tracing argument 22-116
 - shrink argument 22-127
 - start listen argument 22-117
 - start mirroring argument 22-118
 - stop listen argument 22-118
 - stop mirroring argument 22-119
 - storagepool add argument 22-120
 - storagepool delete argument 22-122
 - storagepool modify argument 22-123
 - storagepool purge argument 22-125
 - table argument 22-127
 - task() 22-1
 - argument size 22-2
 - return codes 22-2
 - syntax rules 22-1
 - uncompress argument 22-127
 - uncompress_offline argument 22-127
- SQL profile
 - information 2-41
- SQL statement cache
 - enabling 1-151
 - enabling the cache 15-14
 - flushing the cache 15-14
 - inserting
 - key-only entries 1-152, 15-25
 - qualified statements 1-152, 15-25
 - limiting the cache size 1-152
 - memory pools 1-153
 - specifying number of hits 1-152, 15-25
 - turning off the cache 15-14
 - turning on the cache 1-151, 15-14
- SQL statements
 - SET STATEMENT CACHE 1-151, 15-14
 - UPDATE STATISTICS 1-157
- SQL_LOGICAL_CHAR configuration parameter 1-145
- SQLCA, warning flag when fragment skipped during query 1-42
- sqlhosts file or registry
 - defined A-10
 - multiple dbservernames 1-44
- sqlmux, multiplexed connections in NETTYPE configuration parameter 1-101
- SQLTRACE configuration parameter 1-147
- SSL_KEYSTORE_LABEL configuration parameter 1-148
- STACKSIZE configuration parameter 1-149
- STAGEBLOB configuration parameter 1-150
- standards xxxv
- start listen argument 22-117
- start mirroring argument 22-118
- Starting database server with oninit 13-1
- Starting the database server online 15-16, 15-17
- STATCHANGE configuration parameter 1-150
- STMT_CACHE configuration parameter 1-151
- STMT_CACHE environment variable 15-14
- STMT_CACHE environment variables 1-151
- STMT_CACHE_HITS configuration parameter 1-152, 15-25
- STMT_CACHE_NOLIMIT configuration parameter 1-152
- STMT_CACHE_NUMPOOL configuration parameter 1-153
- STMT_CACHE_SIZE configuration parameter 1-153
- stop listen argument 22-118
- stop mirroring argument 22-119
- STOP_APPLY configuration parameter 1-154
- Storage pool
 - adding an entry 22-120
 - create a blobspace from 22-28
 - create a chunk from 22-30
 - create a dbspace from 22-33
 - create a temporary dbspace from 22-39
 - create a temporary sbspace from 22-41
 - create an sbspace from 22-35
 - deleting an entry 22-122
 - modifying an entry 22-123
 - return space to 22-44, 22-46, 22-47, 22-49, 22-51
- STORAGE_FULL_ALARM configuration parameter 1-155
- storagepool table 3-9
- Symbolic links
 - using with shared libraries A-6
- Syntax diagrams
 - reading in a screen reader G-1
- sysadmin database 3-1, 22-1
 - Results tables 3-8
 - storagepool table 3-9
 - tables
 - command_history 3-8
 - ph_alert 3-5
 - ph_group 3-5
 - ph_run 3-4
 - ph_task 3-2
 - ph_threshold 3-8
- sysadinfo table 2-7
- SYSALARMPROGRAM configuration parameter 1-156
- sysaudit table 2-7
- syscheckpoint table 2-8
- syschkio table 2-8
- syschunks table 2-9
- sysckptinfo table 2-11
- syscluster table 2-11
- syscsm table 2-12
- syscsmmsla table 2-13
- syscsmstab table 2-13
- syscompdicts view 2-13
- syscompdicts_full table 2-13
- sysconfig table 2-15
- sysdatabases table 2-15
- sysdbslocale table 2-16
- sysdbspaces table 2-16
- sysdri table 2-17
- sysdual table 2-18
- sysenv table 2-18
- sysenvses table 2-18
- sysessions table 2-36
- sysextents table 2-18
- sysextspaces table 2-19
- sysfeatures 2-19
- sysfragdist system catalog table 1-157
- syssha_lagtime table 2-20
- syssha_type table 2-21
- syssha_workload table 2-21
- sysipl table 2-22
- syslocks table 2-22
- syslogfil table 2-24
- syslogs table 2-23
- sysmaster database
 - defined 2-1
 - failure to build A-5
 - functionality of 2-1
 - initialization 13-1

- sysmaster database *(continued)*
 - list of topics covered by 2-2
 - SMI tables 2-2
 - space required to build 2-1
 - sysextspaces 2-19
 - types of tables 2-1
 - warning 2-1
 - when created 2-1
- sysmaster tables
 - syssexplain 2-38
- sysmgminfo table 2-24
- sysnetclienttype table 2-25
- sysnetglobal table 2-25
- sysnetworkio table 2-26
- sysonlinelog table 2-26
- sysprofile table 2-27
- sysproxyagents table 2-28
- sysproxydistributors table 2-29
- sysproxysessions table 2-29
- sysproxytxnops table 2-30
- sysproxytxns table 2-30
- sysptprof table 2-31
- sysrepevtreg table 2-32
- sysrepstats table 2-32
- sysrsslog table 2-35
- SYSSBSPACENAME configuration parameter 1-157
- sysscblst table 2-35
- syssexpinfo table 2-35
- syssexpinfo table 2-36
- sysssmx table 2-38
- sysssmxses table 2-38
- syssexplain
 - sysmaster table 2-38
- syssqltrace table 2-39
- syssqltrace_info table 2-41
- syssqltrace_iter table 2-41
- syssrcrss table 2-41
- syssrcsds table 2-42
- systabnames table 2-42
- System catalog tables
 - disk space allocation 4-27
 - listing 9-3
 - oncheck -cc 9-8
 - oncheck -pc 9-8
 - sysdistrib 1-157
 - sysfragdist 1-157
 - sysfragments table 4-5
 - systracees B-1
 - systracemsgs B-1
 - tracking 4-27
 - tracking a new database 4-27
 - tracking a new table 4-28
- system page size, specifying 1-36
- System-monitoring interface
 - accessing SMI tables 2-3
 - defined 2-1
 - list of SMI tables 2-4
 - locking 2-4
 - obtaining onstat information 2-46
 - SPL 2-4
 - systabpghdrs table 2-3
 - tables
 - defined 2-2
 - list of supported 2-4
 - sysadinfo 2-7
 - sysaudit 2-7
 - syscheckpoint 2-8

- System-monitoring interface *(continued)*
 - tables *(continued)*
 - syschkio 2-8
 - syschunks 2-9
 - sysckptinfo 2-11
 - syscluster 2-11
 - syscompdicts 2-13
 - syscompdicts_full 2-13
 - sysconfig 2-15
 - sysdatabases 2-15
 - sysdblocale 2-16
 - sysdbspaces 2-16
 - sysdri 2-17
 - sysdual 2-18
 - sysenv 2-18
 - sysenvses 2-18
 - sysextents 2-18
 - sysextspaces 2-19
 - sysfeatures 2-19
 - syssha_lagtime 2-20
 - syssha_type 2-21
 - syssha_workload 2-21
 - sysipl 2-22
 - syslocks 2-22
 - syslogfil 2-24
 - syslogs 2-23
 - sysmgminfo 2-24
 - sysnetclienttype 2-25
 - sysnetglobal 2-25
 - sysnetworkio 2-26
 - sysonlinelog 2-26
 - sysprofile 2-27
 - sysproxyagents 2-28
 - sysproxydistributors 2-29
 - sysproxysessions 2-29
 - sysproxytxnops 2-30
 - sysproxytxns 2-30
 - sysptprof 2-31
 - sysrepevtreg 2-32
 - sysrepstats 2-32
 - sysrsslog 2-35
 - sysscblst 2-35
 - syssexpinfo 2-35
 - syssexpinfo 2-36
 - syssexpinfo 2-36
 - syssexpinfo 2-36
 - sysssmx 2-38
 - sysssmxses 2-38
 - syssqltrace 2-39
 - syssqltrace_info 2-41
 - syssqltrace_iter 2-41
 - syssrcrss 2-41
 - syssrcsds 2-42
 - systabnames 2-42
 - systhreads 2-43
 - systrgrss 2-43
 - systrgsds 2-44
 - sysvpprof 2-44
 - triggers 2-3
 - using SELECT statements 2-3
 - viewing tables with dbaccess 2-3
 - views 2-3, 2-4
- systhreads table 2-43
- systracees table B-1
- systracemsgs table B-1
- systrgrss table 2-43
- systrgsds table 2-44
- sysutil tables 2-6

sysvpprof table 2-44

T

Table

- creating, what happens on disk 4-27, 4-28
- displaying allocation information 9-19
- extent size doubling 4-11
- lock mode 1-51
- monitoring with SMI 2-42
- pseudotables 2-2
- SMI tables 2-2
- temporary
 - effects of creating 4-28
 - message reporting cleanup E-16

tables

- defragmenting 22-42
- sysrepevtreg 2-32
- sysrepstats 2-32

tail -f command E-1

task() functions 22-1

- add bufferpool argument 22-13
- add chunk argument 22-14
- add log argument 22-16
- add memory argument 22-17
- add mirror argument 22-18
- alter chunk argument 22-19
- alter logmode argument 12-1, 22-20
- alter plog argument 22-21
- archive fake argument 22-21
- argument size 22-2
- arguments by functional category 22-4
- cdr argument 22-22
- check data argument 22-23
- check extents argument 22-24
- check partition argument 22-24
- checkpoint argument 22-25
- clean sbspace argument 22-26
- compress argument 22-127
- compression purge_dictionary argument 22-133
- create blobspace argument 22-26
- create blobspace from storagepool argument 22-28
- create chunk argument 22-29
- create chunk from storagepool argument 22-30
- create database argument 22-31
- create dbspace argument 22-32
- create dbspace from storagepool argument 22-33
- create sbspace argument 22-34
- create sbspace from storagepool argument 22-35
- create sbspace with accesstime argument 22-36
- create sbspace with log argument 22-37
- create tempdbspace argument 22-38
- create tempdbspace from storagepool argument 22-39
- create tempdbspace argument 22-40
- create tempdbspace from storagepool argument 22-41
- create_dictionary argument 22-127
- drop blobspace argument 22-43
- drop blobspace to storagepool argument 22-44
- drop chunk argument 22-44
- drop chunk to storagepool argument 22-46
- drop database argument 22-46
- drop dbspace argument 22-47
- drop dbspace to storagepool argument 22-47
- drop log argument 22-48
- drop sbspace argument 22-49
- drop sbspace to storagepool argument 22-49
- drop tempdbspace argument 22-50

task() functions (continued)

- drop tempdbspace to storagepool argument 22-51
- drop tempdbspace to storagepool argument 22-51
- estimate_compression argument 22-127
 - command output 22-132
- file status 22-52
- for compressing data 22-126, 22-127
- fragment argument 22-127
- ha make primary argument 22-53
- ha rss add argument 22-55
- ha rss argument 22-54
- ha rss change argument 22-56
- ha rss delete argument 22-57
- ha sds clear argument 22-57
- ha sds primary argument 22-58
- ha sds set argument 22-59
- ha set idxauto argument 22-60
- ha set ipl argument 22-60
- ha set primary argument 22-61
- ha set secondary argument 22-62
- ha set standard argument 22-62
- ha set timeout argument 22-63
- message log delete 22-64
- message log rotate 22-65
- message log truncate 22-65
- modify chunk extend argument 22-66
- modify chunk extendable argument 22-67
- modify chunk extendable off argument 22-68
- modify space expand argument 22-69
- modify space sp_sizes argument 22-70
- onbar argument 22-93
- onmode and a arguments 22-72
- onmode and c arguments 22-73
- onmode and C arguments 22-74
- onmode and d arguments 22-75
- onmode and D arguments 22-77
- onmode and e arguments 22-77
- onmode and F arguments 22-78
- onmode and j arguments 22-79
- onmode and l arguments 22-80
- onmode and m arguments 22-80
- onmode and M arguments 22-81
- onmode and n arguments 22-82
- onmode and O arguments 22-82
- onmode and p arguments 22-83
- onmode and Q arguments 22-84
- onmode and r arguments 22-85
- onmode and S arguments 22-86
- onmode and W arguments 22-86
- onmode and wf arguments 22-88
- onmode and wm arguments 22-89
- onmode and Y arguments 22-91
- onmode and z arguments 22-92
- onmode and Z arguments 22-93
- onmode, wm, and AUTO_LRU_TUNING arguments 22-90
- onsmsync argument 22-95
- ontape archive argument 22-96
- print error argument 22-97
- print file info argument 22-98
- print partition argument 22-99
- rename space argument 22-99
- repack argument 22-127
- repack_offline argument 22-127
- reset sysadmin argument 22-100
- restart listen argument 22-101
- return codes 22-2

task() functions (*continued*)

- scheduler argument 22-102
- scheduler lmm disable argument 22-105
- scheduler lmm enable argument 22-102
- set chunk argument 22-106
- set dataskip argument 22-107
- set index compression argument 22-107
- set onconfig memory argument 22-108
- set onconfig permanent argument 22-109
- set sbspace accesstime argument 22-110
- set sbspace avg_lo_size argument 22-111
- set sbspace logging argument 22-112
- set sql tracing argument 22-112
- set sql tracing database argument 22-114
- set sql tracing session argument 22-115
- set sql tracing user argument 22-116
- set sql user tracing argument 22-116
- shrink argument 22-127
- start listen argument 22-117
- start mirroring argument 22-118
- stop listen argument 22-118
- stop mirroring argument 22-119
- storagepool add argument 22-120
- storagepool delete argument 22-122
- storagepool modify argument 22-123
- storagepool purge argument 22-125
- syntax rules 22-1
- table argument 22-127
- uncompress argument 22-127
- uncompress_offline argument 22-127

Tbospace

- displaying (onstat -t or -T) 21-22, 21-211
- monitoring
 - blspace statistics 1-158
 - with SMI 2-31
- number 4-5, 21-211
- table fragment 4-5, 4-15

Tbospace number

- defined 4-5
- includes dbspace number 4-5
- table fragment 4-5

Tbospace tbospace

- bitmap page 4-5
- location in a chunk 4-2
- location in root dbspace 4-1
- tracking new tables 4-28

TBLSPACE_STATS configuration parameter 1-158

- with onstat -g ppf 21-132

TBLTBLFIRST configuration parameter 1-159

TBLTBLNEXT configuration parameter 1-159

Template

- ac_config.std file A-4
- onconfig.std file A-8

Temporary dbspace

- creating with onspaces 20-7, 20-10
- DBSPACETEMP configuration parameter 20-10

Temporary sbspace

- creating with onspaces 20-12, 20-13
- onstat -d 21-34
- SBSPACETEMP configuration parameter 1-129

temporary sbspaces

- creating with onspaces 20-11

Temporary smart large object

- default sbspace 1-129
- SBSPACETEMP configuration parameter 1-129

Temporary tables

- DBSPACETEMP configuration parameter 1-47

Temporary tables (*continued*)

- extent size doubling 4-11
- rules for use 1-47

TEMPTAB_NOLOG configuration parameter 1-160

TEXT and BYTE data

- blob descriptor 4-12, 4-22
- modifying storage 4-22
- page descriptor 4-22
- size limitations 4-23
- storage on disk 4-21, 4-22
- updating 4-22
- when modified 4-22
- when written 4-22

thread

- status 21-185
- wait statistics 21-185

Threads

- Buffers
 - page-type codes 21-217
 - onstat -X usage 21-22, 21-217
- Tightly-coupled mode 21-217

Time stamp

- blobspace blobpage 4-23
- defined 4-27

Time-out condition 21-40

Trace B-1

Trace message B-1

Tracepoints B-1

Transaction manager

- loosely-coupled mode 21-217
- tightly-coupled mode 21-217

Transaction Replicate Group E-62

Transaction survival 1-79

Transaction-logging database property 2-15

Transactions

- heterogeneous commit 1-83
- kill with onmode -Z 15-31
- pending 21-215
- XID 21-217

Trapping errors with onmode B-1

Troubleshooting

- severity 5 event alarms C-53

TRUNCATE 5-3

TRUNCATE log record 5-3

Truncate table messages E-68

trusted hosts 1-117

trusted users 1-118

Tuning

- large number of users 1-101
- use of NETTYPE configuration parameter 1-101

Tuning recommendations 21-61

Turning on SQL statement cache 15-14

Two-phase commit protocol, killing distributed transactions 15-31

TXTIMEOUT configuration parameter

- defined 1-161
- onmode utility 15-31

U

UDINSERT

- record subtype 5-14

UDUPAFT

- record subtype 5-14

UDUPBEF

- record subtype 5-14

- UDWRITE
 - record subtype 5-14
- Unblocking database server 15-4
- Unbuffered disk space
 - UNIX 20-2
 - Windows 20-2, 20-5, 20-7
- Unbuffered-logging database property 2-15
- UNIX
 - buffered disk space 20-2
 - interrupt signal 6-1
 - unbuffered disk space 20-2
 - using onspaces 20-1
- UNSECURE_ONSTAT configuration parameter 1-161
- UPDATABLE_SECONDARY configuration parameter 1-162
- UPDATE STATISTICS statement 1-60, 1-64, 1-157
- Updating blob space statistics 21-34
- USELASTCOMMITTED configuration parameter 1-163
- USEOSTIME parameter 1-164
- User connections, monitoring E-25
- User session
 - monitoring with SMI 2-36
 - status codes 21-212
- user-defined data statistics 1-157
- User-defined routines, debugging B-1
- User-defined type
 - data distributions 1-157
- USERMAPPING configuration parameter 1-165
- USTLOW_SAMPLE configuration parameter 1-166
- Utilities 6-1
 - V option 6-1
 - version option 6-1
 - finderr 7-1
 - gcore 1-66
 - genoncfg 8-1
 - IBM Informix Server Administrator 6-2
 - ifxclone 19-1
 - ON-Monitor utility 16-1
 - oncheck 9-1, 9-22
 - onclean 10-1
 - oncmsm 11-1
 - ondblog utility 12-1
 - oninit 13-1
 - onlog 14-1
 - onmode 15-1, 15-29
 - onmode and PDQ 21-116
 - onparams 17-1, 17-6
 - onpassword 18-1, 18-3
 - onspaces 20-1, 20-21
 - onstat utility 21-1, 21-219
 - g env option 21-86
 - g mgm option 21-116
 - g seg option 1-135
 - option 6-1

V

- VARCHAR data type
 - 4-bit bit map requirement 4-8, 4-9
 - implications for data row storage 4-14
 - indexing considerations 4-20
 - storage considerations 4-12
- Violations table
 - messages E-4, E-44
- Virtual processors
 - adding or removing with onmode 15-20
 - designating a class 1-167
 - limits 15-20

- Virtual processors (*continued*)
 - number in
 - AIO class D-8
 - CPU class D-8
 - priority aging D-7
 - processor affinity 1-100
- Visual disabilities
 - reading syntax diagrams G-1
- VP configuration parameter
 - AFF_NPROCS D-2
- VP_MEMORY_CACHE_KB configuration parameter
 - defined 1-166
- VPservername.nnx file A-11
- VPCLASS configuration parameter
 - AFF_SPROC D-2
 - default values 1-167
 - defined 1-167
 - in ONCONFIG file 1-167
 - NOAGE D-7
 - NUMAIOVPS D-8
 - onmode utility 15-20
 - reserved names 1-167
 - setting maximum virtual processors 1-167
 - setting number of virtual processors 1-167
 - setting processor affinity 1-167
 - user-defined classes 1-167

W

- Warnings
 - buildsmi script 2-2
 - when fragment skipped during query processing 1-42
- Windows
 - adding or removing virtual processors 15-22
 - buffered disk space 20-2
 - unbuffered disk space 20-2, 20-5, 20-7
 - using onspaces 20-1
- WSTATS configuration parameter 1-170

X

- xbsa.messages log A-11



Printed in USA

SC27-3530-04



Spine information:

Informix Product Family Informix **Version 11.70**

IBM Informix Administrator's Reference

